

## Technical Manual

### AVT GigE Vision Cameras

V2.0.5

26 November 2013

## Legal notice

### For customers in the U.S.A.

This equipment has been tested and found to comply with the limits for a Class A digital device, pursuant to Part 15 of the FCC Rules. These limits are designed to provide reasonable protection against harmful interference when the equipment is operated in a residential environment. This equipment generates, uses, and can radiate radio frequency energy and, if not installed and used in accordance with the instruction manual, may cause harmful interference to radio communications. However, there is no guarantee that interferences will not occur in a particular installation. If the equipment does cause harmful interference to radio or television reception, the user is encouraged to try to correct the interference by one or more of the following measures:

- Reorient or relocate the receiving antenna.
- Increase the distance between the equipment and the receiver.
- Use a different line outlet for the receiver.
- Consult a radio or TV technician for help.

You are cautioned that any changes or modifications not expressly approved in this manual could void your authority to operate this equipment. The shielded interface cable recommended in this manual must be used with this equipment in order to comply with the limits for a computing device pursuant to Subpart A of Part 15 of FCC Rules.

### For customers in Canada

This apparatus complies with the Class A limits for radio noise emissions set out in the Radio Interference Regulations.

### Pour utilisateurs au Canada

Cet appareil est conforme aux normes classe A pour bruits radioélectriques, spécifiées dans le Règlement sur le brouillage radioélectrique.

### Life support applications

These products are not designed for use in life support appliances, devices, or systems where malfunction of these products can reasonably be expected to result in personal injury. Allied Vision Technologies customers using or selling these products for use in such applications do so at their own risk and agree to fully indemnify Allied Vision Technologies for any damages resulting from such improper use or sale.

### Trademarks

Unless stated otherwise, all trademarks appearing in this document of Allied Vision Technologies are brands protected by law.

### Warranty

The information provided by Allied Vision Technologies is supplied without any guarantees or warranty whatsoever, be it specific or implicit. Also, excluded are all implicit warranties concerning the negotiability, the suitability for specific applications or the non-breaking of laws and patents. Even if we assume that the information supplied to us is accurate, errors and inaccuracy may still occur.

### Copyright

All texts, pictures and graphics are protected by copyright and other laws protecting intellectual property. It is not permitted to copy or modify them for trade use or transfer, nor may they be used on websites.

### Allied Vision Technologies GmbH 11/2013

All rights reserved.

Managing Director: Mr. Frank Grube

Tax ID: DE 184383113

Headquarters:

Taschenweg 2a

D-07646 Stadtroda, Germany

Tel: +49 (0)36428 6770

Fax: +49 (0)36428 677-28

e-mail: [info@alliedvisiontec.com](mailto:info@alliedvisiontec.com)

# Contents

<b>Contacting Allied Vision Technologies .....</b>	<b>5</b>
<b>Introduction .....</b>	<b>6</b>
Document history .....	6
Conventions used in this manual .....	7
Styles .....	7
Symbols .....	7
Precautions .....	8
Cleaning optics .....	9
Identifying debris .....	9
Locating debris .....	9
Color cameras with IR filter .....	9
Cleaning with air .....	10
Contact cleaning .....	10
<b>Conformity .....</b>	<b>11</b>
<b>Specifications .....</b>	<b>12</b>
Prosilica GB650/650C .....	12
Prosilica GB660/660C .....	14
Prosilica GB1380/1380C .....	16
Prosilica GB2450/2450C .....	18
<b>Camera attribute highlights .....</b>	<b>20</b>
<b>Filters .....</b>	<b>21</b>
<b>Camera dimensions .....</b>	<b>22</b>
<b>Mechanical drawings .....</b>	<b>23</b>
Landscape sensor and inline connector .....	23
Landscape sensor and vertical connector .....	24
Portrait sensor and inline connector .....	25
Portrait sensor and vertical connector .....	26
Camera lens mount .....	27
Optical flange focal distance .....	28
Adjustment of lens mount .....	29
Loosen locking ring .....	29
Image to infinity .....	29
<b>Camera interfaces .....</b>	<b>30</b>
Status LEDs .....	30
Gigabit Ethernet port .....	31
Camera I/O connector pin assignment .....	32

---

I/O definition .....	33
Camera power .....	33
Isolated IO ground .....	33
RxD RS-232 and TxD RS-232 .....	33
Input triggers .....	34
Output signals.....	34
Signal ground .....	35
Video iris.....	35
Reserved .....	35
Camera I/O opto-isolated user circuit example .....	36
Camera I/O non-isolated user circuit example .....	37
Video iris user circuit example.....	38
Trigger timing diagram .....	39
Notes on triggering .....	39
<b>Firmware update</b> .....	<b>41</b>
<b>Resolution and ROI frame rates</b> .....	<b>42</b>
Prosilica GB650.....	42
Prosilica GB660.....	43
Prosilica GB1380 .....	43
Prosilica GB2450 .....	44
Prosilica GB model comparison .....	44
<b>Description of the data path</b> .....	<b>45</b>
Prosilica GB: monochrome cameras.....	45
Prosilica GB: color cameras .....	45
<b>Additional references</b> .....	<b>46</b>
<b>Index</b> .....	<b>47</b>

# Contacting Allied Vision Technologies

## Info



- **Technical information:**  
<http://www.alliedvisiontec.com>
- **Support:**  
[support@alliedvisiontec.com](mailto:support@alliedvisiontec.com)

### **Allied Vision Technologies GmbH (Headquarters)**

Taschenweg 2a  
07646 Stadtroda, Germany  
Tel: +49 36428-677-0  
Fax: +49 36428-677-28  
e-mail: [info@alliedvisiontec.com](mailto:info@alliedvisiontec.com)

### **Allied Vision Technologies Canada Inc.**

101-3750 North Fraser Way  
Burnaby, BC, V5J 5E9, Canada  
Tel: +1 604-875-8855  
Fax: +1 604-875-8856  
e-mail: [info@alliedvisiontec.com](mailto:info@alliedvisiontec.com)

### **Allied Vision Technologies Inc.**

38 Washington Street  
Newburyport, MA 01950, USA  
Toll Free number +1 877-USA-1394  
Tel: +1 978-225-2030  
Fax: +1 978-225-2029  
e-mail: [info@alliedvisiontec.com](mailto:info@alliedvisiontec.com)

### **Allied Vision Technologies Asia Pte. Ltd.**

82 Playfair Road  
#07-02 D'Lithium, Singapore 368001  
Tel: +65 6634-9027  
Fax: +65 6634-9029  
e-mail: [info@alliedvisiontec.com](mailto:info@alliedvisiontec.com)

### **Allied Vision Technologies (Shanghai) Co. Ltd.**

2-2109 Hongwell International Plaza  
1602# ZhongShanXi Road, Shanghai 200235, China  
Tel: +86 21-64861133  
Fax: +86 21-54233670  
e-mail: [info@alliedvisiontec.com](mailto:info@alliedvisiontec.com)

# Introduction

This **AVT Prosilica GB Technical Manual** describes in depth the technical specifications of the Prosilica GB camera family including dimensions, feature overview, I/O definition, trigger timing waveforms, and frame rate performance.

For information on software installation read the **AVT GigE Installation Manual**. For detailed information on camera features and controls specific to the Prosilica GB refer to the **AVT GigE Camera and Driver Features** and **AVT GigE Camera and Driver Attributes** documents.

www



**AVT Prosilica GB literature:**

<http://www.alliedvisiontec.com/us/support/downloads/product-literature/prosilica-gb.html>

## Document history

Version	Date	Remarks
V2.0.0	2011-Jul-14	New Manual - SERIAL status
V2.0.1	2013-Jan-28	<ul style="list-style-type: none"> <li>Renamed Camera IO signals</li> <li>Reworked cleaning optics section</li> <li>Reworked the spectral plots and frame rate vs.height graphs</li> </ul>
V2.0.2	2013-Apr-22	<ul style="list-style-type: none"> <li>Updated the RoHS directive</li> <li>Updated the exposure control values in the <a href="#">Specifications</a> chapter</li> <li>Added <a href="#">Status LEDs</a> section</li> <li>Updated the pixel format naming according to the GenICam naming convention</li> <li>Added frame rate formulas in the <a href="#">Resolution and ROI frame rates</a> chapter</li> <li>Added VIMBA SDK link in <a href="#">Additional references</a> section</li> <li>Updated AVT recommended cabling to category 6 or higher in <a href="#">Gigabit Ethernet port</a> section</li> </ul>
V2.0.3	2013-Jul-05	<ul style="list-style-type: none"> <li>Added contact information for Allied Vision Technologies (Shanghai) Co. Ltd.</li> <li>Updated the links to <b>AVT GigE Installation Manual</b></li> <li>Added links to <b>AVT GigE Camera and Driver Features</b> document</li> </ul>
<b>to be continued on next page</b>		

Table 1: Document history

Version	Date	Remarks
<b>continued from last page</b>		
V2.0.4	2013-Oct-02	<ul style="list-style-type: none"> <li>Added optical flange focal distance and maximum lens protrusion information on page 28</li> <li>Updated <i>Cleaning optics</i> section</li> <li>Updated vertical binning value for <i>Prosilica GB660/660C</i></li> <li>Updated <a href="#">table 7</a> on page 20</li> <li>Updated links to AVT PvAPI SDK</li> </ul>
V2.0.5	2013-Nov-26	<ul style="list-style-type: none"> <li>Added chapter <a href="#">Description of the data path</a> on page 45</li> <li>Added a note on camera lens mount dimensions in the following sections: <ul style="list-style-type: none"> <li><a href="#">Landscape sensor and inline connector</a></li> <li><a href="#">Landscape sensor and vertical connector</a></li> <li><a href="#">Portrait sensor and inline connector</a></li> <li><a href="#">Portrait sensor and vertical connector</a></li> </ul> </li> </ul>

Table 1: Document history

## Conventions used in this manual

To give this manual an easily understood layout and to emphasize important information, the following typographical styles and symbols are used:

### Styles

Style	Function	Example
Bold	Programs, inputs, or highlighting important information	<b>bold</b>
Courier	Code listings etc.	Input
Upper case	Register	REGISTER
Italics	Modes, fields	<i>Mode</i>
Parentheses and/or blue	Links	<a href="#">(Link)</a>

Table 2: Styles

### Symbols

**Note** \_\_\_\_\_ This symbol highlights important information.



**Caution**

This symbol highlights important instructions. You have to follow these instructions to avoid malfunctions.

**www**

This symbol highlights URLs for further information. The URL itself is shown in blue.



Example:

<http://www.alliedvisiontec.com>

## Precautions

**Caution**

**Do not disassemble the camera housing. Warranty is void if camera has been disassembled.**



This camera contains sensitive internal components.

**Caution**

**Keep shipping material.**



Poor packaging of the product may cause damage during shipping.

**Caution**

**Verify all external connections.**



Verify all external connections in terms of voltage levels, power requirements, voltage polarity, and signal integrity prior to powering the device.

**Caution**

**Cleaning.**



This product can be damaged by some volatile cleaning agents. Avoid cleaning the image sensor unless absolutely necessary. Please see instructions on optics cleaning in this document.

**Caution**

**Do not exceed environmental specifications.**



See environmental specifications limits in the [Specifications](#) section of this document. Special care must be taken to maintain a reasonable operating temperature. If the camera is operated in temperatures higher than the specified range, the camera should be mounted on a heat sink.



## Cleaning optics

### Caution



AVT does not warranty against any physical damage to the sensor/filter/protection glass or lenses. **Use utmost care when cleaning optical components.**

### Caution



**Do not touch any optics with fingers. Oil from fingers can damage fragile optical coatings.**

## Identifying debris

Debris on the image sensor or optical components appears as a darkened area or smudge on a camera image. Do not confuse this with a pixel defect which appears as a distinct point.

## Locating debris

First determine whether the debris is on the sensor glass, IR filter (if used), or lens. The farther away the debris is from the sensor, the blurrier the debris appears on a camera image.

Stream a live image from the camera using a uniform target, such as a piece of paper. To determine if the debris is on the camera lens, rotate the lens independent of the camera. If the spot moves, the debris is on the lens. Otherwise, the debris is on the IR filter (if used) or sensor glass.

## Color cameras with IR filter

Prosilica GB color cameras are equipped with an IR filter. With no lens or lens cap on a camera, the IR filter is exposed and debris can accumulate on it. This is the most probable location for debris. It should not be necessary to remove the IR filter for cleaning. Clean the outside of the IR filter glass using the techniques explained in the next section.

If it is determined that the debris is on the inside surface of the filter glass, or on the sensor glass, IR filter removal is necessary. Depending on the manufacturing date of your Prosilica GB camera, the IR filter may be slot type, or pinhole type. Slot type filters can be removed using a small flat head screw driver. Pinhole type filters require a pin spanner wrench for removal.

**Note**

A pin spanner wrench suitable for IR filter removal is available for purchase from AVT.  
AVT P/N: E9020001

**Cleaning with air**

Blow directly on the contaminated surface with moderate pressure, clean compressed air.

**Caution**

**Do not exceed 6 bar (90 psi). If using canned air, approximately ~4.8 bar (70 psi) when full, do not shake or tilt the can, as extreme changes in temperature due to sudden cold air can crack the optic glass.**

View a live image with the camera after blowing. If debris is still present, repeat the process until it is determined that the particulate cannot be dislodged. If this is the case, proceed to the contact cleaning technique.

**Contact cleaning**

Only use this method if the above air cleaning method does not sufficiently clean the surface. Use 99% pure isopropyl alcohol and clean cotton swabs. Wet the swab in the alcohol. Quickly wipe the optics in a single stroke. Prolonged exposure of alcohol on the swab can cause the swab glue to loosen and transfer to the optic glass. Do not reuse the same swab. Repeat this process until the debris is removed. If this process fails to remove the debris, contact AVT.

## Conformity

Allied Vision Technologies declares under its sole responsibility that all standard cameras of the **AVT Prosilica GB** family to which this declaration relates are in conformity with the following standard(s) or other normative document(s):

- CE, following the provisions of 2004/108/EG directive
- FCC Part 15 Class A
- RoHS (2011/65/EU)



We declare, under our sole responsibility, that the previously described **AVT Prosilica GB** cameras conform to the directives of the CE.



Note: This equipment has been tested and found to comply with the limits for a Class A digital device, pursuant to part 15 of the FCC Rules. These limits are designed to provide reasonable protection against harmful interference in a residential environment. This equipment generates radio frequency energy and, if not installed and used in accordance with the instructions, may cause harmful interference to radio communications. Any modifications not expressly approved in this manual may void your authority to operate this equipment.

# Specifications

## Prosilica GB650/650C

Feature	Specification
Resolution	659 x 493
Sensor	Sony ICX424AL, ICX424AQ for color
Type	CCD Progressive
Sensor size	Type 1/3
Cell size	7.4 $\mu\text{m}$
Lens mount	C (adjustable) / CS
Max frame rate at full resolution	120 fps
A/D	12 bit
On-board FIFO	16 MB
Bit depth	8/12
Mono formats	GB650: Mono8, Mono12, Mono12Packed; GB650C: Mono8
Color formats	BayerRG8, BayerRG12, BayerGR12Packed, RGB8Packed, BGR8Packed, YUV411Packed, YUV422Packed, YUV444Packed
Exposure control	10 $\mu\text{s}$ to 78.5 s; 1 $\mu\text{s}$ increments
Gain control	0 to 30 dB
Horizontal binning	1 to 8 pixels
Vertical binning	1 to 14 rows
TTL I/Os	1 input, 1 output
Opto-coupled I/Os	1 input, 1 output
RS-232	1
Power requirements	5–16 VDC: Cameras SN: 02-22XXA; 5–25 VDC: Cameras SN: 02-22XXB
Power consumption	3 W
Mass	59 g
Dimensions	51 x 89 mm (board size - W x L)
Sensor orientations	Landscape, portrait
Connector orientations	Inline, vertical
Operating temperature	0 to +70 °C ambient temperature (without condensation)
Storage temperature	-10 to +70 °C ambient temperature (without condensation)
Trigger latency	1.0 $\mu\text{s}$ for non-isolated I/O, 9 $\mu\text{s}$ for isolated I/O
Trigger jitter	$\pm 20$ ns for non-isolated I/O, $\pm 0.5$ $\mu\text{s}$ for isolated I/O
Tpd	10 ns for non-isolated I/O, 1.3 $\mu\text{s}$ for isolated I/O
Operating humidity	20 to 80% non-condensing
Hardware interface standard	IEEE 802.3 1000BASE-T, 100BASE-TX
Software interface standard	GigE Vision Standard 1.2
Regulatory	CE, FCC Class A, RoHS (2011/65/EU)

Table 3: Prosilica GB650/650C camera specifications

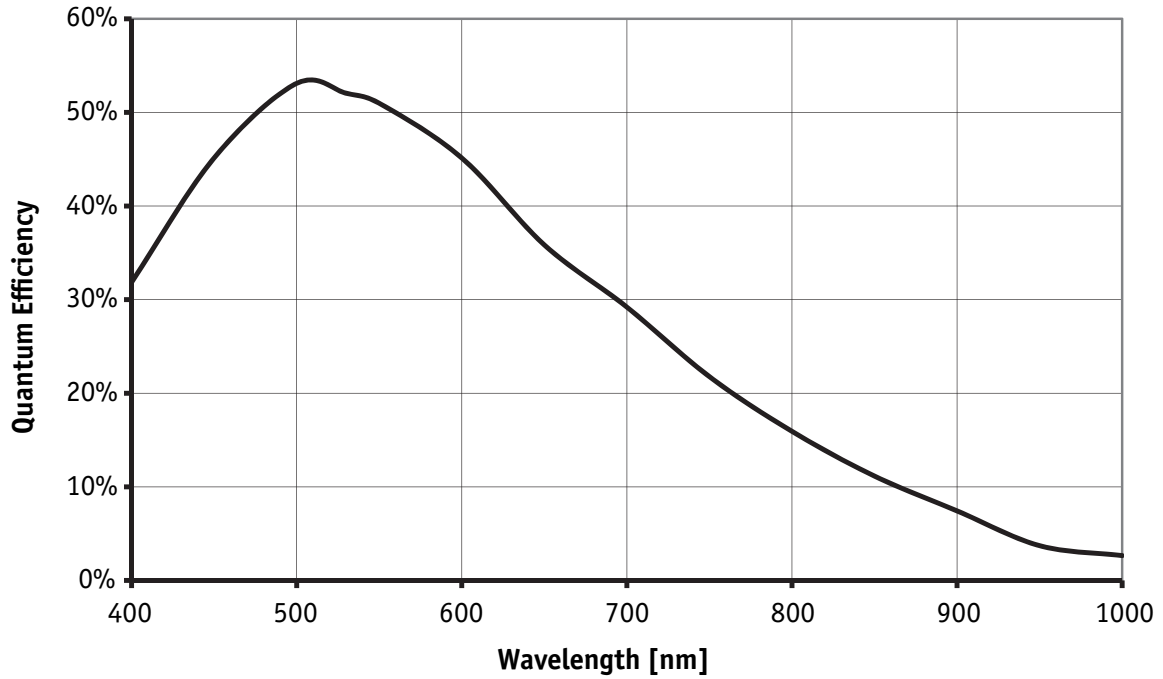

Figure 1: Prosilica GB650 monochrome spectral response

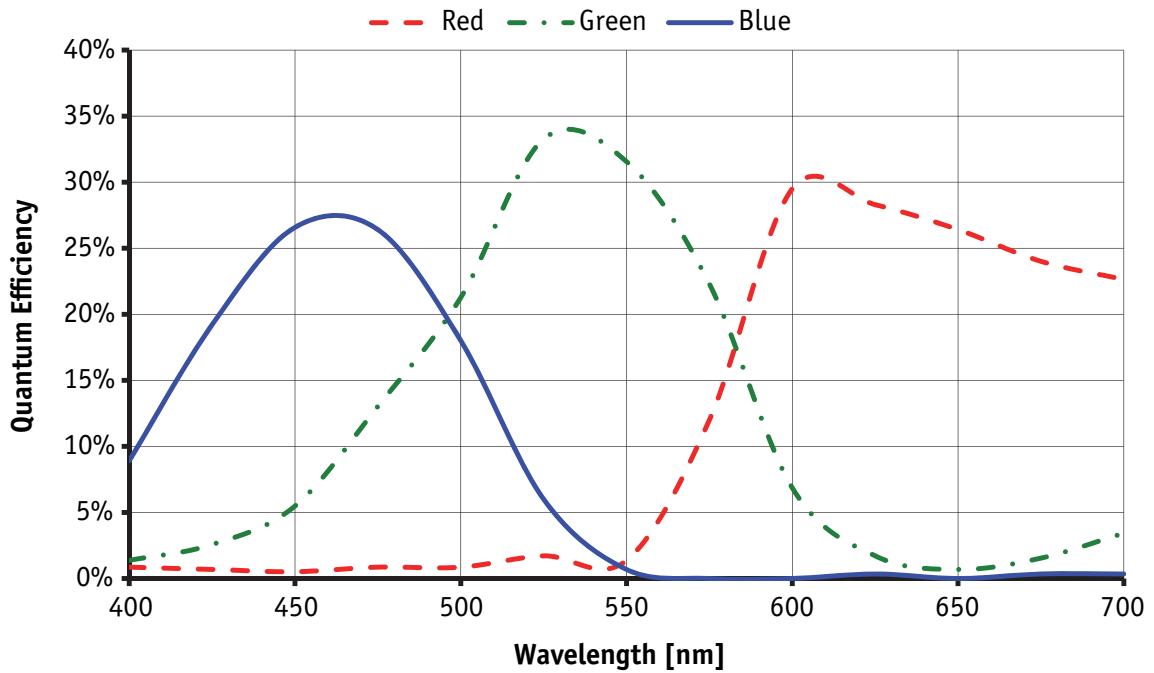

Figure 2: Prosilica GB650C color spectral response (without IR cut filter)

## Prosilica GB660/660C

Feature	Specification
Resolution	659 x 493
Sensor	Sony ICX618
Type	CCD Progressive
Sensor size	Type 1/4
Cell size	5.6 $\mu\text{m}$
Lens mount	C (adjustable) / CS
Max frame rate at full resolution	119 fps
A/D	14 bit
On-board FIFO	16 MB
Bit depth	8/12
Mono formats	GB660: Mono8, Mono12, Mono12Packed; GB660C: Mono8
Color formats	BayerRG8, BayerRG12, BayerGR12Packed, RGB8Packed, BGR8Packed, YUV411Packed, YUV422Packed, YUV444Packed
Exposure control	10 $\mu\text{s}$ to 78.5 s; 1 $\mu\text{s}$ increments
Gain control	0 to 30 dB
Horizontal binning	1 to 8 pixels
Vertical binning	1 to 14 rows
TTL I/Os	1 input, 1 output
Opto-coupled I/Os	1 input, 1 output
RS-232	1
Power requirements	5–16 VDC: Cameras SN: 02-22XXA 5–25 VDC: Cameras SN: 02-22XXB
Power consumption	3 W
Mass	59 g
Dimensions	51 x 89 mm (board size - W x L)
Sensor orientations	Landscape
Connector orientations	Inline, vertical
Operating temperature	0 to +70 °C ambient temperature (without condensation)
Storage temperature	-10 to +70 °C ambient temperature (without condensation)
Trigger latency	2 $\mu\text{s}$ for non-isolated I/O, 10 $\mu\text{s}$ for isolated I/O
Trigger jitter	$\pm 20$ ns for non-isolated I/O, $\pm 0.5$ $\mu\text{s}$ for isolated I/O
Tpd	10 ns for non-isolated I/O, 1.3 $\mu\text{s}$ for isolated I/O
Operating humidity	20 to 80% non-condensing
Hardware interface standard	IEEE 802.3 1000BASE-T, 100BASE-TX
Software interface standard	GigE Vision Standard 1.2
Regulatory	CE, FCC Class A, RoHS (2011/65/EU)

Table 4: Prosilica GB660/660C camera specifications

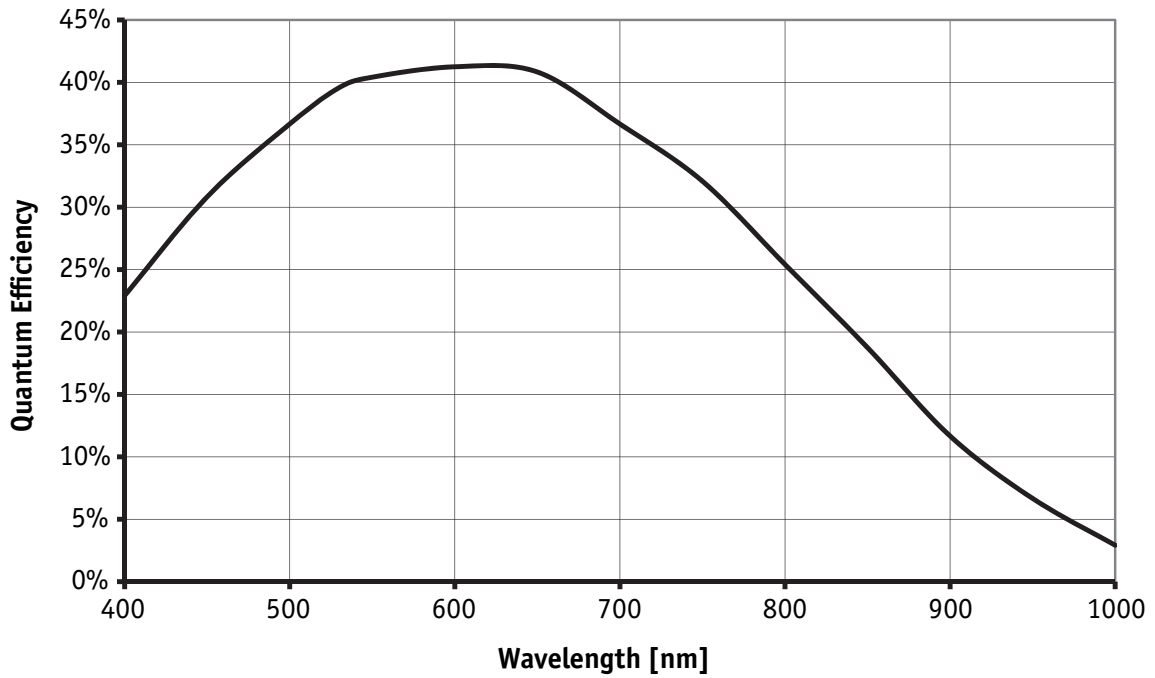

Figure 3: Prosilica GB660 monochrome spectral response

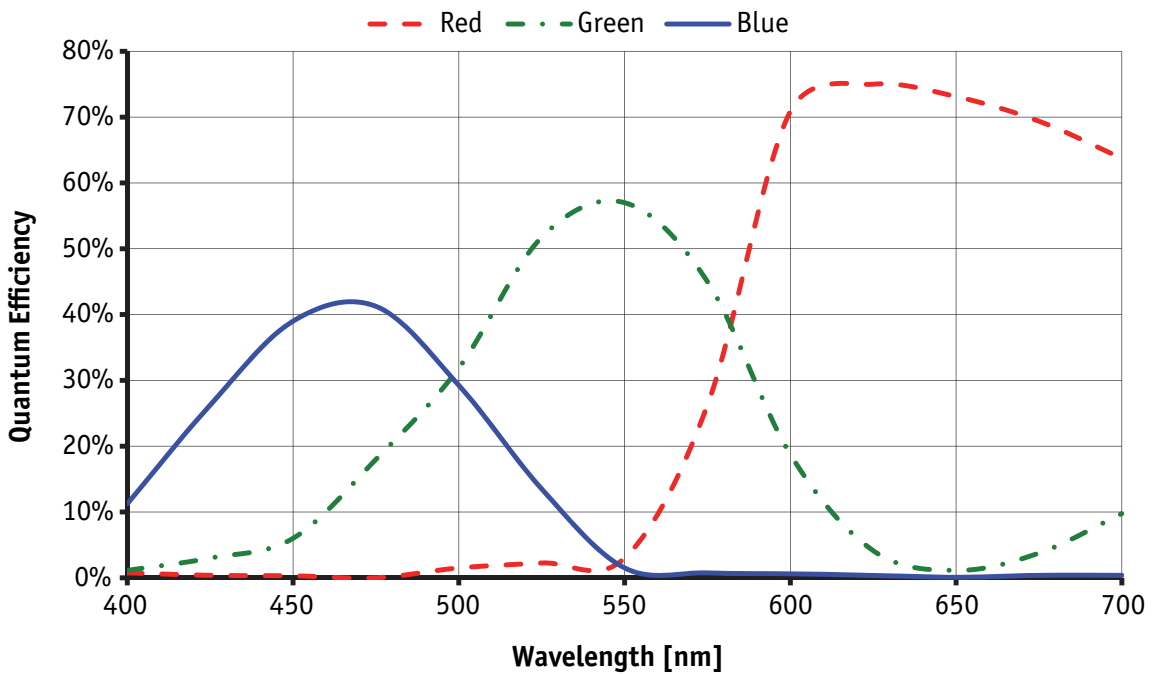

Figure 4: Prosilica GB660C color spectral response (without IR cut filter)

## Prosilica GB1380/1380C

Feature	Specification
Resolution	1360 x 1024
Sensor	Sony ICX285AL CCD (ICX285AQ for color)
Type	CCD Progressive
Sensor size	Type 2/3
Cell size	6.45 $\mu\text{m}$
Lens mount	C (adjustable) / CS
Max frame rate at full resolution	30 fps
A/D	14 bit
On-board FIFO	16 MB
Bit depth	8/12
Mono formats	GB1380: Mono8, Mono12, Mono12Packed; GB1380C: Mono8
Color formats	BayerRG8, BayerRG12, BayerGR12Packed, RGB8Packed, BGR8Packed, YUV411Packed, YUV422Packed, YUV444Packed
Exposure control	10 $\mu\text{s}$ to 78.5 s; 1 $\mu\text{s}$ increments
Gain control	0 to 30 dB
Horizontal binning	1 to 8 pixels
Vertical binning	1 to 14 rows
TTL I/Os	1 input, 1 output
Opto-coupled I/Os	1 input, 1 output
RS-232	1
Power requirements	5–16 VDC: Cameras SN: 02-22XXA 5–25 VDC: Cameras SN: 02-22XXB
Power consumption	3 W
Mass	59 g
Dimensions	51 x 89 mm (board size - W x L)
Sensor orientations	Landscape, portrait
Connector orientations	Inline, vertical
Operating temperature	0 to +70 °C ambient temperature (without condensation)
Storage temperature	-10 to +70 °C ambient temperature (without condensation)
Trigger latency	1 $\mu\text{s}$ for non-isolated I/O, 9 $\mu\text{s}$ for isolated I/O
Trigger jitter	$\pm 20$ ns for non-isolated I/O, $\pm 0.5$ $\mu\text{s}$ for isolated I/O
Tpd	10 ns for non-isolated I/O, 1.3 $\mu\text{s}$ for isolated I/O
Operating humidity	20 to 80% non-condensing
Hardware interface standard	IEEE 802.3 1000BASE-T, 100BASE-TX
Software interface standard	GigE Vision Standard 1.2
Regulatory	CE, FCC Class A, RoHS (2011/65/EU)

Table 5: Prosilica GB1380/1380C camera specifications



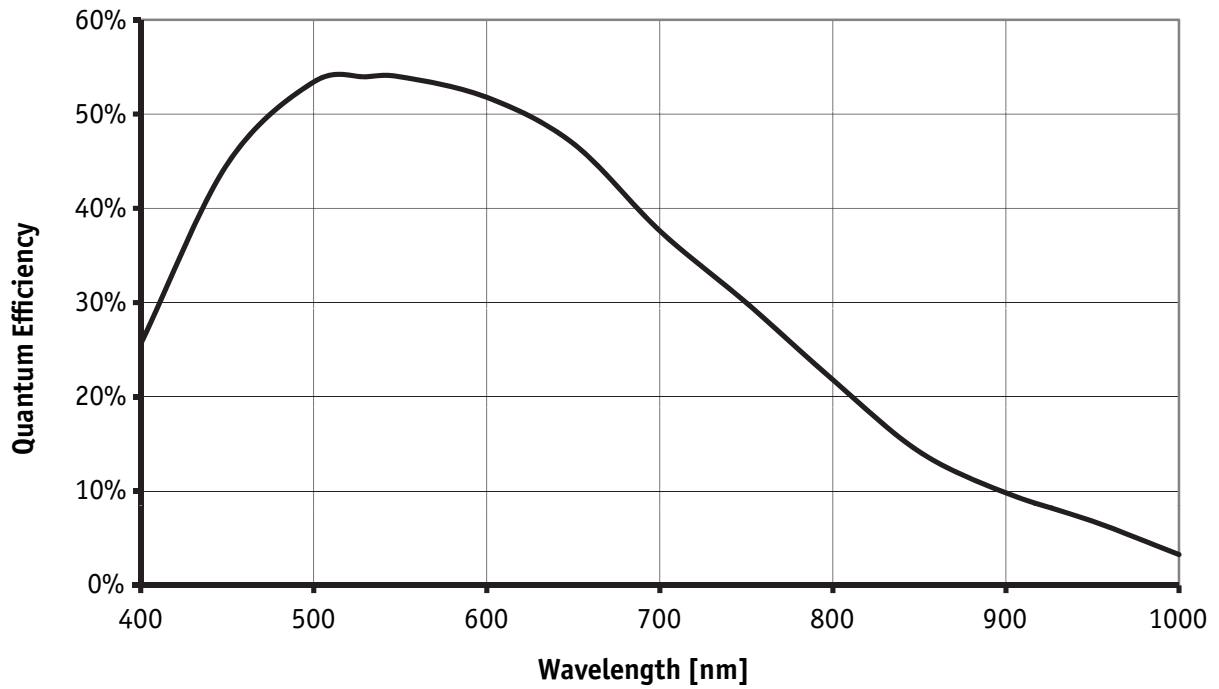

Figure 5: Prosilica GB1380 monochrome spectral response

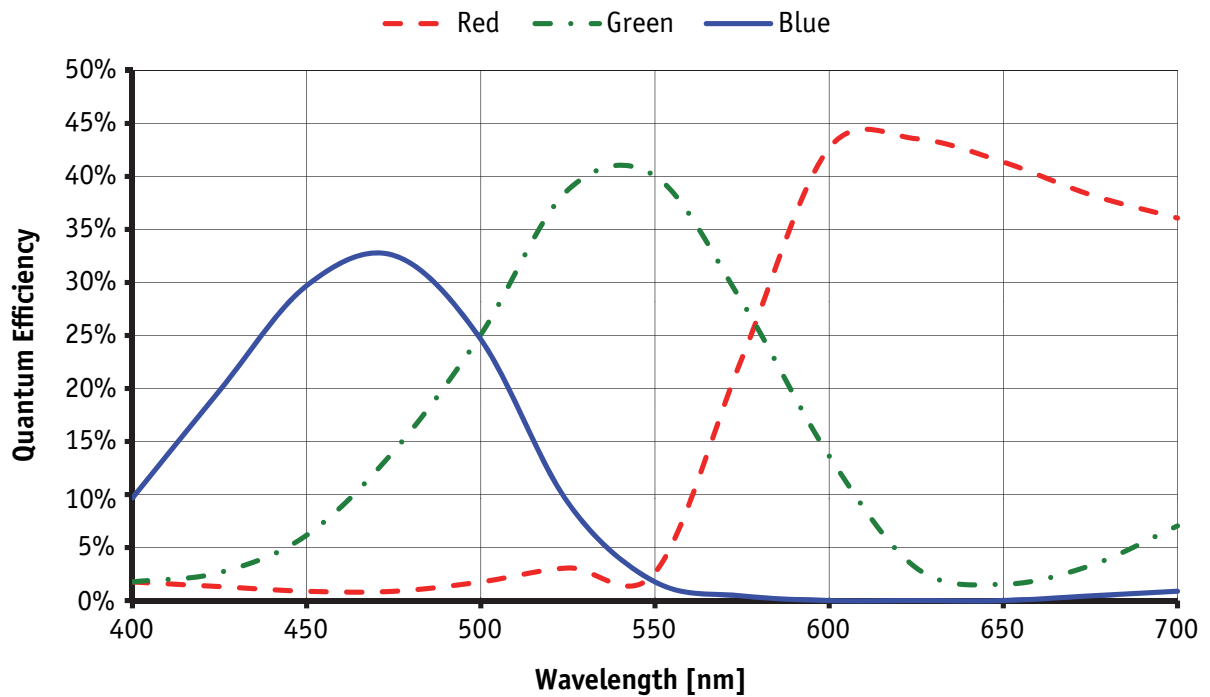

Figure 6: Prosilica GB1380C color spectral response (without IR cut filter)

## Prosilica GB2450/2450C

Feature	Specification
Resolution	2448 x 2050
Sensor	Sony ICX625
Type	CCD Progressive
Sensor size	Type 2/3
Cell size	3.45 $\mu\text{m}$
Lens mount	C (adjustable) / CS
Max frame rate at full resolution	15 fps
A/D	14 bit
On-board FIFO	16 MB
Bit depth	8/12
Mono formats	GB2450: Mono8, Mono12, Mono12Packed; GB2450C: Mono8
Color formats	BayerRG8, BayerRG12, BayerGR12Packed, RGB8Packed, BGR8Packed, YUV411Packed, YUV422Packed, YUV444Packed
Exposure control	10 $\mu\text{s}$ to 42.9 s; 1 $\mu\text{s}$ increments
Gain control	0 to 30 dB
Horizontal binning	1 to 8 pixels
Vertical binning	1 to 14 rows
TTL I/Os	1 input, 1 output
Opto-coupled I/Os	1 input, 1 output
RS-232	1
Power requirements	5–16 VDC: Cameras SN: 02-22XXA 5–25 VDC: Cameras SN: 02-22XXB
Power consumption	3 W
Mass	54 g
Dimensions	51 x 89 mm (board size - W x L)
Sensor orientations	Landscape
Connector orientations	Inline, vertical
Operating temperature	0 to +70 °C ambient temperature (without condensation)
Storage temperature	-10 to +70 °C ambient temperature (without condensation)
Trigger latency	2 $\mu\text{s}$ for non-isolated I/O, 10 $\mu\text{s}$ for isolated I/O
Trigger jitter	$\pm 20$ ns for non-isolated I/O, $\pm 0.5$ $\mu\text{s}$ for isolated I/O
Tpd	10 ns for non-isolated I/O, 1.3 $\mu\text{s}$ for isolated I/O
Operating humidity	20 to 80% non-condensing
Hardware interface standard	IEEE 802.3 1000BASE-T, 100BASE-TX
Software interface standard	GigE Vision Standard 1.2
Regulatory	CE, FCC Class A, RoHS (2011/65/EU)

Table 6: Prosilica GB2450/2450C camera specifications

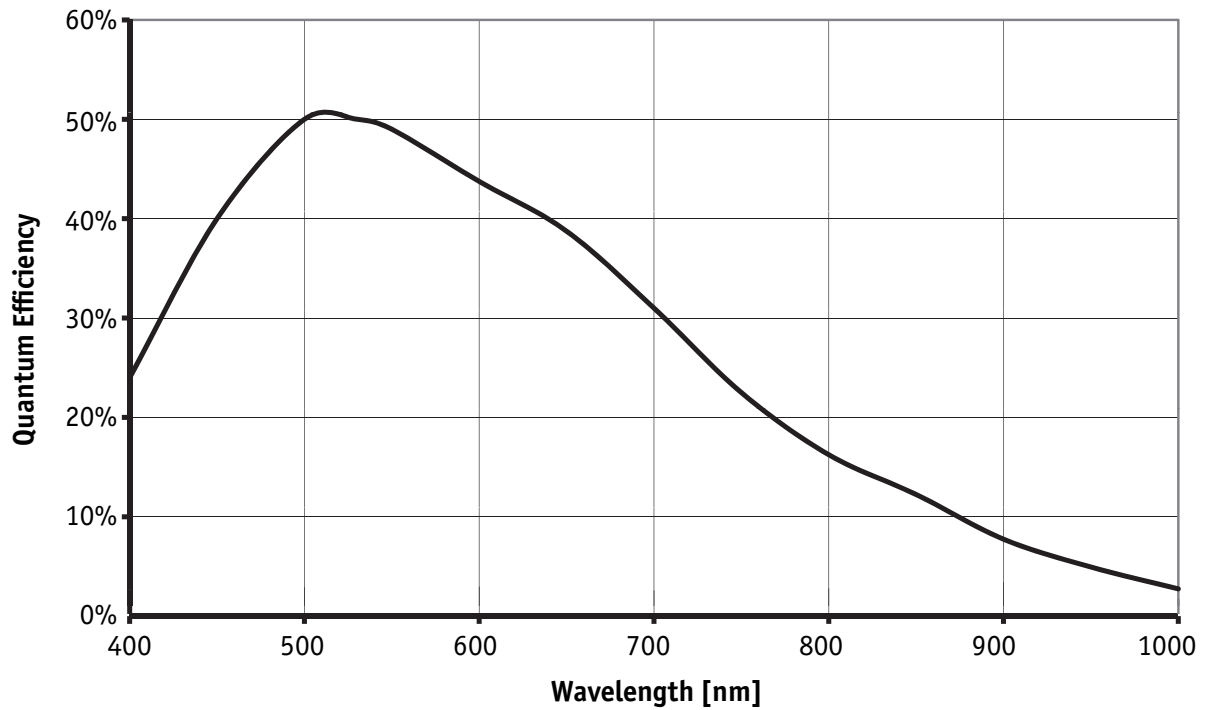

Figure 7: Prosilica GB2450 monochrome spectral response

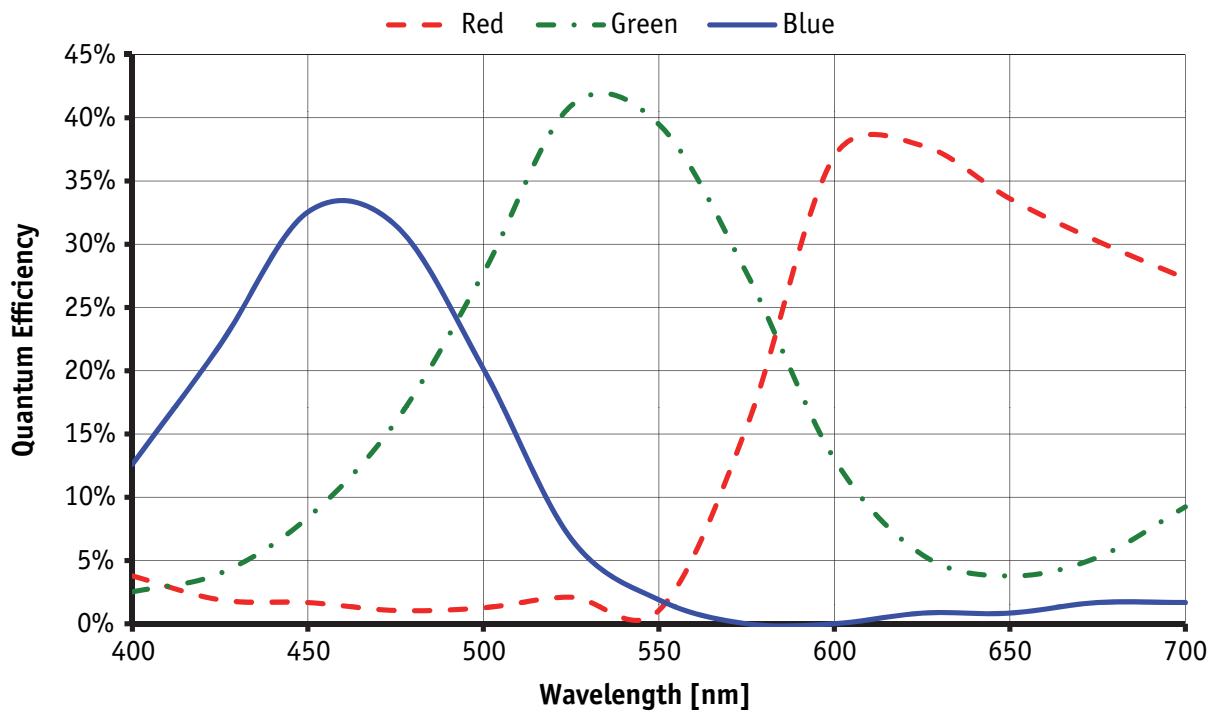



Figure 8: Prosilica GB2450C color spectral response (without IR cut filter)

# Camera attribute highlights

AVT cameras support a number of standard and extended features. The table below identifies a selection of interesting capabilities of the Prosilica GB camera family.

**www**  A complete listing of camera controls, including control definitions can be found online:



**PvAPI users:** [AVT GigE Camera and Driver Attributes](#) document

**VIMBA users:** [AVT GigE Camera and Driver Features](#) document

Control	Description
Gain control	Manual and auto
Exposure control	Manual and auto
White balance	Red and blue channel; manual and auto control
External trigger event	Rising edge, falling edge, any edge, level high, level low
External trigger delay	0 to 60* s; 1 $\mu$ s increments
Fixed rate control	0.001 fps to maximum frame rate
Imaging modes	Free-running, external trigger, fixed rate, software trigger
Sync out modes	Trigger ready, trigger input, exposing, readout, imaging, strobe, GPO
Region of interest	Independent x and y control with 1 pixel resolution
Multicast	Streaming to multiple computers
Event channel	In-camera events including exposure start and trigger are asynchronously broadcasted to the host computer
*May vary depending on the camera model	

Table 7: Prosilica GB camera and driver attribute highlights

## Filters

All Prosilica GB color models are equipped with an infrared block filter (IR filter). This filter is employed to prevent infrared wavelength photons from passing to the sensor. In the absence of IR filter, images are dominated by red and incapable of being properly color balanced. Monochrome cameras do not employ an IR filter.

The figure below shows the filter transmission response for the IRC30 filter employed in the Prosilica GB cameras.

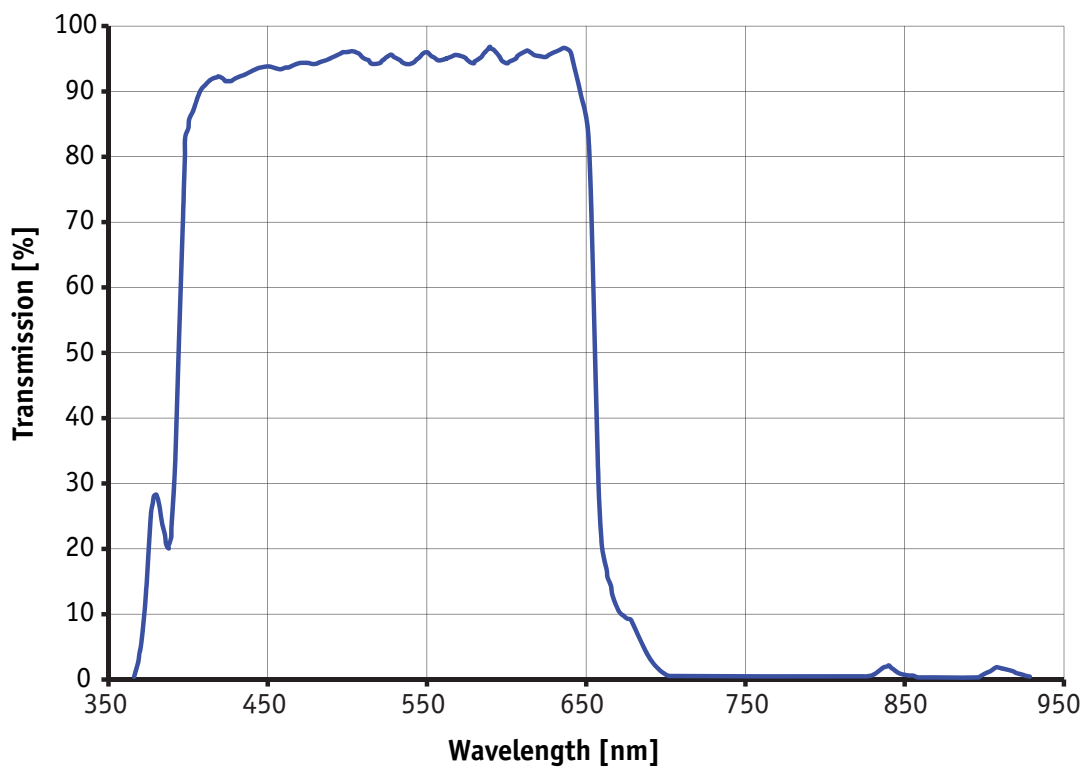

Figure 9: IRC30 filter transmission response

# Camera dimensions

The Prosilica GB camera is a board level product which offers several sensor and connector orientation options. The camera variations are described below and detailed dimension drawings are provided in the next section.

Sensor orientation	Model	Description	Example
Landscape 	GB	Sensor mounted in landscape orientation	GB1380, GS1380
Portrait 	GB-P	Sensor mounted in portrait orientation	GB1380-P, GS1380-P

Table 8: Prosilica GB sensor orientations

**Note** GB660/660C and GB2450/2450C do not support a portrait sensor orientation.

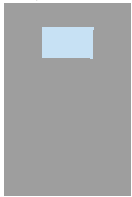
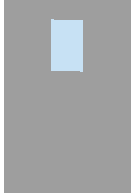

Connector orientation	Model	Description	Example
Inline 	GB	Ethernet and I/O connectors are in parallel with camera board	GB1380
Vertical 	GB-V	Ethernet and I/O connectors are perpendicular to camera board	GB1380-V

Table 9: Prosilica GB connector orientations

# Mechanical drawings

## Landscape sensor and inline connector

**Note**

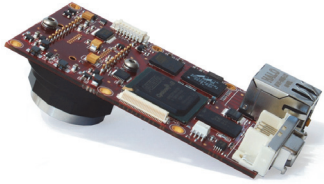
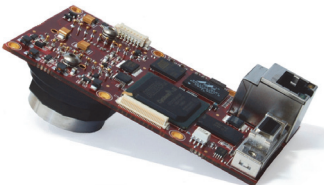
Assembly shown below is without the camera lens mount. See figure 14 for lens mount dimensions.

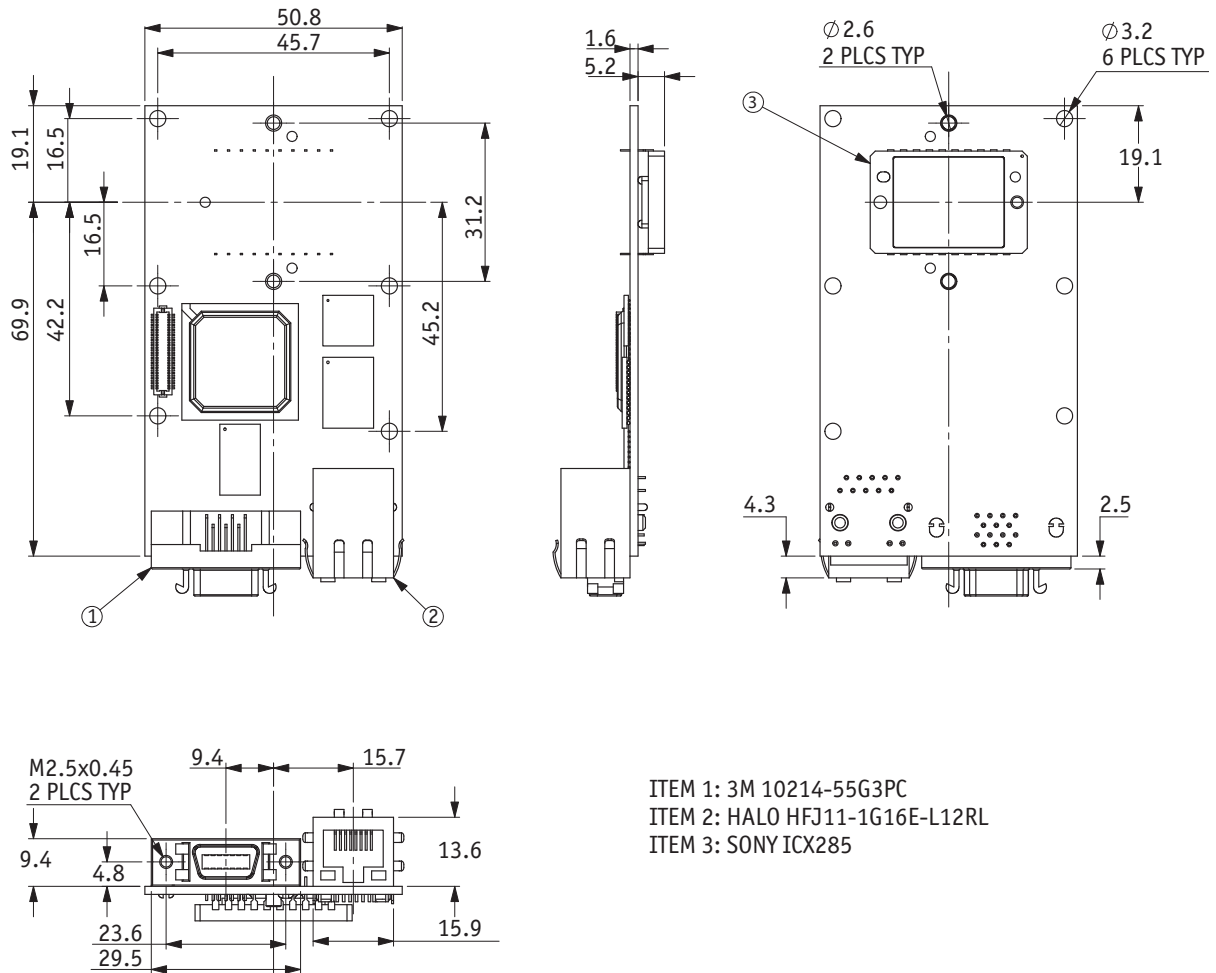

Figure 10: Prosilica GB1380/GB1380C mechanical drawing

# Landscape sensor and vertical connector

**Note**

Assembly shown below is without the camera lens mount. See figure 14 for lens mount dimensions.

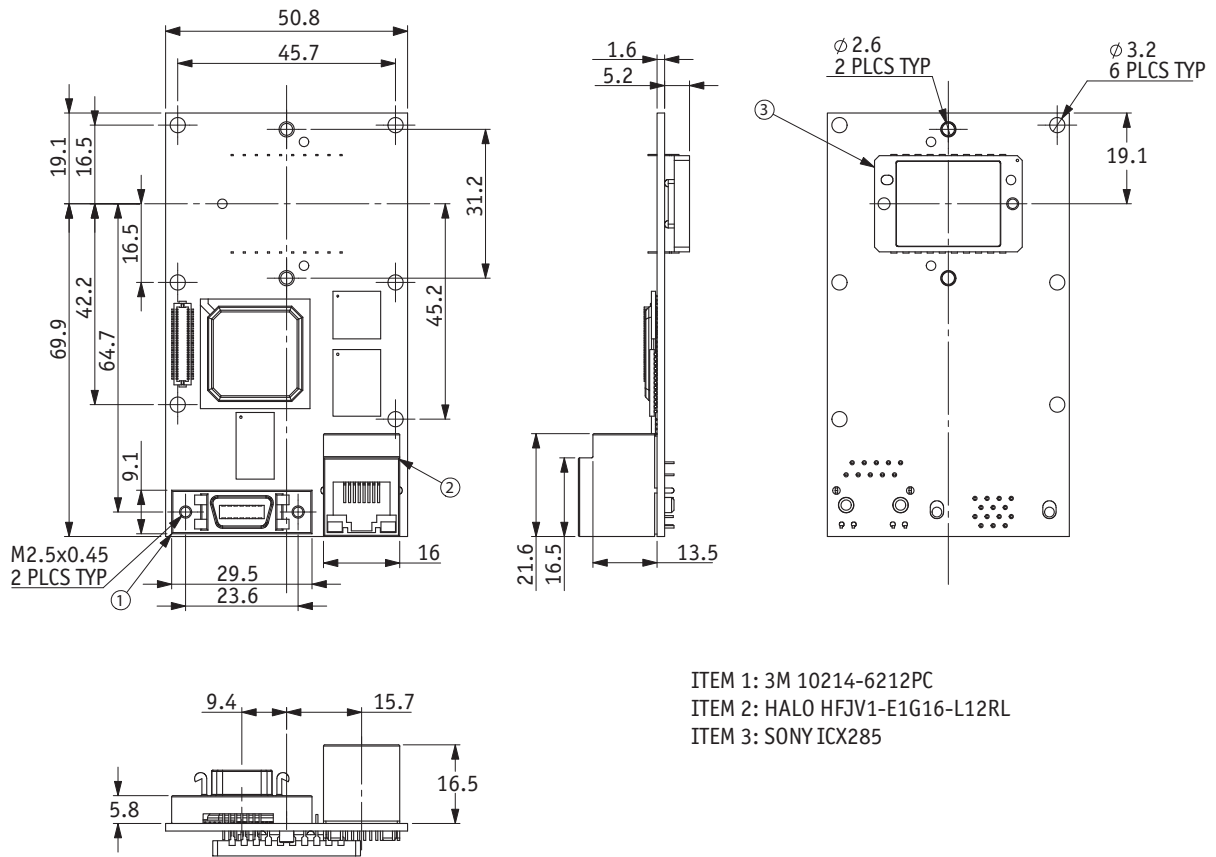

Figure 11: Prosilica GB1380-V/GB1380C-V mechanical drawing



# Portrait sensor and inline connector

**Note**

Assembly shown below is without the camera lens mount. See figure 14 for lens mount dimensions.

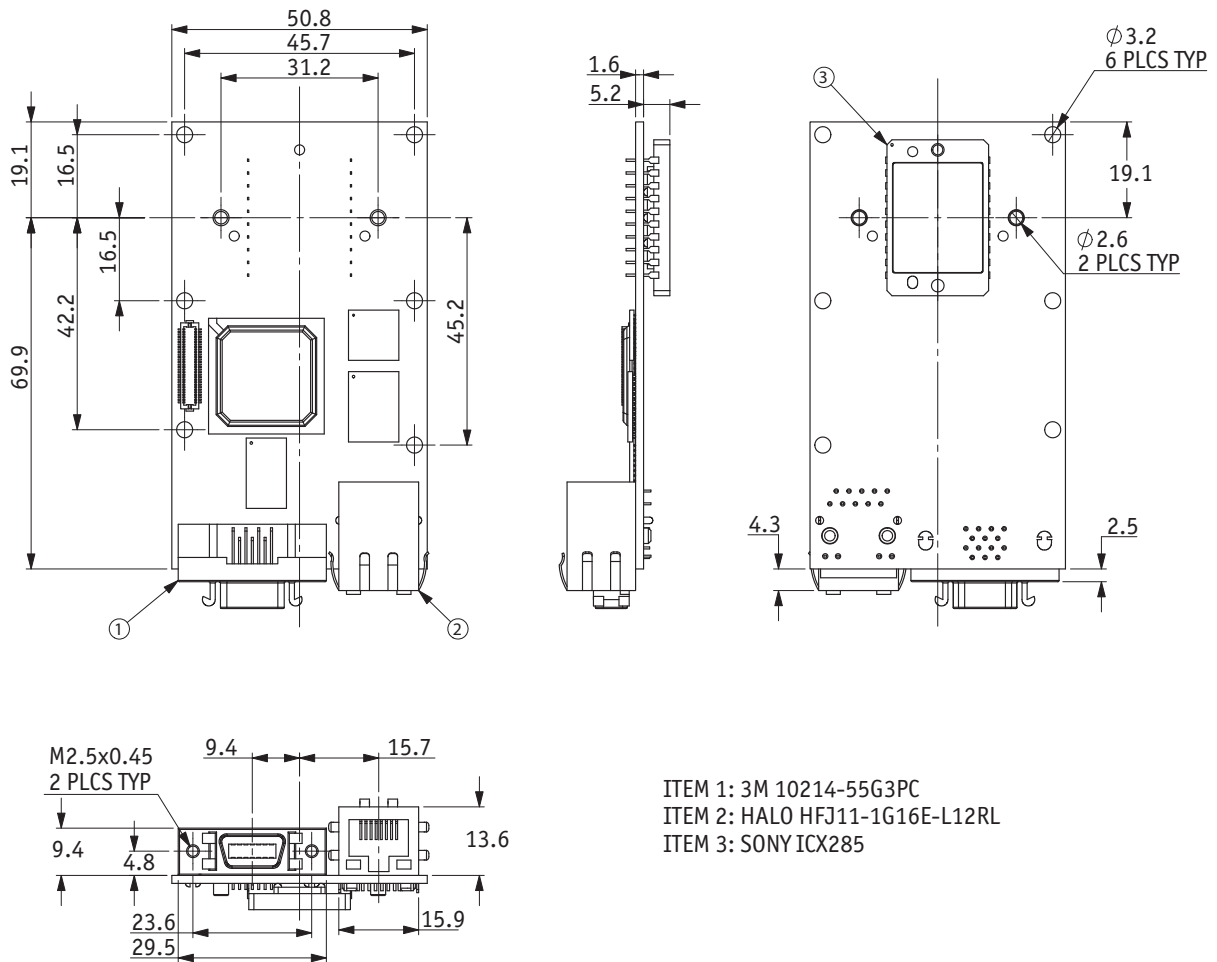

Figure 12: Prosilica GB1380-P/GB1380C-P mechanical drawing

# Portrait sensor and vertical connector

**Note**

Assembly shown below is without the camera lens mount. See figure 14 for lens mount dimensions.

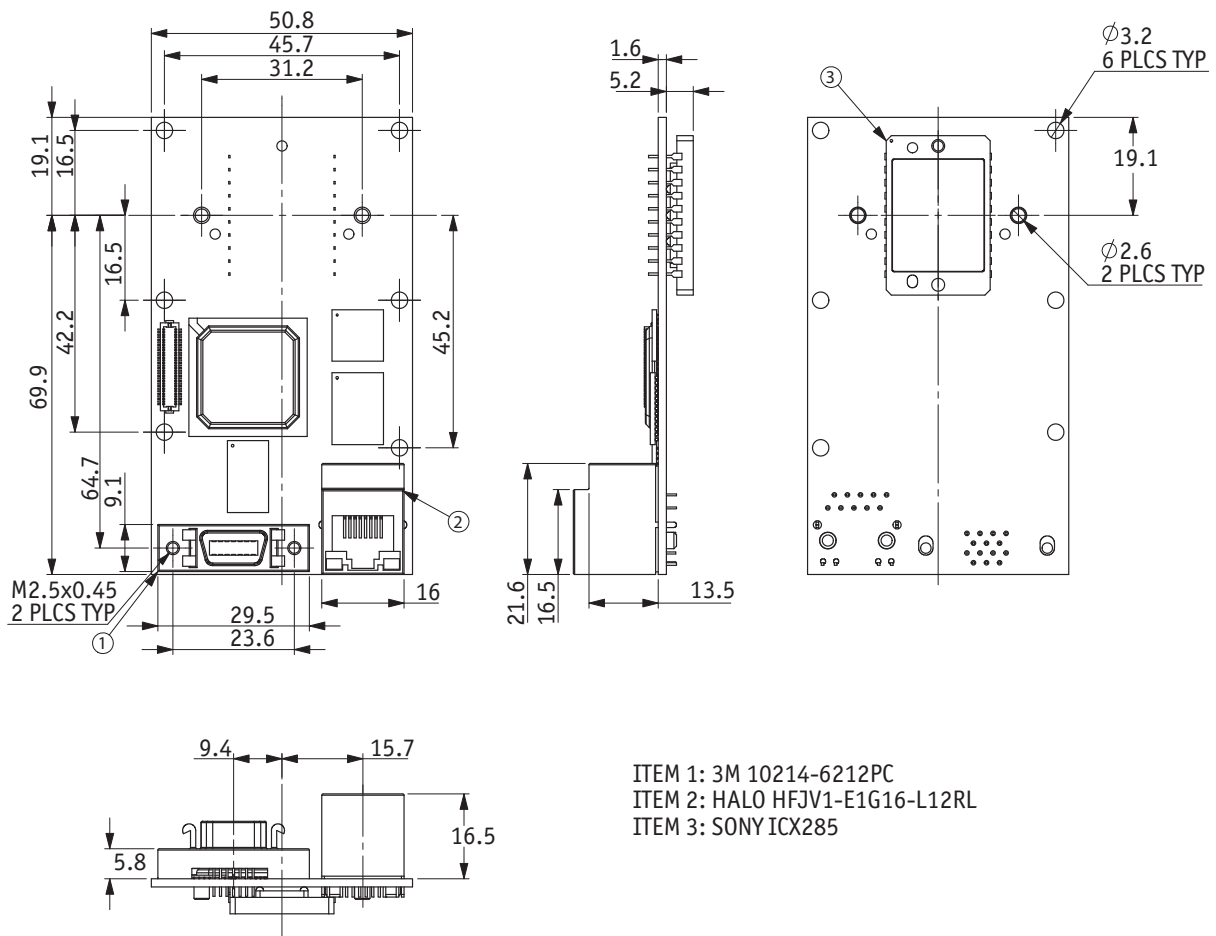

Figure 13: Prosilica GB1380-PV/GB1380C-PV mechanical drawing

## Camera lens mount

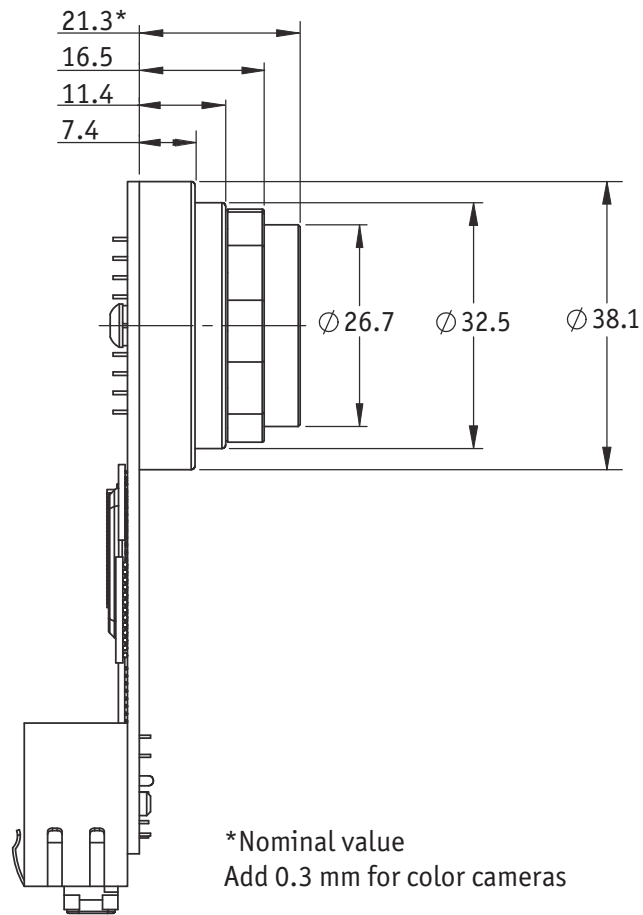

Figure 14: Prosilica GB lens mount

## Optical flange focal distance

Optical flange focal distance is the optical distance from the mounting flange to the image sensor die (see figure 15). Optical flange focal distance can be calculated as:

$$\text{Optical flange focal distance} \approx \text{Flange focal distance} - \left( \frac{\text{IR cut filter thickness} + \text{Sensor window thickness}}{3} \right)$$

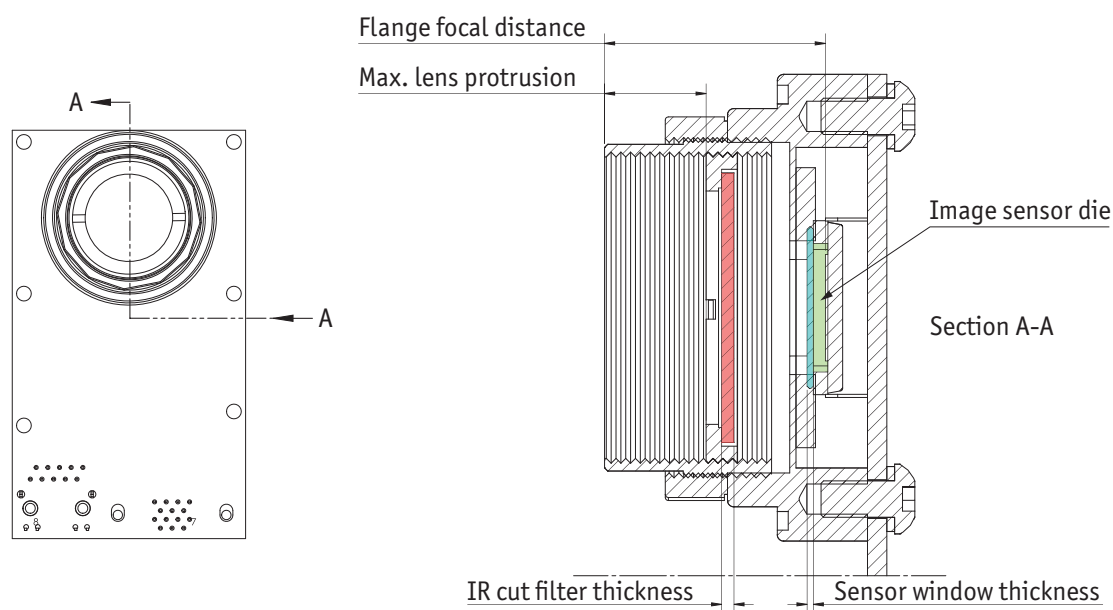

Figure 15: Cross section of typical Prosilica GB front assembly with C-Mount

Camera	Sensor orientation	Lens protrusion [mm]	IR cut filter* [mm]	Sensor window [mm]	Nominal flange focal distance [mm]
GB650C	Landscape	8.88	1.00	0.76	18.11
GB650C	Portrait	9.27	1.00	0.76	18.11
GB650	Landscape	13.64	0.00	0.75	17.78
GB650	Portrait	13.64	0.00	0.75	17.78
GB660C	Landscape	8.41	1.00	0.75	18.11
GB660	Landscape	13.64	0.00	0.75	17.78
GB1380C	Landscape	8.88	1.00	0.75	18.11
GB1380C	Portrait	9.32	1.00	0.75	18.11
GB1380	Landscape	13.64	0.00	0.75	17.78
GB1380	Portrait	13.64	0.00	0.75	17.78
GB2450C	Landscape	8.29	1.00	0.50	18.03
GB2450	Landscape	13.64	0.00	0.50	17.69

\* Only color camera models are equipped with IR cut filter.

Table 10: Flange focal distance and maximum lens protrusion for Prosilica GB cameras with C-Mount

## Adjustment of lens mount

www



Prosilica GB cameras can be equipped with an adjustable C-Mount or a CS-Mount depending on sensor size and camera order code. **AVT Modular Concept** for more information:

<http://www.alliedvisiontec.com/us/support/downloads/product-literature/avt-modular-concept.html>

The C-Mount or CS-Mount is adjusted at the factory and should not require adjusting. If for some reason the lens mount requires adjustment, use the following method.

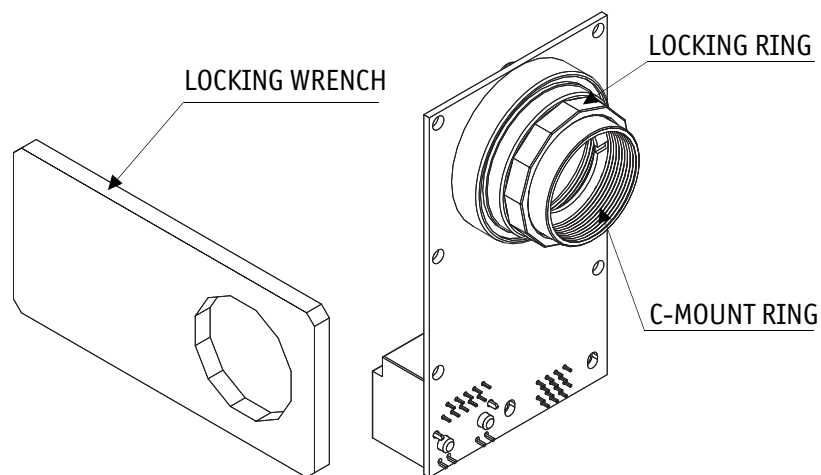

Figure 16: Prosilica GB camera front view

### Loosen locking ring

Use an adjustable wrench to loosen the locking ring. Be careful not to scratch the camera. When the locking ring is loose, unthread the ring a few turns from the camera face.

Note

A wrench suitable for this procedure is available for purchase from AVT.

AVT P/N: 02-5003A



### Image to infinity

Use a C-Mount compatible lens (CS-Mount compatible lens, if using CS ring) that allows an infinity focus. Set the lens to infinity and image a distant object—10 to 15 m should suffice. Make sure the lens is firmly threaded onto the C-Mount ring. Rotate the lens and C-Mount ring until the image is focused. Carefully tighten the locking ring and recheck focus.

# Camera interfaces

This chapter provides information on Gigabit Ethernet port, inputs and outputs, and trigger features.

www



For more information on GigE accessories:  
<http://www.alliedvisiontec.com/emea/products/accessories/gige-accessories.html>

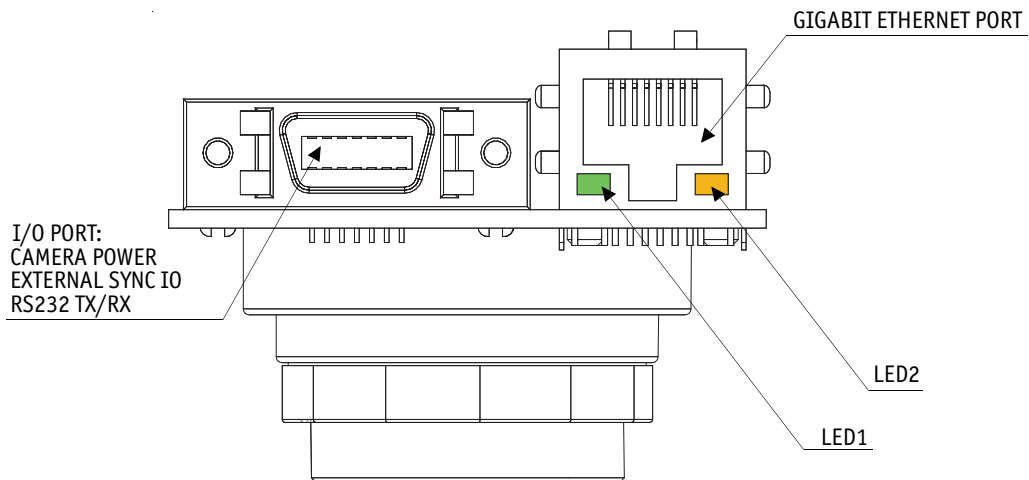

Figure 17: Prosilica GB connection ports

## Status LEDs

The color of the LEDs have the following meaning:

LED Color		Status
LED1	Flashing green	Camera is powered
	Solid green	Camera is booted, and link with the host is established
LED2	Flashing/solid orange	Ethernet activity

Table 11: Status of LEDs in Prosilica GB

**Note**



Once the camera is booted, LED1 will remain solid green as long as the camera is powered, even if connection with the host is lost.

## Gigabit Ethernet port

The Gigabit Ethernet port conforms to the IEEE 802.3 1000BASE-T standard for Gigabit Ethernet over copper. We recommend using Category 6 or higher compatible cabling and connectors for best performance.

### www

The **AVT GigE Installation Manual** offers detailed instructions for using Prosilica GB cameras.



[http://www.alliedvisiontec.com/fileadmin/content/PDF/Products/Technical\\_Manual/GigE\\_Install\\_Manual/AVT\\_GigE\\_Installation\\_Manual.pdf](http://www.alliedvisiontec.com/fileadmin/content/PDF/Products/Technical_Manual/GigE_Install_Manual/AVT_GigE_Installation_Manual.pdf)

### Note

See **Hardware Selection for AVT GigE Cameras** application note for a list of recommended Ethernet adapters:



[http://www.alliedvisiontec.com/fileadmin/content/PDF/Support/Application\\_Notes/Hardware\\_Selection\\_for\\_AVT\\_GigE\\_Cameras.pdf](http://www.alliedvisiontec.com/fileadmin/content/PDF/Support/Application_Notes/Hardware_Selection_for_AVT_GigE_Cameras.pdf)

A standard Ethernet adapter is available for purchase from AVT:  
AVT P/N: 02-3002A  
Model: Intel Pro 1000/PT

### Note

Cable lengths up to 100 m are supported.



The 8-pin RJ-45 jack has the pin assignment according to the Ethernet standard (IEEE 802.3 1000BASE-T).

Cables with screw-lock connectors are available for purchase from AVT:

<http://www.alliedvisiontec.com/emea/products/accessories/gige-accessories.html>

## Camera I/O connector pin assignment

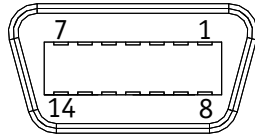

Pin	Signal	Direction	Level	Description
1	Camera Power	In	5–16* VDC	Power supply
2	Camera GND	In	GND for ext. power	Ground for camera power supply
3	In 1	In	$U_{in}(\text{high}) = 5\text{--}24\text{ V}$ $U_{in}(\text{low}) = 0\text{--}0.8\text{ V}$	Input 1 opto-isolated (SyncIn1)
4	Isolated IO GND	In/Out	Common GND for In/Out	Isolated input and output signal ground
5	Out 1	Out	Open emitter max. 20 mA	Output 1 opto-isolated (SyncOut1)
6	Video Iris	Out	---	PWM signal for iris control
7	Reserved	---	---	---
8	Camera Power	In	5–16* VDC	Power supply
9	Camera GND	Out	GND for ext. power	Ground for camera power supply
10	TxD RS-232	Out	RS-232	Terminal transmit data
11	RxD RS-232	In	RS-232	Terminal receive data
12	In 2	In	LVTTTL max. 3.3 V	Input 2 non-isolated (SyncIn2)
13	Out 2	Out	LVTTTL max. 3.3 V	Output 2 non-isolated (SyncOut2)
14	Signal GND	---	---	Ground for RS-232 and non-isolated outputs

\*Some models offer 5–25 VDC. See [Camera power](#) section for details.

Figure 18: Camera I/O connector pin assignment

The General Purpose I/O port uses a 3M 10214-55G3PC (or 3M 10214-6212PC) connector on the camera side. The mating cable connector is 3M 10114-3000PE or a connector with shielded housing 3M 10314-3210-00X (X indicates color preference).

### Note

The cable side Hirose connector is available for purchase from AVT.

AVT P/N: 02-7003A





## I/O definition

### Camera power

The Prosilica GB camera family has recently been updated to offer an expanded input power voltage range. The camera serial number is used to differentiate between cameras that offer 5–16 VDC and those that offer 5–25 VDC.

#### Caution

SN: 02-22XXA, 5–16 V. 12 V nominal.

SN: 02-22XXB, 5–25 V. 12 V nominal.



#### Note

A 12 V power adapter with camera connector is available for purchase from AVT:



- AVT P/N: 02-8007A North America Supply.
- AVT P/N: 02-8008A Universal Supply.

### Isolated IO ground

The **Isolated IO GND** connection provides the user ground reference and return path for **In 1**, and **Out 1**. It is recommended that the ground wiring be physically close to the **In/Out** wiring to prevent parasitic coupling. For example, a good cable design connects **In 1** to one conductor of a twisted pair, **Isolated IO GND** to the second conductor of the same twisted pair.

### RxD RS-232 and TxD RS-232

These signals are RS-232 compatible. These signals allow communication from the host system via the Ethernet port to a peripheral device connected to the camera. These signals are not isolated; therefore, careful attention should be used when designing cabling in noisy environments.

#### www

For complete RS-232 description and usage, see:



[http://www.alliedvisiontec.com/fileadmin/content/PDF/Support/Application\\_Notes/AplNote\\_-\\_RS-232\\_AVT\\_GigE.pdf](http://www.alliedvisiontec.com/fileadmin/content/PDF/Support/Application_Notes/AplNote_-_RS-232_AVT_GigE.pdf)

## Input triggers

Input triggers allow the camera to be synchronized to an external event. The camera can be programmed to trigger on the rising edge, falling edge, both edges, or level of the signal. The camera can also be programmed to capture an image at some programmable delay time after the trigger event.

### In 1 – opto-isolated

**In 1** is optically isolated and can be used in electrically noisy environments to prevent false trigger events. Tie **Camera GND** to **Isolated IO GND** to complete the trigger circuit. Compared to the non-isolated trigger, **In 1** has a longer propagation time. It can be driven from **5 to 24 V** with a **minimum current source of 10 mA**. See [Camera I/O opto-isolated user circuit example](#) for more information.

### In 2 – non-isolated

**In 2** is non-isolated and can be used when a faster trigger is required and when environmental noise is inconsequential. The required signal is **low voltage TTL 3.3 V**. Tie **Signal GND** to **Camera GND** to complete the trigger circuit. See [Camera I/O non-isolated user circuit example](#) for more wiring information.

**Caution** Do not exceed 5.5 V on signal inputs unless otherwise indicated



## Output signals

Output signals can be assigned to a variety of internal camera signals via software. They can be configured to active high or active low. The internal camera signals are listed as follows:

<i>Exposing</i>	Corresponds to when camera is integrating light
<i>Trigger Ready</i>	Indicates when the camera is ready to accept a trigger signal
<i>Trigger Input</i>	A relay of the trigger input signal used to “daisy chain” the trigger signal for multiple cameras
<i>Readout</i>	Valid when camera is reading out data
<i>Imaging</i>	Valid when camera is exposing or reading out
<i>Strobe</i>	Programmable pulse based on one of the above events
<i>GPO</i>	User programmable binary output

### **Out 1 – opto-isolated**

Out 1 is optically isolated and should be used in noisy environments. Out 1 requires a pull up resistor of greater than 1 K $\Omega$  to the user's 5 V logic supply. Tie **Camera GND** to **Isolated IO GND** to complete the external circuit. See [Camera I/O opto-isolated user circuit example](#) for more information.

### **Out 2– non-isolated**

**Out 2** signal is not electrically isolated and can be used when environmental electrical noise is inconsequential and faster trigger response is required. Use **Signal GND** to complete the external circuit. The output signal is a **low voltage TTL, maximum 3.3 V. Not suitable for driving loads in excess of 24 mA.** See [Camera I/O non-isolated user circuit example](#) for more wiring information.

### **Signal ground**

**Signal Ground** must be connected to the user's external circuit ground if **In 2** or **Out 2** is to be used, or if the RS-232 port is to be used. Note that **Signal Ground** is common with **Camera GND**; however, it is good practice to provide a separate ground connection for power and signal.

### **Video iris**

This signal can be used to drive the video input of a video iris lens. See [Video iris user circuit example](#) section for wiring information.

### **Reserved**

These signals are reserved for future use and should be left disconnected.

# Camera I/O opto-isolated user circuit example

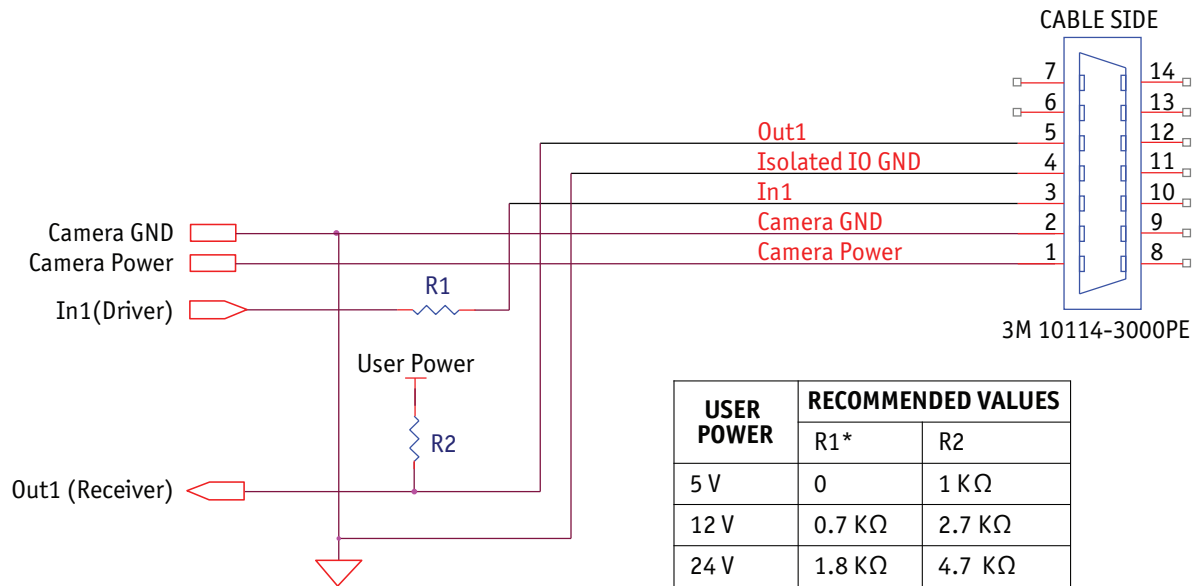

Figure 19: Prosilica GB isolated trigger user circuit

\* Cameras with SN: 02-XXXXX-0XXXX, R1 necessary for input greater than 5 V, see table above. Cameras with SN: 02-XXXXX-1XXXX, no R1 is necessary, 5–24 V.

**Caution**



**Input:** Incoming trigger must be able to source 10 mA.

**Output:** User power, with pull-up resistor R2 is required.

Isolated output is connected to the open collector of Fairchild MOCD207. The corresponding transistor emitter is connected to isolated ground. See the Fairchild MOCD207 datasheet for more detailed information.

## Camera I/O non-isolated user circuit example

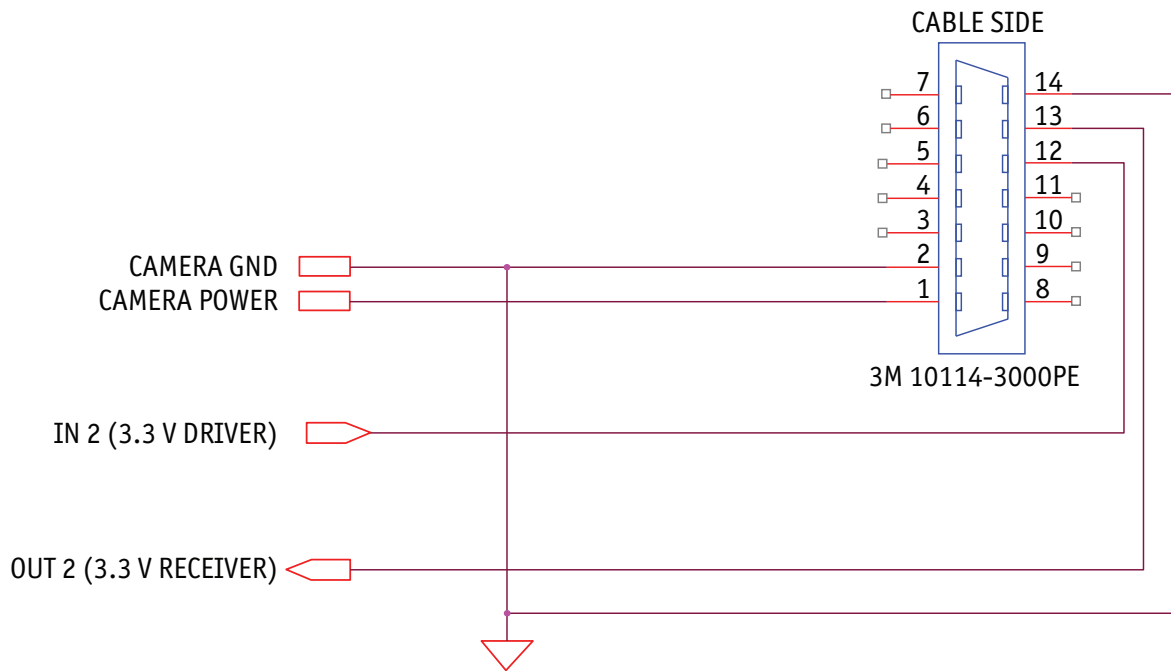

Figure 20: Prosilica GB non-isolated trigger user circuit

**Caution**



**Input:** Incoming trigger must be able to source 10  $\mu$ A, at 3.3 V. Input trigger voltage greater than 5.5 V will damage the camera.

**Output:** The maximum sync output current is 24 mA, at 3.3 V.

The non-isolated trigger circuit is connected to a Texas Instruments SN74LVC2G241 buffer/driver inside the camera. See the Texas Instruments SN74LVC2G241 for more detailed information.

## Video iris user circuit example

Prosilica GB series cameras provide built-in auto iris controls for controlling video-type auto-iris lenses. These lenses are available from many popular security lens companies including Pentax, Fujinon, Tamron, Schneider and others. Remote iris lens control allows the camera to be more adaptable to changing light conditions. It allows the user to manually control the exposure and gain values and rely solely on the auto iris for adjustment to ambient lighting.

**Caution**



The following schematic uses CAMERA POWER to power the video iris lens, and assumes CAMERA POWER = 12 V. Most video iris lenses operate at a 8–16 V input voltage. **Therefore, this circuit is not appropriate if using a 24 V camera power supply. Doing so may irreparably damage your lens.** Please consult your video iris lens specifications for the appropriate drive voltage.

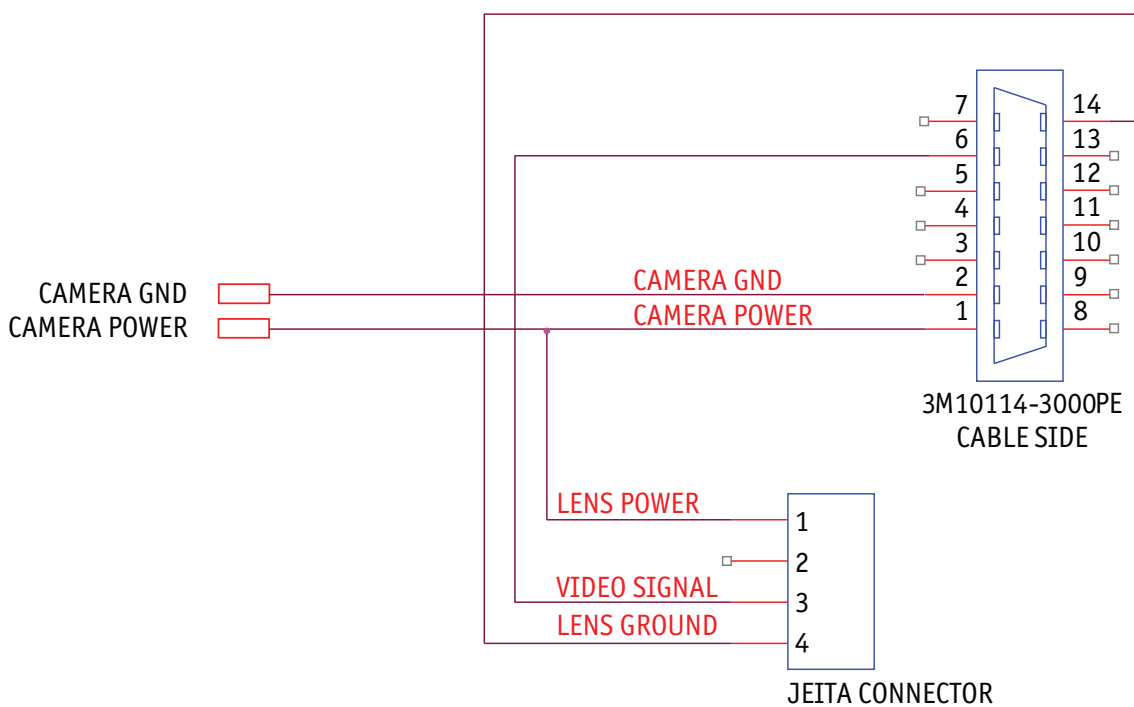

Figure 21: Prosilica GB video iris user circuit diagram

## Trigger timing diagram

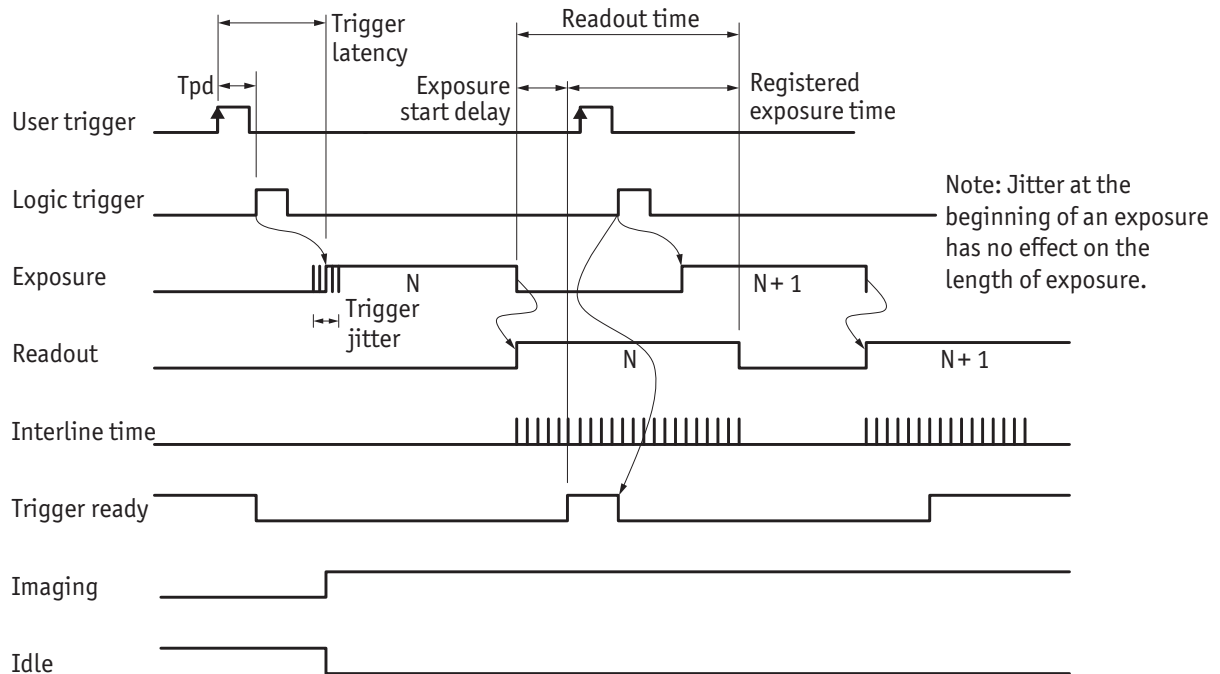

Figure 22: Prosilica GB internal signal timing waveforms

### Notes on triggering

Term	Definition
User trigger	Trigger signal applied by the user (hardware trigger, software trigger)
Logic trigger	Trigger signal seen by the camera internal logic (not visible to the user)
$T_{pd}$	Propagation delay between the user trigger and the logic trigger
Exposure	High when the camera image sensor is integrating light
Readout	High when the camera image sensor is reading out data
Trigger latency	Time delay between the user trigger and the start of exposure
Trigger jitter	Error in the trigger latency time

Table 12: Explanation of signals in timing diagram

Term	Definition
Trigger ready	Indicates to the user that the camera will accept the next trigger.
Registered exposure time	Exposure time value currently stored in the camera memory
Exposure start delay	Registered exposure time subtracted from the readout time and indicates when the next exposure cycle can begin such that the exposure will end after the current readout
Interline time	Time between sensor row readout cycles
Imaging	High when the camera image sensor is either exposing and/or reading out data
Idle	High if the camera image sensor is not exposing and/or reading out data

Table 12: Explanation of signals in timing diagram

### Trigger rules

**Note** The **user trigger pulse width** should be at least three times the width of the trigger latency as indicated in [Chapter Specifications](#) on page 12.



- The **end of exposure** will always trigger the next readout.
- The **end of exposure** must always end after the current readout.
- The **start of exposure** must always correspond with the interline time if readout is true.
- **Exposure start delay** equals the readout time minus the registered exposure time.

### Triggering during the idle state

For applications requiring the shortest possible *Trigger Latency* and the smallest possible *Trigger Jitter* the *User Trigger* signal should be applied when *Imaging* is false and *Idle* is true. In this case, *Trigger Latency* and *Trigger Jitter* are as indicated in the camera specifications.

### Triggering during the readout state

For applications requiring the fastest triggering cycle time whereby the camera image sensor is exposing and reading out simultaneously, apply the *User Trigger* signal as soon as a valid *Trigger Ready* is detected. In this case, *Trigger Latency* and *Trigger Jitter* can be up to 1 row time since *Exposure* must always begin on an *Interline* boundary.



## Firmware update

Firmware updates are carried out via the GigE connection. AVT provides an application for all Prosilica GB cameras that loads firmware to the camera using a simple interface. New feature introductions and product improvements motivate new firmware releases. All users are encouraged to use the newest firmware available and complete the firmware update if necessary.

**www**



Download the latest GigE firmware loader from the AVT website:

<http://www.alliedvisiontec.com/us/support/downloads/firmware.html>

**www**



For more information on GigE firmware update:

[http://www.alliedvisiontec.com/fileadmin/content/PDF/Support/Application\\_Notes/AppNote\\_-\\_GigE\\_Firmware\\_Update.pdf](http://www.alliedvisiontec.com/fileadmin/content/PDF/Support/Application_Notes/AppNote_-_GigE_Firmware_Update.pdf)

## Resolution and ROI frame rates

This section charts the resulting frame rate from changing sensor region of interest (ROI), from full image to a single line.

### Note



- Frame rate data was generated using **StreamBytesPerSecond = 124 MB/s** and an 8 bit pixel format such as Mono8 or BayerRG8. Frame rates may be lower if using network hardware incapable of 124 MB/s.
- The camera frame rate can be increased by reducing the camera's Height attribute, resulting in a decreased region of interest (ROI) or "window".
- The camera frame rate can also be increased by increasing the camera's BinningY attribute, resulting in a vertically scaled image (less overall height with same field of view).
- There is no frame rate increase with reduced width.

## Prosilica GB650

$$\text{Frame rate} = \frac{1}{14.39 \mu\text{s} \times \text{Height} + 1114.28 \mu\text{s}}$$

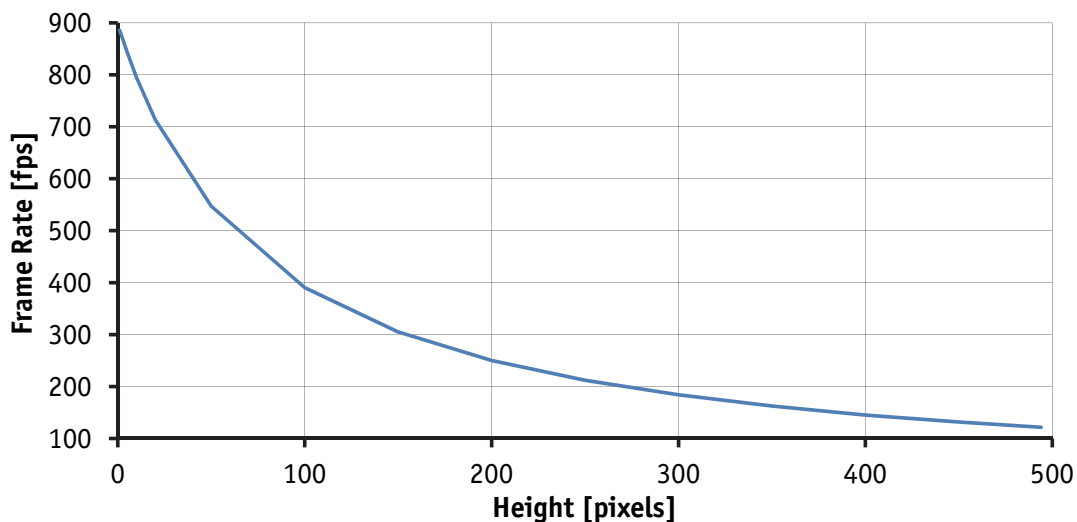

Figure 23: Frame rate vs. height for Prosilica GB650

## Prosilica GB660

$$\text{Frame rate} = \frac{1}{13.26 \mu\text{s} \times \text{Height} + 1844.78 \mu\text{s}}$$

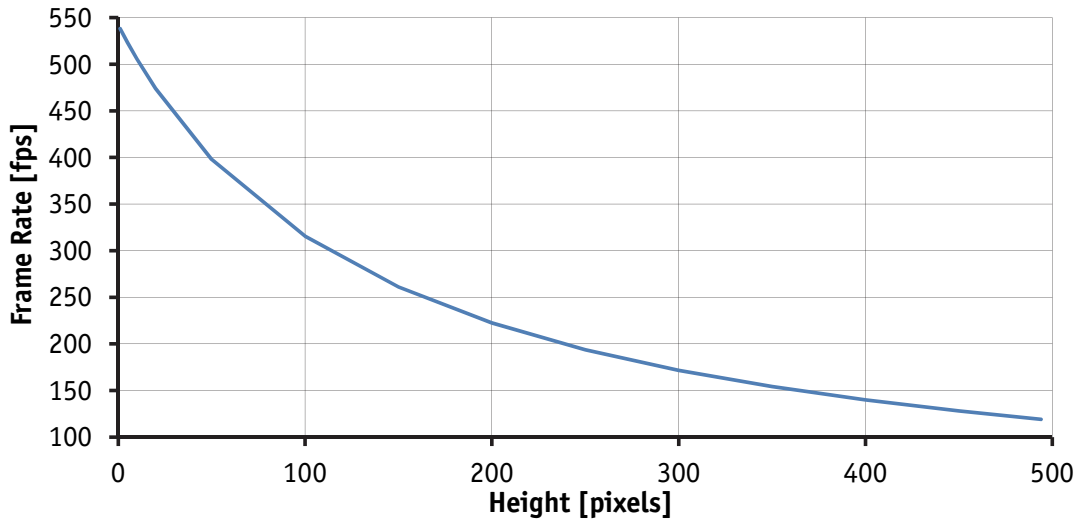

Figure 24: Frame rate vs. height for Prosilica GB660

## Prosilica GB1380

$$\text{Frame rate} = \frac{1}{27.79 \mu\text{s} \times \text{Height} + 4881.40 \mu\text{s}}$$

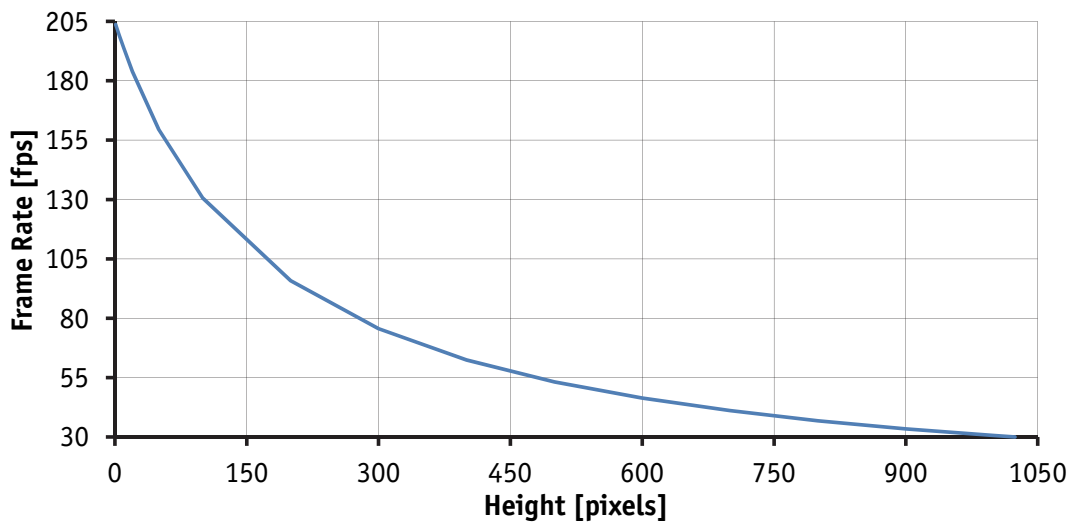

Figure 25: Frame rate vs. height for Prosilica GB1380

## Prosilica GB2450

$$\text{Frame rate} = \frac{1}{26.63 \mu\text{s} \times \text{Height} + 12079.91 \mu\text{s}}$$

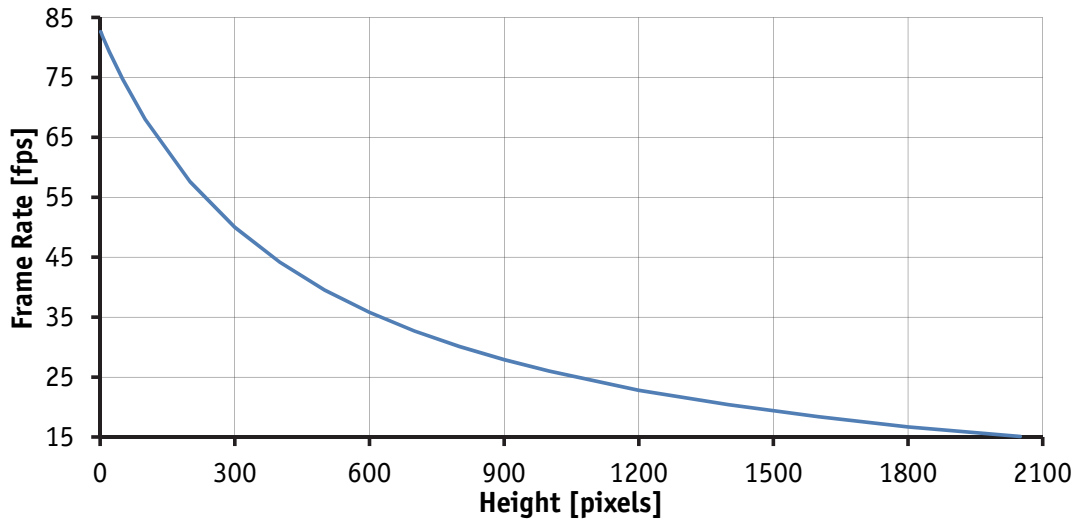

Figure 26: Frame rate vs. height for Prosilica GB2450

## Prosilica GB model comparison

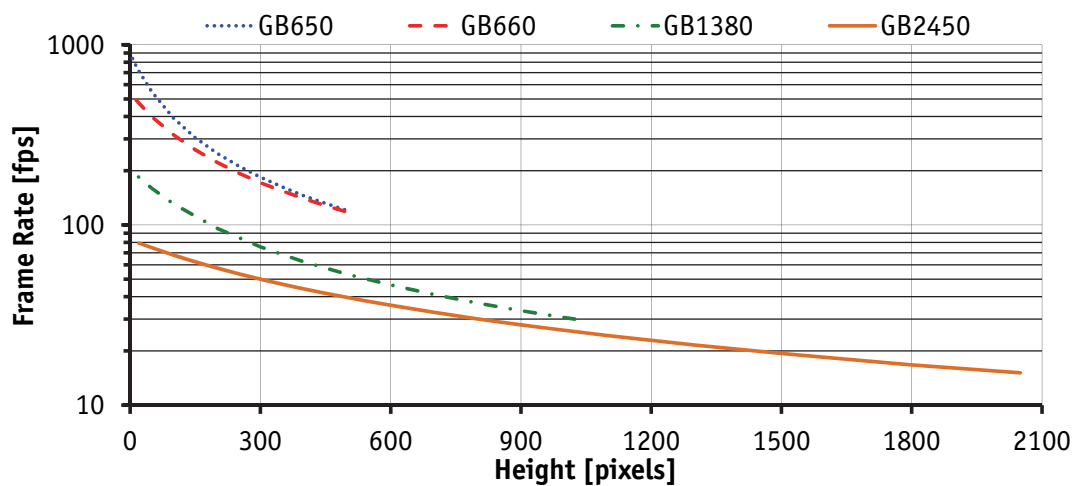

Figure 27: Maximum frame rate comparison for select models

# Description of the data path

The following diagrams illustrate the data flow and the bit resolution of image data. The individual blocks are described in more detail in the **AVT GigE Camera and Driver Features** document.

## Prosilica GB: monochrome cameras

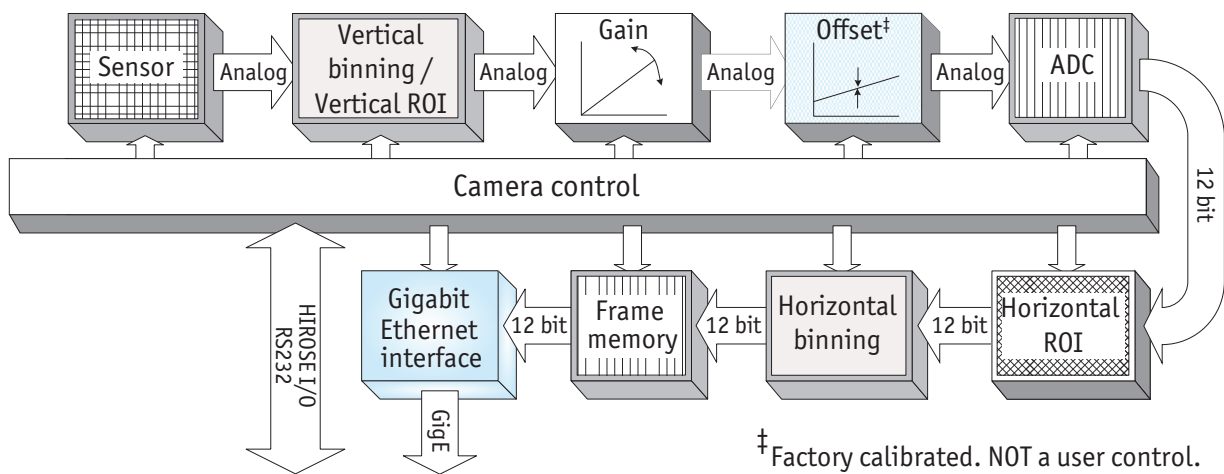

Figure 28: Block diagram of monochrome Prosilica GB cameras

## Prosilica GB: color cameras

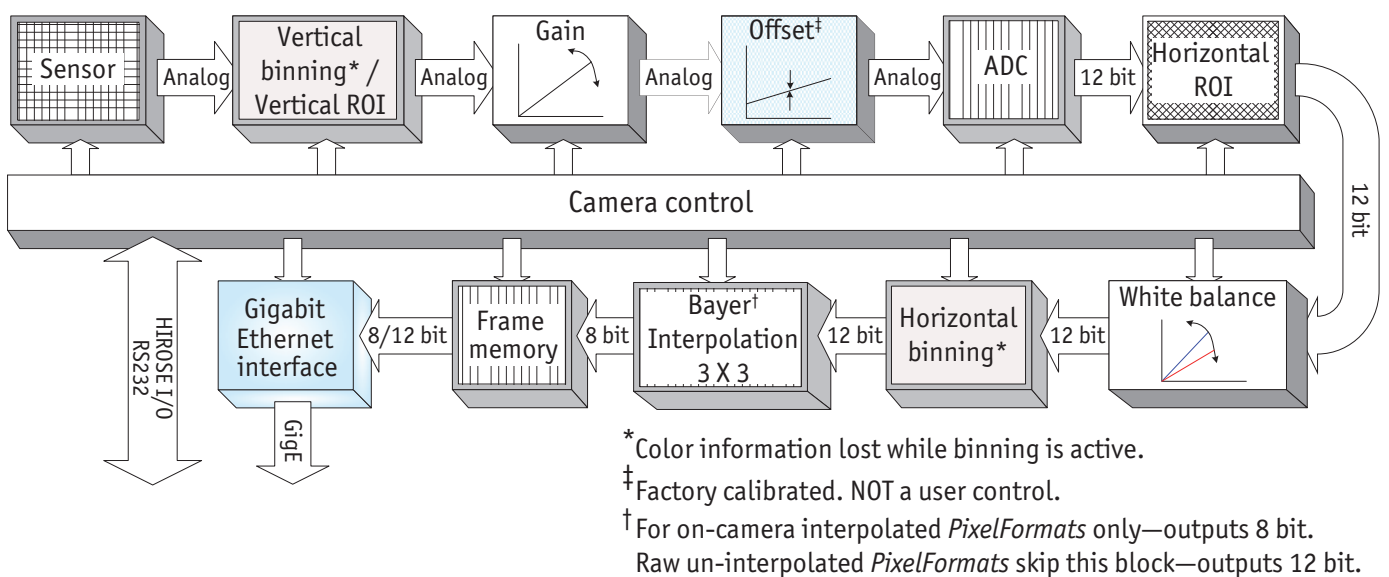

Figure 29: Block diagram of color Prosilica GB cameras

---

## Additional references

### **Prosilica GB webpage**

<http://www.alliedvisiontec.com/us/products/cameras/gigabit-ethernet/prosilica-gb.html>

### **Prosilica GB Documentation**

<http://www.alliedvisiontec.com/us/support/downloads/product-literature/prosilica-gb.html>

### **AVT VIMBA SDK**

<http://www.alliedvisiontec.com/us/products/software/vimba-sdk.html>

### **AVT GigE PvAPI SDK**

<http://www.alliedvisiontec.com/us/products/legacy.html>

### **AVT Knowledge Base**

<http://www.alliedvisiontec.com/us/support/knowledge-base.html>

### **AVT Case Studies**

<http://www.alliedvisiontec.com/us/products/applications/industrial-inspection.html>

### **Prosilica GB Firmware**

<http://www.alliedvisiontec.com/us/support/downloads/firmware.html>

# Index

## A

Adjustment of C-Mount ..... 29

## B

Block diagram

    Prosilica GB color cameras ..... 45

    Prosilica GB monochrome cameras..... 45

## C

Camera dimensions ..... 22

Camera GND..... 32, 34, 35

Camera interfaces ..... 30

Camera Power ..... 32, 33

CE..... 11, 12, 14, 16, 18

Cleaning optics ..... 9

Connector orientation ..... 22

Copyright..... 2

## D

Data path..... 45

Declaration of conformity..... 11

Document history ..... 6

## E

Environmental specifications ..... 8

Exposing (trigger) ..... 40

Exposure (definition) ..... 39

exposure cycle (trigger)..... 40

Exposure start delay (signal) ..... 40

## F

FCC Class A ..... 11, 12, 14, 18

## G

GND for ext. power ..... 32

## I

Idle (signal) ..... 40

Imaging (signal) ..... 40

Input triggers

    In 1..... 32, 33, 34

    In 2..... 32, 34, 35

Integrating light (trigger)..... 39

Interline boundary ..... 40

Interline time (signal)..... 40

Isolated IO GND..... 32, 33, 34, 35

## L

Legal notice ..... 2

Logic trigger (definition) ..... 39

## M

Mechanical drawing

    Camera lens mount..... 27

    Landscape sensor and inline connector ... 23

    Landscape sensor and vertical connector . 24

    Portrait sensor and inline connector ..... 25

    Portrait sensor and vertical connector ..... 26

Multicast ..... 20

## O

Optical flange focal distance..... 28

Output signals

    Out 1 ..... 32, 33, 35

    Out 2 ..... 32, 35

## P

Precautions ..... 8

Propagation delay (trigger) ..... 39

## R

Reading out data (trigger)..... 40

readout (definition) ..... 39

Readout data (trigger)..... 39

Region of interest..... 20, 42

Registered exposure time (signal) ..... 40

Resolution and ROI frame rates

    Model comparison ..... 44

    Prosilica GB1380..... 43

    Prosilica GB2450..... 44

    Prosilica GB650 ..... 42

    Prosilica GB660 ..... 43

RoHS (2011/65/EU) .....	11, 12, 14, 16, 18
RS-232 .....	32, 33

## S

Sensor row readout cycles .....	40
Signal GND .....	32, 34, 35
Specifications .....	12
Spectral sensitivity	
Prosilica GB1380 .....	17
Prosilica GB1380C .....	17
Prosilica GB2450 .....	19
Prosilica GB2450C .....	19
Prosilica GB650 .....	13
Prosilica GB650C .....	13
Prosilica GB660 .....	15
Prosilica GB660C .....	15
Spectral transmission	
IRC30 filter .....	21
Status LEDs .....	30
StreamBytesPerSecond .....	42
Styles .....	7
Symbols .....	7

## T

Time delay (trigger) .....	39
Tpd (definition) .....	39
Trademarks .....	2
Trigger jitter (definition) .....	39
Trigger latency (definition) .....	39
trigger latency time .....	39
Trigger ready (signal) .....	40
Trigger rules .....	40
Trigger timing diagram .....	39

## U

User trigger (definition) .....	39
---------------------------------	----

## V

Video iris .....	32, 35
------------------	--------

## W

Warranty .....	2
----------------	---