

AVT Guppy PRO



Technical Manual

V4.0.0

23 July 2012

Legal notice

For customers in the U.S.A.

This equipment has been tested and found to comply with the limits for a Class B digital device, pursuant to Part 15 of the FCC Rules. These limits are designed to provide reasonable protection against harmful interference when the equipment is operated in a residential environment. This equipment generates, uses, and can radiate radio frequency energy and, if not installed and used in accordance with the instruction manual, may cause harmful interference to radio communications. However there is no guarantee that interferences will not occur in a particular installation. If the equipment does cause harmful interference to radio or television reception, the user is encouraged to try to correct the interference by one or more of the following measures:

- Reorient or relocate the receiving antenna.
- Increase the distance between the equipment and the receiver.
- Use a different line outlet for the receiver.
- Consult a radio or TV technician for help.

You are cautioned that any changes or modifications not expressly approved in this manual could void your authority to operate this equipment. The shielded interface cable recommended in this manual must be used with this equipment in order to comply with the limits for a computing device pursuant to Subpart B of Part 15 of FCC Rules.

For customers in Canada

This apparatus complies with the Class B limits for radio noise emissions set out in the Radio Interference Regulations.

Pour utilisateurs au Canada

Cet appareil est conforme aux normes classe B pour bruits radioélectriques, spécifiées dans le Règlement sur le brouillage radioélectrique.

Life support applications

These products are not designed for use in life support appliances, devices, or systems where malfunction of these products can reasonably be expected to result in personal injury. Allied customers using or selling these products for use in such applications do so at their own risk and agree to fully indemnify Allied for any damages resulting from such improper use or sale.

Trademarks

Microsoft, Windows, Windows 7, Windows Vista, and Windows XP are either registered trademarks or trademarks of Microsoft Corporation in the United States and/or other countries.

FireWire is a registered trademark of Apple Computers for the IEEE 1394 standard.

IEEE 1394 standard is a trademark of the Institute of Electrical and Electronics Engineers, Inc. and licensed to the IEEE 1394 Standards Association.

Apple is a trademark of Apple Inc., registered in the U.S. and other countries.

Unless stated otherwise, all trademarks appearing in this document of Allied Vision Technologies are brands protected by law.

Warranty

The information provided by Allied Vision Technologies is supplied without any guarantees or warranty whatsoever, be it specific or implicit. Also excluded are all implicit warranties concerning the negotiability, the suitability for specific applications or the non-breaking of laws and patents. Even if we assume that the information supplied to us is accurate, errors and inaccuracy may still occur.

Copyright

All texts, pictures and graphics are protected by copyright and other laws protecting intellectual property. It is not permitted to copy or modify them for trade use or transfer, nor may they be used on web sites.

Allied Vision Technologies GmbH 07/2012

All rights reserved.

Managing Director: Mr. Frank Grube

Tax ID: DE 184383113

Headquarters:

Taschenweg 2A

D-07646 Stadtroda, Germany

Tel.: +49 (0)36428 6770

Fax: +49 (0)36428 677-28

e-mail: info@alliedvisiontec.com

Contents

Contacting Allied Vision Technologies	9
Introduction	10
Document history	10
Manual overview	17
Conventions used in this manual.....	18
Styles	18
Symbols	18
More information.....	19
Before operation	20
Guppy PRO cameras	21
Conformity	22
FireWire	23
Overview	23
Definition	23
IEEE 1394 standards	23
Why use FireWire?	23
FireWire in detail.....	24
Serial bus.....	24
FireWire connection capabilities	25
Capabilities of 1394a (FireWire 400).....	26
IIDC V1.3 camera control standards	26
Capabilities of 1394b (FireWire 800)	26
IIDC V1.31 camera control standards	27
Compatibility between 1394a and 1394b.....	27
Compatibility example	27
Image transfer via 1394a and 1394b	28
1394b bandwidths.....	29
Requirements for PC and 1394b.....	29
Requirements for laptop and 1394b	30
Example 1: 1394b bandwidth of Guppy PRO cameras.....	31
Example 2: More than one Guppy PRO camera at full speed	31
FireWire Plug & play capabilities.....	32
FireWire hot-plug and screw-lock precautions	32
Operating system support.....	33
Filter and lenses	34
IR cut filter: spectral transmission	34
Camera lenses	35
Specifications	38
Guppy PRO F-031B/C.....	38

Guppy PRO F-032B/C	40
Guppy PRO F-033B/C	42
Guppy PRO F-046B/C	44
Guppy PRO F-095C	46
Guppy PRO F-125B/C	48
Guppy PRO F-146B/C	50
Guppy PRO F-201B/C	52
Guppy PRO F-503B/C	54
Spectral sensitivity	56
Camera dimensions	66
Guppy PRO standard housing (1 x 1394b copper)	66
Tripod adapter	67
Cross section: C-Mount	68
Adjustment of C-Mount	69
Camera interfaces	70
IEEE 1394b port pin assignment	70
Camera I/O connector pin assignment	71
Status LEDs	72
Normal conditions	73
Error conditions	73
Control and video data signals	75
Inputs	75
Triggers	75
Input/output pin control	76
IO_INP_CTRL 1	77
Trigger delay	78
Outputs	80
IO_OUTP_CTRL 1-3	82
Output modes	83
Pulse-width modulation	85
PWM: minimal and maximal periods and frequencies	86
PWM: Examples in practice	87
Pixel data	88
Description of video data formats	89
Description of the data path	94
Block diagrams of the cameras	94
Black and white cameras	94
Color cameras	95
White balance	96
One-push white balance	98
Auto white balance (AWB)	100
Auto shutter	101
Auto gain	103
Manual gain	106
Brightness (black level or offset)	106

Mirror function (only Guppy PRO F-503)	108
Look-up table (LUT) and gamma function	109
Loading an LUT into the camera	111
Defect pixel correction	
(only Guppy PRO F-503B/C).....	112
Building defect pixel data	114
Grab an image with defect pixel data	115
Calculate defect pixel coordinates	115
Reset values (resolution, shutter, gain, brightness)	115
Activate/deactivate defect pixel correction	116
Store defect pixel data non-volatile	116
Load non-volatile stored defect pixel data	116
Send defect pixel data to the host.....	116
Receive defect pixel data from the host.....	116
Binning (only b/w cameras; F-503: also color cameras)	117
2 x binning (F-503 also 4 x)	117
Vertical binning	118
Horizontal binning	121
2 x full binning (F-503 also 4 x full binning)	123
Sub-sampling (only F-503B/C and CCD cameras b/w).....	125
What is sub-sampling?	125
Which Guppy PRO models have sub-sampling?	125
Description of sub-sampling.....	125
Binning and sub-sampling access (F-503 only).....	130
Packed 12-Bit Mode	133
Color interpolation (BAYER demosaicing)	134
Hue and saturation	135
Color correction.....	136
Why color correction?	136
Color correction in AVT cameras	136
Color correction: formula.....	136
GretagMacbeth ColorChecker	136
Changing color correction coefficients	137
Switch color correction on/off	137
Color conversion (RGB to YUV).....	138
Bulk Trigger	138
Level Trigger.....	138
Controlling image capture	139
Global shutter (CCD cameras only).....	139
Electronic rolling shutter (ERS) and global reset release shutter (GRR) (only Guppy PRO F-503)	140
Trigger modes	141
Trigger_Mode_0 (edge mode) and Trigger_Mode_1 (level mode).....	142
Guppy PRO F-503, Trigger_Mode_0, electronic rolling shutter	143
Guppy PRO F-503, Trigger_Mode_0, global reset release shutter	145
Bulk trigger (Trigger_Mode_15)	146
Trigger delay	149
Trigger delay advanced register.....	150

Software trigger	151
Debounce.....	151
Debounce time.....	152
Exposure time (shutter) and offset.....	153
Exposure time of Guppy PRO F-503 (CMOS).....	153
Exposure time offset.....	154
Minimum exposure time	154
Example: Guppy PRO F-031	155
Extended shutter.....	155
One-shot	156
One-shot command on the bus to start of exposure	157
End of exposure to first packet on the bus	158
Multi-shot	159
ISO_Enable / free-run.....	159
Asynchronous broadcast	159
Jitter at start of exposure	160
Video formats, modes and bandwidth	162
Guppy PRO F-031B / Guppy PRO F-031C.....	163
Guppy PRO F-032B / Guppy PRO F-032C.....	165
Guppy PRO F-033B / Guppy PRO F-033C.....	167
Guppy PRO F-046B / Guppy PRO F-046C.....	169
Guppy PRO F-095C	171
Guppy PRO F-125B / Guppy PRO F-125C.....	173
Guppy PRO F-146B / Guppy PRO F-146C.....	175
Guppy PRO F-201B / Guppy PRO F-201C.....	177
Guppy PRO F-503B / Guppy PRO F-503C.....	179
Area of interest (AOI)	181
Autofunction AOI.....	183
Frame rates.....	184
Frame rates Format_7	188
Guppy PRO F-031: AOI frame rates	189
Guppy PRO F-032: AOI frame rates	190
Guppy PRO F-033: AOI frame rates	191
Guppy PRO F-046: AOI frame rates	192
Guppy PRO F-095: AOI frame rates	193
Guppy PRO F-125: AOI frame rates	194
Guppy PRO F-146: AOI frame rates	195
Guppy PRO F-201: AOI frame rates	196
Guppy PRO F-503: AOI frame rates	197
How does bandwidth affect the frame rate?	199
Example formula for the b/w camera.....	200
Test images	201
Loading test images	201
Test images for b/w cameras.....	201
Test images for color cameras	202
YUV4:2:2 mode.....	202
Mono8 (raw data)	202

Configuration of the camera	203
Camera_Status_Register.....	203
Example.....	204
Sample program.....	206
Example FireGrab.....	206
Example FireStack API.....	207
Configuration ROM.....	208
Implemented registers (IIDC V1.31).....	211
Camera initialize register.....	211
Inquiry register for video format.....	211
Inquiry register for video mode.....	212
Inquiry register for video frame rate and base address.....	213
Inquiry register for basic function.....	222
Inquiry register for feature presence.....	223
Inquiry register for feature elements.....	225
Status and control registers for camera.....	228
Inquiry register for absolute value CSR offset address.....	229
Status and control register for one-push.....	230
Feature control error status register.....	233
Video mode control and status registers for Format_7.....	234
Quadlet offset Format_7 Mode_0.....	234
Quadlet offset Format_7 Mode_1.....	234
Format_7 control and status register (CSR).....	234
Advanced features (AVT-specific).....	236
Advanced registers summary.....	236
Extended version information register.....	238
Advanced feature inquiry.....	241
Camera status.....	243
Maximum resolution.....	244
Time base.....	244
Extended shutter.....	246
Test images.....	247
Look-up tables (LUT).....	248
Loading a look-up table into the camera.....	249
Defect pixel correction.....	250
Input/output pin control.....	252
Delayed Integration Enable (IntEna).....	253
Auto shutter control.....	254
Auto gain control.....	255
Autofunction AOI.....	256
Color correction.....	257
Trigger delay.....	258
Mirror image.....	258
Soft reset.....	259
Maximum ISO packet size.....	260
Format_7 mode mapping	
(only Guppy PRO F-503).....	262
Example.....	263
Low-noise binning mode (2 x and 4 x binning)	

(only Guppy PRO F-503)	263
Software feature control (disable LED).....	264
Disable LEDs.....	264
User profiles.....	265
Error codes	266
Reset of error codes	267
Stored settings.....	267
Pulse-width modulation (PWM).....	268
Global reset release shutter (only Guppy PRO F-503)	268
Gpdata_BUFFER.....	269
Little endian vs. big endian byte order.....	269
Firmware update	271
Extended version number (FPGA/μC).....	271
Appendix	272
Sensor position accuracy of AVT Guppy PRO cameras	272
Index	273

Contacting Allied Vision Technologies

Info



- **Technical information:**
<http://www.alliedvisiontec.com>
- **Support:**
support@alliedvisiontec.com

Allied Vision Technologies GmbH (Headquarters)

Taschenweg 2a
07646 Stadtroda, Germany
Tel.: +49 36428-677-0
Fax.: +49 36428-677-28
e-mail: info@alliedvisiontec.com

Allied Vision Technologies Canada Inc.

101-3750 North Fraser Way
Burnaby, BC, V5J 5E9, Canada
Tel: +1 604-875-8855
Fax: +1 604-875-8856
e-mail: info@alliedvisiontec.com

Allied Vision Technologies Inc.

38 Washington Street
Newburyport, MA 01950, USA
Toll Free number +1-877-USA-1394
Tel.: +1 978-225-2030
Fax: +1 978-225-2029
e-mail: info@alliedvisiontec.com

Allied Vision Technologies Asia Pte. Ltd.

82 Playfair Road
#07-02 D'Lithium
Singapore 368001
Tel: +65 6634-9027
Fax: +65 6634-902
e-mail: info@alliedvisiontec.com

Introduction

This **AVT Guppy PRO Technical Manual** describes in depth the technical specifications, dimensions, all camera features (IIDC standard and AVT smart features) and their registers, trigger features, all video and color formats, bandwidth and frame rate calculation.

For information on hardware installation, safety warnings, pin assignments on I/O connectors and 1394b connectors read the **Hardware Installation Guide**.

Note Please read through this manual carefully.



We assume that you have read already the **Hardware Installation Guide** and that you have installed the hardware and software on your PC or laptop (FireWire card, cables).

Document history

Version	Date	Remarks
V2.0.1	30.11.10	New Manual — RELEASE status
to be continued on next page		

Table 1: Document history

Version	Date	Remarks
continued from last page		
V2.0.2	05.04.11	<ul style="list-style-type: none"> • Revised video formats of Guppy PRO F-503 Table 85: Video Format_7 default modes Guppy PRO F-503B / F-503C on page 180 • Added exposure time offset for Guppy PRO F-503 Table 61: Camera-specific exposure time offset on page 154 • Added <i>On request: power out 6 W (HIROSE)</i> in all specification tables: see Chapter Specifications on page 38 to 55 • Revised advanced register: input control (only one input) in Table 23: Advanced register: Input control on page 76 • Revised IO_INP_CTRL: ID 0x3..0x1F is Reserved in Table 24: Input routing on page 77 • Revised advanced register: output control (3 outputs) in Table 29: Advanced register: Output control on page 82 • At register 0xF1000200 changed width and height: see Table 126: Advanced register: Maximum resolution inquiry on page 244 • YUV8: deleted description of data type <i>straight binary</i>: Figure 35: Data structure of YUV8; Source: IIDC V1.31 on page 92 • Y (Mono8/Raw8) are AVT own formats: see Table 36: Y (Mono8) format: Source: IIDC V1.31 / Y (Raw8) format: AVT on page 90
to be continued on next page		

Table 1: Document history

Version	Date	Remarks
continued from last page		
[continued] V2.0.2	[continued] 05.04.11	<ul style="list-style-type: none"> • Video data formats now with subscript letters instead of underscore as wrongly used in IIDC, see Chapter Description of video data formats on page 89 • Revised spectral sensitivity for Guppy PRO F-031C: see Figure 8: Spectral sensitivity of Guppy PRO F-031C (without IR cut filter) on page 57 • Defect pixel correction: you don't need to set value for brightness to max. any more: see Figure 46: Defect pixel correction: build and store on page 114 and Chapter Grab an image with defect pixel data on page 115 • Max. resolution of Guppy PRO F-503B/C changed from 2592 x 1944 to 2588 x 1940: see Chapter Guppy PRO F-503B/C on page 54 and Chapter Video Format_7 default modes Guppy PRO F-503B / F-503C on page 180 • Added Guppy PRO F-503 frame rate and bandwidth: see Table 4: Bandwidth of Guppy PRO cameras on page 31 • Changed max. resolution of Guppy PRO F-503 from 2592 x 1944 to 2588 x 1940: see Chapter Guppy PRO F-503B/C on page 54 • Guppy PRO F-503: Mono8, YUV411 and YUV422 now in all F7 modes available: see Chapter Guppy PRO F-503B/C on page 54 • Guppy PRO F-503: added minimum exposure time in Table 62: Camera-specific minimum exposure time on page 154 • Guppy PRO F-503: added shutter speed at full resolution: see Chapter Guppy PRO F-503B/C on page 54 • Guppy PRO F-503: added shutter speed: see Chapter Guppy PRO F-503B/C on page 54 • Guppy PRO F-503: binning and sub-sampling in all F7 modes for b/w and color models: see Chapter Guppy PRO F-503B/C on page 54 • Guppy PRO F-503: added 800 Mbit/s: see Chapter Guppy PRO F-503B/C on page 54 • Guppy PRO F-503: added exposure time for long-term integration (extended shutter) up to 22 seconds: see Chapter Extended shutter on page 155 • Guppy PRO F-503: Revised chapter Chapter Mirror function (only Guppy PRO F-503) on page 108
to be continued on next page		

Table 1: Document history

Version	Date	Remarks
continued from last page		
[continued] V2.0.2	[continued] 05.04.11	<ul style="list-style-type: none"> Guppy PRO F-503: manual gain range now 8 ... 48 (instead of 60): see Chapter Manual gain on page 106 Guppy PRO F-503: manual gain range in dB now 0 ... 18 dB (instead of 26 dB): see Chapter Guppy PRO F-503B/C on page 54
V2.0.3	08.04.11	<ul style="list-style-type: none"> Revised Chapter Binning (only b/w cameras; F-503: also color cameras) on page 117
V3.0.2	18.05.12	<p>Changed effective min. exposure time of Guppy PRO F-031 (ICX618) from 27 μs to 75 μs:</p> <ul style="list-style-type: none"> Chapter Guppy PRO F-031B/C on page 38 Chapter Example: Guppy PRO F-031 on page 155 Chapter End of exposure to first packet on the bus on page 158 <p>Changed effective min. exposure time of Guppy PRO F-032 (ICX424) from 27 μs to 37 μs:</p> <ul style="list-style-type: none"> Chapter Guppy PRO F-032B/C on page 40 Changed frame rate from 79 fps to 82 fps Chapter Minimum exposure time on page 154 Chapter End of exposure to first packet on the bus on page 158 <p>Changed effective min. exposure time of Guppy PRO F-125 (ICX445) from 35 μs to 39 μs:</p> <ul style="list-style-type: none"> Chapter Guppy PRO F-125B/C on page 48 Chapter Minimum exposure time on page 154 Chapter End of exposure to first packet on the bus on page 158 <p>Changed effective min. exposure time of Guppy PRO F-146 (ICX267) from 35 μs to 45 μs:</p> <ul style="list-style-type: none"> Chapter Guppy PRO F-146B/C on page 50 Chapter Minimum exposure time on page 154 Chapter End of exposure to first packet on the bus on page 158 <p>Changed effective min. exposure time of Guppy PRO F-201 (ICX274) from 45 μs to 55 μs:</p> <ul style="list-style-type: none"> Chapter Guppy PRO F-201B/C on page 52 Chapter Minimum exposure time on page 154 Chapter End of exposure to first packet on the bus on page 158
to be continued on next page		

Table 1: Document history

Version	Date	Remarks
continued from last page		
[continued] V3.0.2	[continued] 18.05.12	<p>Some minor corrections:</p> <ul style="list-style-type: none"> • Guppy PRO cameras have 1 input / 3 outputs (not 2/4) in Chapter Pulse-width modulation on page 85 • Corrected frame rates of Guppy PRO F-031 (121 fps), F-032 (82 fps) and F-146 (17 fps) in Chapter Example 1: 1394b bandwidth of Guppy PRO cameras on page 31 • Guppy PRO F-201B, Format_2, Mode_5: also 7.5 fps possible: see Chapter Guppy PRO F-201B / Guppy PRO F-201C on page 177 <p>New sensors ICX414 and ICX415:</p> <ul style="list-style-type: none"> • Guppy PRO F-033 (ICX414): <ul style="list-style-type: none"> – Chapter Guppy PRO F-033B/C on page 42 – Figure 11: Spectral sensitivity of Guppy PRO F-033B on page 59 – Figure 12: Spectral sensitivity of Guppy PRO F-033C (without IR cut filter) on page 59 – New: Table 10: Focal length vs. field of view (Guppy PRO F-033/046/146) on page 37 – Chapter Video fixed formats Guppy PRO F-033B / Guppy PRO F-033C on page 167 – Chapter Video Format_7 default modes Guppy PRO F-033B / Guppy PRO F-033C on page 168 – Chapter Guppy PRO F-033: AOI frame rates on page 191 • Guppy PRO F-046 (ICX415): <ul style="list-style-type: none"> – Chapter Guppy PRO F-046B/C on page 44 – Figure 13: Spectral sensitivity of Guppy PRO F-046B on page 60 – Figure 14: Spectral sensitivity of Guppy PRO F-046C (without IR cut filter) on page 60 – New: Table 10: Focal length vs. field of view (Guppy PRO F-033/046/146) on page 37 – Chapter Video fixed formats Guppy PRO F-046B / Guppy PRO F-046C on page 169 – Chapter Video Format_7 default modes Guppy PRO F-046B / Guppy PRO F-046C on page 170 – Chapter Guppy PRO F-046: AOI frame rates on page 192
to be continued on next page		

Table 1: Document history

Version	Date	Remarks
continued from last page		
[continued] V3.0.2	[continued] 18.05.12	<p>Guppy PRO F-503:</p> <ul style="list-style-type: none"> F0M2 (120 fps), F0M5 (120 fps), F1M5 (60 fps) are only available with electronic rolling shutter (wheras present in both shutter modes). If using global reset release shutter the camera runs these modes with half frame rates only. See Chapter Guppy PRO F-503B / Guppy PRO F-503C on page 179. Changed range in dB and increment length: Table 45: Manual gain range of the various Guppy PRO types on page 106 <p>IR cut filter:</p> <ul style="list-style-type: none"> Changed IR cut filter to (<i>type Jenofilt 217</i>): see Figure 6: Approximate spectral transmission of IR cut filter (may vary slightly by filter lot) (type Hoya C5000) on page 34
V3.0.3	14.06.12	<p>New frame rates from development:</p> <p>Guppy PRO F-031</p> <ul style="list-style-type: none"> Guppy PRO F-031: 123 fps instead of 121 fps in F7M0, see Table 12: Specification Guppy PRO F-031B/C on page 38 Guppy PRO F-031: 564 fps instead of 563 fps (AOI height 10, Raw12), see Table 90: Frame rates (fps) of Guppy PRO F-031 as function of AOI height (pixel) [width=656] on page 189 Guppy PRO F-031: 188 fps instead of 199 fps (F7M2, Mono16), see Table 69: Video Format_7 default modes Guppy PRO F-031B / Guppy PRO F-031C on page 164 <p>Guppy PRO F-032</p> <ul style="list-style-type: none"> Guppy PRO F-032: F7M0 (Raw8/Raw12/Raw16/YUV411/YUV422/Mono8/Mono12/Mono16): 82 fps instead of 79 fps, see Table 71: Video Format_7 default modes Guppy PRO F-032B / Guppy PRO F-032C on page 166 <p>Guppy PRO F-033</p> <ul style="list-style-type: none"> Guppy PRO F-033: F7M0 (RGB8): 85 fps instead of 84 fps. F7M0 (RGB8): 67 fps instead of 66 fps. See Table 73: Video Format_7 default modes Guppy PRO F-033B / Guppy PRO F-033C on page 168 Guppy PRO F-033: 85 fps instead of 84 fps. See Chapter Guppy PRO F-033B/C on page 42
to be continued on next page		

Table 1: Document history

Version	Date	Remarks
continued from last page		
[continued] V3.0.3	[continued] 15.06.12	<p>Guppy PRO F-046</p> <ul style="list-style-type: none"> Guppy PRO F-046: 62 fps instead of 61 fps. See Chapter Guppy PRO F-046B/C on page 44 Guppy PRO F-046: F7M0 (Raw8/Raw12/Raw16/YUV411/YUV422/Mono8): 62 fps instead of 61 fps, see Table 75: Video Format_7 default modes Guppy PRO F-046B / Guppy PRO F-046C on page 170 <p>Guppy PRO F-125</p> <ul style="list-style-type: none"> Guppy PRO F-125: 31 fps instead of 30 fps. See Chapter Guppy PRO F-125B/C on page 48 <p>Guppy PRO F-146</p> <ul style="list-style-type: none"> Guppy PRO F-146: F7M0 (RGB8): 15 fps instead of 17 fps, see Table 81: Video Format_7 default modes Guppy PRO F-146B / F-146C on page 176 <p>Guppy PRO F-201</p> <ul style="list-style-type: none"> Guppy PRO F-201: F7M0 (RGB8): 12 fps instead of 10 fps, see Table 83: Video Format_7 default modes Guppy PRO F-201B / F-201C on page 178 Guppy PRO F-201: F7M0 (RGB8): 12 fps instead of 10 fps, see Table 97: Frame rates of Guppy PRO F-201 as function of AOI height [width=1624] on page 196

Table 1: Document history

Version	Date	Remarks
V4.0.0	23 July 2012	<p>Deleted Active FirePackage in Chapter Specifications on page 13 ff.</p> <p>New Guppy PRO F-095C</p> <ul style="list-style-type: none"> • Table 4: Bandwidth of Guppy PRO cameras on page 31 • Table 9: Focal length vs. field of view (Guppy PRO F-095) on page 36 • Chapter Guppy PRO F-095C on page 46 • Chapter Exposure time offset on page 154 • Chapter Minimum exposure time on page 154 • Chapter Jitter at exposure start (no binning, no sub-sampling) on page 161 • Chapter End of exposure to first packet on the bus on page 158 • Chapter Guppy PRO F-095C on page 171 • Chapter Guppy PRO F-095: AOI frame rates on page 193 • Figure 15: Spectral sensitivity of Guppy PRO F-095C (without IR cut filter) on page 61 • Power consumption: typically < 3.5 W, see Chapter Guppy PRO F-095C on page 46

Table 1: Document history

Manual overview

This **manual overview** describes each chapter of this manual shortly.

- Chapter [Contacting Allied Vision Technologies](#) on page 9 lists AVT contact data for both:
 - technical information / ordering
 - commercial information
- Chapter [Introduction](#) on page 10 (this chapter) gives you the document history, a manual overview and conventions used in this manual (styles and symbols). Furthermore you learn how to get more information on **how to install hardware (Hardware Installation Guide)**, available **AVT software** (incl. documentation) and where to get it.
- Chapter [Guppy PRO cameras](#) on page 21 gives you a short introduction to the Guppy PRO cameras with their FireWire technology. Links are provided to data sheets and brochures on AVT website.
- Chapter [Conformity](#) on page 22 gives you information about conformity of AVT cameras.
- Chapter [FireWire](#) on page 23 describes the FireWire standard in detail, explains the compatibility between 1394a and 1394b and explains bandwidth details (incl. Guppy PRO examples).

- Read and follow the **FireWire hot-plug and screw-lock precautions** in [Chapter FireWire hot-plug and screw-lock precautions on page 32](#).
- Read [Chapter Operating system support on page 33](#).
- Chapter [Filter and lenses](#) on page 34 describes the IR cut filter and suitable camera lenses.
- Chapter [Specifications](#) on page 38 lists camera details and spectral sensitivity diagrams for each camera type.
- Chapter [Camera dimensions](#) on page 66 provides CAD drawings of standard housing (copper and GOF) models, tripod adapter, available angled head models, cross sections of CS-Mount and C-Mount.
- Chapter [Camera interfaces](#) on page 70 describes in detail the inputs/outputs of the cameras (incl. Trigger features). For a general description of the interfaces (FireWire and I/O connector) see **Hardware Installation Guide**.
- Chapter [Description of the data path](#) on page 94 describes in detail IIDC conform as well as AVT-specific camera features.
- Chapter [Controlling image capture](#) on page 139 describes trigger modes, exposure time, one-shot/multi-shot/ISO_Enable features.
- Chapter [Video formats, modes and bandwidth](#) on page 162 lists all available fixed and Format_7 modes (incl. color modes, frame rates, binning/sub-sampling, AOI=area of interest).
- Chapter [How does bandwidth affect the frame rate?](#) on page 199 gives some considerations on bandwidth details.
- Chapter [Configuration of the camera](#) on page 203 lists standard and advanced register descriptions of all camera features.
- Chapter [Firmware update](#) on page 271 explains where to get information on firmware updates and explains the extended version number scheme of FPGA/ μ C.
- Chapter [Appendix](#) on page 272 lists the sensor position accuracy of AVT cameras.
- Chapter [Index](#) on page 273 gives you quick access to all relevant data in this manual.

Conventions used in this manual

To give this manual an easily understood layout and to emphasize important information, the following typographical styles and symbols are used:

Styles

Style	Function	Example
Bold	Programs, inputs or highlighting important things	bold
Courier	Code listings etc.	Input
Upper case	Register	REGISTER
Italics	Modes, fields	<i>Mode</i>
Parentheses and/or blue	Links	(Link)

Table 2: Styles

Symbols

Note This symbol highlights important information.



Caution This symbol highlights important instructions. You have to follow these instructions to avoid malfunctions.



www This symbol highlights URLs for further information. The URL itself is shown in blue.



Example:

<http://www.alliedvisiontec.com>

More information

For more information on hardware and software read the following:

- **Hardware Installation Guide** describes the hardware installation procedures for all 1394 AVT cameras (Oscar, Marlin, Guppy, Pike, Stingray, Guppy PRO). Additionally you get safety instructions and information about camera interfaces (IEEE 1394a/b copper and GOF, I/O connectors, input and output).

www



For downloading the Hardware Installation Guide go to:

<http://www.alliedvisiontec.com/emea/support/downloads/product-literature.html>

There is no product CD.

www



All **software packages** (including **documentation** and **release notes**) provided by AVT can be downloaded at:

<http://www.alliedvisiontec.com/emea/products/software.html>

All software packages are also on AVT's product CD.

Before operation

We place the highest demands for quality on our cameras.

Target group

This **Technical Manual** is the guide to detailed technical information of the camera and **is written for experts**.

Getting started

For a quick guide how to get started read **Hardware Installation Guide** first.

Note



Please read through this manual carefully before operating the camera.

For information on **AVT accessories** and **AVT software** read **Hardware Installation Guide**.

Caution



Before operating any AVT camera read **safety instructions** and **ESD warnings** in **Hardware Installation Guide**.

www



To demonstrate the properties of the camera, you find some samples on **SmartView** which is part of **AVT FirePackage**. A free version is available for download at:

<http://www.alliedvisiontec.com/emea/products/software.html>

Note



The camera also works with all IIDC (formerly DCAM) compatible IEEE 1394 programs and image processing libraries.

Guppy PRO cameras

Guppy PRO With Guppy PRO cameras, entry into the world of digital image processing is simpler and more **cost-effective** than ever before. Guppy PRO cameras are the smallest 1394b cameras worldwide.

IEEE 1394b With the new Guppy PRO, Allied Vision Technologies presents a wide range of cameras with **IEEE 1394b interfaces**.

Image applications Allied Vision Technologies can provide users with a range of products that meet almost all the requirements of a very wide range of image applications.

FireWire The industry standard IEEE 1394 (FireWire or i.Link) facilitates the simplest computer compatibility and bidirectional data transfer. Further development of the IEEE 1394 standard has already made 800 Mbit/second possible. Investment in this standard is therefore secure for the future; each further development takes into account compatibility with the preceding standard, and vice versa, meaning that IEEE 1394b is backward-compatible with IEEE 1394a. Your applications will grow as technical progress advances.

Note For further information on **FireWire** read Chapter [FireWire](#) on page 23.



www For further information on the highlights of Guppy PRO **types**, the Guppy PRO **family** and the whole range of **AVT FireWire cameras** read the data sheets and brochures on the website of Allied Vision Technologies:



www.alliedvisiontec.com

Conformity

Allied Vision Technologies declares under its sole responsibility that all standard cameras of the **AVT Guppy PRO** family to which this declaration relates are in conformity with the following standard(s) or other normative document(s):

- CE, following the provisions of 2004/108/EG directive
- FCC Part 15 Class B
- RoHS (2002/95/EC)

CE

We declare, under our sole responsibility, that the previously described **AVT Guppy PRO** cameras conform to the directives of the CE.

FCC – Class B Device

Note: This equipment has been tested and found to comply with the limits for a Class B digital device, pursuant to part 15 of the FCC Rules. These limits are designed to provide reasonable protection against harmful interference in a residential environment. This equipment generates, uses, and can radiate radio frequency energy and, if not installed and used in accordance with the instructions, may cause harmful interference to radio communications. Operation of this equipment in a residential area is likely to cause harmful interference in which case the user will be required to correct the interference at his own expense. You are cautioned that any changes or modifications not expressly approved in this manual could void your authority to operate this equipment.

FireWire

Overview

FireWire provides one of the most comprehensive, high-performance, cost-effective solutions platforms. **FireWire** offers very impressive throughput at very affordable prices.

Definition

FireWire (also known as **i.Link** or **IEEE 1394**) is a personal computer and digital video serial bus interface standard, offering high-speed communications and isochronous real-time data services. **FireWire** has low implementation costs and a simplified and adaptable cabling system.



Figure 1: FireWire Logo

IEEE 1394 standards

FireWire was developed by Apple Computer in the late 1990s, after work defining a slower version of the interface by the IEEE 1394 working committee in the 1980s. Apple's development was completed in 1995. It is defined in IEEE standard 1394 which is currently a composite of three documents:

- the original IEEE Std. 1394-1995
- the IEEE Std. 1394a-2000 amendment
- the IEEE Std. 1394b-2002 amendment

FireWire is used to connect digital cameras, especially in industrial systems for machine vision.

Why use FireWire?

Digital cameras with on-board **FireWire** (IEEE 1394a or 1394b) communications conforming to the IIDC standard (V1.3 or V1.31) have created cost-effective and powerful solutions options being used for thousands of different applications around the world. **FireWire** is currently the premier robust digital interface for industrial applications for many reasons, including:

- Guaranteed bandwidth features to ensure fail-safe communications
- Interoperability with multiple different camera types and vendors

- Diverse camera powering options, including single-cable solutions up to 45 W
- Effective multiple-camera solutions
- Large variety of **FireWire** accessories for industrial applications
- Availability of repeaters and optical fibre cabling
- Forwards and backward compatibility blending 1394a and 1394b
- Both real-time (isochronous) and demand-driven asynchronous data transmission capabilities

FireWire in detail

Serial bus

Briefly summarized, **FireWire** is a very effective way to utilize a low-cost serial bus, through a standardized communications protocol, that establishes packetized data transfer between two or more devices. FireWire offers real time isochronous bandwidth for image transfer with guaranteed low latency. It also offers asynchronous data transfer for controlling camera parameters, such as gain and shutter, on the fly. As illustrated in the diagram below, these two modes can co-exist by using priority time slots for video data transfer and the remaining time slots for control data transfer.

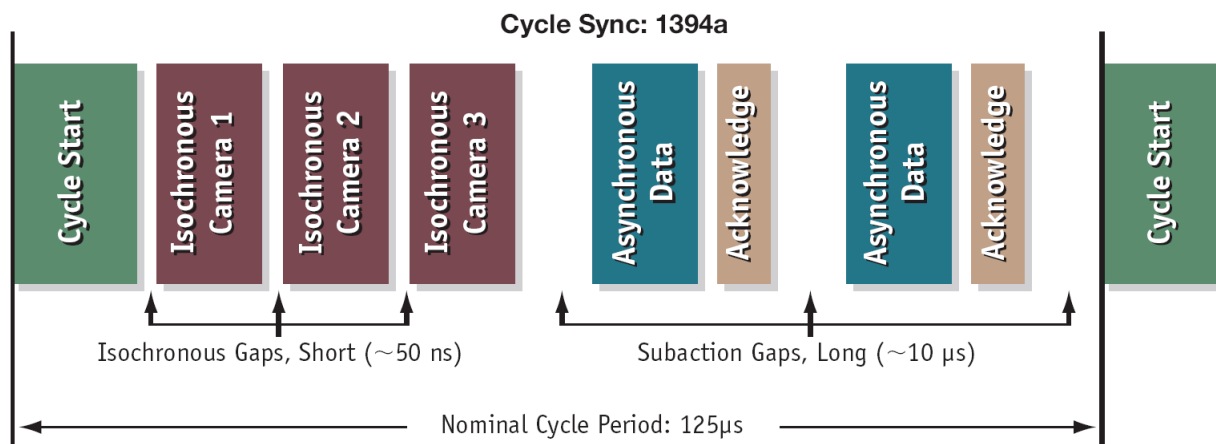

Figure 2: 1394a data transmission

In case of 1394b no gaps are needed due to parallel arbitration, handled by bus owner supervisor selector (BOSS) (see the following diagram). Whereas 1394a works in half duplex transmission, 1394 does full duplex transmission.

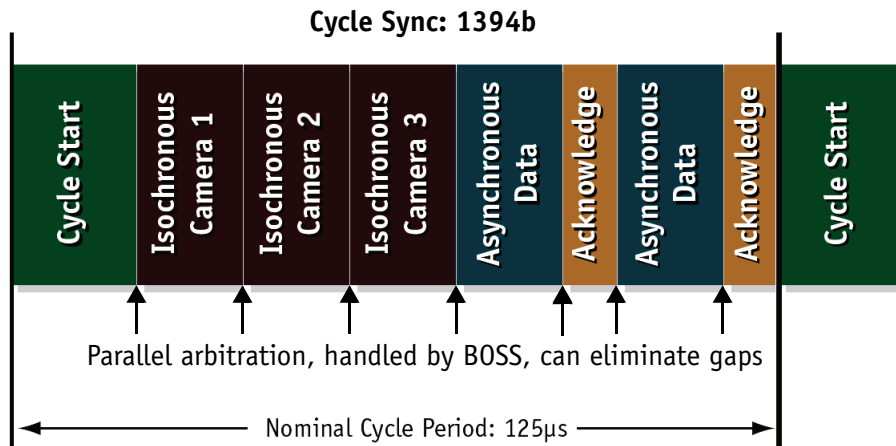

Figure 3: 1394b data transmission

Additional devices may be added up to the overall capacity of the bus, but throughput at guaranteed minimum service levels is maintained for all devices with an acknowledged claim on the bus. This deterministic feature is a huge advantage for many industrial applications where robust performance is required. Such is the case when it is not acceptable to drop images within a specific time interval.

Note

How to extend the size of an isochronous packet up to 11.000 byte at S800:



- see register 0xF1000048, ADV_INQ_3, Max IsoSize [1] in [Table 124: Advanced register: Advanced feature inquiry](#) on page 241
- see Chapter [Maximum ISO packet size](#) on page 260

FireWire connection capabilities

FireWire can connect together up to 63 peripherals in an acyclic network structure (hubs). It allows peer-to-peer device communication (between digital cameras), to take place without using system memory or the CPU.

But even more importantly, a **FireWire camera** can directly, via direct memory access (DMA), write into or read from the memory of the computer with almost no CPU load.

FireWire also supports multiple hosts per bus. **FireWire** requires only a cable with the correct number of pins on either end (normally 6 or 9). It is designed to support plug-and-play and hot swapping. It can supply up to 45 W of power per port at 30 V, allowing high consumption devices to operate without a separate power cord.

Caution



While supplying such an amount of bus power is clearly a beneficial feature, it is **very** important **not** to exceed the inrush current of 18 mJoule in 3 ms.

Higher inrush current may damage the Phy chip of the camera and/or the Phy chip in your PC.

Capabilities of 1394a (FireWire 400)

FireWire 400 (S400) is able to transfer data between devices at 100, 200 or 400 MBit/s data rates. Although USB 2.0 claims to be capable of higher speeds (480 Mbit/s), FireWire is, in practice, not slower than USB 2.0.

The 1394a capabilities in detail:

- 400 Mbit/s
- Hot-pluggable devices
- Peer-to-peer communications
- Direct Memory Access (DMA) to host memory
- Guaranteed bandwidth
- Multiple devices (up to 45 W) powered via FireWire bus

IIDC V1.3 camera control standards

IIDC V1.3 released a set of camera control standards via 1394a which established a common communications protocol on which most current FireWire cameras are based.

In addition to common standards shared across manufacturers, a special Format_7 mode also provided a means by which a manufacturer could offer special features (smart features), such as:

- higher resolutions
- higher frame rates
- diverse color modes

as extensions (advanced registers) to the prescribed common set.

Capabilities of 1394b (FireWire 800)

FireWire 800 (S800) was introduced commercially by Apple in 2003 and has a 9-pin FireWire 800 connector (see details in **Hardware Installation Guide** and in Chapter [IEEE 1394b port pin assignment](#) on page 70). This newer 1394b specification allows a transfer rate of 800 MBit/s with backward compatibilities to the slower rates and 6-pin connectors of FireWire 400.

The 1394b capabilities in detail:

- 800 Mbit/s
- All previous benefits of 1394a (see above)
- Interoperability with 1394a devices
- Longer communications distances (up to 500 m using GOF cables)

IIDC V1.31 camera control standards

Twinned with 1394b, the IIDC V1.31 standard arrived in January 2004, evolving the industry standards for digital imaging communications to include I/O and RS232 handling, and adding further formats. At such high bandwidths it has become possible to transmit high-resolution images to the PC's memory at very high frame rates.

Compatibility between 1394a and 1394b

 <p>1394a camera connected to 1394b bus</p> <p>The cable explains dual compatibility: This cable serves to connect an IEEE 1394a camera with its six-pin connector to a bilingual port (a port which can talk in a- or b-language) of a 1394b bus.</p> <p>In this case the b-bus communicates in a-language and a-speed with the camera achieving a-performance</p>	 <p>1394b camera connected to 1394a bus</p> <p>The cable explains dual compatibility: In this case, the cable connects an IEEE 1394b camera with its nine-pin connector to a 1394a port.</p> <p>In this case the b-camera communicates in a-language with the camera achieving a-performance</p>
---	---

Figure 4: 1394a and 1394b cameras and compatibility

Compatibility example

It's possible to run a 1394a and a 1394b camera on the 1394b bus.

You can e.g. run a Guppy PRO F-032B and a Marlin F-033B on the same bus:

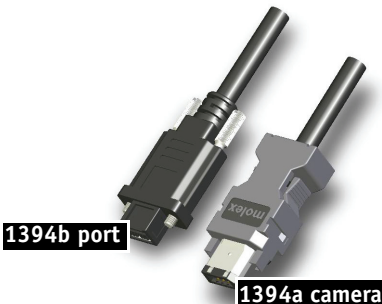
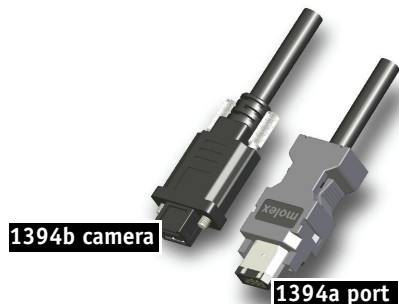
- Guppy PRO F-032B @ S800 and 60 fps (2560 bytes per cycle, 32% of the cycle slot)
- Marlin F-033B @ S400 and 30 fps (1280 bytes, 32% of the cycle slot)

Bus runs at 800 Mbit/s for all devices. Data from Marlin's port is up-converted from 400 Mbit/s to 800 Mbit/s by data doubling (padding), still needing 32% of the cycle slot time. This doubles the bandwidth requirement for this port, as if the camera were running at 60 fps. Total consumption is thus $2560 + 2560 = 5120$ bytes per cycle.

Image transfer via 1394a and 1394b

Technical detail	1394a	1394b
Transmission mode	Half duplex (both pairs needed) 400 Mbit/s data rate aka: a-mode, data/strobe (D/S) mode, legacy mode	Full duplex (one pair needed) 1 Gbit/s signaling rate, 800 Mbit/s data rate 10b/8b coding (Ethernet), aka: b-mode (beta mode)
Devices	Up to 63 devices per network	
Number of cameras	Up to 16 cameras per network	
Number of DMAs	4 to 8 DMAs (parallel) cameras / bus	
Real time capability	Image has real time priority	
Available bandwidth acc. IIDC (per cycle 125 μ s)	4096 bytes per cycle ~ 1000q @ 400 Mbit/s	8192 bytes per cycle ~ 2000q @ 800 Mbit/s (@1 GHz clock rate)
	For further detail read Chapter Frame rates on page 184.	
Max. image bandwidth	31.25 MByte/s	62.5 MByte/s
Max. total bandwidth	~45 MByte/s	~85 MByte/s
Number of busses	Multiple busses per PC limit: PCI bus	Multiple busses per PC limit: PCI (Express) bus
CPU load	Almost none for DMA image transfer	
Gaps	Gaps negatively affect asynchronous performance of widespread network (round trip delay), reducing efficiency	No gaps needed, BOSS mode for parallel arbitration

Table 3: Technical detail comparison: 1394a and 1394b

Note

The bandwidth values refer to the fact:

1 MByte = 1024 kByte



1394b bandwidths

According to the 1394b specification on isochronous transfer, the largest recommended data payload size is 8192 bytes per 125 μ s cycle at a bandwidth of 800 Mbit/s.

Note



Certain cameras may offer, depending on their settings in combination with the use of AVT FirePackage higher packet sizes.

Consult your local dealer's support team, if you require additional information on this feature.

For further details read Chapter [How does bandwidth affect the frame rate?](#) on page 199.

Requirements for PC and 1394b

One Guppy PRO camera connected to a PC's 1394b bus can saturate the standard PCI bus.

1394b also requires low latency for data transmission (due to small receive-FIFO). In order to get the most out of your camera-to-PC configuration, we recommend the following chipsets for your PC:

- For Intel-based desktops, chipset 945 (or higher)
- For non-Intel based desktops (e.g. AMD), PCI Express compatible chipset

www



For more information:

<http://support.intel.com/support/chipsets/#desktop>

For multi-camera applications one of the following bus cards is needed:

- PCI ExpressCard with potential 250 MByte/s per lane (up to 6 supported by chipset) or
- 64-bit PCI-X card (160 MByte/s)

Caution



As mentioned earlier, it is **very** important **not** to exceed an inrush current of 18 mJoule in 3 ms. (This means that a device, when powered via 12 V bus power must **never** draw more than 1.5 A, even not in the first 3 ms.)

Higher inrush current may damage the physical interface chip of the camera and/or the phy chip in your PC.

Whereas inrush current is not a problem for one 1394b camera, supplying bus power via (optional) HIROSE power out to circuitry with unknown inrush currents needs careful design considerations to be on the safe side.

Requirements for laptop and 1394b

As mentioned above, 1394b requires low latency for data transmission (small receive-FIFO). In order to get the most out of your camera-to-laptop configuration, we recommend the following chipset for your laptop:

- For Intel-based laptops, chipset 915 (or higher)
- For non-Intel based laptops (e.g. AMD), PCI Express compatible chipset

Because most laptops have (only) one PC-card interface, it is possible to connect one Guppy PRO camera to your laptop at full speed. Alternatively laptops with an additional 1394 ExpressCard interface can be used.

Note



Recent developments at Apple allow the INTEL based Apple computers (both laptops as well as desktops) to run a Windows operating system. This makes it possible to use AVT 1394 camera technology with the same AVT-SDKs.

ExpressCard Technology vs. CardBus

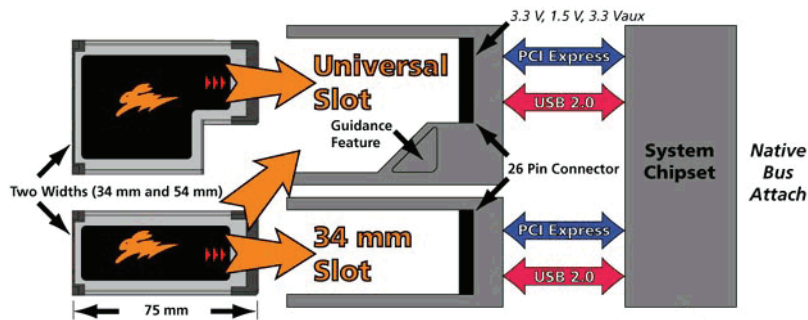

Figure 5: ExpressCard technology

www



ExpressCard is a new standard set by PCMCIA.

For more information visit:

<http://www.expresscard.org/web/site/>

Example 1: 1394b bandwidth of Guppy PRO cameras

Guppy PRO model	Resolution	Frame rate	Bandwidth
Guppy PRO F-031B/C	0.3 megapixels	123fps	39 MByte/s
Guppy PRO F-032B/C	0.3 megapixels	82 fps	26 MByte/s
Guppy PRO F-033B/C	0.3 megapixels	84 fps	27 MByte/s
Guppy PRO F-046B/C	0.45 megapixels	61 fps	28 MByte/s
Guppy PRO F-095C	0.9 megapixels	38 fps	36 MByte/s
Guppy PRO F-125B/C	1.2 megapixels	31 fps	38 MByte/s
Guppy PRO F-146B/C	1.4 megapixels	17 fps	20 MByte/s
Guppy PRO F-201B/C	2.0 megapixels	14 fps	28 MByte/s
Guppy PRO F-503B/C	5.0 megapixels	13 fps	65 MByte/s

Table 4: Bandwidth of Guppy PRO cameras

Note



All data are calculated using Raw8 / Mono8 color mode. Higher bit depths or color modes will double or triple bandwidth requirements.

Example 2: More than one Guppy PRO camera at full speed

Due to the fact that one Guppy PRO camera can, depending on its settings, saturate a 32-bit PCI bus, you are advised to use either a PCI Express card and/or multiple 64-bit PCI bus cards, if you want to use 2 or more Guppy PRO cameras simultaneously (see the following table).

# cameras	PC hardware required
1 Guppy PRO camera at full speed	1 x 32-bit PCI bus card (85 MByte/s)
2 or more Guppy PRO cameras at full speed	PCI Express card and/or Multiple 64-bit PCI bus cards

Table 5: Required hardware for multiple camera applications

FireWire Plug & play capabilities

FireWire devices implement the ISO/IEC 13213 **configuration ROM** model for device configuration and identification, to provide plug & play capability. All FireWire devices are identified by an IEEE EUI-64 unique identifier (an extension of the 48-bit Ethernet MAC address format) in addition to well-known codes indicating the type of device and protocols it supports. For further details read Chapter [Configuration of the camera](#) on page 203.

FireWire hot-plug and screw-lock precautions

Caution



Hot-plug precautions

- Although FireWire devices can **theoretically** be hot-plugged without powering down equipment, **we strongly recommend turning the computer power off, before connecting a digital camera** to it via a FireWire cable.
- **Static electricity or slight plug misalignment during insertion may short-circuit and damage components.**
- The physical ports **may be damaged** by **excessive ESD** (electrostatic discharge), when connected under powered conditions. It is good practice to ensure proper grounding of computer case and camera case to the same ground potential, before plugging the camera cable into the port of the computer. This ensures that no excessive difference of electrical potential exists between computer and camera.
- As mentioned earlier, it is **very important not** to exceed the **inrush energy of 18 mJoule in 3 ms**. (This means that a device, when powered via 12 V bus power must NEVER draw more than 1.5 A, but only 0.5 A in the first 3 ms, assuming constant flow of current.)
- Higher inrush current over longer periods **may damage the physical interface chip of the camera and/or the phy chip in your PC**. Whereas inrush current is not a problem for one Guppy PRO camera, daisy chaining multiple cameras or supplying bus power via (optional) HIROSE power out to circuitry with unknown inrush currents needs careful design considerations to be on the safe side.

Screw-lock precautions

- Also, all AVT 1394b camera and cables have **industrial screw-lock fasteners**, to insure a tight electrical connection that is resistant to vibration and gravity.
- **We strongly recommend using only 1394b adapter cards with screw-locks.**

Operating system support

Operating system	1394a	1394b
Linux	Full support	Full support
Apple Mac OS X	Full support	Full support
Windows XP	<p>With SP2 / SP3 the default speed for 1394b is S100 (100 Mbit/s). A download and registry modification is available from Microsoft to restore performance to either S400 or S800.</p> <p>http://support.microsoft.com/kb/885222</p> <p>Alternatively use the drivers of SP1 instead: Microsoft Windows XP SP2 and XP SP3 do not correctly support IEEE 1394b FireWire adapters. Downgrading the Windows XP FireWire bus driver to the SP1 version is required for IEEE 1394a or 1394b FireWire cameras to work correctly on an IEEE 1394b adapter, or if you want to use a 1394b FireWire camera with an IEEE 1394a adapter.</p> <p>Or: use either the driver of the AVT Universal Package/ AVT FirePackage or install the driver provided with the AVT 1394 Bus Driver Package. Both drivers replace the Microsoft OHCI IEEE 1394 driver, but the second is 100% compliant to the driver of Microsoft. This means, applications using the MS1394 driver will continue to work.</p>	
Windows Vista	Full support	<p>Windows Vista incl. SP1/SP2 supports 1394b only with S400.</p> <p>Use either the driver of the AVT Universal Package/ AVT FirePackage or install the driver provided with the AVT 1394 Bus Driver Package. Both drivers replace the Microsoft OHCI IEEE 1394 driver, but the second is 100% compliant to the driver of Microsoft. This means, applications using the MS1394 driver will continue to work.</p>
Windows 7	Full support	Full support

Table 6: FireWire and operating systems

www



For more information see **AVT Software Selector Guide:**

<http://www.alliedvisiontec.com/emea/support/downloads/software.html>

Filter and lenses

IR cut filter: spectral transmission

The following illustration shows the spectral transmission of the IR cut filter:

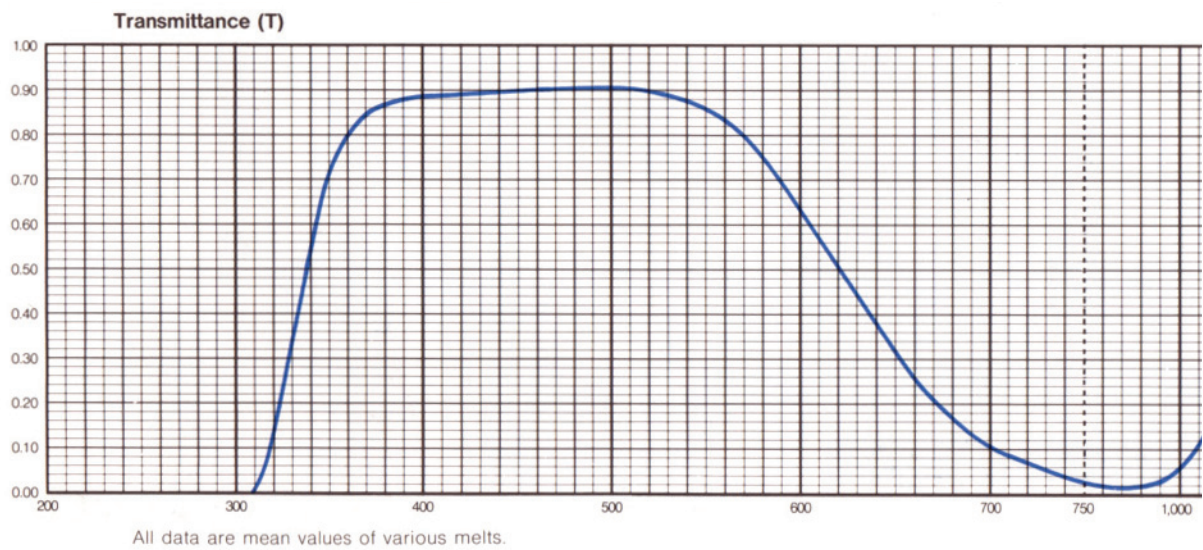

Figure 6: Approximate spectral transmission of IR cut filter (may vary slightly by filter lot)
(type Hoya C5000)

Camera lenses

AVT offers different lenses from a variety of manufacturers. The following table lists selected image formats in **width x height** depending on camera type, distance and the focal length of the lens.

Note All calculations apply to the principle planes of the lenses: these are unknown (real lenses are not infinite thin).



All calculations are valid only for a distortion free optical image (among other things: not valid for fisheye lenses).

Focal length for type 1/4 sensors Guppy PRO F-031	Distance = 500 mm	Distance = 1000 mm
2.8 mm	652 mm x 492 mm	1307 mm x 987 mm
4 mm	455 mm x 343 mm	914 mm x 690 mm
4.2 mm	433 mm x 327 mm	870 mm x 657 mm
4.8 mm	379 mm x 286 mm	761 mm x 574 mm
6 mm	302 mm x 228 mm	608 mm x 459 mm
6.5 mm	279 mm x 210 mm	561 mm x 423 mm
8 mm	226 mm x 170 mm	455 mm x 343 mm
12 mm	149 mm x 113 mm	302 mm x 228 mm
16 mm	111 mm x 84 mm	226 mm x 170 mm
25 mm	70 mm x 53 mm	143 mm x 108 mm

Table 7: Focal length vs. field of view (Guppy PRO F-031)

Focal length for type 1/3 sensor Guppy PRO F-032	Distance = 500 mm	Distance = 1000 mm
2.8 mm	867 mm x 648 mm	1738 mm x 1300 mm
4 mm	605 mm x 453 mm	1215 mm x 909 mm
4.2 mm	576 mm x 431 mm	1157 mm x 865 mm
4.8 mm	503 mm x 377 mm	1012 mm x 757 mm
6 mm	402 mm x 301 mm	808 mm x 605 mm
6.5 mm	371 mm x 277 mm	746 mm x 558 mm
8 mm	300 mm x 224 mm	605 mm x 453 mm
12 mm	198 mm x 148 mm	402 mm x 301 mm
16 mm	148 mm x 110 mm	300 mm x 224 mm
25 mm	93 mm x 69 mm	190 mm x 142 mm

Table 8: Focal length vs. field of view (Guppy PRO F-032)

Focal length for type 1/3 sensor Guppy PRO F-095	Distance = 500 mm	Distance = 1000 mm
4.8 mm	539 mm x 303 mm	1082 mm x 610 mm
6 mm	430 mm x 242 mm	865 mm x 487 mm
6.5 mm	396 mm x 223 mm	798 mm x 449 mm
8 mm	321 mm x 181 mm	647 mm x 365 mm
12 mm	212 mm x 120 mm	430 mm x 242 mm
16 mm	158 mm x 89 mm	321 mm x 181 mm
25 mm	99 mm x 56 mm	204 mm x 115 mm
35 mm	69 mm x 39 mm	144 mm x 81 mm
50 mm	47 mm x 26 mm	99 mm x 56 mm
75 mm	30 mm x 17 mm	64 mm x 36 mm

Table 9: Focal length vs. field of view (Guppy PRO F-095)

Focal length for type 1/2.5 sensors Guppy PRO F-503	Distance = 0.5 m	Distance = 1 m
4.8 mm	0.44 m x 0.59 m	0.89 m x 1.18 m
8 mm	0.26 m x 0.35 m	0.53 m x 0.70 m
12 mm	0.17 m x 0.23 m	0.35 m x 0.47 m
16 mm	0.13 m x 0.17 m	0.26 m x 0.35 m
25 mm	0.08 m x 0.11 m	0.17 m x 0.22 m
35 mm	0.06 m x 0.08 m	0.12 m x 0.16 m
50 mm	0.04 m x 0.05 m	0.08 m x 0.11 m

Table 10: Focal length vs. field of view (Guppy PRO F-503)

Focal length for type 1/2 sensors Guppy PRO F-033/046/146	Distance = 500 mm	Distance = 1000 mm
4.8 mm	660 mm x 495 mm	1327 mm x 995 mm
8 mm	394 mm x 295 mm	794 mm x 595 mm
12 mm	260 mm x 195 mm	527 mm x 395 mm
16 mm	194 mm x 145 mm	394 mm x 295 mm
25 mm	122 mm x 91 mm	250 mm x 187 mm
35 mm	85 mm x 64 mm	176 mm x 132 mm
50 mm	58 mm x 43 mm	122 mm x 91 mm

Table 11: Focal length vs. field of view (Guppy PRO F-033/046/146)

Focal length for type 1/1.8 sensors Guppy PRO F-201	Distance = 500 mm	Distance = 1000 mm
4.8 mm	740 mm x 549 mm	1488 mm x 1103 mm
8 mm	441 mm x 327 mm	890 mm x 660 mm
12 mm	292 mm x 216 mm	591 mm x 438 mm
16 mm	217 mm x 161 mm	441 mm x 327 mm
25 mm	136 mm x 101 mm	280 mm x 207 mm
35 mm	95 mm x 71 mm	198 mm x 147 mm
50 mm	65 mm x 48 mm	136 mm x 101 mm

Table 12: Focal length vs. field of view (Guppy PRO F-201)

Note



Lenses with focal lengths < 8 mm may show shading in the edges of the image and due to micro lenses on the sensor's pixel.

Ask your dealer if you require non C-Mount lenses.

Specifications

Note



- For information on bit/pixel and byte/pixel for each color mode see [Table 99: ByteDepth](#) on page 200.
- **Maximum protrusion** means the **distance from lens flange to the glass filter in the camera.**

Guppy PRO F-031B/C

Feature	Specification
Image device	Type 1/4 (diag. 4.5 mm) progressive scan SONY IT CCD ICX618AL/AQA with EXview HAD microlens
Effective chip size	3.6 mm x 2.7 mm
Cell size	5.6 μm x 5.6 μm
Picture size (max.)	656 x 492 pixels (Format_7 Mode_0)
Lens mount	Adjustable C-Mount: 17.526 mm (in air); \emptyset 25.4 mm (32 tpi) maximum protrusion: 10.1 mm (see Figure 26: Guppy PRO C-Mount dimensions on page 68)
	<p>Note Maximum protrusion means the distance from lens flange to the glass filter in the camera.</p> 
ADC	14 bit
Color modes	Only color: Raw8, Raw12, Raw16, Mono8, YUV411, YUV422, RGB8
Frame rates	1.875 fps; 3.75 fps; 7.5 fps; 15 fps; 30 fps; 60 fps; 120 fps Up to 123 fps in Format_7
Gain control	Manual: 0-24.4 dB (0.0359 dB/step); auto gain (select. AOI)
Shutter speed	75 μs ... 67,108,864 μs (~ 67 s); auto shutter (select. AOI)
External trigger shutter	Programmable, trigger level control, single trigger, bulk trigger, programmable trigger delay
Look-up tables	User programmable (12 bit \rightarrow 10 bit); default gamma (0.45)

Table 12: Specification Guppy PRO F-031B/C

Feature	Specification
Smart functions	AGC (auto gain control), AEC (auto exposure control), autofunction AOI, LUT, binning (only b/w), sub-sampling (only b/w), color correction, hue, saturation, 1 storable user set only color: AWB (auto white balance)
I/Os	One configurable input (optocoupled), three configurable outputs (optocoupled)
Transfer rate	100 Mbit/s, 200 Mbit/s, 400 Mbit/s, 800 Mbit/s
Digital interface	IEEE 1394b (IIDC V1.31), 1 x copper connector
Power requirements	DC 8 V - 36 V via IEEE 1394 cable or 12-pin HIROSE
Power consumption	Typical <3.5 watt (@ 12 V DC) (full resolution and maximal frame rates)
Dimensions	44.8 mm x 29 mm x 29 mm (L x W x H); incl. connectors, without tripod and lens
Mass	75 g (without lens) + 5 g filter ring
Operating temperature	+ 5 °C ... + 45 °C ambient temperature (non-condensing)
Storage temperature	- 10 °C ... + 70 °C ambient temperature (non-condensing)
Regulations	CE, FCC Class B, RoHS (2002/95/EC)
Standard accessories	b/w: protection glass color: IR cut filter
Optional accessories	b/w: IR cut filter, IR pass filter color: protection glass
On request	Host adapter card, power out 6 W (HIROSE)
Software packages	API (FirePackage, Fire4Linux)

Table 12: Specification Guppy PRO F-031B/C

Note

The design and specifications for the products described above may change without notice.



Guppy PRO F-032B/C

Feature	Specification
Image device	Type 1/3 (diag. 6 mm) progressive scan SONY IT CCD ICX424AL/AQ with HAD microlens
Effective chip size	4.9 mm x 3.7 mm
Cell size	7.4 μm x 7.4 μm
Picture size (max.)	656 x 492 pixels (Format_7 Mode_0)
Lens mount	Adjustable C-Mount: 17.526 mm (in air); \varnothing 25.4 mm (32 tpi) maximum protrusion: 10.1 mm (see Figure 26: Guppy PRO C-Mount dimensions on page 68) Note  Maximum protrusion means the distance from lens flange to the glass filter in the camera.
ADC	12 bit
Color modes	Only color: Raw8, Raw12, Raw16, Mono8, YUV411, YUV422, RGB8
Frame rates	1.875 fps; 3.75 fps; 7.5 fps; 15 fps; 30 fps; 60 fps Up to 82 fps in Format_7
Gain control	Manual: 0-24.4 dB (0.0359 dB/step); auto gain (select. AOI)
Shutter speed	37 μs ... 67,108,864 μs (~ 67 s); auto shutter (select. AOI)
External trigger shutter	Programmable, trigger level control, single trigger, bulk trigger, programmable trigger delay
Look-up tables	User programmable (12 bit \rightarrow 10 bit); default gamma (0.45)
Smart functions	AGC (auto gain control), AEC (auto exposure control), autofunction AOI, LUT, binning (only b/w), sub-sampling (only b/w), color correction, hue, saturation, 1 storable user set only color: AWB (auto white balance)
I/Os	One configurable input (optocoupled), three configurable outputs (optocoupled)
Transfer rate	100 Mbit/s, 200 Mbit/s, 400 Mbit/s, 800 Mbit/s
Digital interface	IEEE 1394b (IIDC V1.31), 1 x copper connector
Power requirements	DC 8 V - 36 V via IEEE 1394 cable or 12-pin HIROSE
Power consumption	Typical <3.5 watt (@ 12 V DC) (full resolution and maximal frame rates)
Dimensions	44.8 mm x 29 mm x 29 mm (L x W x H); incl. connectors, without tripod and lens

Table 13: Specification Guppy PRO F-032B/C

Feature	Specification
Mass	75 g (without lens) + 5 g filter ring
Operating temperature	+ 5 °C ... + 45 °C ambient temperature (non-condensing)
Storage temperature	- 10 °C ... + 70 °C ambient temperature (non-condensing)
Regulations	CE, FCC Class B, RoHS (2002/95/EC)
Standard accessories	b/w: protection glass color: IR cut filter
Optional accessories	b/w: IR cut filter, IR pass filter color: protection glass
On request	Host adapter card, power out 6 W (HIROSE)
Software packages	API (FirePackage, Fire4Linux)

Table 13: Specification Guppy PRO F-032B/C

Note

The design and specifications for the products described above may change without notice.



Guppy PRO F-033B/C

Feature	Specification
Image device	Type 1/2 (diag. 8 mm) progressive scan SONY IT CCD ICX414AL/AQ with HAD microlens
Effective chip size	7.48 mm x 6.15 mm
Cell size	9.9 μm x 9.9 μm
Picture size (max.)	656 x 492 pixels (Format_7 Mode_0)
Lens mount	Adjustable C-Mount: 17.526 mm (in air); \varnothing 25.4 mm (32 tpi) maximum protrusion: 10.1 mm (see Figure 26: Guppy PRO C-Mount dimensions on page 68) Note  Maximum protrusion means the distance from lens flange to the glass filter in the camera.
ADC	14 bit
Color modes	Only color: Raw8, Raw12, Raw16, Mono8, YUV411, YUV422, RGB8
Frame rates	1.875 fps; 3.75 fps; 7.5 fps; 15 fps; 30 fps; 60 fps Up to 85 fps in Format_7
Gain control	Manual: 0-24.4 dB (0.0359 dB/step); auto gain (select. AOI)
Shutter speed	31 μs ... 67,108,864 μs (~ 67 s); auto shutter (select. AOI)
External trigger shutter	Programmable, trigger level control, single trigger, bulk trigger, programmable trigger delay
Look-up tables	User programmable (12 bit \rightarrow 10 bit); default gamma (0.45)
Smart functions	AGC (auto gain control), AEC (auto exposure control), autofunction AOI, LUT, binning (only b/w), sub-sampling (only b/w), color correction, hue, saturation, 1 storable user set only color: AWB (auto white balance)
I/Os	One configurable input (optocoupled), three configurable outputs (optocoupled)
Transfer rate	100 Mbit/s, 200 Mbit/s, 400 Mbit/s, 800 Mbit/s
Digital interface	IEEE 1394b (IIDC V1.31), 1 x copper connector
Power requirements	DC 8 V - 36 V via IEEE 1394 cable or 12-pin HIROSE
Power consumption	Typical < 3.5 watt (@ 12 V DC) (full resolution and maximal frame rates)
Dimensions	44.8 mm x 29 mm x 29 mm (L x W x H); incl. connectors, without tripod and lens

Table 14: Specification Guppy PRO F-033B/C

Feature	Specification
Mass	75 g (without lens) + 5 g filter ring
Operating temperature	+ 5 °C ... + 45 °C ambient temperature (non-condensing)
Storage temperature	- 10 °C ... + 70 °C ambient temperature (non-condensing)
Regulations	CE, FCC Class B, RoHS (2002/95/EC)
Standard accessories	b/w: protection glass color: IR cut filter
Optional accessories	b/w: IR cut filter, IR pass filter color: protection glass
On request	Host adapter card, power out 6 W (HIROSE)
Software packages	API (FirePackage, Fire4Linux)

Table 14: Specification Guppy PRO F-033B/C

Note

The design and specifications for the products described above may change without notice.



Guppy PRO F-046B/C

Feature	Specification
Image device	Type 1/2 (diag. 8 mm) progressive scan SONY IT CCD ICX415AL/AQ with HAD microlens
Effective chip size	7.48 mm x 6.15 mm
Cell size	8.3 μm x 8.3 μm
Picture size (max.)	780 x 580 pixels (Format_7 Mode_0)
Lens mount	Adjustable C-Mount: 17.526 mm (in air); \varnothing 25.4 mm (32 tpi) maximum protrusion: 10.1 mm (see Figure 26: Guppy PRO C-Mount dimensions on page 68) Note Maximum protrusion means the distance from lens flange to the glass filter in the camera. 
ADC	14 bit
Color modes	Only color: Raw8, Raw12, Raw16, Mono8, YUV411, YUV422, RGB8
Frame rates	1.875 fps; 3.75 fps; 7.5 fps; 15 fps; 30 fps; 60 fps Up to 62 fps in Format_7
Gain control	Manual: 0-24.4 dB (0.0359 dB/step); auto gain (select. AOI)
Shutter speed	31 μs ... 67,108,864 μs (~ 67 s); auto shutter (select. AOI)
External trigger shutter	Programmable, trigger level control, single trigger, bulk trigger, programmable trigger delay
Look-up tables	User programmable (12 bit \rightarrow 10 bit); default gamma (0.45)
Smart functions	AGC (auto gain control), AEC (auto exposure control), autofunction AOI, LUT, binning (only b/w), sub-sampling (only b/w), color correction, hue, saturation, 1 storable user set only color: AWB (auto white balance)
I/Os	One configurable input (optocoupled), three configurable outputs (optocoupled)
Transfer rate	100 Mbit/s, 200 Mbit/s, 400 Mbit/s, 800 Mbit/s
Digital interface	IEEE 1394b (IIDC V1.31), 1 x copper connector
Power requirements	DC 8 V - 36 V via IEEE 1394 cable or 12-pin HIROSE
Power consumption	Typical < 3.5 watt (@ 12 V DC) (full resolution and maximal frame rates)
Dimensions	44.8 mm x 29 mm x 29 mm (L x W x H); incl. connectors, without tripod and lens

Table 15: Specification Guppy PRO F-046B/C

Feature	Specification
Mass	75 g (without lens) + 5 g filter ring
Operating temperature	+ 5 °C ... + 45 °C ambient temperature (non-condensing)
Storage temperature	- 10 °C ... + 70 °C ambient temperature (non-condensing)
Regulations	CE, FCC Class B, RoHS (2002/95/EC)
Standard accessories	b/w: protection glass color: IR cut filter
Optional accessories	b/w: IR cut filter, IR pass filter color: protection glass
On request	Host adapter card, power out 6 W (HIROSE)
Software packages	API (FirePackage, Fire4Linux)

Table 15: Specification Guppy PRO F-046B/C

Note

The design and specifications for the products described above may change without notice.



Guppy PRO F-095C

Feature	Specification
Image device	Type 1/3 (diag. 6 mm) progressive scan SONY IT CCD ICX692AQ with EXview HAD CCD II microlens
Effective chip size	5.22 mm x 2.94 mm
Cell size	4.08 μm x 4.08 μm
Picture size (max.)	1280 x 720 pixels (Format_7 Mode_0)
Lens mount	Adjustable C-Mount: 17.526 mm (in air); \varnothing 25.4 mm (32 tpi) maximum protrusion: 10.1 mm (see Figure 25: Guppy PRO C-Mount dimensions on page 63) Note Maximum protrusion means the distance from lens flange to the glass filter in the camera. 
ADC	14 bit
Color modes	Raw8, Raw12, Raw16, Mono8, YUV411, YUV422, RGB8
Frame rates	1.875 fps; 3.75 fps; 7.5 fps; 15 fps; 30 fps Up to 38 fps in Format_7 Mode_0
Gain control	Manual: 0-24.4 dB (0.0359 dB/step); auto gain (select. AOI)
Shutter speed	39 μs ... 67,108,864 μs (~ 67 s); auto shutter (select. AOI)
External trigger shutter	Programmable, trigger level control, single trigger, bulk trigger, programmable trigger delay
Look-up tables	User programmable (12 bit \rightarrow 10 bit); default gamma (0.45)
Smart functions	AGC (auto gain control), AEC (auto exposure control), autofunction AOI, LUT, binning (only b/w), sub-sampling (only b/w), color correction, hue, saturation, 1 storable user set AWB (auto white balance)
I/Os	One configurable input (optocoupled), three configurable outputs (optocoupled)
Transfer rate	100 Mbit/s, 200 Mbit/s, 400 Mbit/s, 800 Mbit/s
Digital interface	IEEE 1394b (IIDC V1.31), 1 x copper connector
Power requirements	DC 8 V - 36 V via IEEE 1394 cable or 12-pin HIROSE
Power consumption	Typical < 3.5 watt (@ 12 V DC) (full resolution and maximal frame rates)
Dimensions	44.8 mm x 29 mm x 29 mm (L x W x H); incl. connectors, without tripod and lens
Mass	75 g (without lens) + 5 g filter ring

Table 16: Specification Guppy PRO F-095C

Feature	Specification
Operating temperature	+ 5 °C ... + 45 °C ambient temperature (non-condensing)
Storage temperature	- 10 °C ... + 70 °C ambient temperature (non-condensing)
Regulations	CE, FCC Class B, RoHS (2002/95/EC)
Standard accessories	IR cut filter
Optional accessories	protection glass
On request	Host adapter card, power out 6 W (HIROSE)
Software packages	API (FirePackage, Fire4Linux)

Table 16: Specification Guppy PRO F-095C

Note

The design and specifications for the products described above may change without notice.



Guppy PRO F-125B/C

Feature	Specification
Image device	Type 1/3 (diag. 6 mm) progressive scan SONY IT CCD ICX445ALA/AQA with EXview HAD microlens
Effective chip size	4.8 mm x 3.6 mm
Cell size	3.75 μm x 3.75 μm
Picture size (max.)	1292 x 964 pixels (Format_7 Mode_0)
Lens mount	Adjustable C-Mount: 17.526 mm (in air); \varnothing 25.4 mm (32 tpi) maximum protrusion: 10.1 mm (see Figure 26: Guppy PRO C-Mount dimensions on page 68) Note  Maximum protrusion means the distance from lens flange to the glass filter in the camera.
ADC	14 bit
Color modes	Only color: Raw8, Raw12, Raw16, Mono8, YUV411, YUV422, RGB8
Frame rates	1.875 fps; 3.75 fps; 7.5 fps; 15 fps; 30 fps; 60 fps Up to 31 fps in Format_7
Gain control	Manual: 0-24.4 dB (0.0359 dB/step); auto gain (select. AOI)
Shutter speed	39 μs ... 67,108,864 μs (~ 67 s); auto shutter (select. AOI)
External trigger shutter	Programmable, trigger level control, single trigger, bulk trigger, programmable trigger delay
Look-up tables	User programmable (12 bit \rightarrow 10 bit); default gamma (0.45)
Smart functions	AGC (auto gain control), AEC (auto exposure control), autofunction AOI, LUT, binning (only b/w), sub-sampling (only b/w), color correction, hue, saturation, 1 storable user set only color: AWB (auto white balance)
I/Os	One configurable input (optocoupled), three configurable outputs (optocoupled)
Transfer rate	100 Mbit/s, 200 Mbit/s, 400 Mbit/s, 800 Mbit/s
Digital interface	IEEE 1394b (IIDC V1.31), 1 x copper connector
Power requirements	DC 8 V - 36 V via IEEE 1394 cable or 12-pin HIROSE
Power consumption	Typical <3.5 watt (@ 12 V DC) (full resolution and maximal frame rates)
Dimensions	44.8 mm x 29 mm x 29 mm (L x W x H); incl. connectors, without tripod and lens

Table 17: Specification Guppy PRO F-125B/C

Feature	Specification
Mass	75 g (without lens) + 5 g filter ring
Operating temperature	+ 5 °C ... + 45 °C ambient temperature (non-condensing)
Storage temperature	- 10 °C ... + 70 °C ambient temperature (non-condensing)
Regulations	CE, FCC Class B, RoHS (2002/95/EC)
Standard accessories	b/w: protection glass color: IR cut filter
Optional accessories	b/w: IR cut filter, IR pass filter color: protection glass
On request	Host adapter card, power out 6 W (HIROSE)
Software packages	API (FirePackage, Fire4Linux)

Table 17: Specification Guppy PRO F-125B/C

Note — The design and specifications for the products described above may change without notice.



Guppy PRO F-146B/C

Feature	Specification
Image device	Type 1/2 (diag. 8 mm) progressive scan SONY IT CCD ICX267AL/AK with HAD microlens
Effective chip size	6.5 mm x 4.8 mm
Cell size	4.65 μm x 4.65 μm
Picture size (max.)	1388 x 1038 pixels (Format_7 Mode_0)
Lens mount	Adjustable C-Mount: 17.526 mm (in air); \varnothing 25.4 mm (32 tpi) maximum protrusion: 10.1 mm (see Figure 26: Guppy PRO C-Mount dimensions on page 68) Note  Maximum protrusion means the distance from lens flange to the glass filter in the camera.
ADC	12 bit
Color modes	Only color: Raw8, Raw12, Raw16, Mono8, YUV411, YUV422, RGB8
Frame rates	1.875 fps; 3.75 fps; 7.5 fps; 15 fps; 30 fps Up to 17 fps in Format_7
Gain control	Manual: 0-24.4 dB (0.0359 dB/step); auto gain (select. AOI)
Shutter speed	45 μs ... 67,108,864 μs (~ 67 s); auto shutter (select. AOI)
External trigger shutter	Programmable, trigger level control, single trigger, bulk trigger, programmable trigger delay
Look-up tables	User programmable (12 bit \rightarrow 10 bit); default gamma (0.45)
Smart functions	AGC (auto gain control), AEC (auto exposure control), autofunction AOI, LUT, binning (only b/w), sub-sampling (only b/w), color correction, hue, saturation, 1 storable user set only color: AWB (auto white balance)
I/Os	One configurable input (optocoupled), three configurable outputs (optocoupled)
Transfer rate	100 Mbit/s, 200 Mbit/s, 400 Mbit/s, 800 Mbit/s
Digital interface	IEEE 1394b (IIDC V1.31), 1 x copper connector
Power requirements	DC 8 V - 36 V via IEEE 1394 cable or 12-pin HIROSE
Power consumption	Typical <3.5 watt (@ 12 V DC) (full resolution and maximal frame rates)
Dimensions	44.8 mm x 29 mm x 29 mm (L x W x H); incl. connectors, without tripod and lens

Table 18: Specification Guppy PRO F-146B/C

Feature	Specification
Mass	75 g (without lens) + 5 g filter ring
Operating temperature	+ 5 °C ... + 45 °C ambient temperature (non-condensing)
Storage temperature	- 10 °C ... + 70 °C ambient temperature (non-condensing)
Regulations	CE, FCC Class B, RoHS (2002/95/EC)
Standard accessories	b/w: protection glass color: IR cut filter
Accessories	b/w: IR cut filter, IR pass filter color: protection glass
On request	Host adapter card, power out 6 W (HIROSE)
Software packages	API (FirePackage, Fire4Linux)

Table 18: Specification Guppy PRO F-146B/C

Note

The design and specifications for the products described above may change without notice.



Guppy PRO F-201B/C

Feature	Specification
Image device	Type 1/1.8 (diag. 8.9 mm) progressive scan SONY IT CCD ICX274AL/AQ with Super HAD microlens
Effective chip size	7.1 mm x 5.4 mm
Cell size	4.40 μm x 4.40 μm
Picture size (max.)	1624 x 1234 pixels (Format_7 Mode_0)
Lens mount	Adjustable C-Mount: 17.526 mm (in air); \varnothing 25.4 mm (32 tpi) maximum protrusion: 10.1 mm (see Figure 26: Guppy PRO C-Mount dimensions on page 68) Note Maximum protrusion means the distance from lens flange to the glass filter in the camera. 
ADC	12 bit
Color modes	Only color: Raw8, Raw12, Raw16, Mono8, YUV411, YUV422, RGB8
Frame rates	1.875 fps; 3.75 fps; 7.5 fps; 30 fps Up to 14 fps in Format_7
Gain control	Manual: 0-24.4 dB (0.0359 dB/step); auto gain (select. AOI)
Shutter speed	55 μs ... 67,108,864 μs (~ 67 s); auto shutter (select. AOI)
External trigger shutter	Programmable, trigger level control, single trigger, bulk trigger, programmable trigger delay
Look-up tables	User programmable (12 bit \rightarrow 10 bit); default gamma (0.45)
Smart functions	AGC (auto gain control), AEC (auto exposure control), autofunction AOI, LUT, binning (only b/w), sub-sampling (only b/w), color correction, hue, saturation, 1 storable user set only color: AWB (auto white balance)
I/Os	One configurable input (optocoupled), three configurable outputs (optocoupled)
Transfer rate	100 Mbit/s, 200 Mbit/s, 400 Mbit/s, 800 Mbit/s
Digital interface	IEEE 1394b (IIDC V1.31), 1 x copper connector
Power requirements	DC 8 V - 36 V via IEEE 1394 cable or 12-pin HIROSE
Power consumption	Typical <3.5 watt (@ 12 V DC) (full resolution and maximal frame rates)
Dimensions	44.8 mm x 29 mm x 29 mm (L x W x H); incl. connectors, without tripod and lens

Table 19: Specification Guppy PRO F-201B/C

Feature	Specification
Mass	75 g (without lens) + 5 g filter ring
Operating temperature	+ 5 °C ... + 45 °C ambient temperature (non-condensing)
Storage temperature	- 10 °C ... + 70 °C ambient temperature (non-condensing)
Regulations	CE, FCC Class B, RoHS (2002/95/EC)
Standard accessories	b/w: protection glass color: IR cut filter
Optional accessories	b/w: IR cut filter, IR pass filter color: protection glass
On request	Host adapter card, power out 6 W (HIROSE)
Software packages	API (FirePackage, Fire4Linux)

Table 19: Specification Guppy PRO F-201B/C

Note

The design and specifications for the products described above may change without notice.



Guppy PRO F-503B/C

Feature	Specification
Image device	Type 1/2.5 (diag. 7.13 mm) Micron/Aptina CMOS MT9P031 with microlens <ul style="list-style-type: none"> • Electronic rolling shutter (ERS) • Global reset release shutter (GRR)
Effective chip size	5.7 mm x 4.3 mm
Cell size	2.2 μm x 2.2 μm
Picture size (max.)	2588 x 1940 pixels (Format_7 Mode_0)
Lens mount	Adjustable C-Mount: 17.526 mm (in air); \varnothing 25.4 mm (32 tpi) maximum protrusion: 10.1 mm (see Figure 26: Guppy PRO C-Mount dimensions on page 68) <p>Note Maximum protrusion means the distance from lens flange to the glass filter in the camera.</p> 
ADC	12 bit
Color modes	Only color: Raw8, Raw12, Raw16, Mono8/12/16 (all F7 modes), YUV411 (all F7 modes), YUV422 (all F7 modes)
Frame rates	1.875 fps; 3.75 fps; 7.5 fps; 15 fps; 30 fps; 60 fps; 120 fps variable frame rates in Format_7 up to 13 fps at full resolution (up to ~ 830 fps at 64x64)
Gain control	Manual: 0 ... 12.04 dB (~0.125/step (1.02 - 0.28 dB/step)) 12.57 ... 18.06 dB (~0.5/step (0.53 - 0.28 dB/step)) Auto gain (select. AOI)
Shutter speed	20 μs ... ~ 22.37 s
External trigger shutter	Edge mode, programmable trigger delay
Look-up tables	User programmable (12 bit \rightarrow 10 bit); default gamma (0.45)
Smart functions	AGC (auto gain control), AEC (auto exposure control), autofunction AOI, LUT, mirror, binning, low-noise binning mode, sub-sampling, defect pixel correction, color correction, hue, saturation, 1 storable user set only color: AWB (auto white balance)
I/Os	One configurable input (optocoupled), three configurable outputs (optocoupled)
Transfer rate	100 Mbit/s, 200 Mbit/s, 400 Mbit/s, 800 Mbit/s

Table 20: Specification Guppy PRO F-503B/C

Feature	Specification
Digital interface	IEEE 1394b (IIDC V1.31), 1 x copper connector
Power requirements	DC 8 V - 36 V via IEEE 1394 cable or 8-pin HIROSE
Power consumption	Typical <3.5 watt (@ 12 V DC) (full resolution and maximal frame rates)
Dimensions	44.8 mm x 29 mm x 29 mm (L x W x H); incl. connectors, without tripod and lens
Mass	75 g (without lens) + 5 g filter ring
Operating temperature	+ 5 °C ... + 45 °C ambient temperature (non-condensing)
Storage temperature	- 10 °C ... + 70 °C ambient temperature (non-condensing)
Regulations	FCC Class B, CE, RoHS (2002/95/EC)
Standard accessories	b/w: protection glass color: IR cut filter
Optional accessories	b/w: IR cut filter, IR pass filter color: protection glass
On request	Host adapter card, power out 6 W (HIROSE)
Software packages	API (FirePackage, Fire4Linux)

Table 20: Specification Guppy PRO F-503B/C

Note

The design and specifications for the products described above may change without notice.



Spectral sensitivity

Note



All measurements were done without protection glass / without filter.

The uncertainty in measurement of the QE values is $\pm 10\%$.
(QE = Quantum Efficiency)

This is due to:

- Manufacturing tolerance of the sensor
- Uncertainties in the measuring apparatus itself (Ulbricht-Kugel/Ulbricht sphere, optometer, etc.)

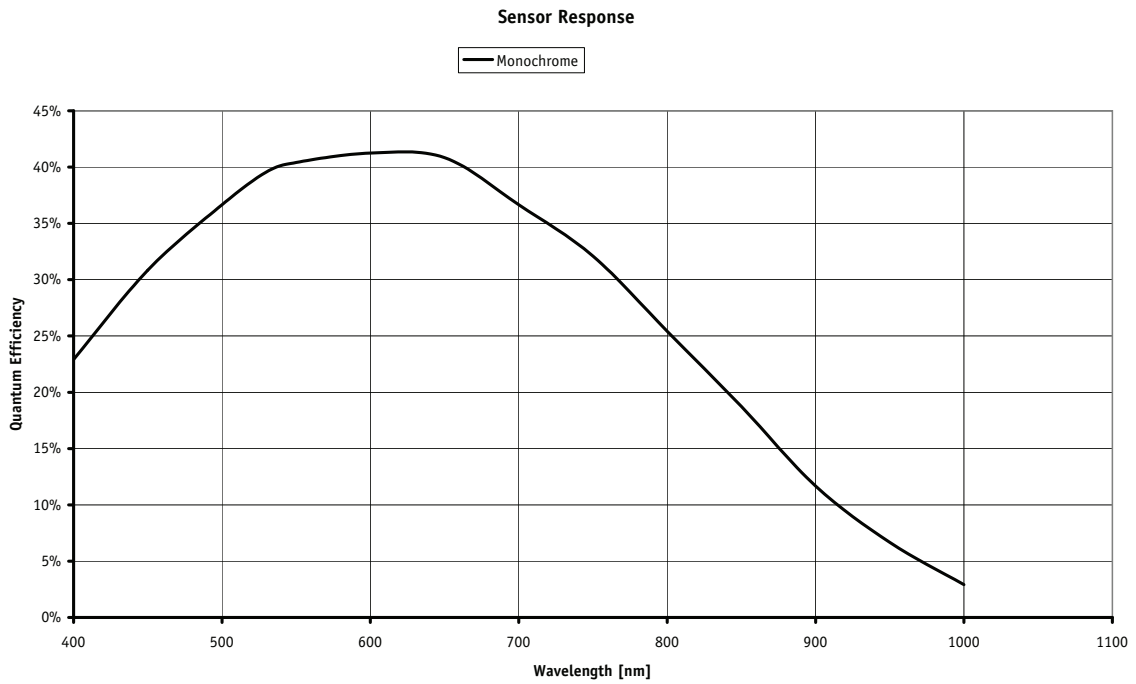

Figure 7: Spectral sensitivity of Guppy PRO F-031B

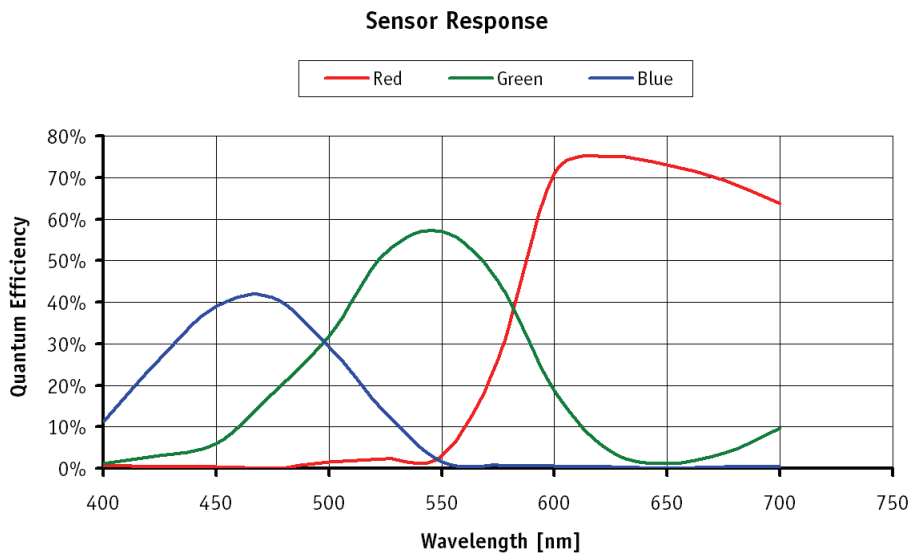

Figure 8: Spectral sensitivity of Guppy PRO F-031C (without IR cut filter)

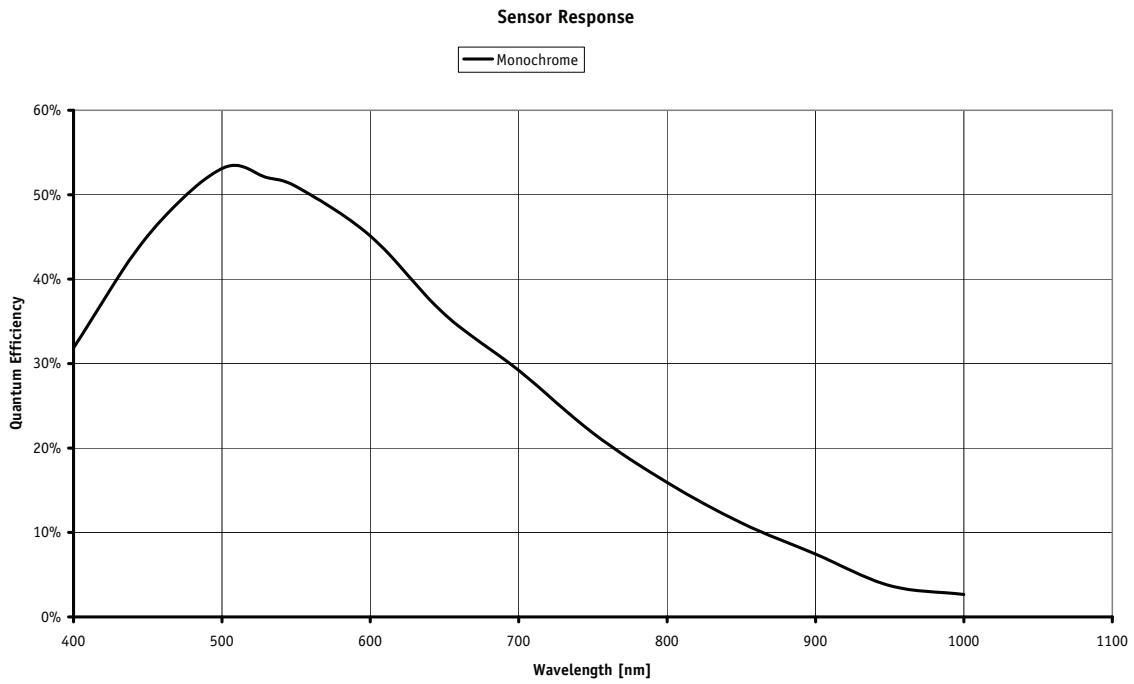

Figure 9: Spectral sensitivity of Guppy PRO F-032B

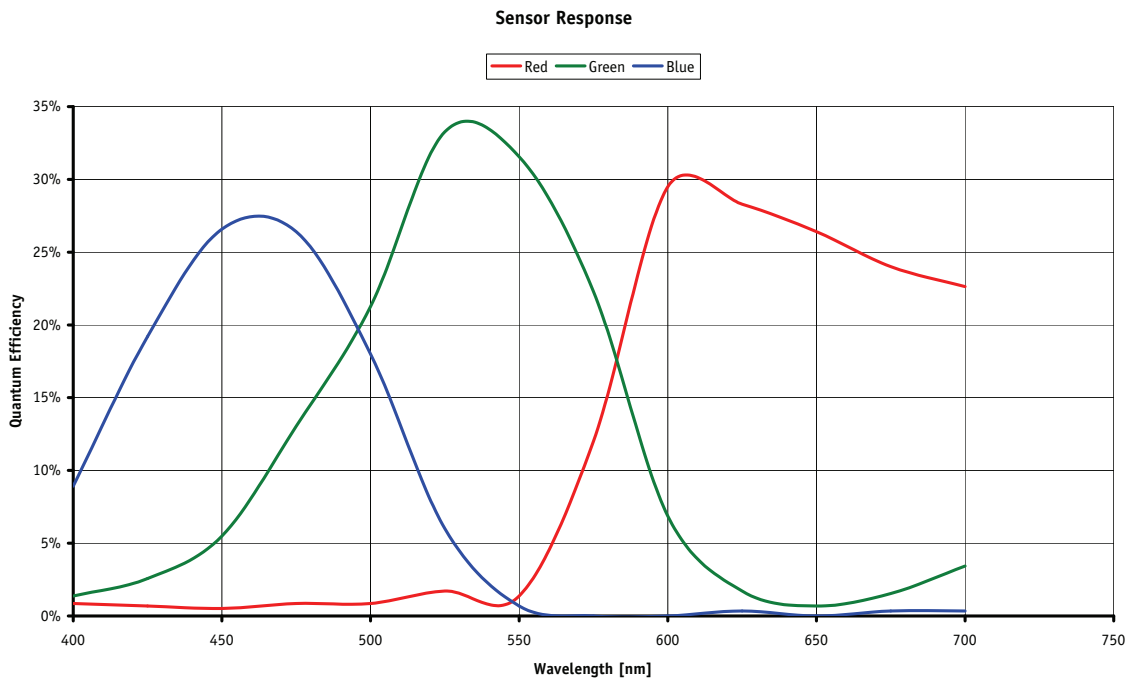

Figure 10: Spectral sensitivity of Guppy PRO F-032C (without IR cut filter)

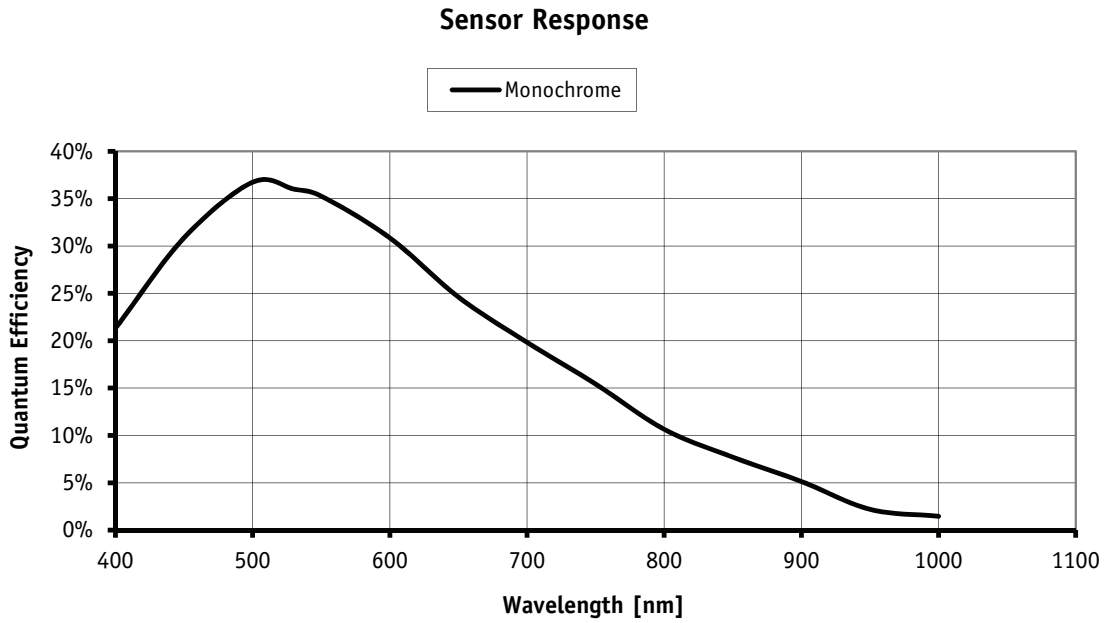

Figure 11: Spectral sensitivity of Guppy PRO F-033B

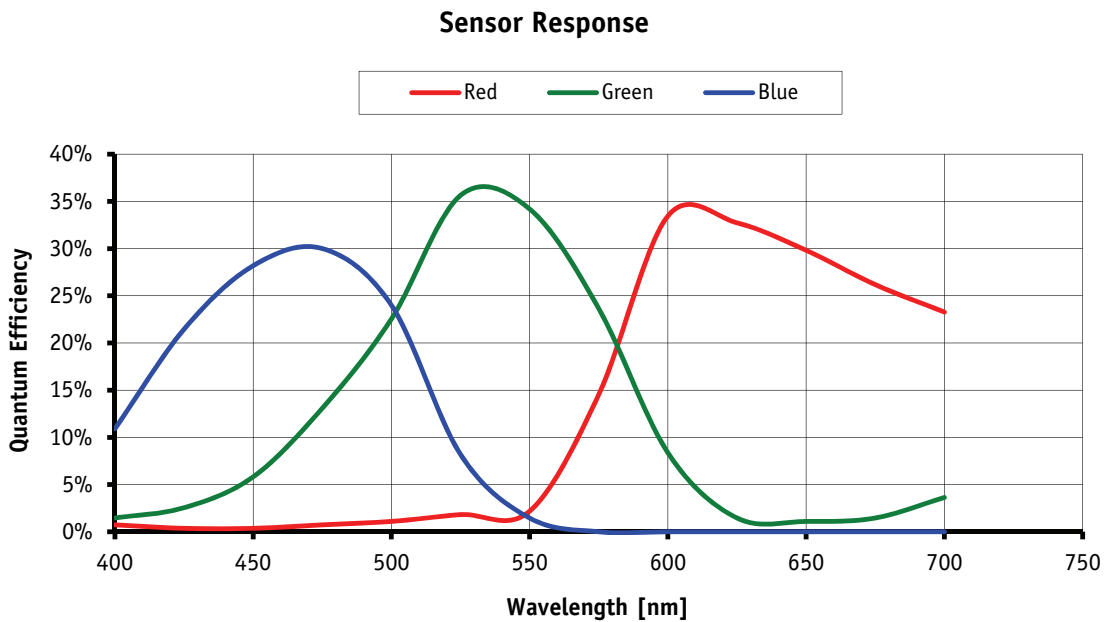

Figure 12: Spectral sensitivity of Guppy PRO F-033C (without IR cut filter)

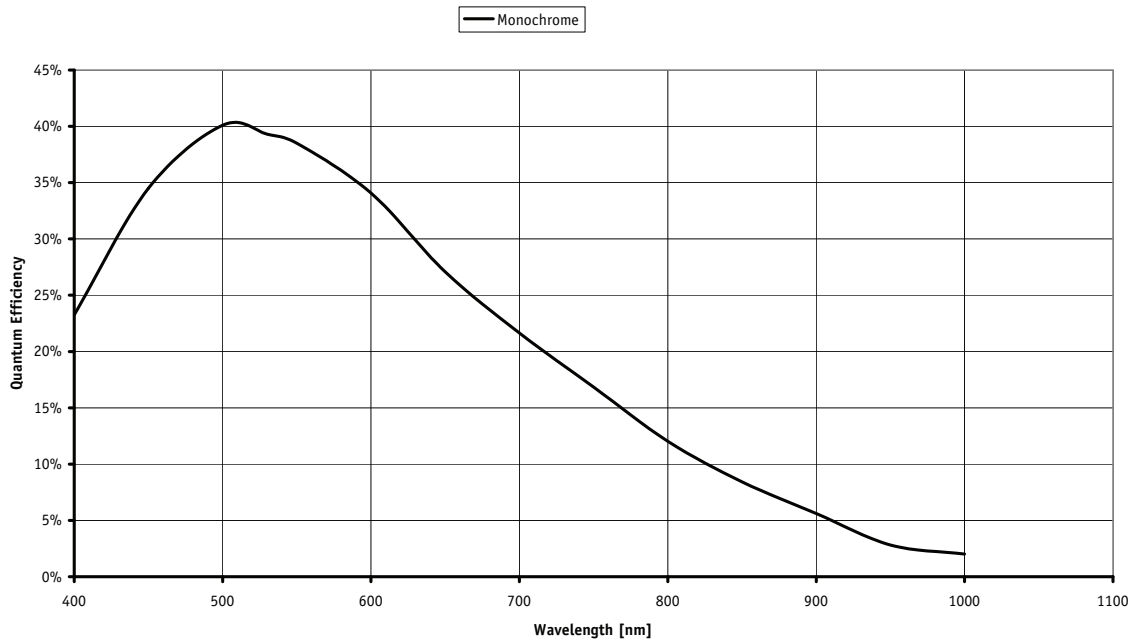

Figure 13: Spectral sensitivity of Guppy PRO F-046B

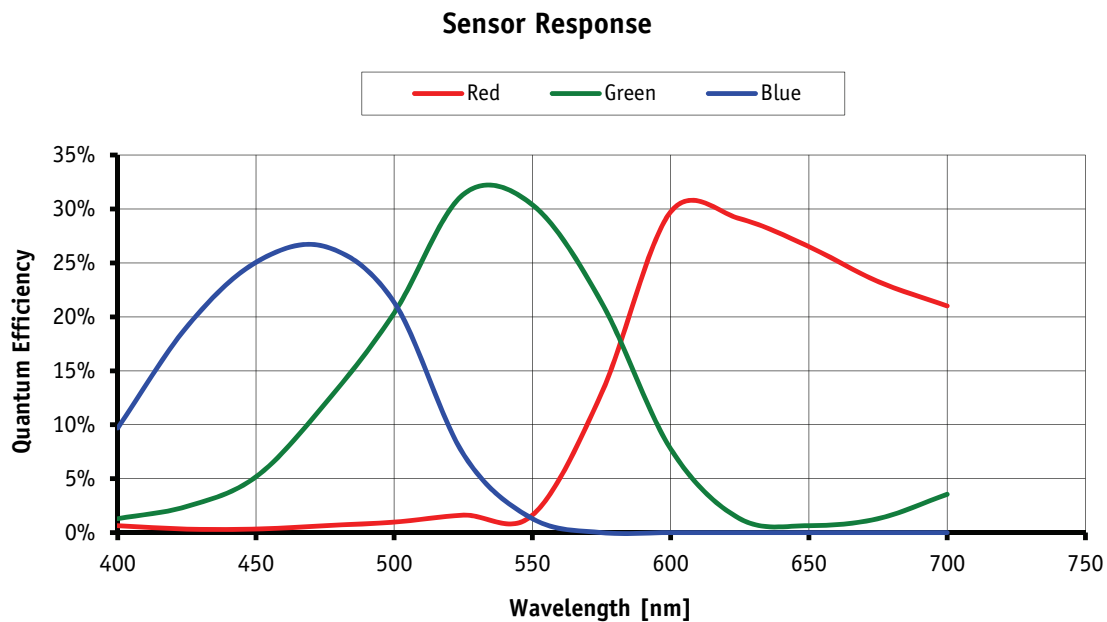

Figure 14: Spectral sensitivity of Guppy PRO F-046C (without IR cut filter)

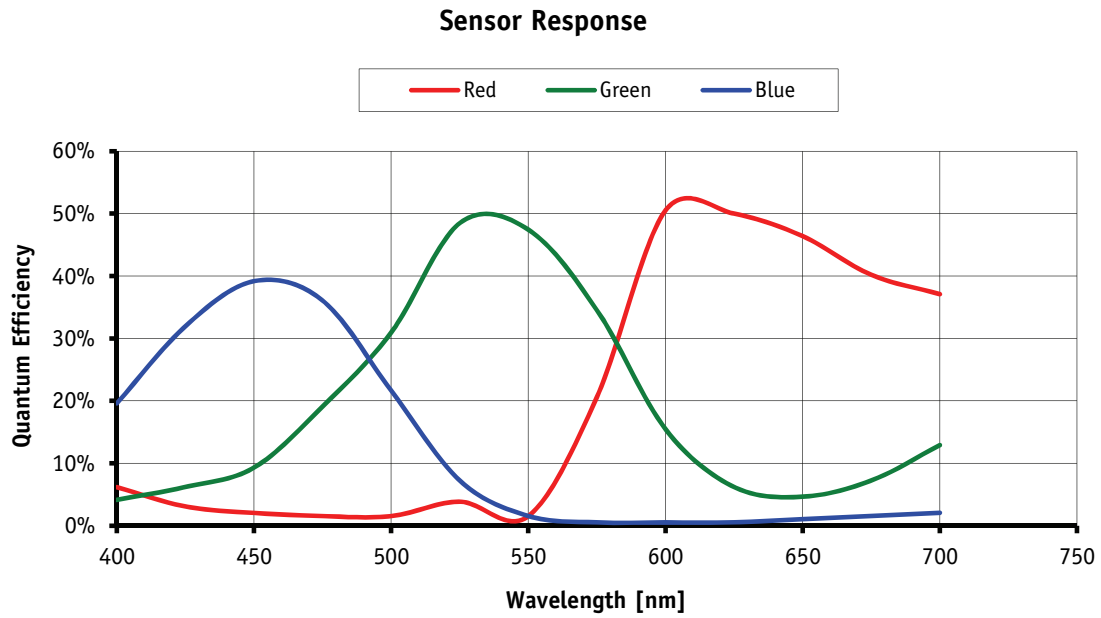

Figure 15: Spectral sensitivity of Guppy PRO F-095C (without IR cut filter)

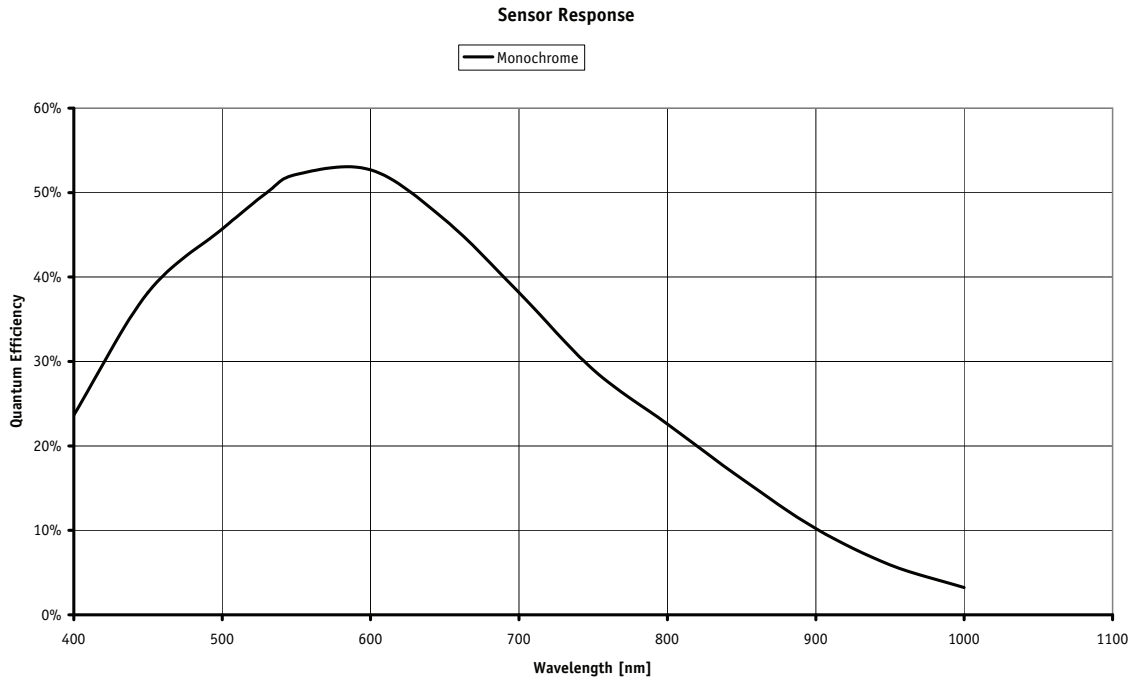

Figure 16: Spectral sensitivity of Guppy PRO F-125B

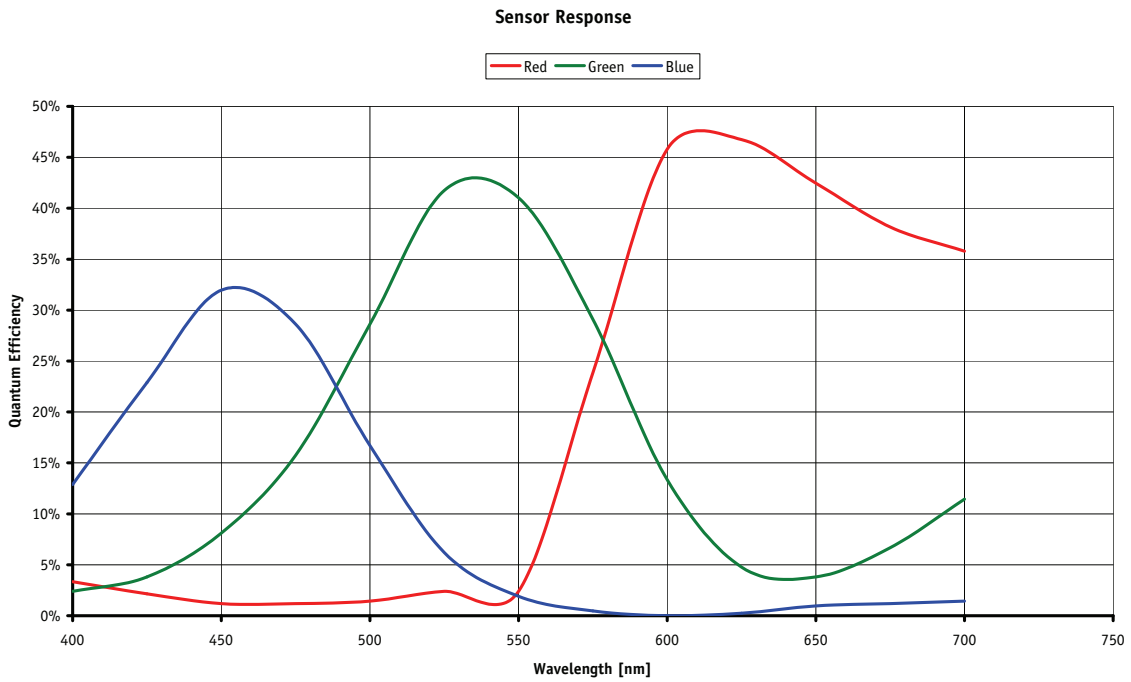

Figure 17: Spectral sensitivity of Guppy PRO F-125C (without IR cut filter)

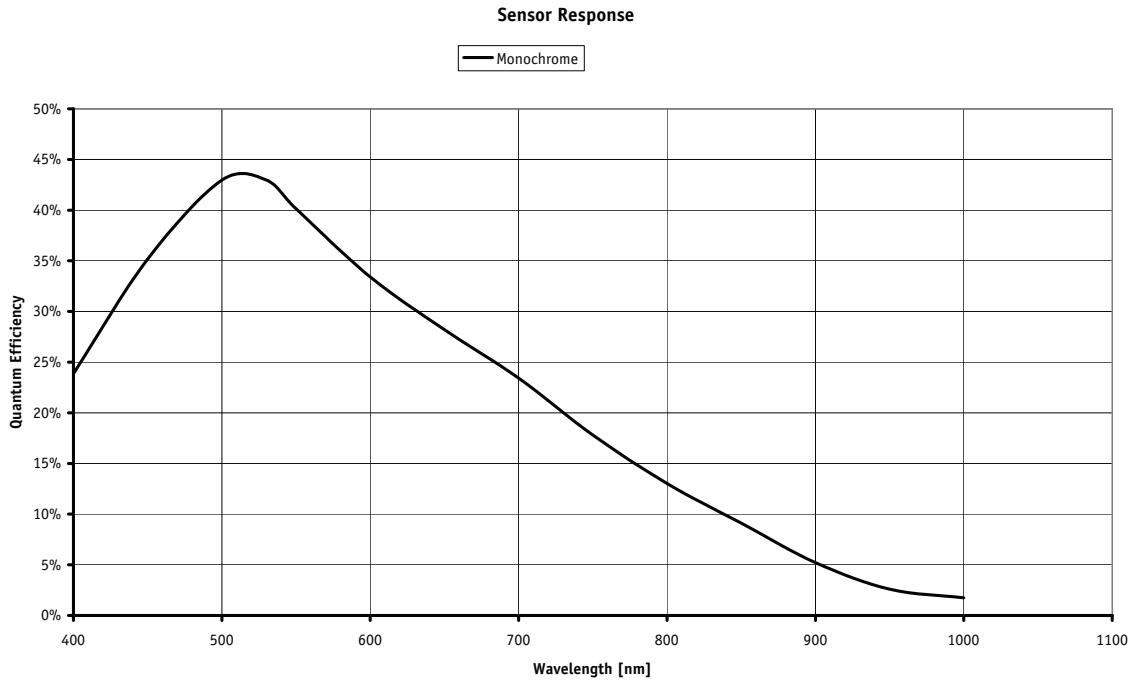

Figure 18: Spectral sensitivity of Guppy PRO F-146B

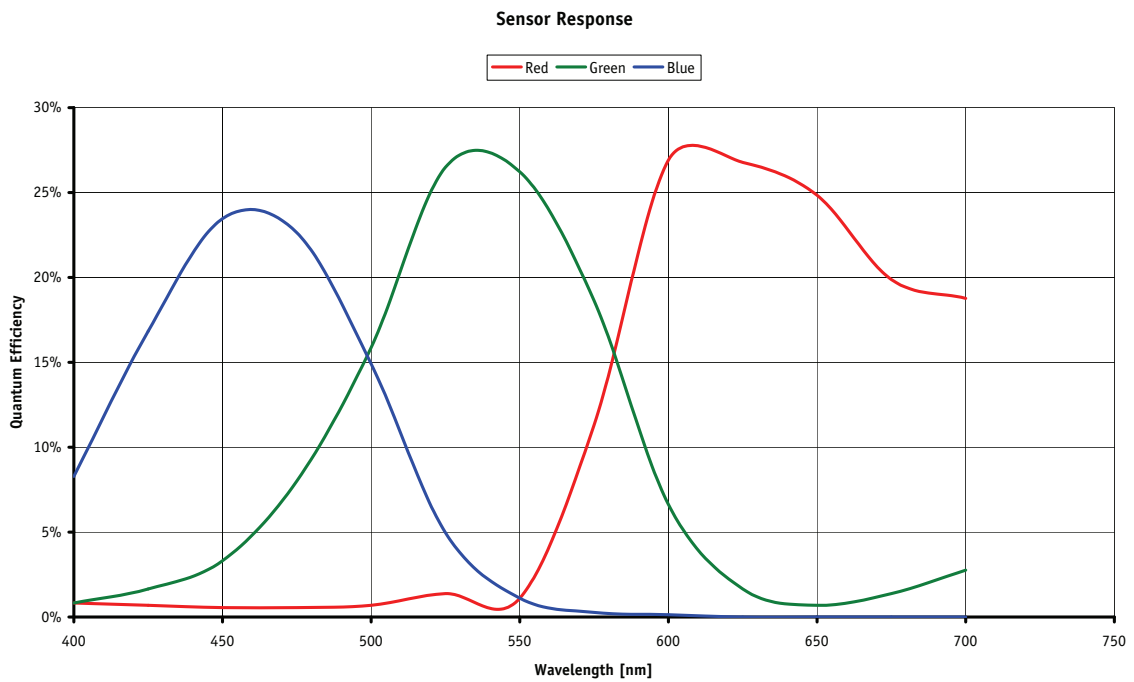

Figure 19: Spectral sensitivity of Guppy PRO F-146C (without IR cut filter)

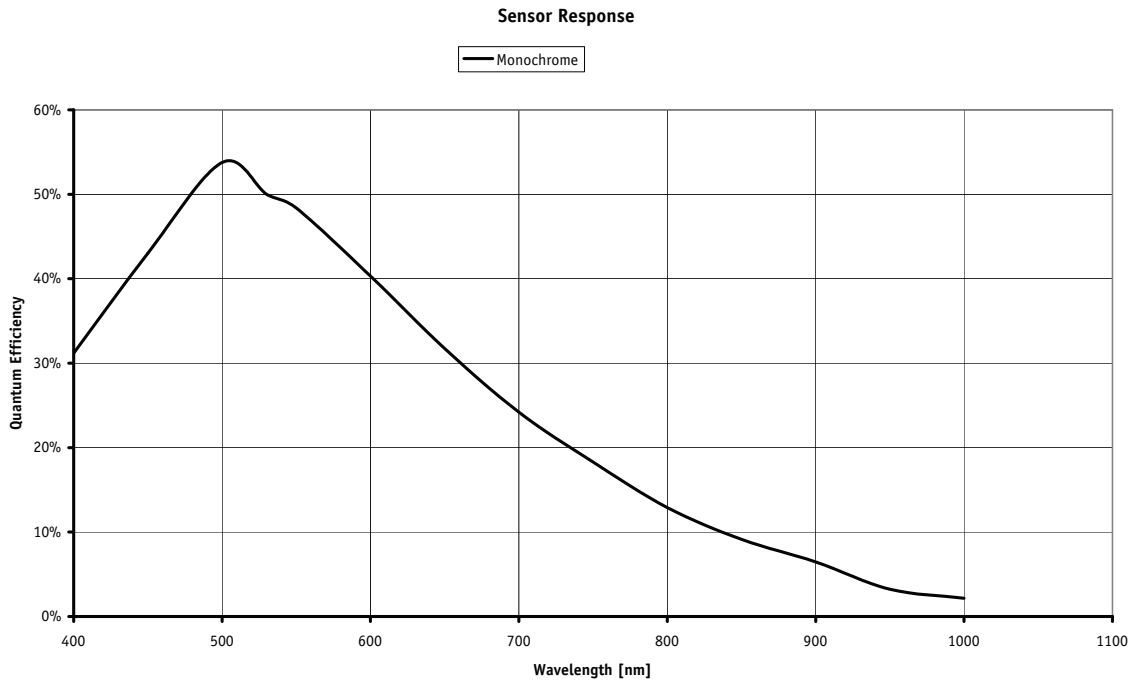

Figure 20: Spectral sensitivity of Guppy PRO F-201B

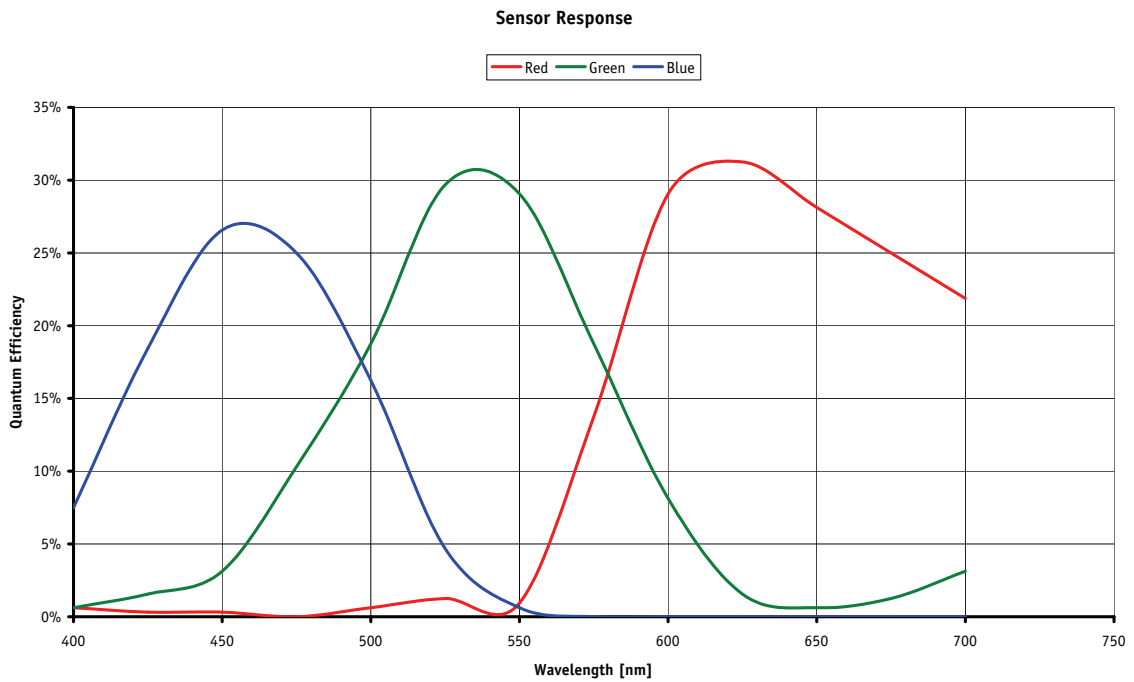

Figure 21: Spectral sensitivity of Guppy PRO F-201C (without IR cut filter)

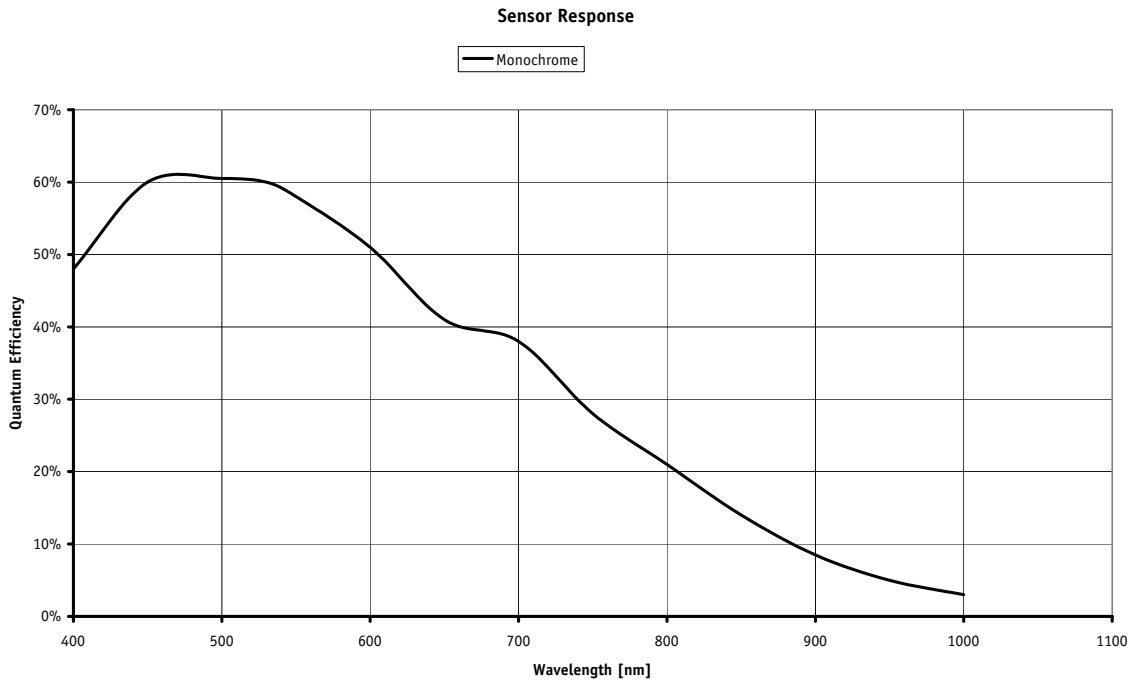

Figure 22: Spectral sensitivity of Guppy PRO F-503B

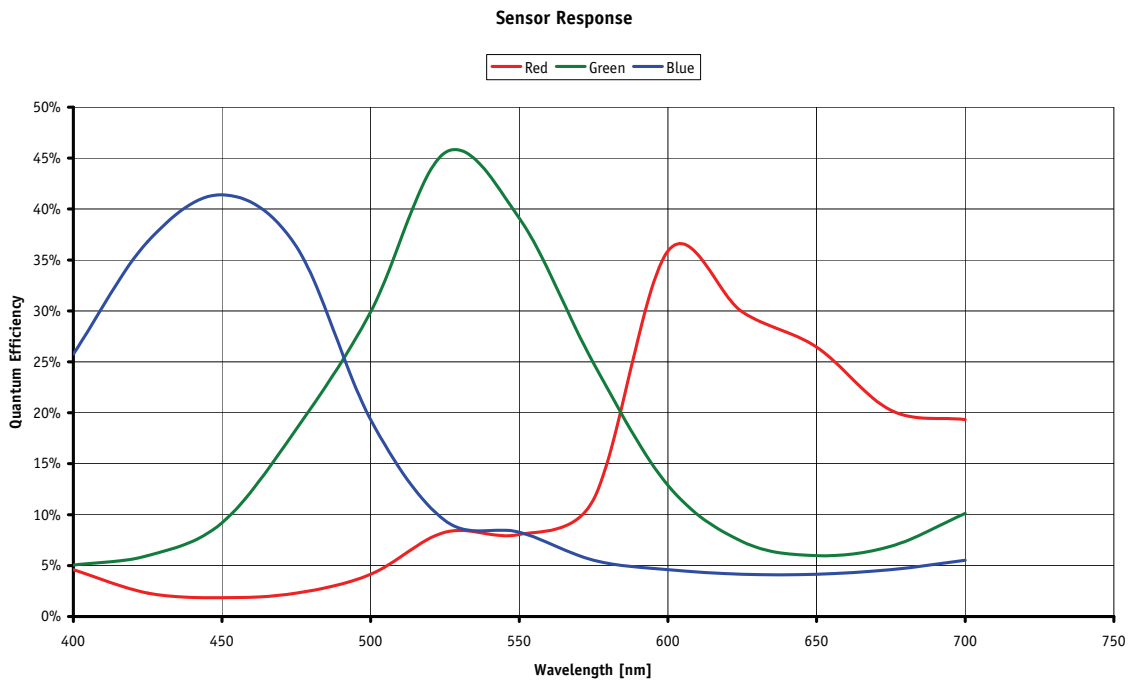

Figure 23: Spectral sensitivity of Guppy PRO F-503C (without IR cut filter)

Camera dimensions

Note



For information on **sensor position accuracy**:

(sensor shift x/y, optical back focal length z and sensor rotation α) see Chapter [Sensor position accuracy of AVT Guppy PRO cameras](#) on page 272.

Guppy PRO standard housing (1 x 1394b copper)

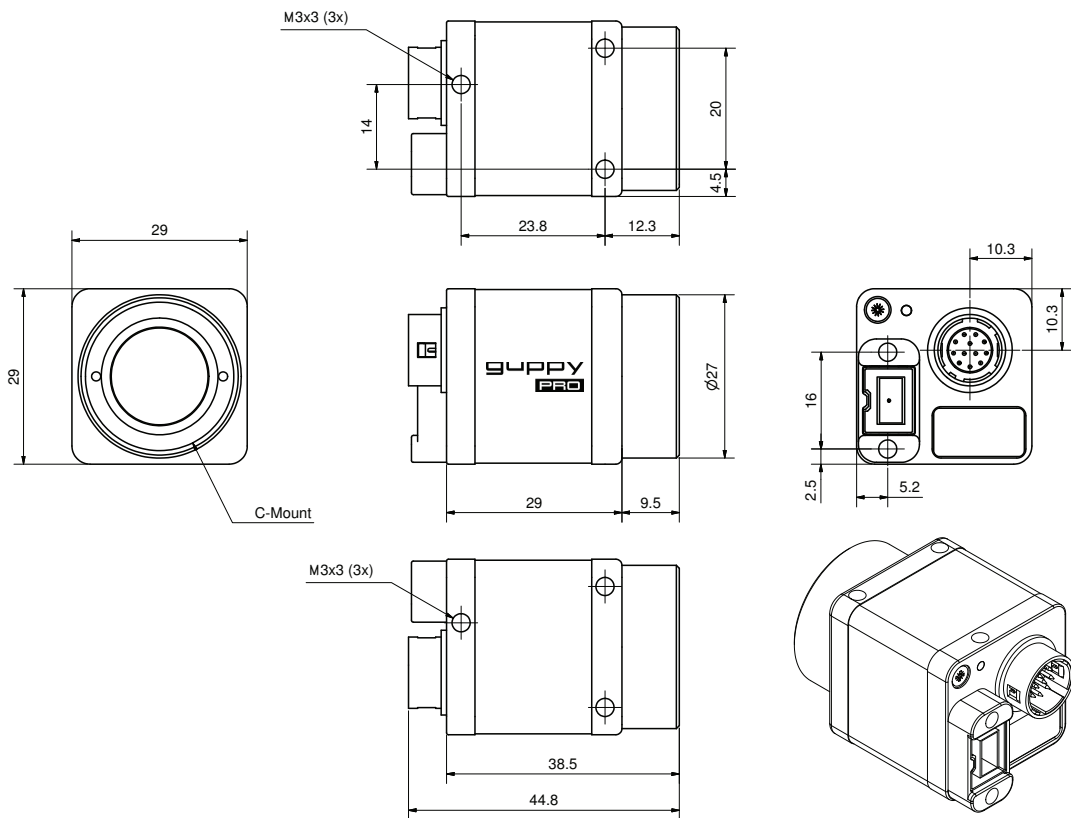
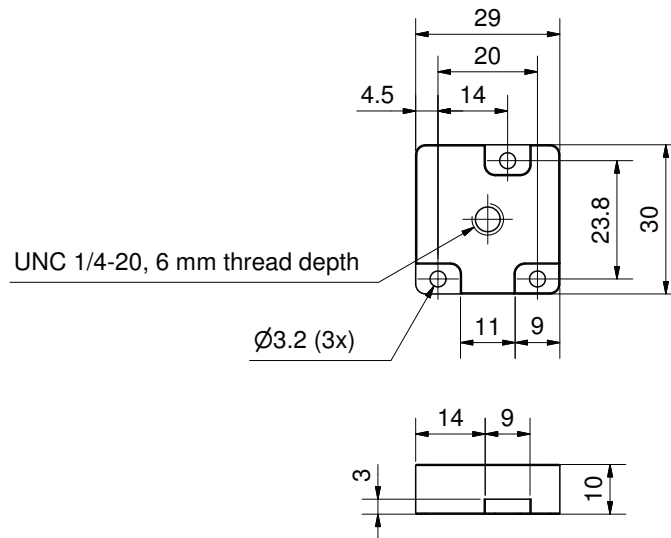

Figure 24: Camera dimensions (1 x 1394b copper)

Tripod adapter

This three hole tripod adapter (AVT order number 1216) ...

- ... can be used for Guppy PRO only.
- ... is only designed for standard housings.



Body size: 29 mm x 30 mm x 10 mm (L x W x H)

Figure 25: Tripod dimensions

Cross section: C-Mount

- All **monochrome** Guppy PRO cameras are equipped with the same model of protection glass.
- All **color** Guppy PRO cameras are equipped with the same model of IR cut filter.

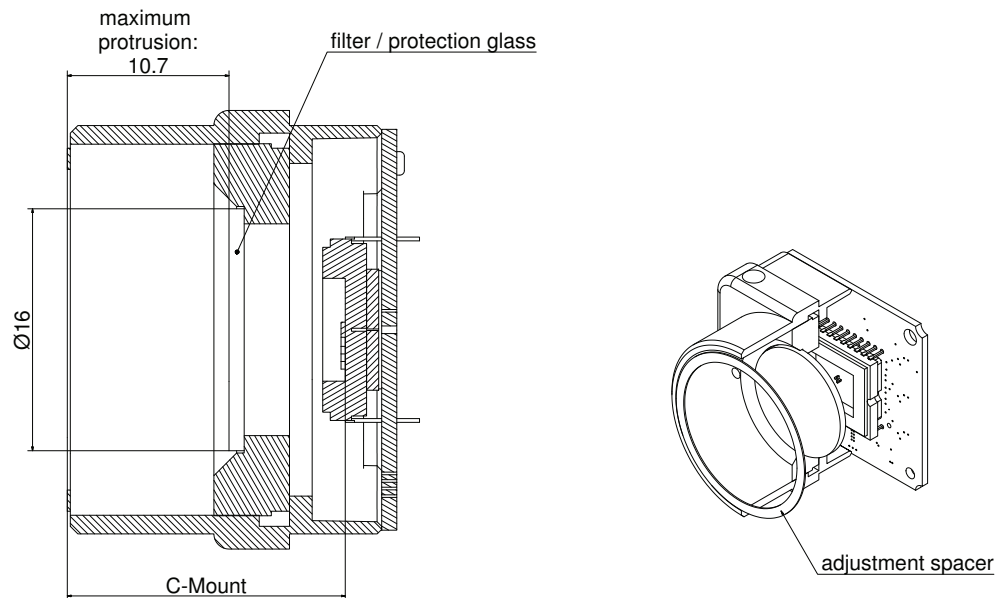

Figure 26: Guppy PRO C-Mount dimensions

Note



Adjustment is only done (via adjustment spacer between lens and front flange), if the customer needs accuracy below 100 μm .

For more information read Chapter [Adjustment of C-Mount](#) on page 69.

Adjustment of C-Mount

The dimensional adjustment cannot be done any more by the customer. All adjustments have to be done by the AVT factory.

Adjustment is only done (via adjustment spacer between lens and front flange), if the customer needs accuracy below 100 μm .

If you need any adjustments, please contact Customer Care: For phone numbers and e-mail: See Chapter [Contacting Allied Vision Technologies](#) on page 9.

Note



For all customers who know the C-Mount adjustment procedure from Pike and Oscar cameras:

The front flange of Guppy PRO cameras is a fixed part of the camera (and cannot be screwed).

As mentioned above: **adjustment** of C-Mount with **Guppy PRO** cameras **can only be done by the AVT factory.**

Camera interfaces

This chapter gives you detailed information on status LEDs, inputs and outputs, trigger features and transmission of data packets.

Note



For a detailed description of the **camera interfaces (FireWire, I/O connector)**, and **operating instructions** see the **Hardware Installation Guide**, Chapter *Camera interfaces*.

Read all **Notes** and **Cautions** in the **Hardware Installation Guide**, before using any interfaces.

IEEE 1394b port pin assignment

The IEEE 1394b connector is designed for industrial use and has the following pin assignment as per specification:

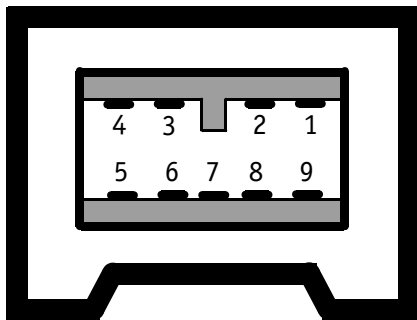

Pin	Signal
1	TPB-
2	TPB+
3	TPA-
4	TPA+
5	TPA (Reference ground)
6	VG (GND)
7	N.C.
8	VP (Power, VCC)
9	TPB (Reference ground)

Figure 27: IEEE 1394b connector

Note



- IEEE 1394b connectors with **screw lock** mechanism provide access to the IEEE 1394 bus and thus makes it possible to control the camera and output frames.

www



For **more information on cables** and on **ordering cables online** (by clicking the article and sending an inquiry) go to:

<http://www.alliedvisiontec.com/emea/products/accessories/firewire-accessories.html>

Camera I/O connector pin assignment

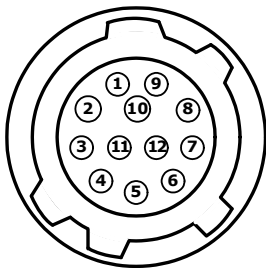

Pin	Signal	Direction	Level	Description
1	External GND		GND for ext. power	External Ground for external power
2	External Power		+8...+36 V DC	Power supply
3	---	---	---	---
4	Camera In 1	In	$U_{in}(high) = 3 V...24 V$ $U_{in}(low) = 0 V...1.5 V$	Camera Input 1 (GPIn1) default: Trigger
5	Camera Out 3	Out	Open emitter,	Camera Output 3 (GPOut3) default: Busy
6	Camera Out 1	Out	Open emitter	Camera Output 1 (GPOut1) default: IntEna
7	Camera In GND	In	Common GND for inputs	Camera Common Input Ground (In GND)
8	---	---	---	---
9	---	---	---	---
10	Camera Out Power	In	Common VCC for outputs max. 36 V DC	External Power for digital outputs (OutVCC)
11	---	---	---	---
12	Camera Out 2	Out	Open emitter	Camera Output 2 (GPOut2) default: Off

Figure 28: Camera I/O connector pin assignment

Note**GP = General Purpose**

For a detailed description of the **I/O connector and its operating instructions** see the **Hardware Installation Guide, Chapter Guppy PRO input description**.

Read all **Notes** and **Cautions** in the **Hardware Installation Guide**, before using the I/O connector.

Status LEDs

1 status LED bicolor



Figure 29: Position of status LED (example showing green half of LED on)

There is one **bicolor** LED: showing green or orange (If half **green** and half **red** is on you see an **orange** color).

RED means: red half of LED permanent on

+RED pulsing means: red half of LED is switched on for a short time. If the red LED is already on, the LED will be switched off.

GREEN means: green half of LED permanent on

+GREEN pulsing means: green half of LED is switched on for a short time. If the green LED is already on, the LED will be switched off.

Normal conditions

Event	(GREEN)	(RED)
Camera startup	During startup all LEDs are switched on consecutively to show the startup progress: (GREEN + RED) long time then (GREEN + RED) short time then GREEN permanent on	
Power on	GREEN	
Bus reset	not available	
Asynchronous traffic	+GREEN pulsing	
Isochronous traffic	+GREEN pulsing	
Waiting for external trigger	GREEN	RED
External trigger event	GREEN	+RED pulsing

Table 21: LEDs showing normal conditions

Error conditions

Blink codes are used to signal warnings or error states (When S1 and S2 blink together, you see blinking orange):

- S1 means green half of LED
- S2 means red half of LED
- Example: LLC not ready ⇒ S1 (3 blinks) + S2 (5 blinks): 3 orange blinks and afterwards 2 red blinks

Error Code S1 →	1 blink	2 blinks	3 blinks	4 blinks	5 blinks	6 blinks	7 blinks
Error Class S2 ↓							
1 blink	Video mode error	Format 7 error 1	Format 7 error 2				
2 blinks	Camera class object	Camera regconst object	Register mapping	Unknown FPGA type ID			
3 blinks	FLASH class object	Platform class object	Platform initialization	Platform firmware set	Platform LLC version		
4 blinks	FPGA boot S1 error	FPGA boot S2 error	FPGA boot S3 error	FPGA boot S4 error	FPGA boot S5 error		FPGA version not supported
5 blinks	Stack setup error	Stack start error	LLC not ready				
6 blinks							
7 blinks							
8 blinks	No valid firmware set available						

Table 22: Error codes

Video mode error: These are error modes according IIDC specification: Vmode_Error_Status register (wrong settings of video mode, format, frame rate and ISO settings).

Format 7 error: see Format 7 register description of IIDC specification.

Control and video data signals

The inputs and outputs of the camera can be configured by software. The different modes are described below.

Inputs

Note



For a general description of the **inputs** and **warnings** see the **Hardware Installation Guide**, Chapter **Guppy PRO input description**.

The optocoupler inverts all input signals. Inversion of the signal is controlled via the IO_INP_CTRL1..2 register (see [Table 23: Advanced register: Input control](#) on page 76).

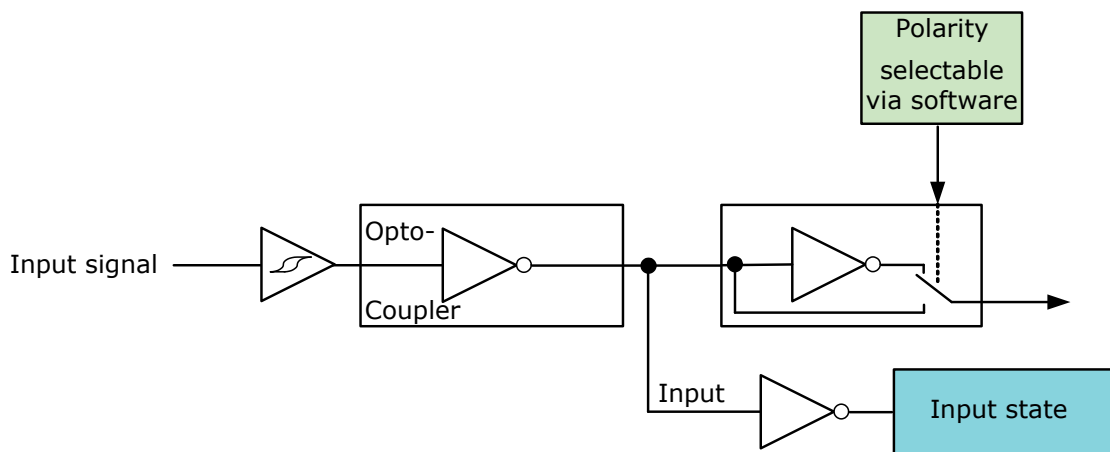

Figure 30: Input block diagram

Triggers

All inputs configured as triggers are linked by AND. If several inputs are being used as triggers, a high signal must be present on all inputs in order to generate a trigger signal. Each signal can be inverted. The camera must be set to **external triggering** to trigger image capture by the trigger signal.

Input/output pin control

All input and output signals running over the camera I/O connector are controlled by an advanced feature register.

Register	Name	Field	Bit	Description
0xF100300	IO_INP_CTRL1	Presence_Inq	[0]	Indicates presence of this feature (read only)
		---	[1..6]	Reserved
		Polarity	[7]	0: Signal not inverted 1: Signal inverted
		---	[8..10]	Reserved
		InputMode	[11..15]	Mode see Table 24: Input routing on page 77
		---	[16..30]	Reserved
		PinState	[31]	RD: Current state of pin

Table 23: Advanced register: **Input control**

IO_INP_CTRL 1

The **Polarity** flag determines whether the input is low active (0) or high active (1). The **input mode** can be seen in the following table. The **PinState** flag is used to query the current status of the input.

The **PinState** bit reads the inverting optocoupler status after an internal negation. See [Figure 30: Input block diagram](#) on page 75.

This means that an open input sets the **PinState** bit to **0**. (This is different to AVT Marlin/Dolphin/Oscar, where an open input sets **PinState** bit to **1**.)

ID	Mode	Default
0x00	Off	
0x01	Reserved	
0x02	Trigger input	Input 1
0x03..0x1F	Reserved	

Table 24: Input routing

Note If you set more than 1 input to function as a trigger input, all trigger inputs are ANDed.



Trigger delay

Guppy PRO cameras feature various ways to delay image capture based on external trigger.

With IIDC V1.31 there is a standard CSR at Register F0F00534/834h to control a delay up to FFFh x time base value.

The following table explains the inquiry register and the meaning of the various bits.

Register	Name	Field	Bit	Description
0xF0F00534	TRIGGER_DELAY_INQUIRY	Presence_Inq	[0]	Indicates presence of this feature (read only)
		Abs_Control_Inq	[1]	Capability of control with absolute value
		---	[2]	Reserved
		One_Push_Inq	[3]	One-push auto mode (controlled automatically by the camera once)
		Readout_Inq	[4]	Capability of reading out the value of this feature
		ON_OFF	[5]	Capability of switching this feature ON and OFF
		Auto_Inq	[6]	Auto mode (controlled automatically by the camera)
		Manual_Inq	[7]	Manual mode (controlled by user)
		Min_Value	[8..19]	Minimum value for this feature
		Max_Value	[20..31]	Maximum value for this feature

Table 25: Trigger delay inquiry register

Register	Name	Field	Bit	Description
0xF0F00834	TRIGGER_DELAY	Presence_Inq	[0]	Presence of this feature: 0: N/A 1: Available
		Abs_Control	[1]	Absolute value control 0: Control with value in the value field 1: Control with value in the absolute value CSR. If this bit=1 the value in the value field has to be ignored.
		---	[2..5]	Reserved
		ON_OFF	[6]	Write ON or OFF this feature Read: Status of the feature ON=1 OFF=0
		---	[7..19]	Reserved
		Value	[20..31]	Value

Table 26: Trigger Delay CSR

The cameras also have an advanced register which allows even more precise image capture delay after receiving a hardware trigger.

Trigger delay advanced register

Register	Name	Field	Bit	Description
0xF1000400	TRIGGER_DELAY	Presence_Inq	[0]	Indicates presence of this feature (read only)
		---	[1..5]	Reserved
		ON_OFF	[6]	Trigger delay on/off
		---	[7..10]	Reserved
		DelayTime	[11..31]	Delay time in μs

Table 27: Trigger delay advanced CSR

The advanced register allows the start of the integration to be delayed by max. $2^{21} \mu\text{s}$, which is max. 2.1 s after a trigger edge was detected.

Note



- Switching trigger delay to ON also switches external Trigger_Mode_0 to ON.
- This feature works with external Trigger_Mode_0 only.

Outputs

Note



For a general description of the **outputs** and **warnings** see the **Hardware Installation Guide**, Chapter **Guppy PRO output description**.

Output features are configured by software. Any signal can be placed on any output.

The main features of output signals are described below:

Signal	Description
IntEna (Integration Enable) signal	This signal displays the time in which exposure was made. By using a register this output can be delayed by up to 1.05 seconds.
Fval (Frame valid) signal	This feature signals readout from the sensor. This signal Fval follows IntEna.
Busy signal	This signal appears when: <ul style="list-style-type: none"> • the exposure is being made or • the sensor is being read out or • data transmission is active. The camera is busy.
PulseWidthMod (pulse-width modulation) signal	Each output has pulse-width modulation (PWM) capabilities, which can be used for motorized speed control or autofocus control. See Chapter Pulse-width modulation on page 85ff.
WaitingForTrigger signal	This signal is available and useful for the outputs in Trigger Edge Mode . (In level mode it is available but useless, because exposure time is unknown. (Signal always =0)) In edge mode it is useful to know if the camera can accept a new trigger (without overtriggering). See Table 30: Output routing on page 83 and Figure 32: Output impulse diagram on page 84

Table 28: Output signals

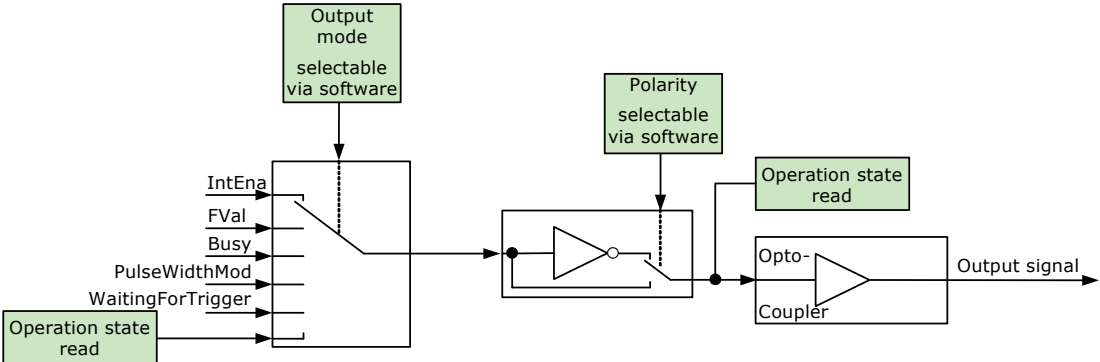

Figure 31: Output block diagram

IO_OUTP_CTRL 1-3

The outputs (Output mode, Polarity) are controlled via 3 advanced feature registers (see [Table 29: Advanced register: Output control](#) on page 82).

The **Polarity** field determines whether the output is inverted or not. The **output mode** can be viewed in the table below. The current status of the output can be queried and set via the **PinState**.

It is possible to read back the status of an output pin regardless of the output mode. This allows for example the host computer to determine if the camera is busy by simply polling the BUSY output.

Note Outputs in **Direct Mode**:



For correct functionality the **Polarity should always be set to 0** (SmartView: Trig/IO tab, Invert=No).

Register	Name	Field	Bit	Description
0xF1000320	IO_OUTP_CTRL1	Presence_Inq	[0]	Indicates presence of this feature (read only)
		PWMCapable	[1]	All Guppy PRO cameras: Indicates if an output pin supports the PWM feature. See Table 31: PWM configuration registers on page 85.
		---	[2..6]	Reserved
		Polarity	[7]	0: Signal not inverted 1: Signal inverted
		---	[8..10]	Reserved
		Output mode	[11..15]	Mode see Table 30: Output routing on page 83
		---	[16..30]	Reserved
		PinState	[31]	RD: Current state of pin WR: New state of pin
0xF1000324	IO_OUTP_CTRL2	Same as IO_OUTP_CTRL1		
0xF1000328	IO_OUTP_CTRL3	Same as IO_OUTP_CTRL1		

Table 29: Advanced register: **Output control**

Output modes

ID	Mode	Default / description
0x00	Off	
0x01	Output state follows PinState bit	Using this mode, the Polarity bit has to be set to 0 (not inverted). This is necessary for an error free display of the output status.
0x02	Integration enable	Output 1
0x03	Reserved	
0x04	Reserved	
0x05	Reserved	
0x06	FrameValid	
0x07	Busy	Output 2
0x08	Follow corresponding input (Inp1 → Out1, Inp2 → Out2)	
0x09	PWM (=pulse-width modulation)	Guppy PRO housing models
0x0A	WaitingForTrigger	Only in Trigger Edge Mode . All other Mode = 0 WaitingForTrigger is useful to know, if a new trigger will be accepted.
0x0B..0x1F	Reserved	

Table 30: Output routing

PinState 0 switches off the output transistor and produces a low level over the resistor connected from the output to ground.

The following diagram illustrates the dependencies of the various output signals.

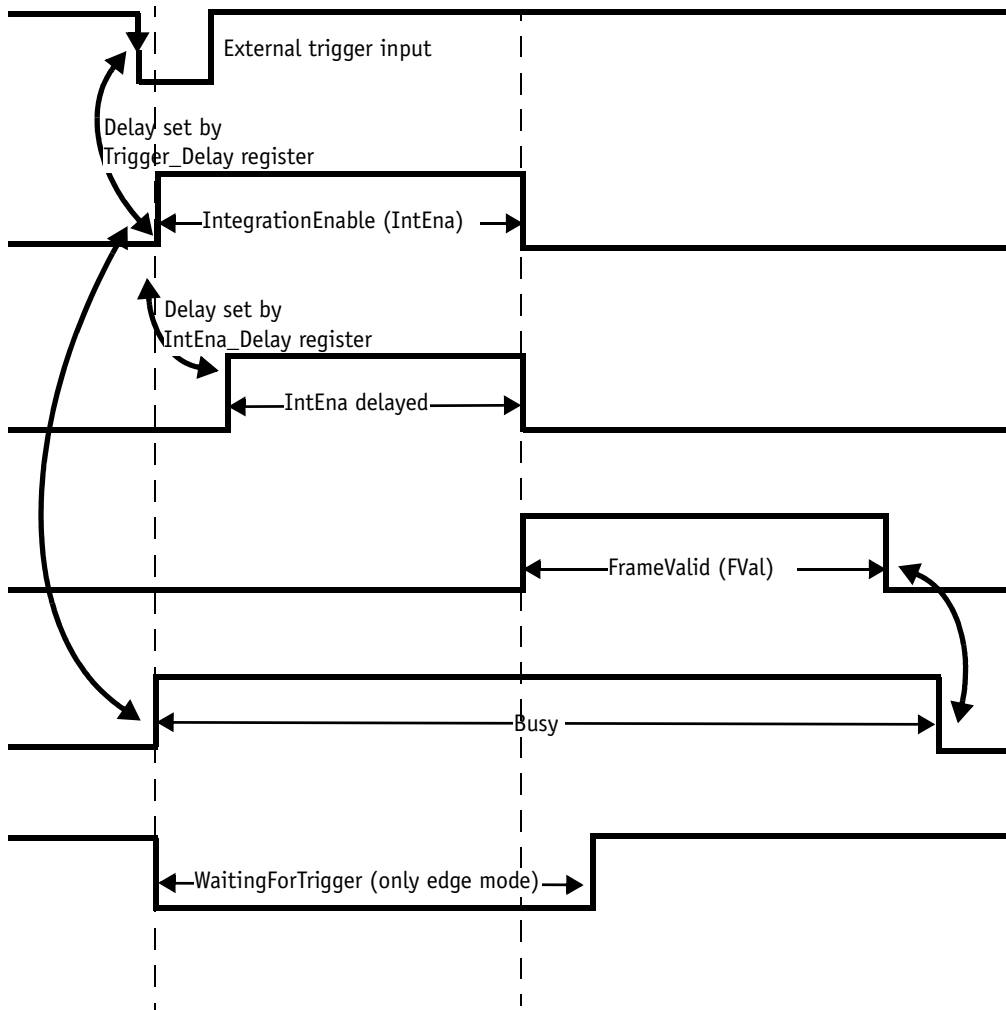

Figure 32: Output impulse diagram

Note The signals can be inverted.



Caution Firing a new trigger while **IntEna** is still active can result in missing image.



Note



- Note that **trigger delay** in fact delays the image capture whereas the **IntEna_Delay** only delays the leading edge of the IntEna output signal but does not delay the image capture.
- As mentioned before, it is possible to set the outputs by software. Doing so, the achievable maximum frequency is strongly dependent on individual software capabilities. As a rule of thumb, the camera itself will limit the toggle frequency to not more than 700 Hz.

Pulse-width modulation

The 1 input and 3 outputs are independent. Each output has pulse-width modulation (PWM) capabilities, which can be used (with additional external electronics) for motorized speed control or autofocus control.

Period (in μs) and pulse width (in μs) are adjustable via the following registers (see also examples in Chapter [PWM: Examples in practice](#) on page 87):

Register	Name	Field	Bit	Description
0xF1000800	IO_OUTP_PWM1	Presence_Inq	[0]	Indicates presence of this feature (read only)
		---	[1]	Reserved
		---	[2..3]	Reserved
		MinPeriod	[4..19]	Minimum PWM period in μs (read only)
		---	[20..27]	Reserved
		---	[28..31]	Reserved
0xF1000804		PulseWidth	[0..15]	PWM pulse width in μs
		Period	[16..31]	PWM period in μs
0xF1000808	IO_OUTP_PWM2	Same as IO_OUTP_PWM1		
0xF100080C				
0xF1000810	IO_OUTP_PWM3	Same as IO_OUTP_PWM1		
0xF1000814				
0xF1000818	IO_OUTP_PWM4	Same as IO_OUTP_PWM1		
0xF100081C				

Table 31: PWM configuration registers

To enable the PWM feature select output mode 0x09. Control the signal state via the **PulseWidth** and **Period** fields (all times in microseconds (μs)).

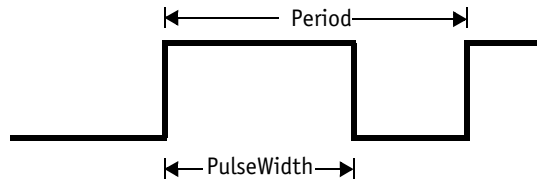

Figure 33: PulseWidth and Period definition

Note Note the following conditions:



- PulseWidth < Period
- Period ≥ MinPeriod

PWM: minimal and maximal periods and frequencies

In the following formulas you find the minimal/maximal periods and frequencies for the pulse-width modulation (PWM).

$$\begin{aligned} \text{period}_{\min} &= 3\mu\text{s} \\ \Rightarrow \text{frequency}_{\max} &= \frac{1}{\text{period}_{\min}} = \frac{1}{3\mu\text{s}} = 333.33\text{kHz} \\ \text{frequency}_{\min} &= \frac{1}{2^{16} \times 10^{-6}\text{s}} = 15.26\text{Hz} \\ \Rightarrow \text{period}_{\max} &= \frac{1}{\text{frequency}_{\min}} = 2^{16}\mu\text{s} \end{aligned}$$

Formula 1: Minimal/maximal period and frequency

PWM: Examples in practice

In this chapter we give you two examples, how to write values in the PWM registers. All values have to be written in microseconds (μs) in the PWM registers, therefore remember always the factor 10^{-6}s .

Example 1:

Set PWM with 1kHz at 30% pulse width.

$$\text{RegPeriod} = \frac{1}{\text{frequency} \times 10^{-6}\text{s}} = \frac{1}{1\text{kHz} \times 10^{-6}\text{s}} = 1000$$

$$\text{RegPulseWidth} = \text{RegPeriod} \times 30\% = 1000 \times 30\% = 300$$

Formula 2: PWM example 1

Example 2:

Set PWM with 250 Hz at 12% pulse width.

$$\text{RegPeriod} = \frac{1}{\text{frequency} \times 10^{-6}\text{s}} = \frac{1}{250\text{Hz} \times 10^{-6}\text{s}} = 4000$$

$$\text{RegPulseWidth} = \text{RegPeriod} \times 12\% = 4000 \times 12\% = 480$$

Formula 3: PWM example 2

Pixel data

Pixel data are transmitted as isochronous data packets in accordance with the 1394 interface described in IIDC V1.31. The first packet of a frame is identified by the **1** in the **sync bit** (sy) of the packet header.

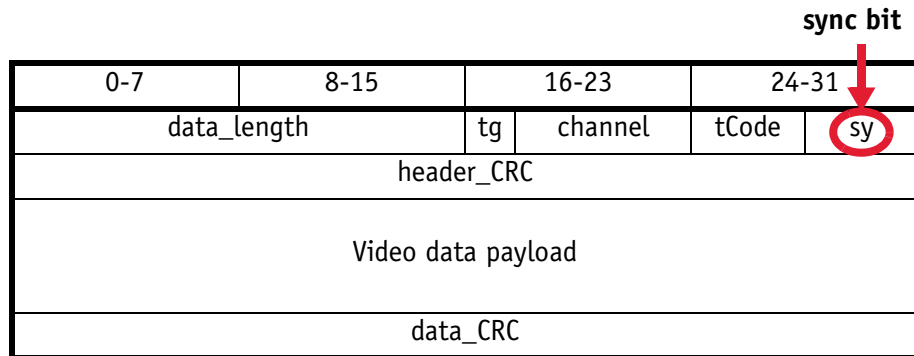

Table 32: Isochronous data block packet format. Source: IIDC V1.31

Field	Description
data_length	Number of bytes in the data field
tg	Tag field shall be set to zero
channel	Isochronous channel number , as programmed in the iso_channel field of the cam_sta_ctrl register
tCode	Transaction code shall be set to the isochronous data block packet tCode
sy	Synchronization value (sync bit) This is one single bit. It indicates the start of a new frame. It shall be set to 0001h on the first isochronous data block of a frame, and shall be set to zero on all other isochronous blocks
Video data payload	Shall contain the digital video information

Table 33: Description of data block packet format

- The video data for each pixel are output in either 8-bit or 14-bit format (**Packed 12-Bit Mode**: 12-bit format).
- Each pixel has a range of 256 or 16384 (**Packed 12-Bit Mode**: 4096) shades of grey.
- The digital value 0 is black and 255 or 16383 (**Packed 12-Bit Mode**: 4095) is white. In 16-bit mode the data output is MSB aligned.

Description of video data formats

The following tables provide a description of the video data format for the different modes. (Source: IIDC V1.31; packed 12-bit mode: AVT)

<YUV8 (4:2:2) format>

Each component has 8-bit data.

<YUV8 (4:2:2) format>			
$U_{(K+0)}$	$Y_{(K+0)}$	$V_{(K+0)}$	$Y_{(K+1)}$
$U_{(K+2)}$	$Y_{(K+2)}$	$V_{(K+2)}$	$Y_{(K+3)}$
$U_{(K+4)}$	$Y_{(K+4)}$	$V_{(K+4)}$	$Y_{(K+5)}$
$U_{(K+Pn-6)}$	$Y_{(K+Pn-6)}$	$V_{(K+Pn-6)}$	$Y_{(K+Pn-5)}$
$U_{(K+Pn-4)}$	$Y_{(K+Pn-4)}$	$V_{(K+Pn-4)}$	$Y_{(K+Pn-3)}$
$U_{(K+Pn-2)}$	$Y_{(K+Pn-2)}$	$V_{(K+Pn-2)}$	$Y_{(K+Pn-1)}$

Table 34: YUV8 (4:2:2) format: Source: IIDC V1.31

<YUV8 (4:1:1) format>

Each component has 8-bit data.

<YUV8 (4:1:1) format>			
$U_{(K+0)}$	$Y_{(K+0)}$	$Y_{(K+1)}$	$V_{(K+0)}$
$Y_{(K+2)}$	$Y_{(K+3)}$	$U_{(K+4)}$	$Y_{(K+4)}$
$Y_{(K+5)}$	$V_{(K+4)}$	$Y_{(K+6)}$	$Y_{(K+7)}$
$U_{(K+Pn-8)}$	$Y_{(K+Pn-8)}$	$Y_{(K+Pn-7)}$	$V_{(K+Pn-8)}$
$Y_{(K+Pn-6)}$	$Y_{(K+Pn-5)}$	$U_{(K+Pn-4)}$	$Y_{(K+Pn-4)}$
$Y_{(K+Pn-3)}$	$V_{(K+Pn-4)}$	$Y_{(K+Pn-2)}$	$Y_{(K+Pn-1)}$

Table 35: YUV8 (4:1:1) format: Source: IIDC V1.31

<Y (Mono8/Raw8) format>

Y component has 8-bit data.

<Y (Mono8/Raw8) format>			
$Y_{(K+0)}$	$Y_{(K+1)}$	$Y_{(K+2)}$	$Y_{(K+3)}$
$Y_{(K+4)}$	$Y_{(K+5)}$	$Y_{(K+6)}$	$Y_{(K+7)}$
$Y_{(K+Pn-8)}$	$Y_{(K+Pn-7)}$	$Y_{(K+Pn-6)}$	$Y_{(K+Pn-5)}$
$Y_{(K+Pn-4)}$	$Y_{(K+Pn-3)}$	$Y_{(K+Pn-2)}$	$Y_{(K+Pn-1)}$

Table 36: Y (Mono8) format: Source: IIDC V1.31 / Y (Raw8) format: AVT

<Y (Mono16/Raw16) format>

Y component has 16-bit data.

<Y (Mono16) format>	
High byte	Low byte
$Y_{(K+0)}$	$Y_{(K+1)}$
$Y_{(K+2)}$	$Y_{(K+3)}$
$Y_{(K+Pn-4)}$	$Y_{(K+Pn-3)}$
$Y_{(K+Pn-2)}$	$Y_{(K+Pn-1)}$

Table 37: Y (Mono16) format: Source: IIDC V1.31

<Y (Mono12/Raw12) format>

<Y (Mono12) format>			
$Y_{(K+0)}$ [11..4]	$Y_{(K+1)}$ [3..0] $Y_{(K+0)}$ [3..0]	$Y_{(K+1)}$ [11..4]	$Y_{(K+2)}$ [11..4]
$Y_{(K+3)}$ [3..0] $Y_{(K+2)}$ [3..0]	$Y_{(K+3)}$ [11..4]	$Y_{(K+4)}$ [11..4]	$Y_{(K+5)}$ [3..0] $Y_{(K+4)}$ [3..0]
$Y_{(K+5)}$ [11..4]	$Y_{(K+6)}$ [11..4]	$Y_{(K+7)}$ [3..0] $Y_{(K+6)}$ [3..0]	$Y_{(K+7)}$ [11..4]

Table 38: **Packed 12-Bit Mode** (mono and raw) Y12 format (AVT)

<Y(Mono8/Raw8), RGB8>

Each component (Y, R, G, B) has 8-bit data. The data type is *Unsigned Char*.

Y, R, G, B	Signal level (decimal)	Data (hexadecimal)
Highest	255	0xFF
	254	0xFE
	.	.
	.	.
Lowest	1	0x01
	0	0x00

Figure 34: Data structure of Mono8, RGB8; Source: IIDC V1.31 / Y(Mono8/Raw8) format: AVT

<YUV8>

Each component (Y, U, V) has 8-bit data. The Y component is the same as in the above table.

U, V	Signal level (decimal)	Data (hexadecimal)
Highest (+)	127	0xFF
	126	0xFE
	.	.
	.	.
Lowest	1	0x81
	0	0x80
	-1	0x7F
Highest (-)	-127	0x01
	-128	0x00

Figure 35: Data structure of YUV8; Source: IIDC V1.31

<Y(Mono16)>

Y component has 16-bit data. The data type is *Unsigned Short (big-endian)*.

Y	Signal level (decimal)	Data (hexadecimal)
Highest	65535	0xFFFF
	65534	0xFFFE
	.	.
	.	.
Lowest	1	0x0001
	0	0x0000

Figure 36: Data structure of Y(Mono16); Source: IIDC V1.31

<Y(Mono12)>

Y component has 12-bit data. The data type is *unsigned*.

Y	Signal level (decimal)	Data (hexadecimal)
Highest	4095	0x0FFF
	4094	0x0FFE
	.	.
	.	.
	1	0x0001
Lowest	0	0x0000

Table 39: Data structure of **Packed 12-Bit Mode** (mono and raw) (AVT)

Description of the data path

Block diagrams of the cameras

The following diagrams illustrate the data flow and the bit resolution of image data after being read from the CCD sensor chip in the camera. The individual blocks are described in more detail in the following paragraphs. For sensor data see Chapter [Specifications](#) on page 38.

Black and white cameras

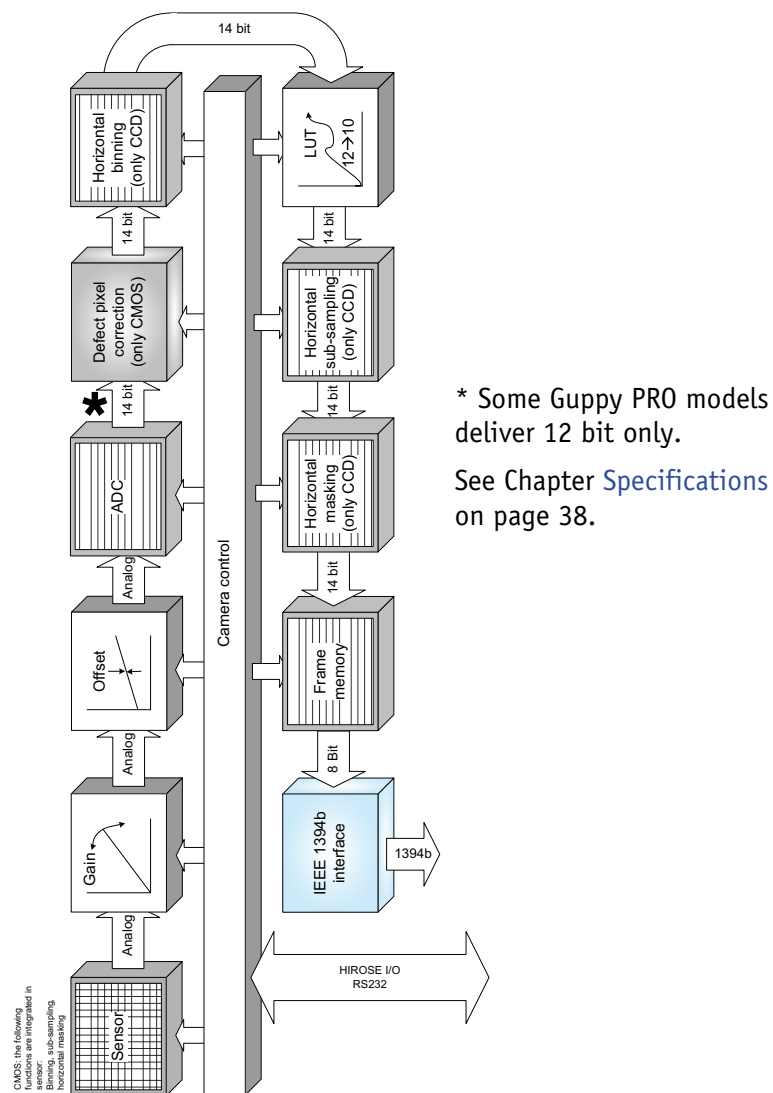
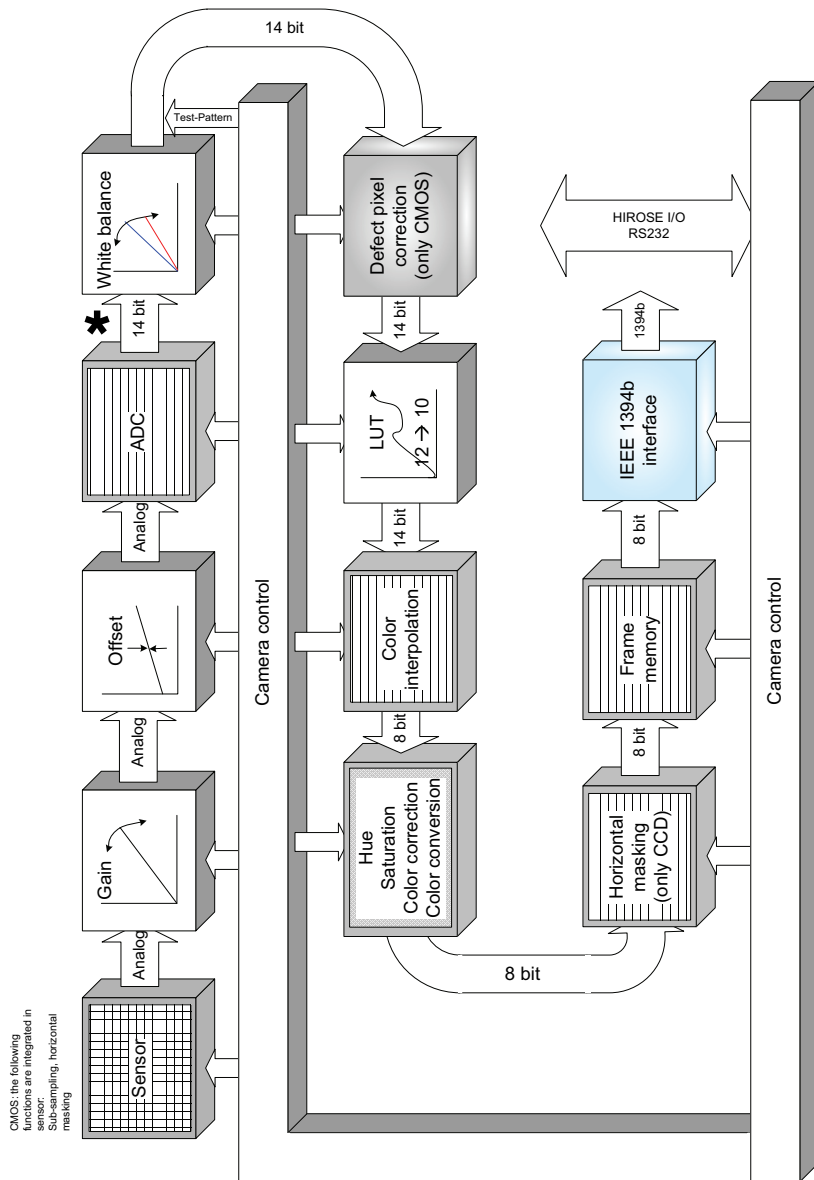

Figure 37: Block diagram b/w camera

Setting LUT = OFF effectively makes full use of the 14 bit by bypassing the LUT circuitry; setting LUT = ON means that the most significant 12 bit of the 14 bit are used and further down converted to 10 bit. For cameras with 12-bit ADC: the most significant 10 bit of the 12 bit are used.

Color cameras



* Some Guppy PRO models deliver 12 bit only.
See Chapter [Specifications](#) on page 38.

Figure 38: Block diagram color camera

Setting LUT = OFF effectively makes full use of the 14 bit by bypassing the LUT circuitry; setting LUT = ON means that the most significant 12 bit of the 14 bit are used and further down converted to 10 bit. For cameras with 12-bit ADC: the most significant 10 bit of the 12 bit are used.

White balance

There are two types of white balance:

- **one-push white balance:** white balance is done only once (not continuously)
- **auto white balance (AWB):** continuously optimizes the color characteristics of the image

Guppy PRO color cameras have both **one-push white balance** and **auto white balance**.

White balance is applied so that non-colored image parts are displayed non-colored.

From the user's point, the white balance settings are made in register 80Ch of IIDC V1.31. This register is described in more detail below.

Register	Name	Field	Bit	Description
0xF0F0080C	WHITE_BALANCE	Presence_Inq	[0]	Presence of this feature: 0: N/A 1: Available
		Abs_Control	[1]	Absolute value control 0: Control with value in the Value field 1: Control with value in the Absolute value CSR If this bit=1, the value in the Value field will be ignored.
		---	[2..4]	Reserved
		One_Push	[5]	Write 1: begin to work (self-cleared after operation) Read: 1: in operation 0: not in operation If A_M_Mode = 1, this bit will be ignored.
		ON_OFF	[6]	Write: ON or OFF this feature Read: read a status 0: OFF 1: ON
		A_M_MODE	[7]	Write: set mode Read: read current mode 0: MANUAL 1: AUTO
		U/B_Value	[8..19]	U/B value This field is ignored when writing the value in Auto or OFF mode. If readout capability is not available, reading this field has no meaning.
		V/R_Value	[20..31]	V/R value This field is ignored when writing the value in Auto or OFF mode. If readout capability is not available, reading this field has no meaning.

Table 40: White balance register

The values in the **U/B_Value** field produce changes from green to blue; the **V/R_Value** field from green to red as illustrated below.

Note While lowering both U/B and V/R registers from 284 towards 0, the lower one of the two effectively controls the green gain.

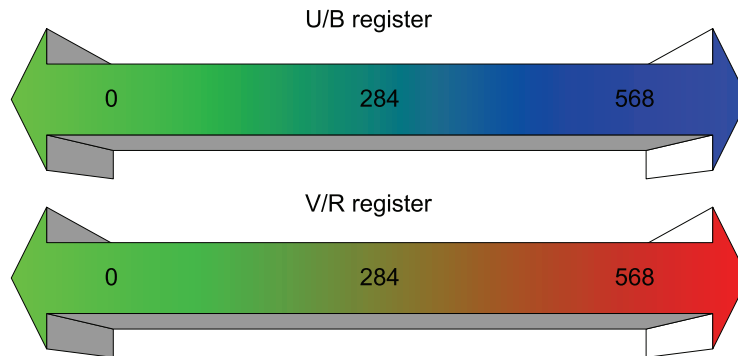

Figure 39: U/V slider range

Type	Range	Range in dB
Guppy PRO color cameras	0 ... 568	± 10 dB

Table 41: U/V slider range of the various Guppy PRO types

The increment length is ~0.0353 dB/step.

One-push white balance

Note **Configuration**



To configure this feature in control and status register (CSR): See [Table 40: White balance register](#) on page 97.

The camera automatically generates frames, based on the current settings of all registers (GAIN, OFFSET, SHUTTER, etc.).

For white balance, in total **9** frames are processed. For the white balance algorithm the whole image or a subset of it is used. The R-G-B component values of the samples are added and are used as actual values for the **one-push white balance**.

This feature uses the assumption that the R-G-B component sums of the samples shall be equal; i.e., it assumes that the average of the sampled grid pixels is to be monochrome.

Note The following ancillary conditions should be observed for successful white balance:



- There are no stringent or special requirements on the image content, it requires only the presence of monochrome pixels in the image.

If the image capture is active (e.g. **IsoEnable** set in register 614h), the frames used by the camera for white balance are also output on the 1394 bus. Any previously active image capture is restarted after the completion of white balance.

The following flow diagram illustrates the **one-push white balance** sequence.

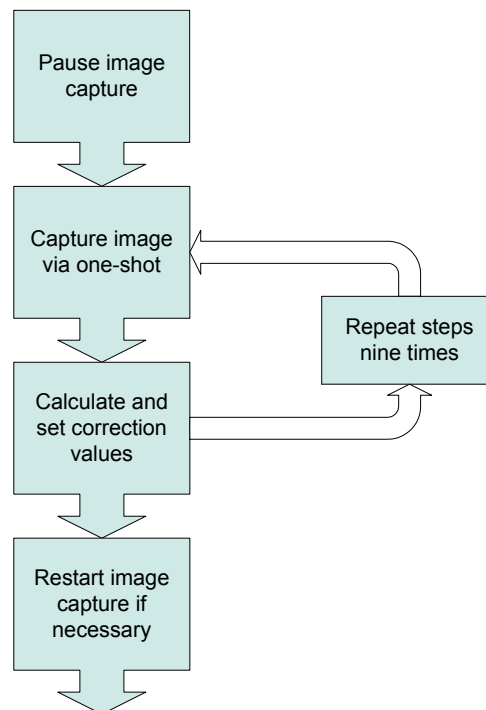

Figure 40: **One-push white balance** sequence

Finally, the calculated correction values can be read from the `WHITE_BALANCE` register 80Ch.

Auto white balance (AWB)

The **auto white balance** feature continuously optimizes the color characteristics of the image.

For the white balance algorithm the whole image or a subset of it is used.

Auto white balance can also be enabled by using an external trigger. However, if there is a pause of >10 seconds between capturing individual frames this process is aborted.

Note The following ancillary conditions should be observed for successful white balance:



- There are no stringent or special requirements on the image content, it requires only the presence of equally weighted RGB pixels in the image.
- **Auto white balance** can be started both during active image capture and when the camera is in idle state.

Note **Configuration**



To set position and size of the control area (Auto_Function_AOI) in an advanced register: see [Table 136: Advanced register: Autofunction AOI](#) on page 256.

AUTOFNC_AOI affects the auto shutter, auto gain and auto white balance features and is independent of the Format_7 AOI settings. If this feature is switched off the work area position and size will follow the current active image size.

Within this area, the R-G-B component values of the samples are added and used as actual values for the feedback.

The following drawing illustrates the AUTOFNC_AOI settings in greater detail.

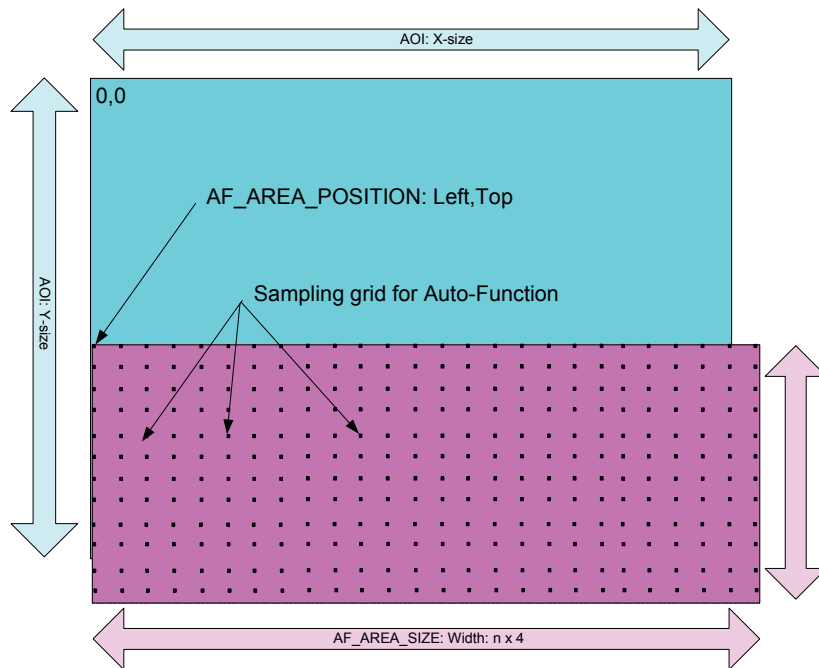

Figure 41: AUTOFNC_AOI positioning

The algorithm is based on the assumption that the R-G-B component sums of the samples are equal, i.e., it assumes that the mean of the sampled grid pixels is to be monochrome.

Auto shutter

In combination with auto white balance, Guppy PRO cameras are equipped with **auto shutter** feature.

When enabled, the auto shutter adjusts the shutter within the default shutter limits or within those set in advanced register F1000360h in order to reach the reference brightness set in auto exposure register.

Note **Target grey level** parameter in **SmartView** corresponds to **Auto_exposure** register 0xF0F00804 (IIDC).



Increasing the auto exposure value increases the average brightness in the image and vice versa.

The applied algorithm uses a proportional plus integral controller (PI controller) to achieve minimum delay with zero overshoot.

To configure this feature in control and status register (CSR):

Register	Name	Field	Bit	Description
0xF0F0081C	SHUTTER	Presence_Inq	[0]	Presence of this feature: 0: N/A 1: Available
		Abs_Control	[1]	Absolute value control 0: Control with value in the Value field 1: Control with value in the Absolute value CSR If this bit=1, the value in the Value field will be ignored.
		---	[2..4]	Reserved
		One_Push	[5]	Write 1: begin to work (self-cleared after operation) Read: 1: in operation 0: not in operation If A_M_Mode = 1, this bit will be ignored.
		ON_OFF	[6]	Write: ON or OFF this feature Read: read a status 0: OFF 1: ON
		A_M_MODE	[7]	Write: set mode Read: read current mode 0: MANUAL 1: AUTO
		---	[8..19]	Reserved
		Value	[20..31]	Read/Write Value This field is ignored when writing the value in Auto or OFF mode. If readout capability is not available, reading this field has no meaning.

Table 42: CSR: **Shutter**

Note



Configuration

To configure this feature in an advanced register: See [Table 134: Advanced register: Auto shutter control](#) on page 254.

Auto gain

All Guppy PRO cameras are equipped with **auto gain** feature.

Note Configuration



To configure this feature in an advanced register: See [Table 135: Advanced register: Auto gain control](#) on page 255.

When enabled auto gain adjusts the gain within the default gain limits or within the limits set in advanced register F1000370h in order to reach the brightness set in auto exposure register as reference.

Increasing the auto exposure value (aka **target grey value**) increases the average brightness in the image and vice versa.

The applied algorithm uses a proportional plus integral controller (PI controller) to achieve minimum delay with zero overshoot.

The following tables show the gain and auto exposure CSR.

Register	Name	Field	Bit	Description
0xF0F00820	GAIN	Presence_Inq	[0]	Presence of this feature: 0: N/A 1: Available
		Abs_Control	[1]	Absolute value control 0: Control with value in the value field 1: Control with value in the absolute value CSR If this bit=1 the value in the value field has to be ignored.
		---	[2..4]	Reserved
		One_Push	[5]	Write: Set bit high to start Read: Status of the feature: Bit high: WIP Bit low: Ready
		ON_OFF	[6]	Write: ON or OFF this feature Read: read a status 0: OFF 1: ON
		A_M_MODE	[7]	Write: set mode Read: read current mode 0: MANUAL 1: AUTO
		---	[8..19]	Reserved
		Value	[20..31]	Read/Write Value This field is ignored when writing the value in Auto or OFF mode. If readout capability is not available, reading this field has no meaning.

Table 43: CSR: Gain

Register	Name	Field	Bit	Description
0xF0F00804	AUTO_EXPOSURE	Presence_Inq	[0]	Presence of this feature: 0: N/A 1: Available
		Abs_Control	[1]	Absolute value control 0: Control with value in the value field 1: Control with value in the absolute value CSR If this bit=1 the value in the value field has to be ignored.
		---	[2..4]	Reserved
		One_Push	[5]	Write: Set bit high to star Read: Status of the feature: Bit high: WIP Bit low: Ready
		ON_OFF	[6]	Write: ON or OFF this feature Read: read a status 0: OFF 1: ON
		A_M_MODE	[7]	Write: set mode Read: read current mode 0: MANUAL 1: AUTO
		---	[8..19]	Reserved
		Value	[20..31]	Read/Write Value This field is ignored when writing the value in Auto or OFF mode. If readout capability is not available, reading this field has no meaning.

Table 44: CSR: Auto Exposure

Note**Configuration**

To configure this feature in an advanced register: See [Table 135: Advanced register: Auto gain control](#) on page 255.

Note



- Values can only be changed within the limits of gain CSR.
- Changes in auto exposure register only have an effect when auto gain is active.
- Auto exposure limits are 50..205. (**SmartView**→**Ctrl1 tab: Target grey level**)

Manual gain

Guppy PRO cameras are equipped with a gain setting, allowing the gain to be **manually** adjusted on the fly by means of a simple command register write. The following ranges can be used when manually setting the gain for the analog video signal:

Type	Range	Range in dB	Increment length
Guppy PRO CCD cameras	0 ... 680	0 ... 24.4 dB	~0.0359 dB/step
Guppy PRO F-503 (CMOS camera)	8 ... 32	0 ... 12.04 dB	~0.125/step (1.02 - 0.28 dB/step)
	33 ... 48	12.57 ... 18.06 dB	~0.5/step (0.53 - 0.28 dB/step)

Table 45: Manual gain range of the various Guppy PRO types

Note



- Setting the gain does not change the offset (black value)
- A higher gain produces greater image noise. This reduces image quality. For this reason, try first to increase the brightness, using the aperture of the camera optics and/or longer shutter settings.

Brightness (black level or offset)

It is possible to set the black level in the camera within the following ranges:
 0 ... +16 grey values (@ 8 bit)
 Increments are in 1/64 LSB (@ 8 bit)

Note



- Setting the gain does not change the offset (black value).

The IIDC register brightness at offset 800h is used for this purpose.

The following table shows the BRIGHTNESS register:

Register	Name	Field	Bit	Description
0xF0F00800	BRIGHTNESS	Presence_Inq	[0]	Presence of this feature: 0: N/A 1: Available
		Abs_Control	[1]	Absolute value control 0: Control with value in the value field 1: Control with value in the absolute value CSR If this bit= 1 the value in the value field has to be ignored
		---	[2..4]	Reserved
		One_Push	[5]	Write: Set bit high to start Read: Status of the feature: Bit high: WIP Bit low: Ready
		ON_OFF	[6]	Write: ON or OFF this feature Read: read a status 0: OFF 1: ON
		A_M_MODE	[7]	Write: set mode Read: read current mode 0: MANUAL 1: AUTO
		---	[8..19]	Reserved
		Value	[20..31]	Read/Write Value; this field is ignored when writing the value in Auto or OFF mode; if readout capability is not available reading this field has no meaning.

Table 46: CSR: **Brightness**

Mirror function (only Guppy PRO F-503)

Guppy PRO F-503 cameras are equipped with a mirror function, which is built directly into the sensor. The mirror is centered to the current FOV center and can be combined with all image manipulation functions, like **binning**.

This function is especially useful when the camera is looking at objects with the help of a mirror or in certain microscopy applications.

- With Guppy PRO F-503B, **horizontal and vertical mirror** is possible.
- With Guppy PRO F-503C, only **horizontal mirror** is possible.

Note



Configuration

To configure this feature in an advanced register: See [Table 139: Advanced register: Mirror](#) on page 258.

Note



The use of the mirror function with color cameras and image output in RAW format has implications on the BAYER-ordering of the colors.

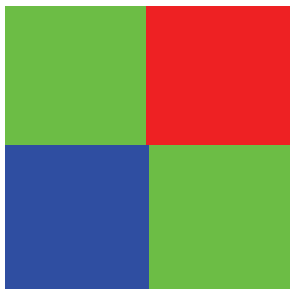

Mirror OFF: G-R-B-G (only F-503C)



Horizontal mirror ON: R-G-G-B (only F- 503C)

Figure 42: Mirror and Bayer order

Note



During switchover one image may be temporarily corrupted.

Look-up table (LUT) and gamma function

The AVT Guppy PRO camera provides **one** user-defined look-up table (LUT). The use of this LUT allows any function (in the form $\text{Output} = F(\text{Input})$) to be stored in the camera's RAM and to be applied on the individual pixels of an image at run-time.

The address lines of the RAM are connected to the incoming digital data, these in turn point to the values of functions which are calculated offline, e.g. with a spreadsheet program.

This function needs to be loaded into the camera's RAM before use.

One example of using an LUT is the gamma LUT:

There is one gamma LUT (gamma= 0.45)

$$\text{Output} = (\text{Input})^{0.45}$$

or with normalized values:

$$\text{Output}/1023 = (\text{Input}/4095)^{0.45}$$

This gamma LUT is used with all Guppy PRO models.

Gamma is known as compensation for the nonlinear brightness response of many displays e.g. CRT monitors. The look-up table converts the incoming **12 bit** from the digitizer to outgoing **10 bit**.

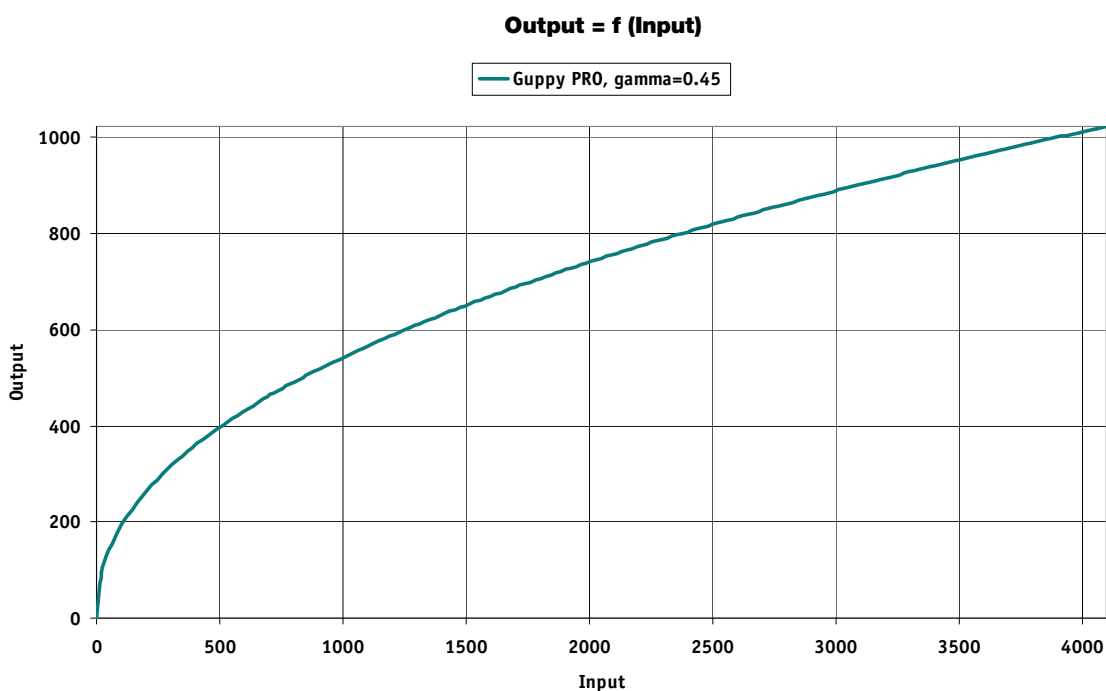

Figure 43: LUT with gamma= 0.45

Note



- The input value is the most significant **12-bit** value from the digitizer.
- Gamma 1 (gamma= 0.45) switches on the LUT. After overriding the LUT with a user defined content, gamma functionality is no longer available until the next full initialization of the camera.
- LUT content is volatile if you do not use the user profiles to save the LUT.

Loading an LUT into the camera

Loading the LUT is carried out through the data exchange buffer called Gpdata_BUFFER. As this buffer can hold a maximum of 2 kB, and a complete LUT at 4096 x 10 bit is 5 kByte, programming can not take place in a one block write step because the size of an LUT is larger than Gpdata_BUFFER. Therefore input must be handled in several steps. The flow diagram below shows the sequence required to load data into the camera.

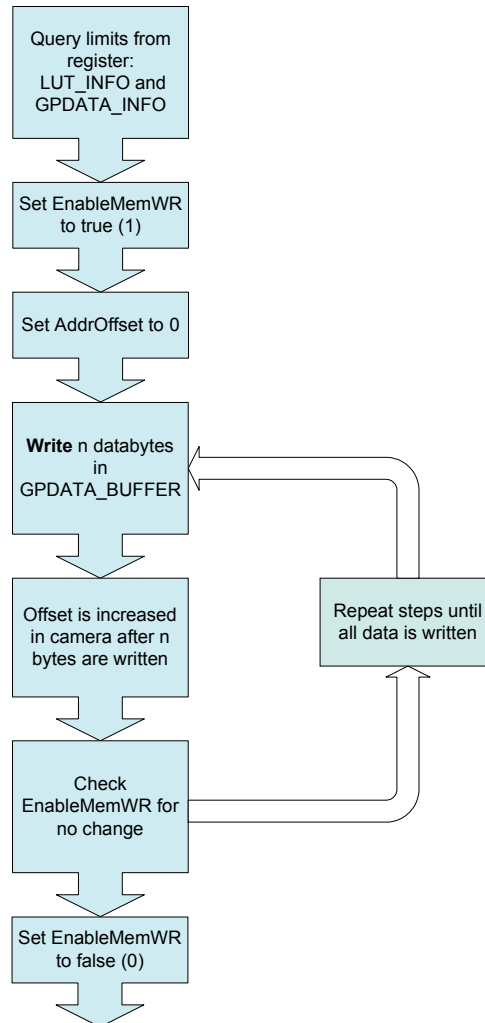

Figure 44: Loading an LUT

Note



Configuration

- To configure this feature in an advanced register: See [Table 131: Advanced register: LUT on page 248](#).
- For information on Gpdata_BUFFER: See Chapter [Gpdata_BUFFER on page 269](#).

Defect pixel correction (only Guppy PRO F-503B/C)

The mechanisms of defect pixel correction are explained in the following drawings. All examples are done in Format_7 Mode_0 (full resolution).

The first two examples are explained for b/w cameras, the third and fourth example are explained for color cameras.

The **X** marks a defect pixel.

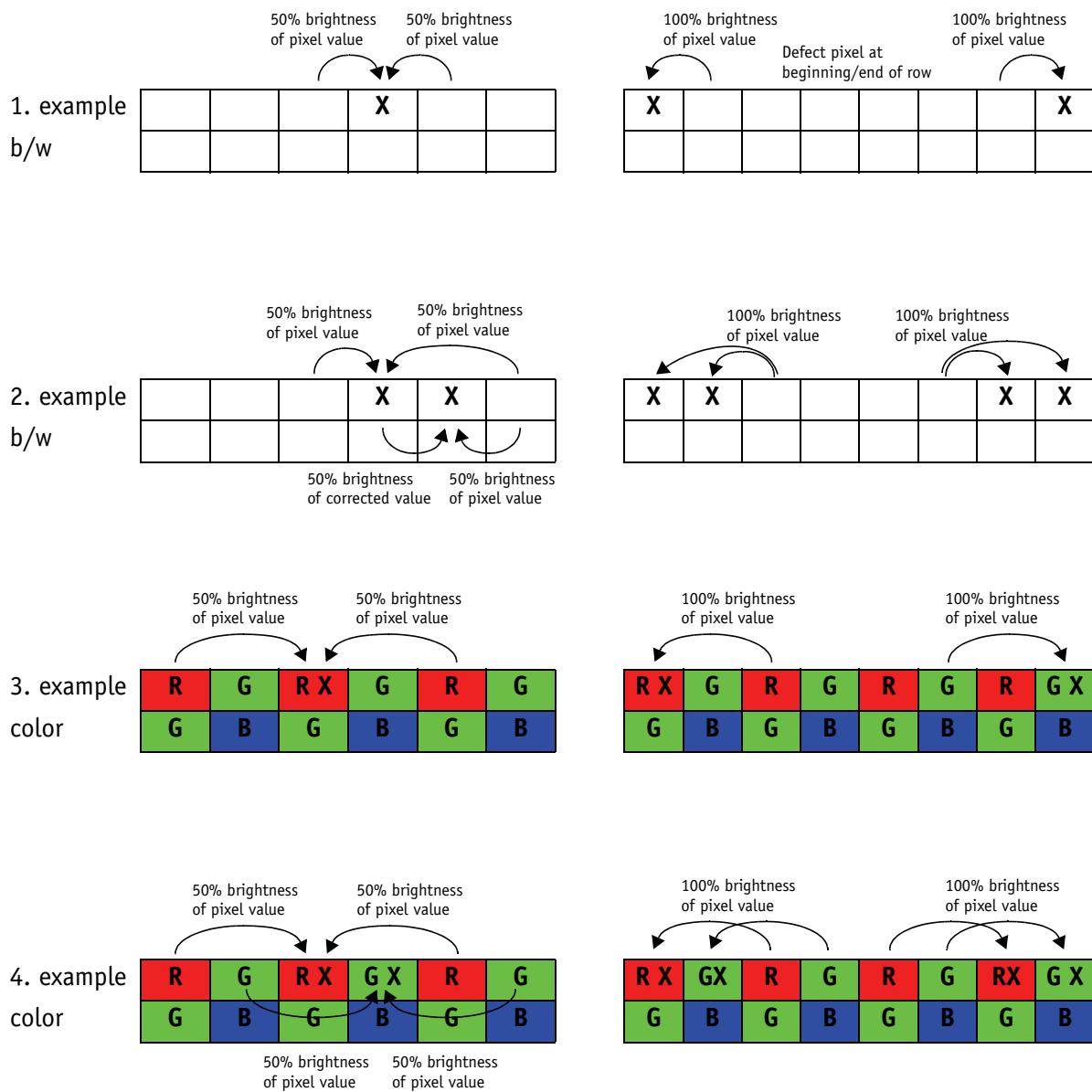

Figure 45: Mechanisms of defect pixel correction

Note



While building defect pixel correction data or uploading them from host, the defect pixel correction data are stored **volatile** in FPGA.

Optionally you can store the data in a **non-volatile** memory (Set MemSave to 1).

Note



Configuration

To configure this feature in an advanced register: See [Table 132: Advanced register: Defect pixel correction](#) on page 250.

Building defect pixel data

Note



- Defect pixel correction is **only possible in Mono8 modes for monochrome cameras and Raw8 modes for color cameras.**
- In all other modes you get an error message in advanced register 0xF1000298 bit [1] see [Table 132: Advanced register: Defect pixel correction](#) on page 250.
- Using Format_7 Mode_x: Defect pixel correction is done in **Format_7 Mode_x.**
- Using a fixed format (Format_0, Format_1 or Format_2): Defect pixel correction is done in **Format_7 Mode_0.**
- When using defect pixel correction with **binning and sub-sampling**: first switch to binning/sub-sampling mode and then apply defect pixel correction.

The following flow diagram illustrates the defect pixel correction:

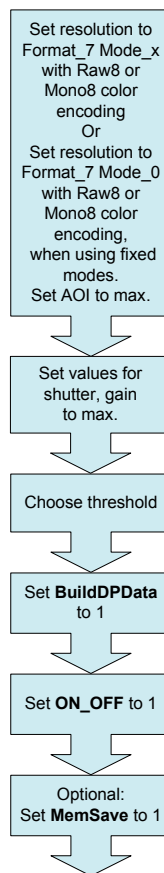

Figure 46: Defect pixel correction: build and store

To build defect pixel data perform the following steps:

Grab an image with defect pixel data

1. Take the camera, remove lens and put on lens cap.
2. Set image resolution to Format_7 Mode_x or Format_7 Mode_0 (when using fixed modes) with Raw8 or Mono8 color encoding, and set AOI to maximum.
3. Set values for shutter and gain to maximum.
4. Grab a single image (one-shot).

Calculate defect pixel coordinates

5. Accept default threshold from system or choose own threshold.

Note

A mean value is calculated over the entire image that was grabbed previously.



Definition: A defect pixel is every pixel value of this previously grabbed image that is:

- greater than (mean value + threshold)
- or
- less than (mean value - threshold)

6. Set the **BuildDPData** flag to 1.

In microcontroller the defect pixel calculation is started. The detected defect pixel coordinates are stored.

Defect pixel coordinates are:

- 16-bit y-coordinate and
- 16-bit x-coordinate

DPC data are organized like this:

31	16	15	0
y-coordinate		x-coordinate	

The calculated mean value is written in advanced register **Mean** field (0xF1000298 bit [18..24]).

The number of defect pixels is written in advanced register **DPDataSize** (0xF100029C bit [4..17]). Due to 16-bit format: to get the number of defect pixels read out this value and divide through 4. For more information see [Table 132: Advanced register: Defect pixel correction](#) on page 250f.

Reset values (resolution, shutter, gain, brightness)

7. Take the camera, remove lens cap and thread the lens onto the camera.
8. Reset values for image resolution, shutter, gain and brightness (offset) to their previous values.

9. Grab a single image (one-shot).

Activate/deactivate defect pixel correction

Activate:

1. Set **ON_OFF** flag to **1**.

Deactivate:

1. Set **ON_OFF** flag to **0**.

Store defect pixel data non-volatile

1. Set the **MemSave** flag to **1**.

Load non-volatile stored defect pixel data

1. Set the **MemLoad** flag to **1**.

All non-volatile stored defect pixel coordinates are loaded.

Note



- Switch off camera and switch on again:
⇒ defect pixel data will get lost
- Initialize camera (start-up or soft reset):
⇒ non-volatile stored defect pixel data are loaded automatically

Send defect pixel data to the host

1. Set **EnaMemRD** flag to **1**.

Defect pixel data is transferred from dual port RAM to host.

2. Read **DPDataSize**.

This is the current defect pixel count from the camera.

Receive defect pixel data from the host

1. Set **EnaMemWR** flag to **1**.

Binning (only b/w cameras; F-503: also color cameras)

2 x binning (F-503 also 4 x)

Definition **Binning** is the process of combining neighboring pixels while being read out from the sensor.

Note

- Binning does not change offset, brightness or black-level.



Binning is used primarily for 3 reasons:

- a reduction in the number of pixels and thus the amount of data while retaining the original image area angle
- an increase in the frame rate (CCD models: vertical binning only; CMOS models: also horizontal binning)
- a brighter image, also resulting in an improvement in the signal-to-noise ratio of the image

Signal-to-noise ratio (SNR) and **signal-to-noise separation** specify the quality of a signal with regard to its reproduction of intensities. The value signifies how high the ratio of noise is in regard to the maximum achievable signal intensity.

The higher this value, the better the signal quality. The unit of measurement used is generally known as the decibel (dB), a logarithmic power level. 6 dB is the signal level at approximately a factor of 2.

However, the advantages of increasing signal quality are accompanied by a reduction in resolution.

Only Format_7 **Binning** is possible only in video Format_7. The type of binning used depends on the video mode.

Types In general, we distinguish between the following types of binning (H=horizontal, V=vertical):

- 2 x H-binning
- 2 x V-binning
- 4 x H-binning (only F-503)
- 4 x V-binning (only F-503)

and the full binning modes:

- 2 x full binning (a combination of 2 x H-binning and 2 x V-binning)
- 4 x full binning (a combination of 4 x H-binning and 4 x V-binning) (only F-503)

For Guppy F-503 there are also mixed modes via mode mapping available:

For example:

- 4 x H-binning 2 x V-binning (only F-503)
- 2 x H-binning 4 x V-binning (only F-503)

... and many other mixed modes. For more information see the mapping table of possible Format_7 modes (for F-503 only) on page 132.

Vertical binning

Light sensitivity **Vertical binning** increases the light sensitivity of the camera by a factor of two (monochrome CCD models). Guppy PRO F-503B/C have only averaged binning (low-noise binning) without any increase in light sensitivity.

In the **CCD** sensors, this is done directly in the horizontal shift register of the monochrome sensor.

With the **CMOS** sensor of Guppy PRO F-503B/C, monochrome and color binning is possible. The monochrome CMOS sensor of Guppy PRO F-503B uses the same binning patterns as the color version.

Format_7 Mode_2 By default and without further remapping use **Format_7 Mode_2** for 2 x vertical binning.

This reduces vertical resolution, depending on the model.

Binning mode	CCD models (monochrome)	Guppy PRO F-503B/C
2 x vertical binning	2 pixel signals from 2 vertical neighboring pixels are combined and their signals are added .	2 pixel signals from 2 vertical adjacent same-color pixels are combined and their signals are always averaged (low-noise binning)
4 x vertical binning	not applicable	4 pixel signals from 4 vertical adjacent same-color pixels are combined and their signals are always averaged (low-noise binning)
Averaged? or Added?	Added	Averaged (low-noise binning)
When the signals are averaged , the image will not be brighter than without binning. When the signals are added , the image will be brighter than without binning.		

Table 47: Definition of 2 x and 4 x vertical binning

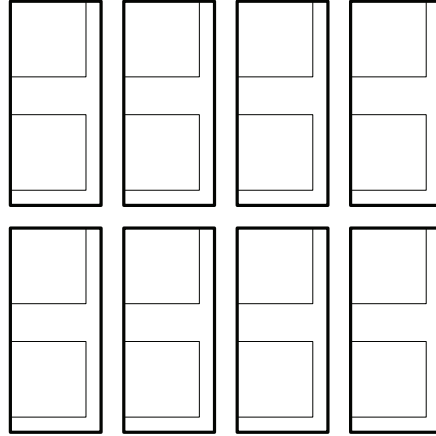

Figure 47: 2 x vertical binning (CCD models)

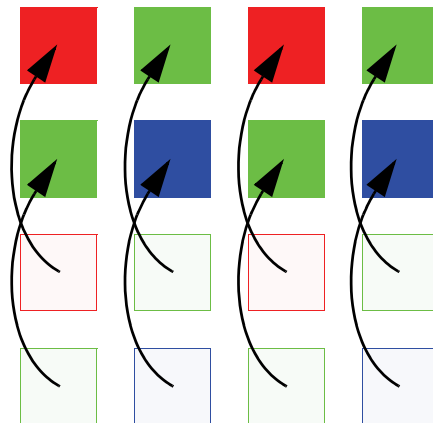

Figure 48: 2 x vertical binning (**Guppy PRO F-503B/C**)

Note

Vertical resolution is reduced, but **signal-to noise ratio (SNR)** is increased by about 3 or 6 dB (2 x or 4 x binning).



Note



The image appears **vertically** compressed in this mode and no longer exhibits a true aspect ratio.

If **vertical binning** is activated the image may appear to be over-exposed and may require correction.

Horizontal binning

Definition	(CCD cameras only) In horizontal binning adjacent pixels of a row are combined digitally in the FPGA of the camera without accumulating the black level. CMOS cameras: horizontal binning is done in the CMOS sensor. With the CMOS sensor of Guppy PRO F-503C, color binning is possible. The monochrome CMOS sensor of Guppy PRO F-503B uses the same binning patterns as the color version. Using Guppy PRO F-503B/C you can choose between averaging and additive binning.
Light sensitivity	This means that in horizontal binning the light sensitivity of the camera is also increased by a factor of two (6 dB) or 4 (12 dB). This is only true for added binning but not for averaged binning (low-noise binning). Signal-to-noise separation improves by approx. 3 or 6 dB.
Horizontal resolution	Horizontal resolution is lowered, depending on the model.
Format_7 Mode_1	By default and without further remapping use Format_7 Mode_1 for 2 x horizontal binning.
Low-noise binning	For Guppy PRO F-503, low-noise binning (averaged pixel signals) is available. To activate this mode see Chapter Low-noise binning mode (2 x and 4 x binning) (only Guppy PRO F-503) on page 263.

Binning mode	CCD models (monochrome)	Guppy PRO F-503B/C
2 x horizontal binning	2 pixel signals from 2 horizontal neighboring pixels are combined and their signals are added .	2 pixel signals from 2 horizontal adjacent same-color pixels are combined and their signals are added or averaged (low-noise binning) . Default: Added
4 x horizontal binning	not applicable	4 pixel signals from 4 horizontal adjacent same-color pixels are combined and their signals are added or averaged (low-noise binning) . Default: Added.
Averaged? or Added?	Only added	Added or averaged. Default: added
<p>When the signals are averaged, the image will not be brighter than without binning.</p> <p>When the signals are added, the image will be brighter than without binning.</p>		

Table 48: Definition of 2 x and 4 x horizontal binning

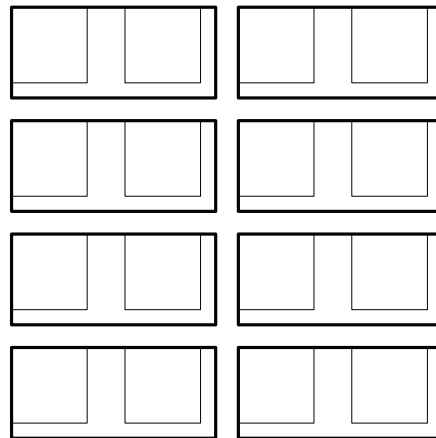

Figure 49: 2 x horizontal binning (CCD models)

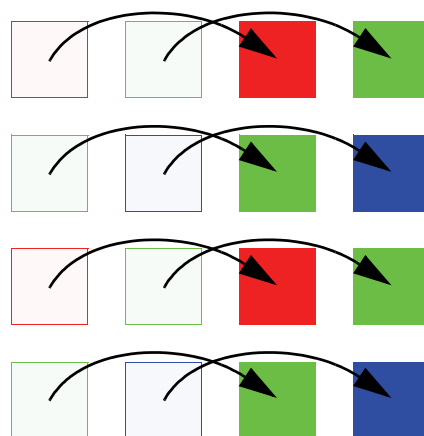

Figure 50: 2 x horizontal binning (**Guppy PRO F-503B/C**)

Note



The image appears **horizontally** compressed in this mode and does no longer show true aspect ratio.

If **horizontal binning** is activated the image may appear to be over-exposed and must be corrected, if necessary.

2 x full binning (F-503 also 4 x full binning)

If horizontal and vertical binning are combined, every 4 (16) pixels are consolidated into a single pixel. At first two (4) vertical pixels are put together and then combined horizontally. With the CMOS sensor of Guppy PRO F-503C, color binning is possible. The monochrome CMOS sensor of Guppy PRO F-503B uses the same binning patterns as the color version.

Light sensitivity	This increases light sensitivity by a total of a factor of 4 (16) and at the same time signal-to-noise separation is improved by about 6 (12) dB (not low-noise binning).
Resolution	Resolution is reduced, depending on the model.
Format_7 Mode_3	By default and without further remapping use Format_7 Mode_3 for 2 x full binning.
Low-noise binning	For Guppy PRO F-503, low-noise binning (averaged pixel signals) is available. To activate this mode see Chapter Low-noise binning mode (2 x and 4 x binning) (only Guppy PRO F-503) on page 263

Binning mode	CCD models (monochrome)	Guppy PRO F-503B/C
2 x full binning	4 pixel signals from 2 neighboring rows and columns are combined and their signals are added .	4 pixel signals from 2 adjacent rows and columns (same-color pixels) are combined and their signals are horizontally added/averaged and vertically averaged .
4 x full binning	not applicable	16 pixel signals from 4 adjacent rows and columns (same-color pixels) are combined and their signals are horizontally added/averaged and vertically averaged .
Averaged? or Added?	Added	Horizontal: added or averaged Vertical: averaged
<p>When the signal is averaged, the image will not be brighter than without binning. When the signal is added, the image will be brighter than without binning.</p>		

Table 49: Definition of 2 x and 4 x full binning

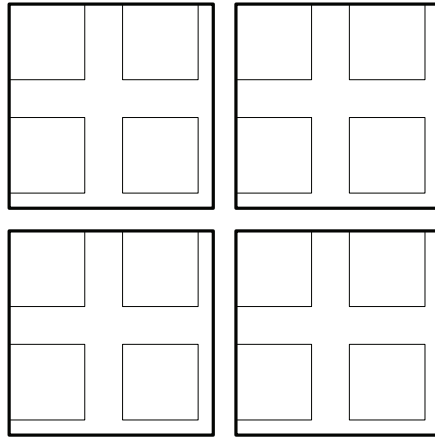

Figure 51: Full binning (CCD models)

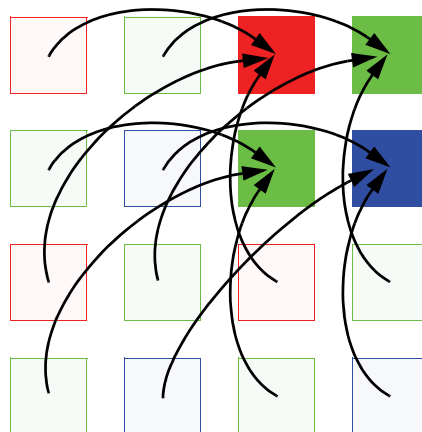

Figure 52: 2 x full binning (**Guppy PRO F-503**)

Note

If **full binning** is activated the image may appear to be over-exposed and must be corrected, if necessary.



Sub-sampling (only F-503B/C and CCD cameras b/w)

What is sub-sampling?

Definition Sub-sampling is the process of skipping neighboring pixels (with the same color) while being read out from the CCD chip.

Which Guppy PRO models have sub-sampling?

- **CMOS Guppy PRO** cameras (F-503B/C) (b/w and color cameras) have sub-sampling.
- **CCD Guppy PRO** cameras: only b/w cameras have sub-sampling (only 2x horizontal/vertical/H+V)

Description of sub-sampling

Sub-sampling is used primarily for the following reason:

- A reduction in the number of pixels and thus the amount of data while retaining the original image area angle and image brightness

Similar to binning mode the cameras support horizontal, vertical and h+v sub-sampling mode.

Format_7 Mode_4 By default and without further remapping use **Format_7 Mode_4** for

- Guppy PRO F-503B: 2 out of 4 horizontal sub-sampling
- Guppy PRO F-503C: 2 out of 4 horizontal sub-sampling

The different sub-sampling patterns are shown below.

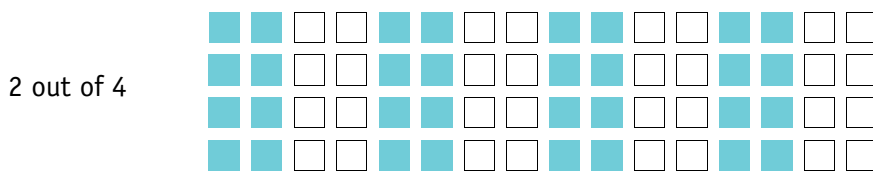

Figure 53: Horizontal sub-sampling 2 out of 4 (b/w)

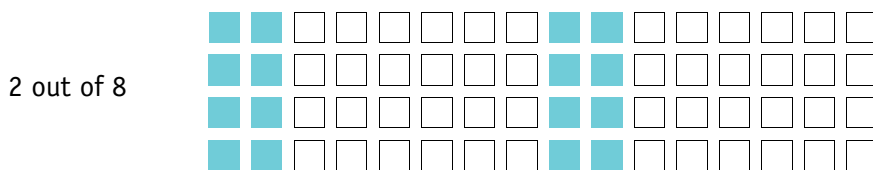

Figure 54: Horizontal sub-sampling 2 out of 8 (b/w)

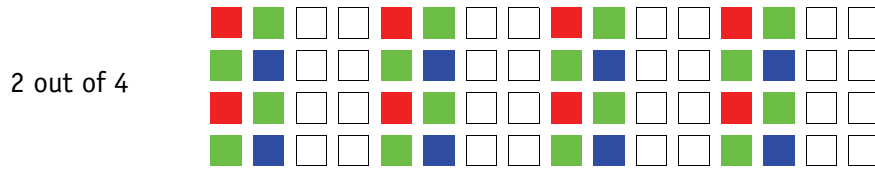

Figure 55: Horizontal sub-sampling 2 out of 4 (**color**)

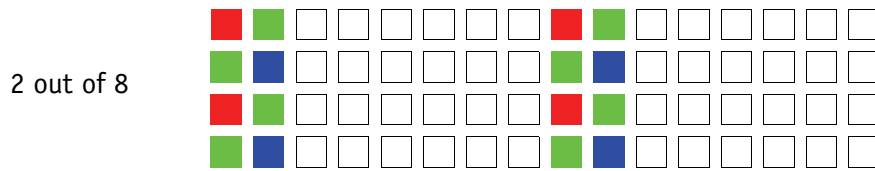

Figure 56: Horizontal sub-sampling 2 out of 8 (**color**)

Note The image appears **horizontally compressed** in this mode and no longer exhibits a true aspect ratio.



Format_7 Mode_5 By default and without further remapping use **Format_7 Mode_5** for

- Guppy PRO F-503B: 2 out of 4 vertical sub-sampling
- Guppy PRO F-503C: 2 out of 8 vertical sub-sampling

The different sub-sampling patterns are shown below.

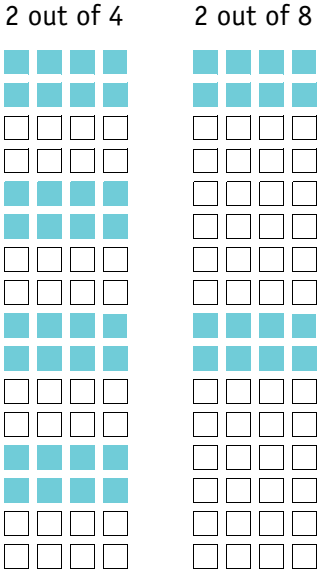

Figure 57: Vertical sub-sampling (b/w)

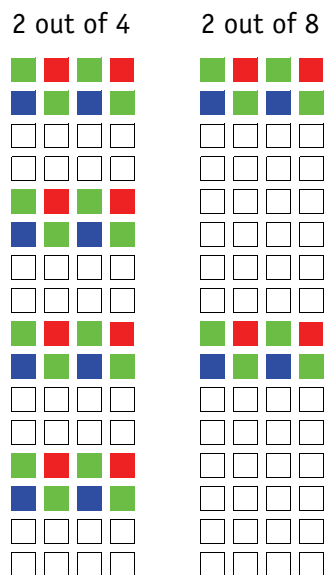

Figure 58: Vertical sub-sampling (color)

Note The image appears vertically compressed in this mode and no longer exhibits a true aspect ratio.



Format_7 Mode_6 By default and without further remapping use **Format_7 Mode_6** for 2 out of 4 H+V sub-sampling

The different sub-sampling patterns are shown below.

2 out of 4 H+V sub-sampling

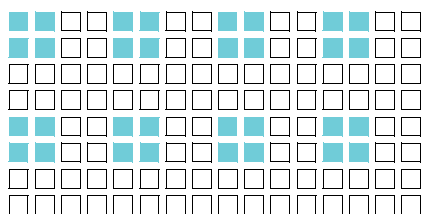

Figure 59: 2 out of 4 H+V sub-sampling (b/w)

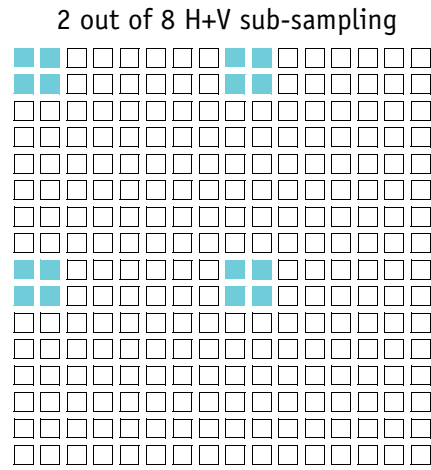

Figure 60: 2 out of 8 H+V sub-sampling (**b/w**)

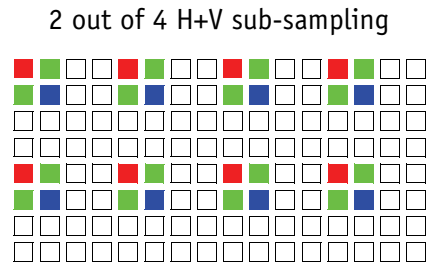

Figure 61: 2 out of 4 H+V sub-sampling (color)

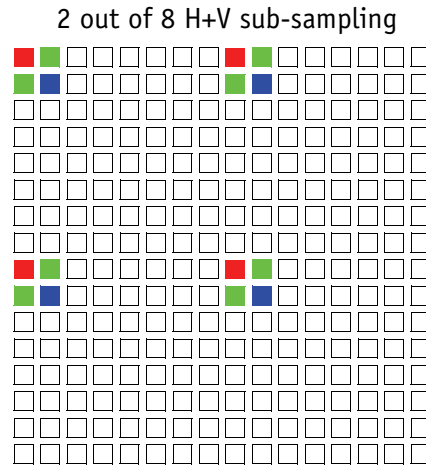

Figure 62: 2 out of 8 H+V sub-sampling (color)

Binning and sub-sampling access (F-503 only)

The binning and sub-sampling modes described in the last two chapters are only available as pure binning or pure sub-sampling modes. A combination of both is not possible.

As you can see there is a vast amount of possible combinations. But the number of available Format_7 modes is limited and lower than the possible combinations.

Thus access to the binning and sub-sampling modes is implemented in the following way:

- **Format_7 Mode_0** is fixed and cannot be changed
- A maximum of 7 individual AVT modes can be mapped to **Format_7 Mode_1 to Mode_7**

(see [Figure 63: Mapping of possible Format_7 modes to F7M1...F7M7 \(F-503 only\)](#) For default mappings per factory see [page 180](#) on [page 132](#))

- Mappings can be stored via register (see [Chapter Format_7 mode mapping \(only Guppy PRO F-503\)](#) on [page 262](#)) and are uploaded automatically into the camera on camera reset.
- The **default settings** (per factory) in the Format_7 modes are listed in the following table

Format_7	Guppy PRO monochrome	Guppy PRO color
Mode_0	full resolution, no binning, no sub-sampling	full resolution, no sub-sampling, no binning
Mode_1	2 x horizontal binning	2 x horizontal binning
Mode_2	2 x vertical binning	2 x vertical binning
Mode_3	2 x full binning	2 x full binning
Mode_4	2 out of 4 horizontal sub-sampling	2 out of 4 horizontal sub-sampling
Mode_5	2 out of 4 vertical sub-sampling	2 out of 4 vertical sub-sampling
Mode_6	2 out of 4 full sub-sampling	2 out of 4 full sub-sampling

Table 50: Default Format_7 binning and sub-sampling modes (per factory)

Note



- A **combination** of binning and sub-sampling modes is **not possible**. Use either pure binning or pure sub-sampling modes.
- The Format_ID numbers 0...27 in the binning / sub-sampling list on [page 132](#) do **not** correspond to any of the Format_7 modes.

F7 modes according to IIDC 1394	Format_ID (see p262)	AVT modes	
F7M0 (no change)	0	0 x horizontal	0 x vertical
F7M1	1	2 x horizontal	
F7M2	2	4 x horizontal	
F7M3	3	---	
F7M4	4	0 x horizontal	2 x vertical
F7M5	5	2 x horizontal	
F7M6	6	4 x horizontal	
F7M7	7	---	
	8	0 x horizontal	4 x vertical
	9	2 x horizontal	
	10	4 x horizontal	
	11	---	
	12	---	
	13	---	
	14	---	
	15	---	
	16	---	2 out of 2 vertical
	17	2 out of 4 horizontal	
	18	2 out of 8 horizontal	
	19	---	
	20	2 out of 2 horizontal	2 out of 4 vertical
	21	2 out of 4 horizontal	
	22	2 out of 8 horizontal	
	23	---	
	24	2 out of 2 horizontal	2 out of 8 vertical
	25	2 out of 4 horizontal	
	26	2 out of 8 horizontal	
	27	---	

mapping of each of 27 modes to F7M1..F7M7 possible

Figure 63: Mapping of possible Format_7 modes to F7M1...F7M7 (F-503 only)
 For default mappings per factory see page 180

Note**Configuration**

To configure this feature in an advanced register: See [Table 143: Advanced register: Format_7 mode mapping](#) on page 262.

Packed 12-Bit Mode

All Guppy PRO cameras have the so-called **Packed 12-Bit Mode**. This means: two 12-bit pixel values are packed into 3 bytes instead of 4 bytes.

B/w cameras	Color cameras
Packed 12-Bit MONO camera mode SmartView: MONO12	Packed 12-Bit RAW camera mode SmartView: RAW12
Mono and raw mode have the same implementation.	

Table 51: **Packed 12-Bit Mode**

Note

For data block packet format see [Table 38: Packed 12-Bit Mode \(mono and raw\) Y12 format \(AVT\)](#) on page 91.

For data structure see [Table 39: Data structure of Packed 12-Bit Mode \(mono and raw\) \(AVT\)](#) on page 93.

The color codings are implemented via Vendor Unique Color_Coding according to IIDC V1.31: COLOR_CODING_INQ @ 024h...033h, IDs=128-255)

See [Table 120: Format_7 control and status register](#) on page 234.

Mode	Color_Coding	ID
Packed 12-Bit MONO	ECCID_MONO12	ID=132
Packed 12-Bit RAW	ECCID_RAW12	ID=136

Table 52: **Packed 12-Bit Mode: color coding**

Color interpolation (BAYER demosaicing)

The color sensors capture the color information via so-called primary color (R-G-B) filters placed over the individual pixels in a **BAYER mosaic** layout. An effective BAYER → RGB color interpolation already takes place in all Guppy PRO color version cameras.

In color interpolation a red, green or blue value is determined for each pixel. An AVT proprietary BAYER demosaicing algorithm is used for this interpolation (2x2), optimized for both sharpness of contours as well as reduction of false edge coloring.

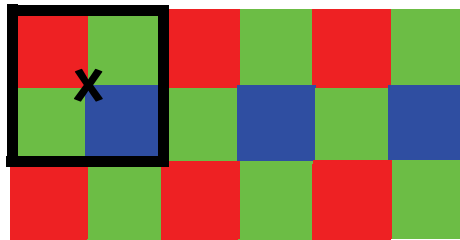

Figure 64: BAYER demosaicing (example of 2x2 matrix)

Color processing can be bypassed by using so-called RAW image transfer.

RAW mode is primarily used to

- save bandwidths on the IEEE 1394 bus
- achieve higher frame rates
- use different BAYER demosaicing algorithms on the PC (for all Guppy PRO models the first pixel of the sensor is RED).

Note

If the PC does not perform BAYER to RGB post-processing, the b/w image will be superimposed with a checkerboard pattern.



In color interpolation a red, green or blue value is determined for each pixel. Only two lines are needed for this interpolation:

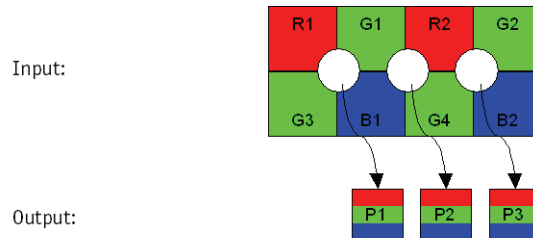

Figure 65: BAYER demosaicing (interpolation)

$$\begin{array}{lll}
 P1_{\text{red}} = R1 & P2_{\text{red}} = R2 & P3_{\text{red}} = R2 \\
 P1_{\text{green}} = \frac{G1 + G3}{2} & P2_{\text{green}} = \frac{G1 + G4}{2} & P3_{\text{green}} = \frac{G2 + G4}{2} \\
 P1_{\text{blue}} = B1 & P2_{\text{blue}} = B1 & P3_{\text{blue}} = B2
 \end{array}$$

Formula 4: BAYER demosaicing

Hue and saturation

Guppy PRO CCD and Guppy PRO F-503 color models are equipped with **hue** and **saturation** registers.

The **hue register** at offset 810h allows the color of objects to be changed without altering the white balance, by +/- 40 steps (+/- 10°) from the nominal perception. Use this setting to manipulate the color appearance after having carried out the white balance.

The **saturation register** at offset 814h allows the intensity of the colors to be changed between 0 and 200% in steps of 1/256.

This means a setting of zero changes the image to black and white and a setting of 511 doubles the color intensity compared to the nominal one at 256.

Note Configuration



To configure this feature in feature control register:
See offset [810h](#) on page 233 and [814h](#) on page 233.

Note Configuration



Hue and saturation do not show any effect on Guppy PRO color models in the Raw8 and Raw16 format, because color processing is switched off in all Raw formats.

Color correction

Why color correction?

The spectral response of a CCD is different of those of an output device or the human eye. This is the reason for the fact that perfect color reproduction is not possible. In each Guppy PRO camera there is a factory setting for the color correction coefficients, see Chapter [GretagMacbeth ColorChecker](#) on page 136.

Color correction is needed to eliminate the overlap in the color channels. This overlap is caused by the fact that:

- Blue light: is seen by the red and green pixels on the CCD
- Red light: is seen by the blue and green pixels on the CCD
- Green light: is seen by the red and blue pixels on the CCD

The color correction matrix subtracts out this overlap.

Color correction in AVT cameras

In AVT cameras the color correction is realized as an additional step in the process from the sensor data to color output.

Color correction is used to harmonize colors for the human eye.

Guppy PRO cameras have the so-called color correction matrix. This means: you are able to manipulate the color-correction coefficients yourself.

Color correction: formula

Before converting to the YUV format, color correction on all color models is carried out after BAYER demosaicing via a matrix as follows:

$$\begin{aligned} \text{red}^* &= C_{rr} \times \text{red} + C_{gr} \times \text{green} + C_{br} \times \text{blue} \\ \text{green}^* &= C_{rg} \times \text{red} + C_{gg} \times \text{green} + C_{bg} \times \text{blue} \\ \text{blue}^* &= C_{rb} \times \text{red} + C_{gb} \times \text{green} + C_{bb} \times \text{blue} \end{aligned}$$

Formula 5: Color correction

GretagMacbeth ColorChecker

Sensor-specific coefficients C_{xy} are scientifically generated to ensure that GretagMacbeth™ ColorChecker® colors are displayed with highest color fidelity and color balance.

These coefficients are stored in user set 0 and can not be overwritten (factory setting).

Changing color correction coefficients

You can change the color-correction coefficients according to your own needs. Changes are stored in the user settings.

Note



- A number of 1000 equals a color correction coefficient of 1.
- To obtain an identity matrix set values of 1000 for the diagonal elements and 0 for all others. As a result you get colors like in the RAW modes.
- The sums of all rows should be equal to each other. If not, you get tinted images.
- Color correction values range -1000 ... +2000 and are signed 32 bit.
- In order for white balance to work properly ensure that the row sum equals 1000.
- Each row should sum up to 1000. If not, images are less or more colorful.
- The maximum row sum is limited to 2000.

Note



Configuration

To configure the color-correction coefficients in an advanced register: See [Table 137: Advanced register: Color correction](#) on page 257.

To change the color-correction coefficients in **SmartView**, go to **Adv3** tab.

Switch color correction on/off

Color correction can also be switched off in YUV mode:

Note



Configuration

To configure this feature in an advanced register: See [Table 137: Advanced register: Color correction](#) on page 257.

Note



Color correction is deactivated in RAW mode.

Color conversion (RGB to YUV)

The conversion from RGB to YUV is made using the following formulae:

$$Y = 0.3 \times R + 0.59 \times G + 0.11 \times B$$

$$U = -0.169 \times R - 0.33 \times G + 0.498 \times B + 128 \text{ (@ 8 bit)}$$

$$V = 0.498 \times R - 0.420 \times G - 0.082 \times B + 128 \text{ (@ 8 bit)}$$

Formula 6: RGB to YUV conversion

Note



- As mentioned above: Color processing can be bypassed by using so-called RAW image transfer.
- RGB → YUV conversion can be bypassed by using RGB8 format and mode. This is advantageous for edge color definition but needs more bandwidth (300% instead of 200% relative to b/w or RAW consumption) for the transmission, so that the maximal frame frequency will drop.

Bulk Trigger

See Chapter [Trigger modes](#) on page 141 and the following pages.

Level Trigger

See Trigger Mode 1 in Chapter [Trigger modes](#) on page 141.

Controlling image capture

Global shutter (CCD cameras only)

- Shutter modes** The cameras support the SHUTTER_MODES specified in IIDC V1.31. For all models (except Guppy PRO F-503) this shutter is a **global shutter**; meaning that all pixels are exposed to the light at the same moment and for the same time span.
- Pipelined** Pipelined means that the shutter for a new image can already happen, while the preceding image is transmitted.
- Continuous mode** In continuous modes the shutter is opened shortly before the vertical reset happens, thus acting in a frame-synchronous way.
- External trigger** Combined with an external trigger, it becomes asynchronous in the sense that it occurs whenever the external trigger occurs. Individual images are recorded when an external trigger impulse is present. This ensures that even fast moving objects can be grabbed with no image lag and with minimal image blur.
- Software trigger** Guppy PRO cameras know also a trigger initiated by software (status and control register [62Ch](#) on page 228 or in SmartView by **Trig/I0** tab, **Stop trigger** button).
- Camera I/O** The external trigger is fed as a TTL signal through **Pin 4** of the camera I/O connector.

Electronic rolling shutter (ERS) and global reset release shutter (GRR) (only Guppy PRO F-503)

The CMOS Guppy PRO F-503 (Micron/Aptina CMOS sensor MT9P031) has an **electronic rolling shutter (ERS)** and a **global reset release shutter (GRR)** but no global shutter.

Shutter mode Guppy PRO F-503	Description
<p>Electronic rolling shutter (ERS)</p> 	<p>Advantage: designed for maximum frame rates</p> <p>How it works:</p> <ul style="list-style-type: none"> • exposure time is the same for all rows • start of exposure is different for each row <p>⇒ This can cause a shear in moving objects, see photo below.</p> <p>Customer action: Use this mode only in situations with non-moving objects.</p> 
<p>Global reset release shutter (GRR)</p> 	<p>Advantage: designed for situations with moving objects; use this mode to avoid the problems with ERS described above</p> <p>How it works: Image acquisition is done by starting all rows exposures at the same time.</p> <p>⇒ So there is no shear in moving objects.</p> <ul style="list-style-type: none"> • exposure time is different for each row • start of exposure is the same for each row <p>Customer action: Different exposure time for each row will result in images which get brighter with each row (see photo below left). In order to get an image with uniform illumination, use special lighting (flash) or mechanical/LCD extra shutter (see photo below right) which will stop the exposure of all rows simultaneously.</p> 

Table 53: Guppy PRO F-503 shutter modes

Trigger modes

Guppy PRO cameras support IIDC conforming Trigger_Mode_0 and Trigger_Mode_1 and special Trigger_Mode_15 (bulk trigger).

Note CMOS cameras Guppy PRO F-503 support only Trigger_Mode_0.

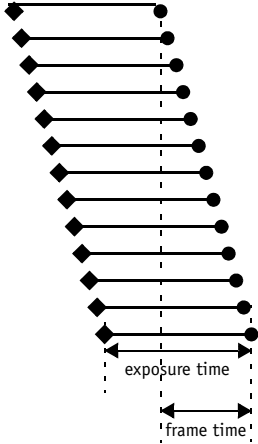
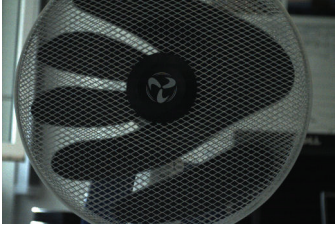
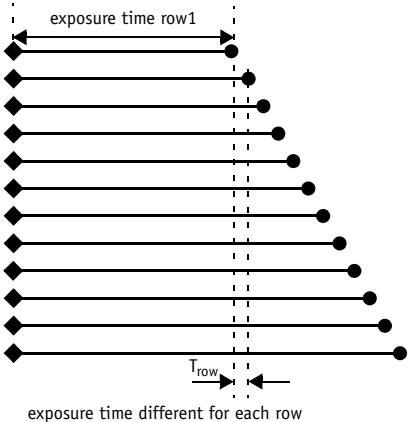
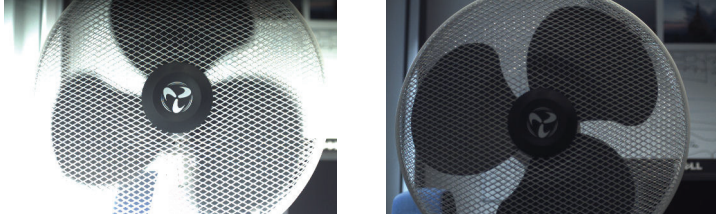

Trigger mode	also known as	Description
Trigger_Mode_0	Edge mode	Sets the shutter time according to the value set in the shutter (or extended shutter) register
Trigger_Mode_1	Level mode	Sets the shutter time according to the active low time of the pulse applied (or active high time in the case of an inverting input)
Trigger_Mode_15	Programmable mode	Is a bulk trigger , combining one external trigger event with continuous or one-shot or multi-shot internal trigger

Table 54: Trigger modes

Trigger_Mode_0 (edge mode) and Trigger_Mode_1 (level mode)

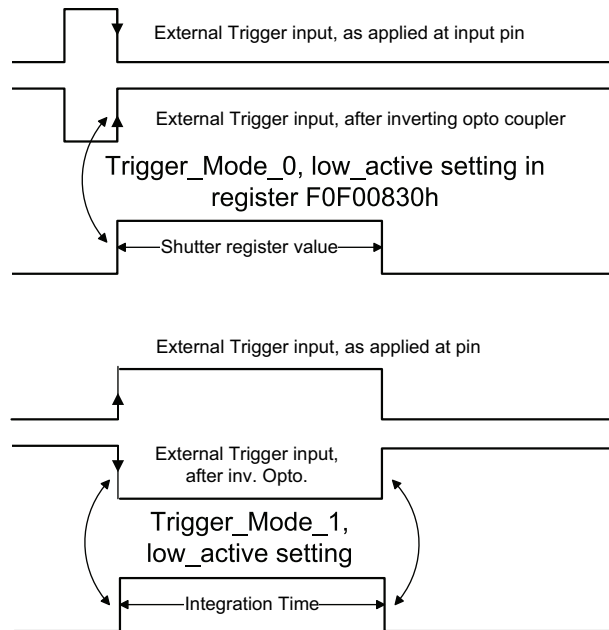

Figure 66: Trigger_Mode_0 and 1

The Guppy PRO F-503 has two shutter modes:

- electronic rolling shutter (ERS) and
- global reset release shutter (GRR)

Note With this two shutter modes only Trigger_Mode_0 is possible. Details are explained in the following diagrams.



Guppy PRO F-503, Trigger_Mode_0, electronic rolling shutter

- IntEna is high, when all pixels are integrated simultaneously.
- IntEna starts with start of exposure of last row.
- IntEna ends with end of exposure of first row.

⇒ No IntEna if exposure of first row ends before the last row starts.

Long exposure time:

To get an IntEna signal the following condition must be true:

$$T_{exp\ eff.} = T_{exp} - T_{frame} > 0$$

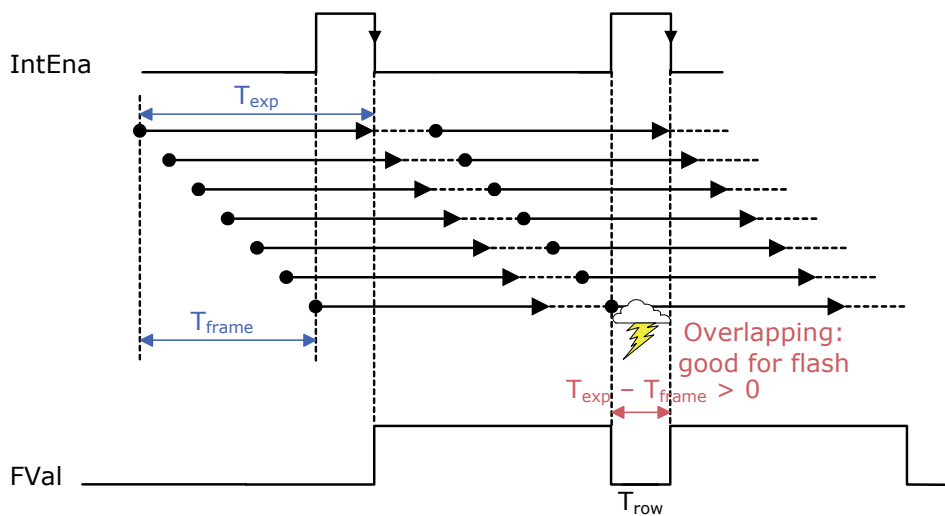

Figure 67: Trigger_Mode_0: Guppy PRO F-503 electronic rolling shutter (long exposure time)

Short exposure time:

If the following condition is true:

$$T_{\text{exp eff.}} = T_{\text{exp}} - T_{\text{frame}} < 0$$

then you don't get an IntEna signal and triggering is not possible.

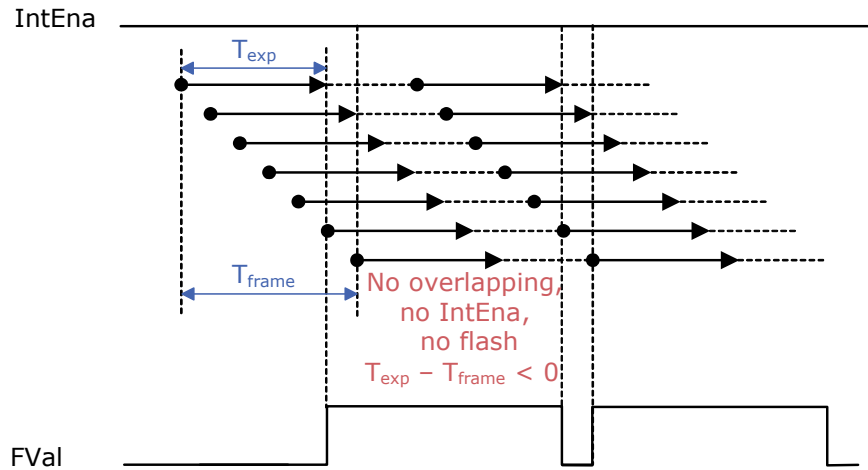

Figure 68: Trigger_Mode_0: Guppy PRO F-503 electronic rolling shutter (**short** exposure time)

Guppy PRO F-503, Trigger_Mode_0, global reset release shutter

Note



For activating **global reset release shutter** in an advanced register see [Table 149: Advanced register: Global reset release shutter](#) on page 268.

- IntEna is high, when all pixels are integrated simultaneously.
- Readout starts with end of exposure of first row.
- Readout ends with (end of exposure of last row) + (1x T_{row}).

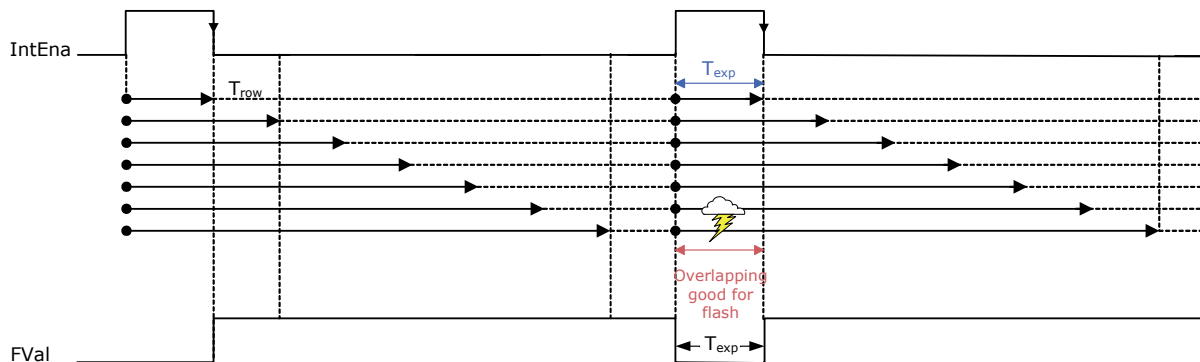

Figure 69: Trigger_Mode_0: Guppy PRO F-503: global reset release shutter

Exposure time of first row is: T_{exp}
 Exposure time of second row is: $T_{exp} + T_{row}$
 Exposure time of n-th row is: $T_{exp} + (n-1) \times T_{row}$

Thus the image gets brighter with every row. To prevent this the customer should use:

- flash (when all rows are overlapping, see drawing above)
- or a mechanical/LCD shutter

Bulk trigger (Trigger_Mode_15)

Note Trigger_Mode_15 is only available for Guppy PRO CCD cameras.



Trigger_Mode_15 is a bulk trigger, combining one external trigger event with continuous or one-shot or multi-shot internal trigger.

It is an extension to the IIDC trigger modes. One external trigger event can be used to trigger a multitude of internal image intakes.

This is especially useful for:

- Grabbing exactly one image based on the first external trigger.
- Filling the camera's internal image buffer with one external trigger without overriding images.
- Grabbing an unlimited amount of images after one external trigger (surveillance)

The figure below illustrates this mode.

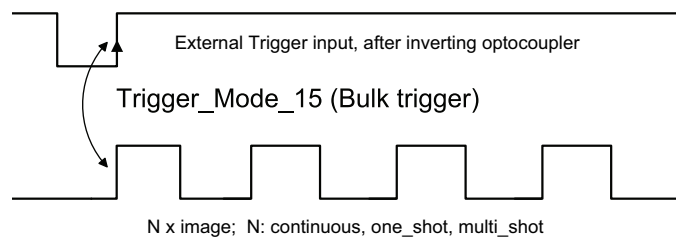

Figure 70: Trigger_Mode_15 (bulk trigger)

The functionality is controlled via bit [6] and bitgroup [12-15] of the following register:

Register	Name	Field	Bit	Description
0xF0F00830	TRIGGER_MODE	Presence_Inq	[0]	Presence of this feature: 0: N/A 1: Available
		Abs_Control	[1]	Absolute value control 0: Control with value in the Value field 1: Control with value in the Absolute value CSR If this bit = 1 the value in the Value field has to be ignored.
		---	[2..5]	Reserved
		ON_OFF	[6]	Write: ON or OFF this feature Read: read a status 0: OFF 1: ON If this bit = 0, other fields will be read only.
		Trigger_Polarity	[7]	Select trigger polarity If Polarity_Inq is 1: Write to change polarity of the trigger input. Read to get polarity of the trigger input. If Polarity_Inq is 0: Read only. 0: Low active input 1: High active input
		Trigger_Source	[8..10]	Select trigger source Set trigger source ID from trigger source ID_Inq.
		Trigger_Value	[11]	Trigger input raw signal value read only 0: Low 1: High
		Trigger_Mode	[12..15]	Trigger_Mode (Trigger_Mode_0..15)
		---	[16..19]	Reserved
		Parameter	[20..31]	Parameter for trigger function, if required (optional)

Table 55: Trigger_Mode_15 (Bulk trigger)

The screenshots below illustrate the use of Trigger_Mode_15 on a register level:

- Line #1 switches continuous mode off, leaving viewer in listen mode.
- Line #2 prepares 830h register for external trigger and Mode_15.

Left = continuous	Middle = one-shot	Right = multi-shot
Line #3 switches camera back to continuous mode. Only one image is grabbed precisely with the first external trigger. To repeat rewrite line three.	Line #3 toggles one-shot bit [0] of the one-shot register 61C so that only one image is grabbed, based on the first external trigger. To repeat rewrite line three.	Line #3 toggles multi-shot bit [1] of the one-shot register 61C so that Ah images are grabbed, starting with the first external trigger. To repeat rewrite line three.

Table 56: Description: using Trigger_Mode_15: continuous, one-shot, multi-shot

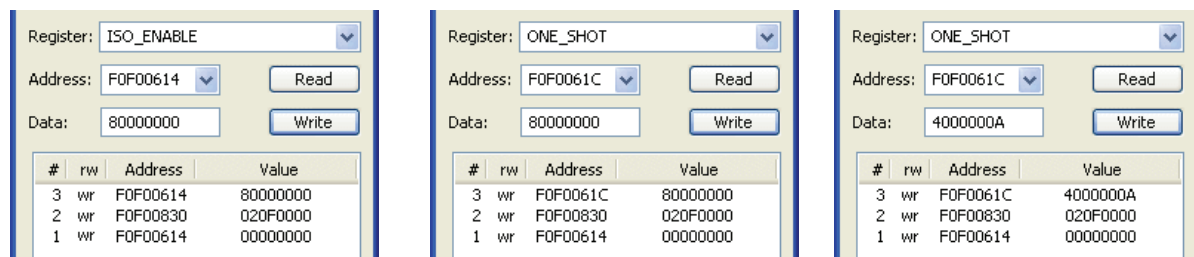

Figure 71: Using Trigger_Mode_15: continuous, one-shot, multi-shot

Note Shutter for the images is controlled by shutter register.



Trigger delay

Guppy PRO cameras feature various ways to delay image capture based on external trigger.

With IIDC V1.31 there is a standard CSR at register F0F00534/834h to control a delay up to FFFh x time base value.

The following table explains the Inquiry register and the meaning of the various bits.

Register	Name	Field	Bit	Description
0xF0F00534	TRIGGER_DLY_INQUIRY	Presence_Inq	[0]	Indicates presence of this feature (read only)
		Abs_Control_Inq	[1]	Capability of control with absolute value
		---	[2]	Reserved
		One_Push_Inq	[3]	One-push auto mode (controlled automatically by the camera once)
		ReadOut_Inq	[4]	Capability of reading out the value of this feature
		On_Off_Inq	[5]	Capability of switching this feature ON and OFF
		Auto_Inq	[6]	Auto mode (controlled automatically by the camera)
		Manual_Inq	[7]	Manual mode (controlled by user)
		Min_Value	[8..19]	Minimum value for this feature
		Max_Value	[20..31]	Maximum value for this feature

Table 57: Trigger delay inquiry register

Register	Name	Field	Bit	Description
0xF0F00834	TRIGGER_DELAY	Presence_Inq	[0]	Presence of this feature: 0: N/A 1: Available
		Abs_Control	[1]	Absolute value control 0: Control with value in the Value field 1: Control with value in the Absolute value CSR If this bit = 1, the value in the Value field has to be ignored
		---	[2..5]	Reserved
		ON_OFF	[6]	Write: ON or OFF this feature Read: read a status 0: OFF 1: ON If this bit = 0, other fields will be read only.
		---	[7..19]	Reserved
		Value	[20..31]	Value If you write the value in OFF mode, this field will be ignored. If ReadOut capability is not available, then the read value will have no meaning.

Table 58: CSR: **trigger delay**

Trigger delay advanced register

In addition, the cameras have an advanced register which allows even more precise image capture delay after receiving a hardware trigger.

Register	Name	Field	Bit	Description
0xF1000400	TRIGGER_DELAY	Presence_Inq	[0]	Indicates presence of this feature (read only)
		---	[1..5]	Reserved
		ON_OFF	[6]	Trigger delay on/off
		---	[7..10]	Reserved
		DelayTime	[11..31]	Delay time in μ s

Table 59: Advanced CSR: **trigger delay**

The advanced register allows start of the integration to be delayed by max. 2^{21} μs , which is max. 2.1 s after a trigger edge was detected.

Note



- Switching trigger delay to ON also switches external Trigger_Mode_0 to ON.
- This feature works with external Trigger_Mode_0 only.

Software trigger

A software trigger is an external signal that is controlled via a status and control register: [62Ch](#) on page 228: to activate software trigger set bit [0] to 1.

The behavior is different dependent on the trigger mode used:

- **Edge mode, programmable mode:** trigger is automatically reset (self cleared).
- **Level mode:** trigger is active until software trigger register is reset manually.
 - ⇒ in advanced register [62Ch](#) on page 228: set bit [0] to 0
 - ⇒ in SmartView: **Trig/I0** tab, **Stop trigger** button

Debounce

Only for input ports:

There is an adjustable debounce time for trigger: separate for each input pin. The debounce time is a waiting period where no new trigger is allowed. This helps you to set exact one trigger.

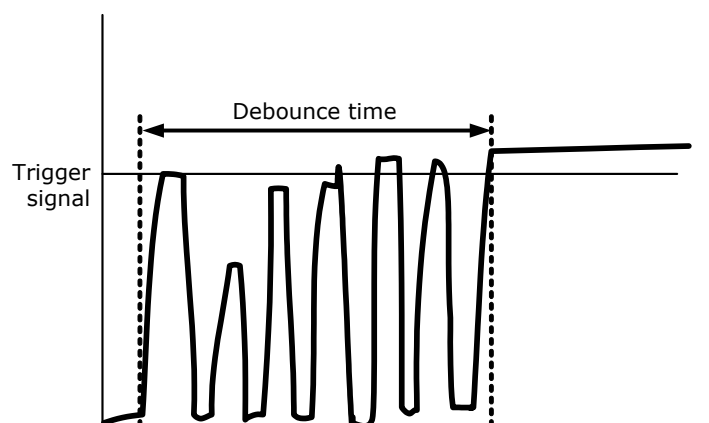

Figure 72: Example of debounce time for trigger

To set this feature in an advanced register: see Chapter [Debounce time](#) on page 152.

To set this feature in SmartView: **Trig/IO** tab, **Input pins** table, **Debounce** column.

Debounce time

This register controls the debounce feature of the cameras input pins. The debounce time can be set for each available input separately.

Increment is 500 ns

Debounce time is set in Time x 500 ns

Minimum debounce time is 1.5 μ s \Rightarrow 3 x 500 ns

Maximum debounce time is ~16 ms \Rightarrow (2¹⁵-1) x 500 ns

Offset	Name	Field	Bit	Description
0xF1000840	IO_INP_DEBOUNCE_1	Presence_Inq	[0]	Indicates presence of this feature (read only)
		---	[2..7]	Reserved
		Time	[8..31]	Debounce time in steps of 500 ns (24 bit) see examples above
0xF1000844		MinValue	[0..31]	Minimum debounce time
0xF1000848		MaxValue	[0..31]	Maximum debounce time
0xF100084C		---	[0..31]	Reserved
0xF1000850	IO_INP_DEBOUNCE_2			same as IO_INP_DEBOUNCE_1
0xF1000860	IO_INP_DEBOUNCE_3			same as IO_INP_DEBOUNCE_1
0xF1000870	IO_INP_DEBOUNCE_4			same as IO_INP_DEBOUNCE_1
0xF1000880				Reserved
0xF1000890				Reserved
0xF10008A0				Reserved
0xF10008B0				Reserved

Table 60: Advanced register: **Debounce time for input ports**

Note



- The camera corrects invalid values automatically.
- This feature is not stored in the user settings.

Exposure time (shutter) and offset

The exposure (shutter) time for continuous mode and Trigger_Mode_0 is based on the following formula:

$$\text{Shutter register value} \times \text{time base} + \text{offset}$$

The register value is the value set in the corresponding IIDC 1.31 register (SHUTTER [81Ch]). This number is in the range between 1 and 4095.

The shutter register value is multiplied by the time base register value (see [Table 128: Time base ID](#) on page 245). The default value here is set to 20 μs .

Exposure time of Guppy PRO F-503 (CMOS)

The exposure time of Guppy PRO F-503 can be set in row time increments.

The formula for the row time is:

$$t_{\text{row}} = 10.42 \text{ ns} \times \text{width} + 9.375 \mu\text{s}$$

Formula 7: Row time for Guppy PRO F-503 (CMOS)

The minimum row time and the row time by maximum resolution are:

$$\begin{aligned} t_{\text{row min}} &= 10.042 \mu\text{s} \\ t_{\text{row max res}} &= 36.375 \mu\text{s} \end{aligned}$$

Formula 8: Min. row time and row time at max. resolution for Guppy PRO F-503 (CMOS)

The shutter time of Guppy PRO F-503 can be extended via the advanced register: EXTENDED_SHUTTER

For more information see Chapter [Extended shutter](#) on page 246 and [Table 129: Advanced register: Extended shutter](#) on page 246.

Exposure time offset

A camera-specific offset is also added to this value. It is different for the camera models:

Camera model	Exposure time offset
Guppy PRO F-031	71 μ s
Guppy PRO F-032	27 μ s
Guppy PRO F-033	27 μ s
Guppy PRO F-046	27 μ s
Guppy PRO F-095	39 μ s
Guppy PRO F-125	35 μ s
Guppy PRO F-146	35 μ s
Guppy PRO F-201	45 μ s
Guppy PRO F-503	see Chapter Exposure time of Guppy PRO F-503 (CMOS) on page 153

Table 61: Camera-specific exposure time offset

Minimum exposure time

Camera model	Minimum exposure time	Effective min. exp. time = Min. exp. time + offset
Guppy PRO F-031	4 μ s	4 μ s + 71 μ s = 75 μ s
Guppy PRO F-032	10 μ s	10 μ s + 27 μ s = 37 μ s
Guppy PRO F-033	4 μ s	4 μ s + 27 μ s = 31 μ s
Guppy PRO F-046	4 μ s	4 μ s + 27 μ s = 31 μ s
Guppy PRO F-095	4 μ s	4 μ s + 39 μ s = 43 μ s
Guppy PRO F-125	4 μ s	4 μ s + 35 μ s = 39 μ s
Guppy PRO F-146	10 μ s	10 μ s + 35 μ s = 45 μ s
Guppy PRO F-201	10 μ s	10 μ s + 45 μ s = 55 μ s
Guppy PRO F-503	see Chapter Exposure time of Guppy PRO F-503 (CMOS) on page 153	

Table 62: Camera-specific minimum exposure time

Example: Guppy PRO F-031

Camera	Register value	Time base (default)
Guppy PRO F-031	100	20 μ s

Table 63: Register value and time base for **Guppy PRO F-031**

register value x time base + exposure time offset = exposure time

$100 \times 20 \mu\text{s} + 71 \mu\text{s} = 2075 \mu\text{s}$ exposure time

The minimum adjustable exposure time set by register is 4 μ s. → The real minimum exposure time of **Guppy PRO F-031** is then:

$4 \mu\text{s} + 71 \mu\text{s} = 75 \mu\text{s}$

Extended shutter

The exposure time for long-term integration of

- up to 67 seconds for the CCD models
- up to 22 seconds for the Guppy PRO F-503 (CMOS model)

can be extended via the advanced register: EXTENDED_SHUTTER

Register	Name	Field	Bit	Description
0xF100020C	EXTD_SHUTTER	Presence_Inq	[0]	Indicates presence of this feature (read only)
		---	[1.. 5]	Reserved
		ExpTime	[6..31]	Exposure time in μ s

Table 64: Advanced register: **Extended shutter**

The longest exposure time, 3FFFFFFh, corresponds to 67.11 sec.

The lowest possible value of **ExpTime** is camera-specific (see [Table 62: Camera-specific minimum exposure time](#) on page 154).

Note



- Exposure times entered via the 81Ch register are mirrored in the extended register, but not vice versa.
- Longer integration times not only increase sensitivity, but may also increase some unwanted effects such as noise and pixel-to-pixel non-uniformity. Depending on the application, these effects may limit the longest usable integration time.
- Changes in this register have immediate effect, even when the camera is transmitting.
- Extended shutter becomes inactive after writing to a format/mode/frame rate register.

One-shot

Guppy PRO cameras can record an image by setting the **one-shot bit** in the 61Ch register. This bit is automatically cleared after the image is captured. If the camera is placed in ISO_Enable mode (see Chapter [ISO_Enable / free-run](#) on page 159), this flag is ignored.

If **one-shot mode** is combined with the external trigger, the **one-shot** command is used to arm it. The following screenshot shows the sequence of commands needed to put the camera into this mode. It enables the camera to grab exactly one image with an external trigger edge.

If there is no trigger impulse after the camera has been armed, **one-shot** can be cancelled by clearing the bit.

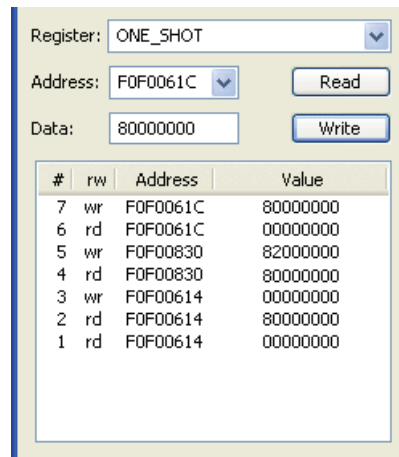

Figure 73: One-shot control (SmartView)

#	Read = rd Write = wr	Address	Value	Description
7	wr	F0F0061C	80000000	Do one-shot.
6	rd	F0F0061C	00000000	Read out one-shot register.
5	wr	F0F00830	82000000	Switch on external trigger mode 0.
4	rd	F0F00830	80000000	Check trigger status.
3	wr	F0F00614	00000000	Stop free-run.
2	rd	F0F00614	80000000	Check Iso_Enable mode (→free-run).
1	rd	F0F00614	00000000	This line is produced by SmartView.

Table 65: One-shot control: descriptions

One-shot command on the bus to start of exposure

The following sections describe the time response of the camera using a single frame (one-shot) command. As set out in the IIDC specification, this is a software command that causes the camera to record and transmit a single frame.

The following values apply only when the camera is idle and ready for use. Full resolution must also be set.

Feature	Value
One-shot → microcontroller sync	≤ 150 μs (processing time in the microcontroller)
μC-Sync/ExSync → integration start	8 μs

Table 66: Values for one-shot

Microcontroller sync is an internal signal. It is generated by the microcontroller to initiate a trigger. This can either be a direct trigger or a release for ExSync if the camera is externally triggered.

End of exposure to first packet on the bus

After the exposure, the CCD sensor is read out; some data is written into the FRAME_BUFFER before being transmitted to the bus.

The time from the end of exposure to the start of transport on the bus is:

$710 \mu\text{s} \pm 62.5 \mu\text{s}$

This time *jitters* with the cycle time of the bus (125 μs).

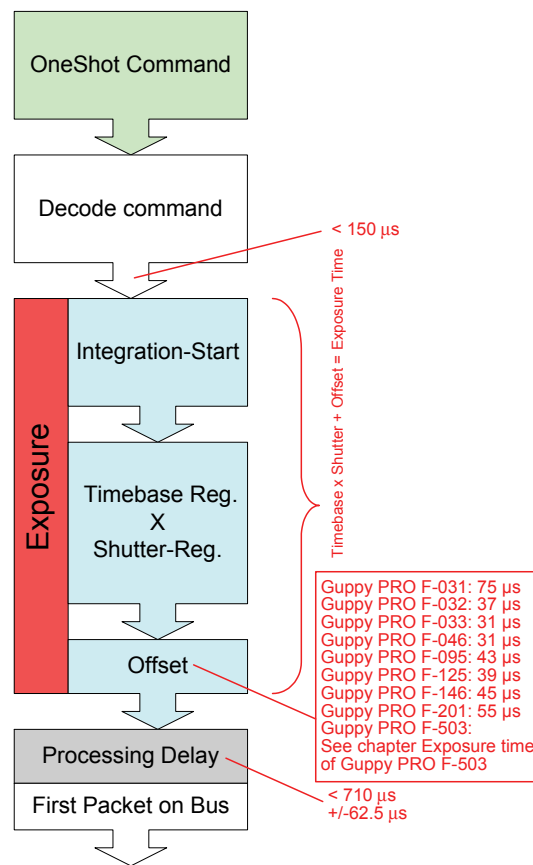

Figure 74: Data flow and timing after end of exposure

Multi-shot

Setting **multi-shot** and entering a quantity of images in **Count_Number** in the 61Ch register enables the camera to record a specified number of images.

The number is indicated in bits 16 to 31. If the camera is put into **ISO_Enable** mode (see Chapter [ISO_Enable / free-run](#) on page 159), this flag is ignored and deleted automatically once all the images have been recorded.

If **multi-shot** mode is activated and the images have not yet all been captured, it can be cancelled by resetting the flag. The same result can be achieved by setting the number of images to **0**.

Multi-shot can also be combined with the external trigger in order to grab a certain number of images based on an external trigger.

ISO_Enable / free-run

Setting the MSB (bit 0) in the 614h register (ISO_ENA) puts the camera into **ISO_Enable mode** or **Continuous_Shot (free-run)**. The camera captures an infinite series of images. This operation can be quit by deleting the **0** bit.

Asynchronous broadcast

The camera accepts asynchronous broadcasts. This involves asynchronous write requests that use node number 63 as the target node with no acknowledge.

This makes it possible for all cameras on a bus to be triggered by software simultaneously - e.g. by broadcasting a **one-shot**. All cameras receive the **one-shot** command in the same IEEE 1394 bus cycle. This creates uncertainty for all cameras in the range of 125 μ s.

Inter-camera latency is described in Chapter [Jitter at start of exposure](#) on page 160.

The following screenshot shows an example of broadcast commands sent with the Firedemo example of FirePackage:

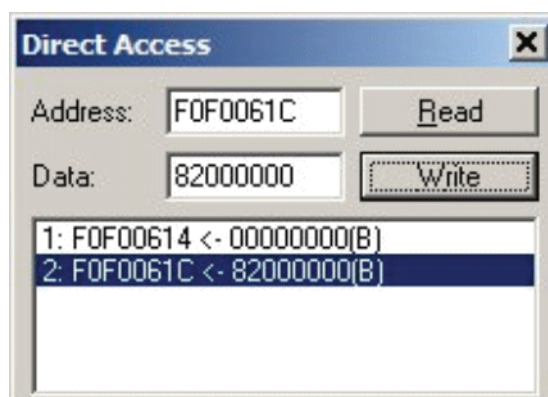

Figure 75: Broadcast one-shot

- Line 1 shows the broadcast command, which stops all cameras connected to the same IEEE 1394 bus. It is generated by holding the **Shift** key down while clicking on **Write**.
- Line 2 generates a **broadcast one_shot** in the same way, which forces all connected cameras to simultaneously grab one image.

Jitter at start of exposure

The following chapter discusses the latency time which exists for all Guppy PRO CCD models when a hardware trigger is generated, until the actual image exposure starts.

Owing to the well-known fact that an **Interline Transfer CCD** sensor has both a light sensitive area and a separate storage area, it is common to interleave image exposure of a new frame and output that of the previous one. It makes continuous image flow possible, even with an external trigger.

The uncertain time delay before the start of exposure depends on the state of the sensor. A distinction is made as follows:

FVal is active → the sensor is reading out, the camera is busy

In this case the camera must not change horizontal timing so that the trigger event is synchronized with the current horizontal clock. This introduces a maximum uncertainty which is equivalent to the line time. The line time depends on the sensor used and therefore can vary from model to model.

FVal is inactive → the sensor is ready, the camera is idle

In this case the camera can resynchronize the horizontal clock to the new trigger event, leaving only a very short uncertainty time of the master clock period.

Model	Exposure start jitter (while FVal)	Exposure start jitter (while camera idle)
Guppy PRO F-031	$\pm 14.2 \mu\text{s}$	$\pm 2.9 \mu\text{s}$
Guppy PRO F-032	$\pm 24.3 \mu\text{s}$	$\pm 3.0 \mu\text{s}$
Guppy PRO F-033	$\pm 23.4 \mu\text{s}$	$\pm 2.6 \mu\text{s}$
Guppy PRO F-046	$\pm 27.4 \mu\text{s}$	$\pm 2.6 \mu\text{s}$
Guppy PRO F-095	$\pm 35 \mu\text{s}$	$\pm 6.9 \mu\text{s}$
Guppy PRO F-125	$\pm 33.2 \mu\text{s}$	$\pm 5.0 \mu\text{s}$
Guppy PRO F-146	$\pm 56.0 \mu\text{s}$	$\pm 13.7 \mu\text{s}$
Guppy PRO F-201	$\pm 29.5 \mu\text{s}$	$\pm 10.3 \mu\text{s}$
Guppy PRO F-503	not applicable	not applicable

Table 67: Jitter at exposure start (no binning, no sub-sampling)

Note

- Jitter at the beginning of an exposure has no effect on the length of exposure, i.e. it is always constant.



Video formats, modes and bandwidth

The different Guppy PRO models support different video formats, modes and frame rates.

These formats and modes are standardized in the IIDC (formerly DCAM) specification.

Resolutions smaller than the generic sensor resolution are generated from the center of the sensor and without binning.

Note



- The maximum frame rates can only be achieved with shutter settings lower than 1/framerate. This means that with default shutter time of 40 ms, a camera will not achieve frame rates higher than 25 frames/s. In order to achieve higher frame rates, please reduce the shutter time proportionally.
- **The following tables assume that bus speed is 800 Mbit/s.** With lower bus speeds (e.g. 400, 200 or 100 Mbit/s) not all frame rates may be achieved.
- For information on bit/pixel and byte/pixel for each color mode see [Table 99: ByteDepth](#) on page 200.

Note



The following Format_7 tables show **default Format_7 modes** without Format_7 mode mapping.

For information on Format_7 mode mapping ...

- ... see Chapter [Mapping of possible Format_7 modes to F7M1...F7M7 \(F-503 only\)](#) For default mappings per factory see [page 180](#) on page 132
- ... see Chapter [Format_7 mode mapping \(only Guppy PRO F-503\)](#) on page 262

Note



H-binning means horizontal binning.

V-binning means vertical binning.

Full binning (H+V) means horizontal + vertical binning

2 x binning means: 2 neighboring pixels are combined.

4 x binning means: 4 neighboring pixels are combined.

- **Binning increases signal-to-noise ratio (SNR)**, but decreases resolution.

Guppy PRO F-031B / Guppy PRO F-031C

Format	Mode	Resolution	Color mode	240 fps	120 fps	60 fps	30 fps	15 fps	7.5 fps	3.75 fps	1.875 fps
0	0	160 x 120	YUV444								
	1	320 x 240	YUV422			x	x	x	x	x	x
	2	640 x 480	YUV411			x	x	x	x	x	x
	3	640 x 480	YUV422			x	x	x	x	x	x
	4	640 x 480	RGB8			x	x	x	x	x	x
	5	640 x 480	Mono8		x x*	x x*	x x*	x x*	x x*	x x*	x x*
	6	640 x 480	Mono16			x	x	x	x	x	x

Table 68: Video fixed formats Guppy PRO F-031B / Guppy PRO F-031C

*: Color camera outputs Mono8 interpolated image.

 Only achievable with 1394b (S800).

Note



The following table shows **default Format_7 modes** without Format_7 mode mapping.

For information on Format_7 mode mapping ...

- ... see Chapter [Mapping of possible Format_7 modes to F7M1...F7M7 \(F-503 only\)](#) For default mappings per factory see page 180 on page 132
- ... see Chapter [Format_7 mode mapping \(only Guppy PRO F-503\)](#) on page 262

Format	Mode	Resolution	Color mode	Maximal S800 frame rates for Format_7 modes
7	0	656 x 492	Mono8 Mono12 Mono16	123 fps 123 fps 120 fps
		656 x 492	YUV411 YUV422,Raw16 Mono8,Raw8 RGB8 Raw12	123 fps 101 fps 123 fps 67 fps 123 fps
	1	328 x 492	Mono8 Mono12 Mono16	123 fps 2x H-binning 123 fps 2x H-binning 123 fps 2x H-binning
	2	656 x 246	Mono8 Mono12 Mono16	205 fps 2x V-binning 205 fps 2x V-binning 188 fps 2x V-binning
	3	328 x 246	Mono8 Mono12 Mono16	205 fps 2x H+V binning 205 fps 2x H+V binning 205 fps 2x H+V binning
	4	328 x 492	Mono8 Mono12 Mono16	123 fps 2 out of 4 H-sub-sampling 123 fps 2 out of 4 H-sub-sampling 123 fps 2 out of 4 H-sub-sampling
	5	656 x 246	Mono8 Mono12 Mono16	154 fps 2 out of 4 V-sub-sampling 154 fps 2 out of 4 V-sub-sampling 154 fps 2 out of 4 V-sub-sampling
6	328 x 246	Mono8 Mono12 Mono16	154 fps 2 out of 4 H+V sub-sampling 154 fps 2 out of 4 H+V sub-sampling 154 fps 2 out of 4 H+V sub-sampling	

Table 69: Video Format_7 default modes Guppy PRO F-031B / Guppy PRO F-031C

Guppy PRO F-032B / Guppy PRO F-032C

Format	Mode	Resolution	Color mode	240 fps	120 fps	60 fps	30 fps	15 fps	7.5 fps	3.75 fps	1.875 fps
0	0	160 x 120	YUV444								
	1	320 x 240	YUV422			x	x	x	x	x	x
	2	640 x 480	YUV411			x	x	x	x	x	x
	3	640 x 480	YUV422			x	x	x	x	x	x
	4	640 x 480	RGB8			x	x	x	x	x	x
	5	640 x 480	Mono8			x x*	x x*	x x*	x x*	x x*	x x*
	6	640 x 480	Mono16			x	x	x	x	x	x

Table 70: Video fixed formats Guppy PRO F-032B / Guppy PRO F-032C

*: Color camera outputs Mono8 interpolated image.

 Only achievable with 1394b (S800).

Note



The following table shows **default Format_7 modes** without Format_7 mode mapping.

For information on Format_7 mode mapping ...

- ... see Chapter [Mapping of possible Format_7 modes to F7M1...F7M7 \(F-503 only\)](#) For default mappings per factory see page 180 on page 132
- ... see Chapter [Format_7 mode mapping \(only Guppy PRO F-503\)](#) on page 262

Format	Mode	Resolution	Color mode	Maximal S800 frame rates for Format_7 modes		
7	0	656 x 492	Mono8	82 fps		
			Mono12	82 fps		
				Mono16	82 fps	
		656 x 492	YUV411	82 fps		
	YUV422,Raw16		82 fps			
	Mono8,Raw8		82 fps			
	RGB8		66 fps			
	Raw12		82 fps			
1	328 x 492	Mono8	79 fps	2x H-binning		
		Mono12	79 fps	2x H-binning		
		Mono16	79 fps	2x H-binning		
2	656 x 246	Mono8	136 fps	2x V-binning		
		Mono12	136 fps	2x V-binning		
		Mono16	136 fps	2x V-binning		
3	328 x 246	Mono8	136 fps	2x H+V binning		
		Mono12	136 fps	2x H+V binning		
		Mono16	136 fps	2x H+V binning		
4	328 x 492	Mono8	79 fps	2 out of 4 H-sub-sampling		
		Mono12	79 fps	2 out of 4 H-sub-sampling		
		Mono16	79 fps	2 out of 4 H-sub-sampling		
5	656 x 246	Mono8	100 fps	2 out of 4 V-sub-sampling		
		Mono12	100 fps	2 out of 4 V-sub-sampling		
		Mono16	100 fps	2 out of 4 V-sub-sampling		
6	328 x 246	Mono8	100 fps	2 out of 4 H+V sub-sampling		
		Mono12	100 fps	2 out of 4 H+V sub-sampling		
		Mono16	100 fps	2 out of 4 H+V sub-sampling		

Table 71: Video Format_7 default modes Guppy PRO F-032B / Guppy PRO F-032C

Guppy PRO F-033B / Guppy PRO F-033C

Format	Mode	Resolution	Color mode	240 fps	120 fps	60 fps	30 fps	15 fps	7.5 fps	3.75 fps	1.875 fps
0	0	160 x 120	YUV444								
	1	320 x 240	YUV422			x	x	x	x	x	x
	2	640 x 480	YUV411			x	x	x	x	x	x
	3	640 x 480	YUV422			x	x	x	x	x	x
	4	640 x 480	RGB8			x	x	x	x	x	x
	5	640 x 480	Mono8			x x*	x x*	x x*	x x*	x x*	x x*
	6	640 x 480	Mono16			x	x	x	x	x	x

Table 72: Video fixed formats Guppy PRO F-033B / Guppy PRO F-033C

*: Color camera outputs Mono8 interpolated image.

 Only achievable with 1394b (S800).

Note



The following table shows **default Format_7 modes** without Format_7 mode mapping.

For information on Format_7 mode mapping ...

- ... see Chapter [Mapping of possible Format_7 modes to F7M1...F7M7 \(F-503 only\)](#) For default mappings per factory see page 180 on page 132
- ... see Chapter [Format_7 mode mapping \(only Guppy PRO F-503\)](#) on page 262

Format	Mode	Resolution	Color mode	Maximal S800 frame rates for Format_7 modes	
7	0	656 x 492	Mono8	85 fps	
			Mono12	85 fps	
		Mono16	85 fps		
	656 x 492	YUV411	85 fps		
		YUV422,Raw16	85 fps		
		Mono8,Raw8	85 fps		
		RGB8	67 fps		
		Raw12	85 fps		
1	328 x 492	Mono8	84 fps	2x H-binning	
		Mono12	84 fps	2x H-binning	
		Mono16	84 fps	2x H-binning	
2	656 x 246	Mono8	149 fps	2x V-binning	
		Mono12	149 fps	2x V-binning	
		Mono16	149 fps	2x V-binning	
3	328 x 246	Mono8	149 fps	2x H+V binning	
		Mono12	149 fps	2x H+V binning	
		Mono16	149 fps	2x H+V binning	
4	328 x 492	Mono8	84 fps	2 out of 4 H-sub-sampling	
		Mono12	84 fps	2 out of 4 H-sub-sampling	
		Mono16	84 fps	2 out of 4 H-sub-sampling	
5	656 x 246	Mono8	108 fps	2 out of 4 V-sub-sampling	
		Mono12	108 fps	2 out of 4 V-sub-sampling	
		Mono16	108 fps	2 out of 4 V-sub-sampling	
6	328 x 246	Mono8	108 fps	2 out of 4 H+V sub-sampling	
		Mono12	108 fps	2 out of 4 H+V sub-sampling	
		Mono16	108 fps	2 out of 4 H+V sub-sampling	

Table 73: Video Format_7 default modes Guppy PRO F-033B / Guppy PRO F-033C

Guppy PRO F-046B / Guppy PRO F-046C

Format	Mode	Resolution	Color mode	240 fps	120 fps	60 fps	30 fps	15 fps	7.5 fps	3.75 fps	1.875 fps
0	0	160 x 120	YUV444								
	1	320 x 240	YUV422			x	x	x	x	x	x
	2	640 x 480	YUV411			x	x	x	x	x	x
	3	640 x 480	YUV422			x	x	x	x	x	x
	4	640 x 480	RGB8			x	x	x	x	x	x
	5	640 x 480	Mono8			x x*	x x*	x x*	x x*	x x*	x x*
	6	640 x 480	Mono16			x	x	x	x	x	x

Table 74: Video fixed formats Guppy PRO F-046B / Guppy PRO F-046C

*: Color camera outputs Mono8 interpolated image.

 Only achievable with 1394b (S800).

Note



The following table shows **default Format_7 modes** without Format_7 mode mapping.

For information on Format_7 mode mapping ...

- ... see Chapter [Mapping of possible Format_7 modes to F7M1...F7M7 \(F-503 only\)](#) For default mappings per factory see page 180 on page 132
- ... see Chapter [Format_7 mode mapping \(only Guppy PRO F-503\)](#) on page 262

Format	Mode	Resolution	Color mode	Maximal S800 frame rates for Format_7 modes	
7	0	780 x 580	Mono8	62 fps	
			Mono12	41 fps	
		Mono16	30 fps		
	780 x 580	YUV411	62 fps		
		YUV422,Raw16	62 fps		
		Mono8,Raw8	62 fps		
		RGB8	48 fps		
		Raw12	62 fps		
1	388 x 580	Mono8	61 fps	2x H-binning	
		Mono12	61 fps	2x H-binning	
		Mono16	61 fps	2x H-binning	
2	780 x 290	Mono8	111 fps	2x V-binning	
		Mono12	111 fps	2x V-binning	
		Mono16	111 fps	2x V-binning	
3	388 x 290	Mono8	111 fps	2x H+V binning	
		Mono12	111 fps	2x H+V binning	
		Mono16	111 fps	2x H+V binning	
4	388 x 580	Mono8	61 fps	2 out of 4 H-sub-sampling	
		Mono12	61 fps	2 out of 4 H-sub-sampling	
		Mono16	61 fps	2 out of 4 H-sub-sampling	
5	780 x 290	Mono8	78 fps	2 out of 4 V-sub-sampling	
		Mono12	78 fps	2 out of 4 V-sub-sampling	
		Mono16	79 fps	2 out of 4 V-sub-sampling	
6	388 x 290	Mono8	79 fps	2 out of 4 H+V sub-sampling	
		Mono12	79 fps	2 out of 4 H+V sub-sampling	
		Mono16	79 fps	2 out of 4 H+V sub-sampling	

Table 75: Video Format_7 default modes Guppy PRO F-046B / Guppy PRO F-046C

Guppy PRO F-095C

Format	Mode	Resolution	Color mode	240 fps	120 fps	60 fps	30 fps	15 fps	7.5 fps	3.75 fps	1.875 fps
0	0	160 x 120	YUV444								
	1	320 x 240	YUV422				x	x	x	x	x
	2	640 x 480	YUV411				x	x	x	x	x
	3	640 x 480	YUV422				x	x	x	x	x
	4	640 x 480	RGB8				x	x	x	x	x
	5	640 x 480	Mono8				x*	x*	x*	x*	x*
	6	640 x 480	Mono16								
1	0	800 x 600	YUV422				x	x	x	x	
	1	800 x 600	RGB8				x	x	x		
	2	800 x 600	Mono8				x	x	x		
	3	1024 x 768	YUV422								
	4	1024 x 768	RGB8								
	5	1024 x 768	Mono8								
	6	800 x 600	Mono16								
	7	1024 x 768	Mono16								

Table 76: Video fixed formats Guppy PRO F-095C

*: Color camera outputs Mono8 interpolated image.

 Only achievable with 1394b (S800).

Note



The following table shows **default Format_7 modes** without Format_7 mode mapping.

For information on Format_7 mode mapping ...

- ... see Chapter [Mapping of possible Format_7 modes to F7M1...F7M7 \(F-503 only\)](#) For default mappings per factory see page 175 on page 127
- ... see Chapter [Format_7 mode mapping \(only Guppy PRO F-503\)](#) on page 254

Format	Mode	Resolution	Color mode	Maximal S800 frame rates for Format_7 modes
7	0	1280 x 720	YUV411 YUV422,Raw16 Mono8,Raw8 RGB8 Raw12	38 fps 35 fps 38 fps 23 fps 38 fps

Table 77: Video Format_7 default modes Guppy PRO F-095C

Guppy PRO F-125B / Guppy PRO F-125C

Format	Mode	Resolution	Color mode	240 fps	120 fps	60 fps	30 fps	15 fps	7.5 fps	3.75 fps	1.875 fps
0	0	160 x 120	YUV444								
	1	320 x 240	YUV422			x	x	x	x	x	x
	2	640 x 480	YUV411				x	x	x	x	x
	3	640 x 480	YUV422				x	x	x	x	x
	4	640 x 480	RGB8				x	x	x	x	x
	5	640 x 480	Mono8				x x*	x x*	x x*	x x*	x x*
	6	640 x 480	Mono16				x	x	x	x	x
1	0	800 x 600	YUV422				x	x	x	x	
	1	800 x 600	RGB8				x	x	x		
	2	800 x 600	Mono8				x x*	x x*	x x*		
	3	1024 x 768	YUV422				x	x	x	x	x
	4	1024 x 768	RGB8					x	x	x	x
	5	1024 x 768	Mono8				x x*	x x*	x x*	x x*	x x*
	6	800 x 600	Mono16				x	x	x	x	
	7	1024 x 768	Mono16				x	x	x	x	x
2	0	1280 x 960	YUV422					x	x	x	x
	1	1280 x 960	RGB8					x	x	x	x
	2	1280 x 960	Mono 8				x x*	x x*	x x*	x x*	x x*
	3	1600 x 1200	YUV422								
	4	1600 x 1200	RGB8								
	5	1600 x 1200	Mono8								
	6	1280 x 960	Mono16					x	x	x	x
	7	1600 x 1200	Mono16								

Table 78: Video fixed formats Guppy PRO F-125B / F-125C

*: Color camera outputs Mono8 interpolated image.

Frame rates with shading are only achievable with 1394b (S800).

Note

The following table shows **default Format_7 modes** without Format_7 mode mapping.



- see Chapter [Mapping of possible Format_7 modes to F7M1...F7M7 \(F-503 only\)](#) For default mappings per factory see page 180 on page 132
- see Chapter [Format_7 mode mapping \(only Guppy PRO F-503\)](#) on page 262

Format	Mode	Resolution	Color mode	Maximal S800 frame rates for Format_7 modes	
7	0	1292 x 964 1292 x 964	Mono8 Mono12 Mono16 YUV411 YUV422,Raw16 Mono8,Raw8 RGB8 Raw12	31 fps 31 fps 26 fps 31 fps 26 fps 31 fps 17 fps 31 fps	
	1	644 x 964	Mono8 Mono12 Mono16	31 fps 31 fps 31 fps	2x H-binning 2x H-binning 2x H-binning
	2	1292 x 482	Mono8 Mono12 Mono16	53 fps 53 fps 52 fps	2x V-binning 2x V-binning 2x V-binning
	3	644 x 482	Mono8 Mono12 Mono16	53 fps 53 fps 53 fps	2x H+V binning 2x H+V binning 2x H+V binning
	4	644 x 964	Mono8 Mono12 Mono16	31 fps 31 fps 31 fps	2 out of 4 H-sub-sampling 2 out of 4 H-sub-sampling 2 out of 4 H-sub-sampling
	5 [#]	1292 x 482	Mono8 Mono12 Mono16	39 fps 39 fps 39 fps	2 out of 4 V-sub-sampling 2 out of 4 V-sub-sampling 2 out of 4 V-sub-sampling
	6 [#]	644 x 482	Mono8 Mono12 Mono16	39 fps 39 fps 39 fps	2 out of 4 H+V-sub-sampling 2 out of 4 H+V-sub-sampling 2 out of 4 H+V-sub-sampling

Table 79: Video Format_7 default modes Guppy PRO F-125B / F-125C

#: Vertical sub-sampling is done via digitally concealing certain lines, so the frame rate is not
 frame rate = f (AOI height)
 but
 frame rate = f (2 x AOI height)

Guppy PRO F-146B / Guppy PRO F-146C

Format	Mode	Resolution	Color mode	240 fps	120 fps	60 fps	30 fps	15 fps	7.5 fps	3.75 fps	1.875 fps
0	0	160 x 120	YUV444								
	1	320 x 240	YUV422				x	x	x	x	x
	2	640 x 480	YUV411					x	x	x	x
	3	640 x 480	YUV422					x	x	x	x
	4	640 x 480	RGB8					x	x	x	x
	5	640 x 480	Mono8					x x*	x x*	x x*	x x*
	6	640 x 480	Mono16					x	x	x	x
1	0	800 x 600	YUV422					x	x	x	
	1	800 x 600	RGB8					x	x		
	2	800 x 600	Mono8					x x*	x x*		
	3	1024 x 768	YUV422					x	x	x	x
	4	1024 x 768	RGB8					x	x	x	x
	5	1024 x 768	Mono8					x x*	x x*	x x*	x x*
	6	800 x 600	Mono16					x	x	x	
	7	1024 x 768	Mono16					x	x	x	x
2	0	1280 x 960	YUV422					x	x	x	x
	1	1280 x 960	RGB8					x	x	x	x
	2	1280 x 960	Mono 8					x x*	x x*	x x*	x x*
	3	1600 x 1200	YUV422								
	4	1600 x 1200	RGB8								
	5	1600 x 1200	Mono8								
	6	1280 x 960	Mono16					x	x	x	x
	7	1600 x 1200	Mono16								

Table 80: Video fixed formats Guppy PRO F-146B / F-146C

*: Color camera outputs Mono8 interpolated image.

 Only achievable with 1394b (S800).

Note



The following table shows **default Format_7 modes** without Format_7 mode mapping.

- see Chapter [Mapping of possible Format_7 modes to F7M1...F7M7 \(F-503 only\)](#) For default mappings per factory see page 180 on page 132
- see Chapter [Format_7 mode mapping \(only Guppy PRO F-503\)](#) on page 262

Format	Mode	Resolution	Color mode	Maximal S800 frame rates for Format_7 modes	
7	0	1388 x 1038 1388 x 1038	Mono8 Mono12 Mono16 YUV411 YUV422,Raw16 Mono8,Raw8 RGB8 Raw12	17 fps 17 fps 17 fps 17 fps 17 fps 17 fps 15 fps 17 fps	
	1	692 x 1038	Mono8 Mono12 Mono16	17 fps 17 fps 17 fps	2x H-binning 2x H-binning 2x H-binning
	2	1388 x 518	Mono8 Mono12 Mono16	28 fps 28 fps 28 fps	2x V-binning 2x V-binning 2x V-binning
	3	692 x 518	Mono8 Mono12 Mono16	28 fps 28 fps 28 fps	2x H+V binning 2x H+V binning 2x H+V binning
	4	692 x 1038	Mono8 Mono12 Mono16	17 fps 17 fps 17 fps	2 out of 4 H-sub-sampling 2 out of 4 H-sub-sampling 2 out of 4 H-sub-sampling
	5 [#]	1388 x 518	Mono8 Mono12 Mono16	21 fps 21 fps 21 fps	2 out of 4 V-sub-sampling 2 out of 4 V-sub-sampling 2 out of 4 V-sub-sampling
	6 [#]	692 x 518	Mono8 Mono12 Mono16	21 fps 21 fps 21 fps	2 out of 4 H+V-sub-sampling 2 out of 4 H+V-sub-sampling 2 out of 4 H+V-sub-sampling

Table 81: Video Format_7 default modes Guppy PRO F-146B / F-146C

#: Vertical sub-sampling is done via digitally concealing certain lines, so the frame rate is not
 frame rate = f (AOI height)
 but
 frame rate = f (2 x AOI height)

Guppy PRO F-201B / Guppy PRO F-201C

Format	Mode	Resolution	Color mode	240 fps	120 fps	60 fps	30 fps	15 fps	7.5 fps	3.75 fps	1.875 fps
0	0	160 x 120	YUV444								
	1	320 x 240	YUV422				x	x	x	x	x
	2	640 x 480	YUV411				x	x	x	x	x
	3	640 x 480	YUV422				x	x	x	x	x
	4	640 x 480	RGB8				x	x	x	x	x
	5	640 x 480	Mono 8				x x*	x x*	x x*	x x*	x x*
	6	640 x 480	Mono 16				x	x	x	x	x
1	0	800 x 600	YUV422					x	x	x	
	1	800 x 600	RGB8					x	x		
	2	800 x 600	Mono8					x x*	x x*		
	3	1024 x 768	YUV422					x	x	x	x
	4	1024 x 768	RGB8					x	x	x	x
	5	1024 x 768	Mono 8					x x*	x x*	x x*	x x*
	6	800 x 600	Mono16					x	x	x	
	7	1024 x 768	Mono16					x	x	x	x
2	0	1280 x 960	YUV422					x	x	x	x
	1	1280 x 960	RGB8					x	x	x	x
	2	1280 x 960	Mono 8					x x*	x x*	x x*	x x*
	3	1600 x 1200	YUV422						x	x	x
	4	1600 x 1200	RGB8						x	x	x
	5	1600 x 1200	Mono8						x x*	x x*	x x*
	6	1280 x 960	Mono16					x	x	x	x
	7	1600 x 1200	Mono16						x	x	x

Table 82: Video fixed formats Guppy PRO F-201B / F-201C

*: Color camera outputs Mono8 interpolated image.

Only achievable with 1394b (S800).

Note

The following table shows **default Format_7 modes** without Format_7 mode mapping.



- see Chapter [Binning and sub-sampling access \(F-503 only\)](#) on page 130
- see [Table 50: Default Format_7 binning and sub-sampling modes \(per factory\)](#) on page 131

Format	Mode	Resolution	Color mode	Maximal S800 frame rates for Format_7 modes	
7	0	1624 x 1234 1624 x 1234	Mono8 Mono12 Mono16 YUV411 YUV422,Raw16 Mono8,Raw8 RGB8 Raw12	14 fps 14 fps 14 fps 14 fps 14 fps 14 fps 12 fps 14 fps	
	1	812 x 1234	Mono8 Mono12 Mono16	14 fps 14 fps 14 fps	2x H-binning 2x H-binning 2x H-binning
	2	1624 x 616	Mono8 Mono12 Mono16	24 fps 24 fps 24 fps	2x V-binning 2x V-binning 2x V-binning
	3	812 x 616	Mono8 Mono12 Mono16	24 fps 24 fps 24 fps	2x H+V binning 2x H+V binning 2x H+V binning
	4	812 x 1234	Mono8 Mono12 Mono16	14 fps 14 fps 14 fps	2 out of 4 H-sub-sampling 2 out of 4 H-sub-sampling 2 out of 4 H-sub-sampling
7	5#	1624 x 616	Mono8 Mono12 Mono16	17 fps 17 fps 17 fps	2 out of 4 V-sub-sampling 2 out of 4 V-sub-sampling 2 out of 4 V-sub-sampling
	6#	812 x 616	Mono8 Mono12 Mono16	17 fps 17 fps 17 fps	2 out of 4 H+V sub-sampling 2 out of 4 H+V sub-sampling 2 out of 4 H+V sub-sampling

Table 83: Video Format_7 default modes Guppy PRO F-201B / F-201C

#: Vertical sub-sampling is done via digitally concealing certain lines, so the frame rate is not

frame rate = f (AOI height)

but

frame rate = f (2 x AOI height)

Guppy PRO F-503B / Guppy PRO F-503C

F0M2 (120 fps), F0M5 (120 fps), F1M5 (60 fps) are only available with **electronic rolling shutter** (whereas present in both shutter modes). If using **global reset release shutter** the camera runs these modes with **half** frame rates only.

Format Mode	Resolution	Color mode	120 fps	60 fps	30 fps	15 fps	7.5 fps	3.75 fps	1.875 fps	
0	0	160 x 120								
	1	320 x 240	X	X	X	X	X	X	X	
	2	640 x 480	X	X	X	X	X	X	X	
	3	640 x 480		X	X	X	X	X	X	
	4	640 x 480								
	5	640 x 480	MONO8	X X*	X X*	X X*	X X*	X X*	X X*	X X*
	6	640 x 480	MONO16		X	X	X	X	X	X
1	0	800 x 600		X	X	X	X	X		
	1	800 x 600								
	2	800 x 600		X X*	X X*	X X*	X X*			
	3	1024 x 768			X	X	X	X	X	
	4	1024 x 768	RGB8							
	5	1024 x 768	MONO8		X X*	X X*	X X*	X X*	X X*	X X*
	6	800 x 600	MONO16		X	X	X	X		
	7	1024 x 768	MONO16			X	X	X	X	
2	0	1280 x 960				X	X	X	X	
	1	1280 x 960								
	2	1280 x 960			X X*	X X*	X X*	X X*	X X*	
	3	1600 x1200				X	X	X	X	
	4	1600 x1200	RGB8							
	5	1600 x1200	Mono8				X X*	X X*	X X*	X X*
	6	1280 x 960	Mono16				X	X	X	X
	7	1600 x1200	Mono16				X	X	X	X

Table 84: Video formats Guppy PRO F-503B / Guppy PRO F-503C

*: Color camera outputs Mono8 interpolated image.

Only achievable with 1394b (S800).

Note



The following table shows **default Format_7 modes** without Format_7 mode mapping.

- see Chapter [Mapping of possible Format_7 modes to F7M1...F7M7 \(F-503 only\)](#) For default mappings per factory see page 180 on page 132
- see Chapter [Format_7 mode mapping \(only Guppy PRO F-503\)](#) on page 262

Format	Mode	Resolution	Color mode	Maximal S800 frame rates for Format_7 modes	
7	0	2588 x 1940 2588 x 1940	Mono8 Mono12 Mono16 Mono8,Raw8 YUV411,Raw12 YUV422,Raw16	13.04 fps 8.69 fps 6.52 fps 13.04 fps 8.69 fps 6.52 fps	
	1	1292 x 1940 1292 x 1944	Mono8 Mono12 Mono16 Mono8,Raw8 YUV411,Raw12 YUV422,Raw16	22.76 fps 17.41 fps 13.06 fps 22.76 fps 17.41 fps 13.06 fps	2x H-binning 2x H-binning 2x H-binning 2x H-binning 2x H-binning 2x H-binning
	2	2588 x 968 2588 x 968	Mono8 Mono12 Mono16 Mono8,Raw8 YUV411,Raw12 YUV422,Raw16	23.36 fps 17.41 fps 13.06 fps 23.36 fps 17.41 fps 13.06 fps	2x V-binning 2x V-binning 2x V-binning 2x V-binning 2x V-binning 2x V-binning
	3	1292 x 968 1292 x 968	Mono8 Mono12 Mono16 Mono8,Raw8 YUV411,Raw12 YUV422,Raw16	34.26 fps 34.26 fps 26.10 fps 34.26 fps 34.26 fps 26.10 fps	2x H+V binning 2x H+V binning 2x H+V binning 2x H+V binning 2x H+V binning 2x H+V binning
	4	1292 x 1940 1292 x 1940	Mono8 Mono12 Mono16 Mono8,Raw8 YUV411,Raw12 YUV422,Raw16	22.32 fps 17.41 fps 13.06 fps 22.32 fps 17.41 fps 13.06 fps	2x H-sub-sampling 2x H-sub-sampling 2x H-sub-sampling 2x H-sub-sampling 2x H-sub-sampling 2x H-sub-sampling
	5	2588 x 968 2588 x 968	Mono8 Mono12 Mono16 Mono8,Raw8 YUV411,Raw12 YUV422,Raw16	26.10 fps 17.41 fps 13.06 fps 26.10 fps 17.41 fps 13.06 fps	2x V-sub-sampling 2x V-sub-sampling 2x V-sub-sampling 2x V-sub-sampling 2x V-sub-sampling 2x V-sub-sampling
	6	1292 x 968 1292 x 968	Mono8 Mono12 Mono16 Mono8,Raw8 YUV411,Raw12 YUV422,Raw16	44.32 fps 34.71 fps 26.10 fps 44.32 fps 34.71 fps 26.10 fps	2x H+V sub-sampling 2x H+V sub-sampling 2x H+V sub-sampling 2x H+V sub-sampling 2x H+V sub-sampling 2x H+V sub-sampling

Table 85: Video Format_7 default modes Guppy PRO F-503B / F-503C

Area of interest (AOI)

The camera's image sensor has a defined resolution. This indicates the maximum number of lines and pixels per line that the recorded image may have. However, often only a certain section of the entire image is of interest. The amount of data to be transferred can be decreased by limiting the image to a section when reading it out from the camera. At a lower vertical resolution the sensor can be read out faster and thus the frame rate is increased.

Note The setting of AOIs is supported only in video Format_7.



While the size of the image read out for most other video formats and modes is fixed by the IIDC specification, thereby determining the highest possible frame rate, in Format_7 mode the user can set the **upper left corner** and **width and height** of the section (area of interest = AOI) he is interested in to determine the size and thus the highest possible frame rate.

Setting the AOI is done in the IMAGE_POSITION and IMAGE_SIZE registers.

Note Pay attention to the increments entering in the UNIT_SIZE_INQ and UNIT_POSITION_INQ registers when configuring IMAGE_POSITION and IMAGE_SIZE.



AF_AREA_POSITION and AF_AREA_SIZE contain in the respective bits values for the column and line of the upper left corner and values for the width and height.

Note For more information see [Table 120: Format_7 control and status register](#) on page 234.



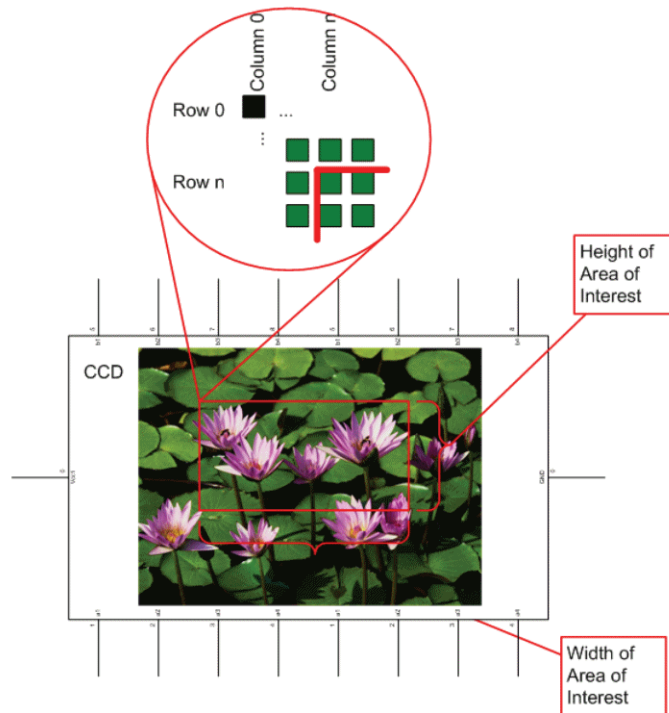

Figure 76: Area of interest (AOI)

Note



- The left position + width and the upper position + height may not exceed the maximum resolution of the sensor.
- The coordinates for width and height must be divisible by 4.

In addition to the area of interest (AOI), some other parameters have an effect on the maximum frame rate:

- The time for reading the image from the sensor and transporting it into the FRAME_BUFFER
- The time for transferring the image over the FireWire™ bus
- The length of the exposure time.

Autofunction AOI

Use this feature to select the image area (work area) on which the following autofunctions work:

- Auto shutter
- Auto gain
- Auto white balance

In the following screenshot you can see an example of the autofunction AOI:

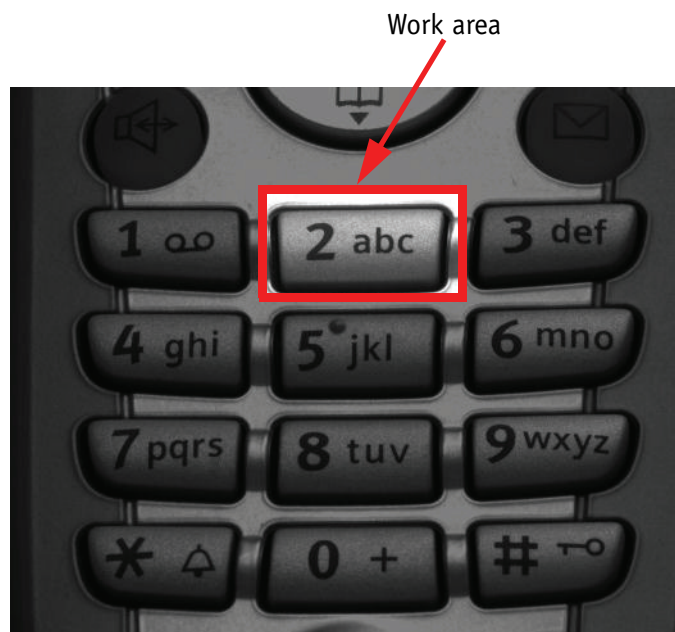

Figure 77: Example of autofunction AOI (*Show work area* is on)

Note



Autofunction AOI is independent from Format_7 AOI settings.

If you switch off autofunction AOI, work area position and work area size follow the current active image size.

To switch off autofunctions, carry out following actions in the order shown:

1. Uncheck **Show AOI** check box (SmartView **Ctrl2** tab).
2. Uncheck **Enable** check box (SmartView **Ctrl2** tab).
Switch off Auto modes (e.g. **Shutter** and/or **Gain**) (SmartView **Ctrl2** tab).

As a reference it uses a grid of up to 65534 sample points equally spread over the AOI.

Note**Configuration**

To configure this feature in an advanced register see Chapter [Autofunction A0I](#) on page 256.

Frame rates

An IEEE 1394 camera requires bandwidth to transport images.

The IEEE 1394b bus has very large bandwidth of at least 62.5 MByte/s for transferring (isochronously) image data. Per cycle up to 8192 bytes (or around 2000 quadlets = 4 bytes@ 800 Mbit/s) can thus be transmitted.

Note

All bandwidth data is calculated with:

1 MByte = 1024 kByte

Depending on the video format settings and the configured frame rate, the camera requires a certain percentage of maximum available bandwidth. Clearly the bigger the image and the higher the frame rate, the more data is to be transmitted.

The following tables indicate the volume of data in various formats and modes to be sent within one cycle (125 μ s) at 800 Mbit/s of bandwidth.

The tables are divided into three formats:

Format	Resolution	Max. video format
Format_0	up to VGA	640 x 480
Format_1	up to XGA	1024 x 768
Format_2	up to UXGA	1600 x 1200

Table 86: Overview fixed formats

They enable you to calculate the required bandwidth and to ascertain the number of cameras that can be operated independently on a bus and in which mode.

Format	Mode	Resolution	240 fps	120 fps	60 fps	30 fps	15 fps	7.5 fps	3.75 fps
0	0	160 x 120 YUV (4:4:4) 24 bit/pixel	4H 640p 480q	2H 320p 240q	1H 160p 120q	1/2H 80p 60q	1/4H 40p 30q	1/8H 20p 15q	
	1	320 x 240 YUV (4:2:2) 16 bit/pixel	8H 2560p 1280q	4H 1280p 640q	2H 640p 320q	1H 320p 160q	1/2H 160p 80q	1/4H 80p 40q	1/8H 40p 20q
	2	640 x 480 YUV (4:1:1) 12 bit/pixel		8H 5120p 1920q	4H 2560p 960q	2H 1280p 480q	1H 640p 240q	1/2H 320p 120q	1/4H 160p 60q
	3	640 x 480 YUV (4:2:2) 16 bit/pixel			4H 2560p 1280q	2H 1280p 640q	1H 640p 320q	1/2H 320p 160q	1/4H 160p 80q
	4	640 x 480 RGB 24 bit/pixel			4H 2560p 1280q	2H 1280p 960q	1H 640p 480q	1/2H 320p 240q	1/4H 160p 120q
	5	640 x 480 (Mono8) 8 bit/pixel		8H 5120p 1280q	4H 2560p 640q	2H 1280p 320q	1H 640p 160q	1/2H 320p 80q	1/4H 160p p40q
	6	640 x 480 Y (Mono16) 16 bit/pixel			4H 2560p 1280q	2H 1280p 640q	1H 640p 320q	1/2H 320p 160q	1/4H 160p 80q
	7	Reserved							

Table 87: Format_0

As an example, VGA Mono8 @ 60 fps requires four lines (640 x 4 = 2560 pixels/byte) to transmit every 125 μ s: this is a consequence of the sensor's line time of about 30 μ s, so that no data needs to be stored temporarily.

It takes 120 cycles (120 x 125 μ s = 15 ms) to transmit one frame, which arrives every 16.6 ms from the camera. Again no data need to be stored temporarily.

Thus around 64% of the available bandwidth (at S400) is used. Thus one camera can be connected to the bus at S400.

The same camera, run at S800 would require only 32% of the available bandwidth, due to the doubled speed. Thus up to three cameras can be connected to the bus at S800.

Format	Mode	Resolution	240 fps	120 fps	60 fps	30 fps	15 fps	7.5 fps	3.75 fps	1.875 fps
1	0	800 x 600 YUV (4:2:2) 16 bit/pixel			5H 4000p 2000q	5/2H 2000p 1000q	5/4H 1000p 500q	5/8H 500p 250q	6/16H 250p 125q	
	1	800 x 600 RGB 24 bit/pixel				5/2H 2000p 1500q	5/4H 1000p 750q	5/8H 500p 375q		
	2	800 x 600 Y (Mono8) 8 bit/pixel		10H 8000p 2000q	5H 4000p 1000q	5/2H 2000p 500q	5/4H 1000p 250q	5/8H 500p 125q		
	3	1024 x 768 YUV (4:2:2) 16 bit/pixel				3H 3072p 1536q	3/2H 1536p 768q	3/4H 768p 384q	3/8H 384p 192q	3/16H 192p 96q
	4	1024 x 768 RGB 24 bit/pixel					3/2H 1536p 384q	3/4H 768p 576q	3/8H 384p 288q	3/16H 192p 144q
	5	1024 x 768 Y (Mono) 8 bit/pixel			6H 6144p 1536q	3H 3072p 768q	3/2H 1536p 384q	3/4H 768p 192q	3/8H 384p 96q	3/16H 192p 48q
	6	800 x 600 (Mono16) 16 bit/pixel			5H 4000p 2000q	5/2H 2000p 1000q	5/4H 1000p 500q	5/8H 500p 250q	5/16H 250p 125q	
	7	1024 x 768 Y (Mono16) 16 bit/pixel				3H 3072p 1536q	3/2H 1536p 768q	3/4H 768p 384q	3/8H 384p 192q	3/16H 192p 96q

Table 88: Format_1

Format	Mode	Resolution	60 fps	30 fps	15 fps	7.5 fps	3.75 fps	1.875 fps
2	0	1280 x 960 YUV (4:2:2) 16 bit/pixel			2H 2560p 1280q	1H 1280p 640q	1/2H 640p 320q	1/4H 320p 160q
	1	1280 x 960 RGB 24 bit/pixel			2H 2560p 1920q	1H 1280p 960q	1/2H 640p 480q	1/4H 320p 240q
	2	1280 x 960 Y (Mono8) 8 bit/pixel		4H 5120p 1280q	2H 2560p 640q	1H 1280p 320q	1/2H 640p 160q	1/4H 320p 80q
	3	1600 x 1200 YUV(4:2:2) 16 bit/pixel			5/2H 4000p 2000q	5/4H 2000p 1000q	5/8H 1000p 500q	5/16H 500p 250q
	4	1600 x 1200 RGB 24 bit/pixel				5/4H 2000p 1500q	5/8H 1000p 750q	5/16 500p 375q
	5	1600 x 1200 Y (Mono) 8 bit/pixel		5H 8000p 2000q	5/2H 4000p 1000q	5/4H 2000p 500q	5/8H 1000p 250q	5/16H 500p 125q
	6	1280 x 960 Y (Mono16) 16 bit/pixel			2H 2560p 1280q	1H 1280p 640q	1/2H 640p 320q	1/4H 320p 160q
	7	1600 x 1200Y(Mono16) 16 bit/pixel			5/2H 4000p 2000q	5/4H 2000p 1000q	5/8H 1000p 500q	5/16H 500p 250q

Table 89: Format_2

As already mentioned, the recommended limit for transferring isochronous image data is 2000q (quadlets) per cycle or 8192 bytes (with 800 Mbit/s of bandwidth).

Note



- If the cameras are operated with an external trigger the maximum trigger frequency may not exceed the highest continuous frame rate, so preventing frames from being dropped or corrupted.
- IEEE 1394 adapter cards with PCIlynx™ chipsets (predecessor of OHCI) have a limit of 4000 bytes per cycle.

The frame rates in video modes 0 to 2 are specified and set fixed by IIDC V1.31.

Frame rates Format_7

In video Format_7 frame rates are no longer fixed.

Note



- Different values apply for the different sensors.
- Frame rates may be further limited by longer shutter times and/or bandwidth limitation from the IEEE 1394 bus.

Details are described in the next chapters:

- Max. frame rate of CCD (theoretical formula)
- Diagram of frame rates as function of AOI by constant width: the curves describe RAW8, RAW12/YUV411, RAW16/YUV422, RGB8 and max. frame rate of CCD
- Table with max. frame rates as function of AOI by constant width

Guppy PRO F-031: AOI frame rates

$$\text{max. frame rate of CCD} = \frac{1}{148.71\mu\text{s} + \text{AOI height} \times 16.05\mu\text{s} + (508 - \text{AOI height}) \times 2.93\mu\text{s}}$$

Formula 9: **Guppy PRO F-031**: theoretical max. frame rate of CCD

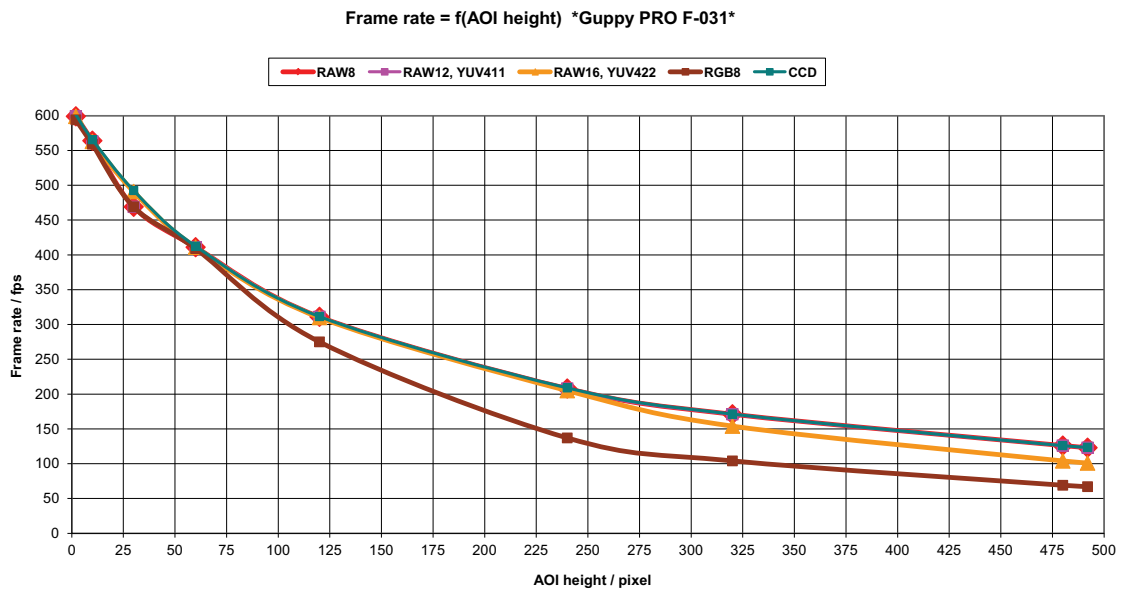

Figure 78: Frame rates **Guppy PRO F-031** as function of AOI height [**width=656**]

AOI height	CCD*	Raw8	Raw12	Raw16	YUV411	YUV422	RGB8
492	123.58	123	123	101	123	101	67
480	126.03	126	126	104	126	104	69
320	171.36	171	171	154	171	154	104
240	208.94	208	208	205	208	205	137
120	311.38	311	311	310	310	309	275
60	412.48	411	411	411	410	409	409
30	492.43	469	469	491	469	488	469
10	565.50	564	564	563	560	559	559
2	601.18	599	599	599	594	594	594

Table 90: Frame rates (fps) of **Guppy PRO F-031** as function of AOI height (pixel) [**width=656**]

* CCD = theoretical max. frame rate (in fps) of CCD according to given formula

Guppy PRO F-032: AOI frame rates

$$\text{max. frame rate of CCD} = \frac{1}{167.06\mu\text{s} + \text{AOI height} \times 24.31\mu\text{s} + (492 - \text{AOI height}) \times 2.97\mu\text{s}}$$

Formula 10: **Guppy PRO F-032**: theoretical max. frame rate of CCD

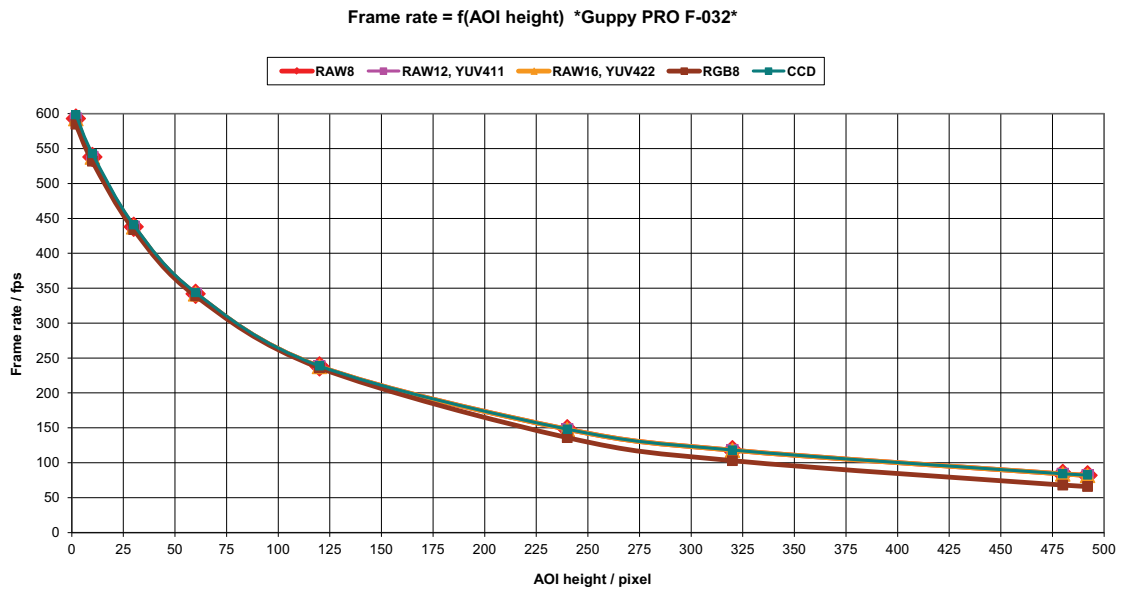

Figure 79: Frame rates **Guppy PRO F-032** as function of AOI height [width=656]

AOI height	CCD*	RAW8	RAW12	RAW16	YUV411	YUV422	RGB8
492	82.46	82	82	82	82	82	66
480	84.24	84	84	84	83	83	68
320	118.24	118	118	118	118	118	103
240	148.15	148	148	148	146	146	136
120	238.71	238	238	238	236	236	236
60	343.80	342	342	342	339	339	339
30	440.82	438	438	438	434	434	434
10	542.98	538	538	538	532	532	532
2	598.45	593	593	593	585	585	585

Table 91: Frame rates (fps) of **Guppy PRO F-032** as function of AOI height (pixel) [width=656]

* CCD = theoretical max. frame rate (in fps) of CCD according to given formula

Guppy PRO F-033: AOI frame rates

$$\text{max. frame rate of CCD} = \frac{1}{186.50\mu\text{s} + \text{AOI height} \times 23.41\mu\text{s} + (505 - \text{AOI height}) \times 2.59\mu\text{s}}$$

Formula 11: **Guppy PRO F-033**: theoretical max. frame rate of CCD

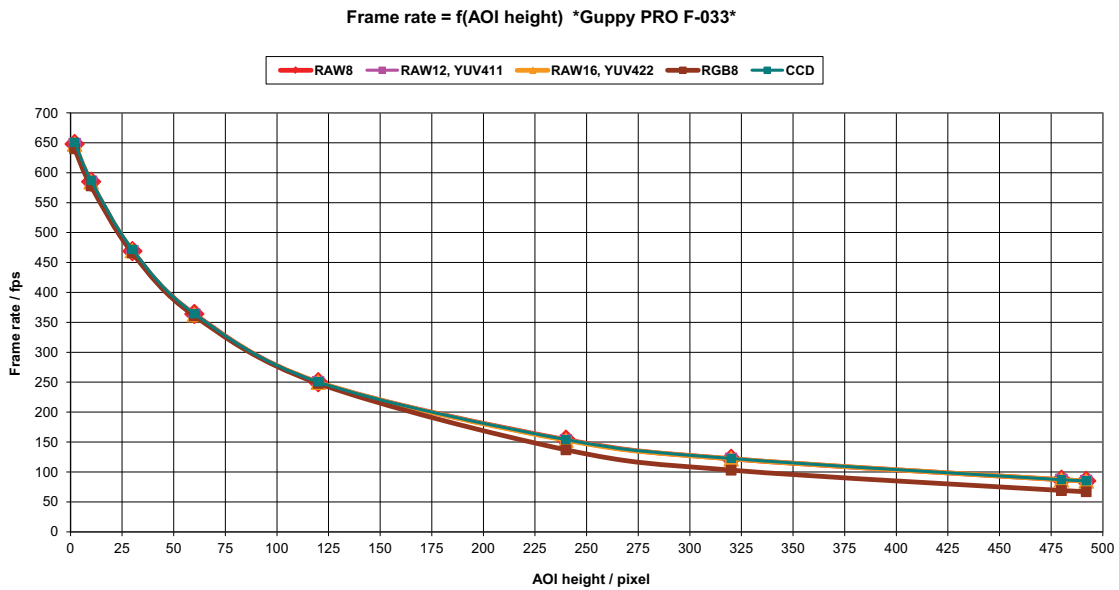

Figure 80: Frame rates **Guppy PRO F-033** as function of AOI height [**width=656**]

AOI height	CCD*	RAW8	RAW12	RAW16	YUV411	YUV422	RGB8
492	85.19	85	85	85	85	85	67
480	87.04	87	87	87	87	87	69
320	122.59	122	122	122	122	122	103
240	154.05	154	153	153	153	153	137
120	250.44	250	250	250	248	248	248
60	364.47	364	363	363	361	361	361
30	471.91	469	469	470	466	466	466
10	587.32	585	585	585	578	578	578
2	651.00	648	648	648	640	640	640

Table 92: Frame rates (fps) of **Guppy PRO F-033** as function of AOI height (pixel) [**width=656**]

* CCD = theoretical max. frame rate (in fps) of CCD according to given formula

Guppy PRO F-046: AOI frame rates

$$\text{max. frame rate of CCD} = \frac{1}{206.20\mu\text{s} + \text{AOI height} \times 27.35\mu\text{s} + (593 - \text{AOI height}) \times 2.59\mu\text{s}}$$

Formula 12: **Guppy PRO F-046**: theoretical max. frame rate of CCD

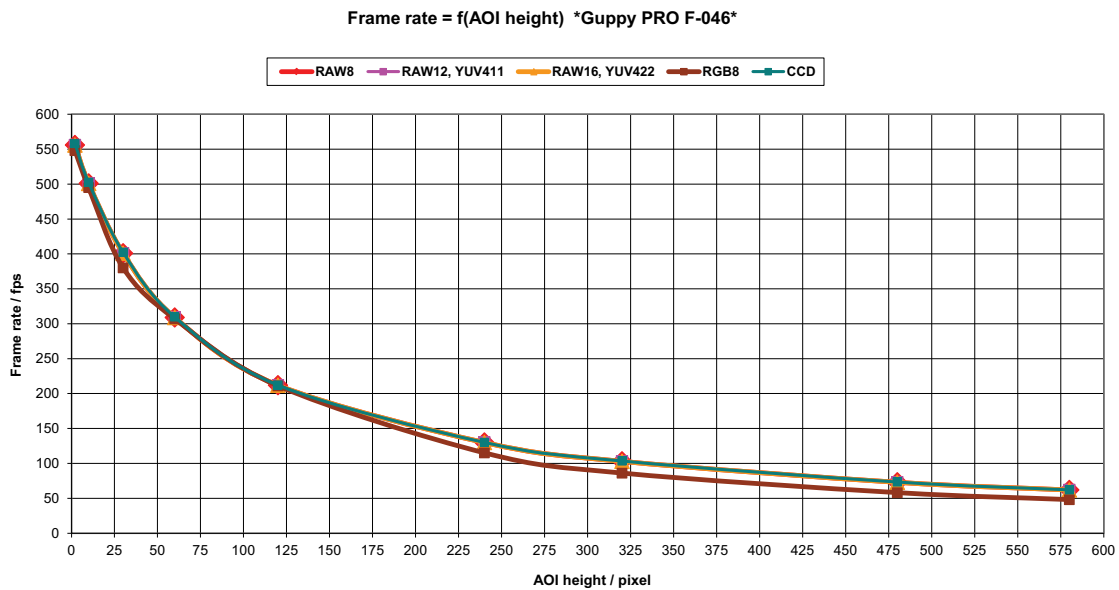

Figure 81: Frame rates **Guppy PRO F-046** as function of AOI height [width=780]

AOI height	CCD*	RAW8	RAW12	RAW16	YUV411	YUV422	RGB8
580	62.10	62	62	62	62	62	48
480	73.38	73	73	73	73	73	58
320	103.46	103	103	103	103	103	86
240	130.13	130	130	130	129	129	115
120	212.17	212	212	212	211	211	211
60	309.82	309	309	309	307	307	307
30	402.44	401	401	401	397	397	380
10	502.60	501	501	501	495	495	495
2	558.16	556	556	556	548	548	548

Table 93: Frame rates (fps) of **Guppy PRO F-046** as function of AOI height (pixel) [width=780]

* CCD = theoretical max. frame rate (in fps) of CCD according to given formula

Guppy PRO F-095: AOI frame rates

$$\text{max. frame rate of CCD} = \frac{1}{321.44\mu\text{s} + \text{AOI height} \times 35.04\mu\text{s} + (747 - \text{AOI height}) \times 6.88\mu\text{s}}$$

Formula 13: **Guppy PRO F-095**: theoretical max. frame rate of CCD

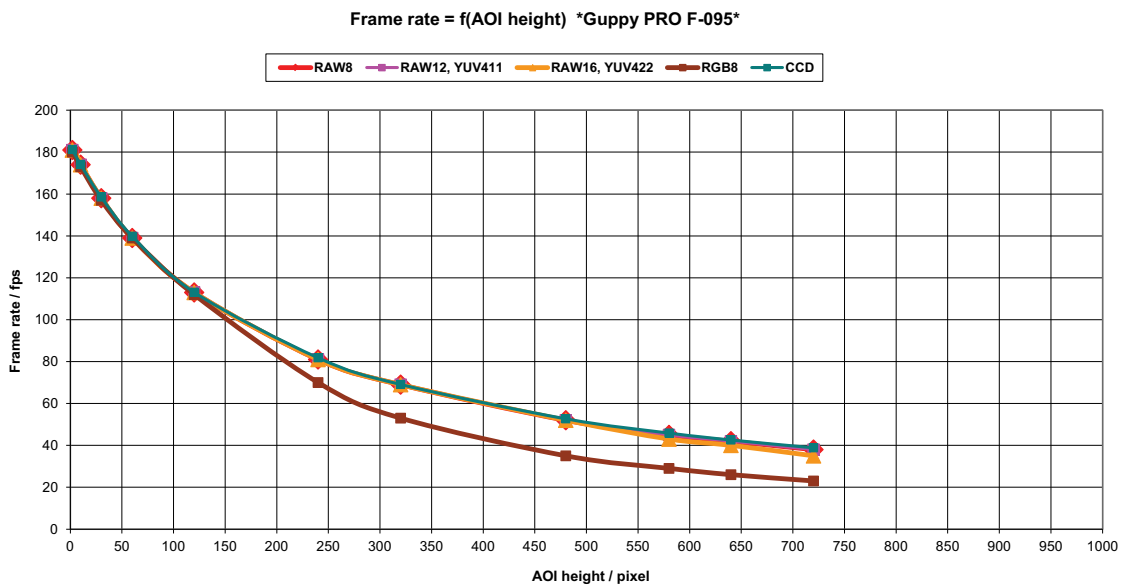

Figure 82: Frame rates **Guppy PRO F-095** as function of AOI height [width=1280]

AOI height	CCD*	RAW8	RAW12	RAW16	YUV411	YUV422	RGB8
720	38.85	38	38	35	38	35	23
640	42.58	42	42	40	42	39	26
580	45.88	45	45	43	45	43	29
480	52.69	52	52	52	52	52	35
320	69.09	69	69	69	68	68	53
240	81.83	81	81	81	81	81	70
120	113.12	113	113	113	112	112	112
60	139.85	139	139	139	139	139	139
30	158.58	158	158	158	158	157	157
10	174.14	174	174	174	173	173	173
2	181.25	181	181	181	180	180	180

Table 94: Frame rates (fps) of **Guppy PRO F-095** as function of AOI height (pixel) [width=1280]

* CCD = theoretical max. frame rate (in fps) of CCD according to given formula

Guppy PRO F-125: AOI frame rates

$$\text{max. frame rate of CCD} = \frac{1}{189.28\mu\text{s} + \text{AOI height} \times 33.19\mu\text{s} + (978 - \text{AOI height}) \times 5.03\mu\text{s}}$$

Formula 14: **Guppy PRO F-125**: theoretical max. frame rate of CCD

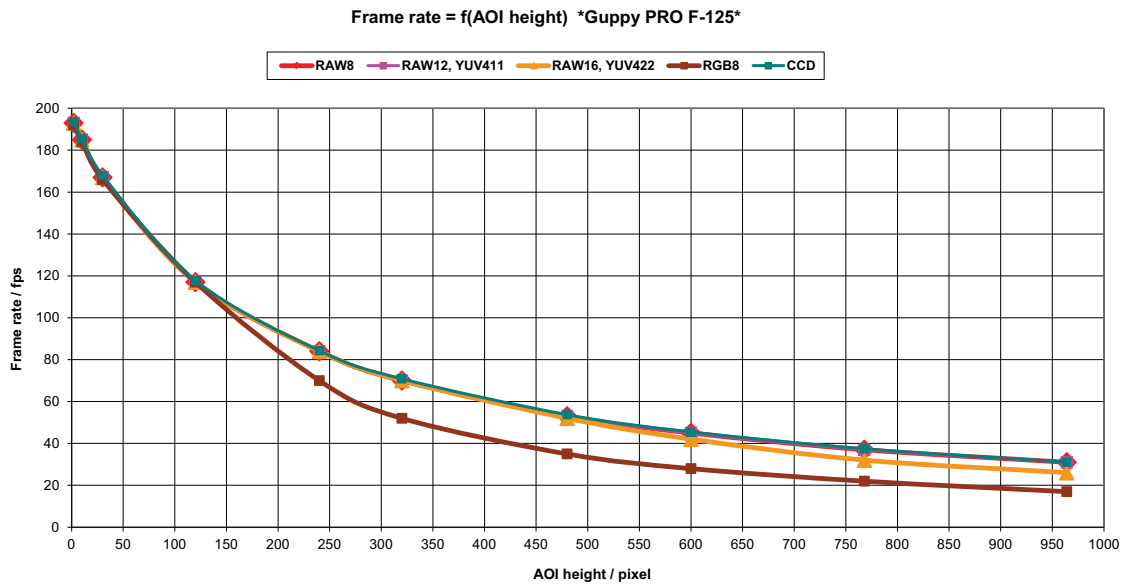

Figure 83: Frame rates **Guppy PRO F-125** as function of AOI height [width=1292]

AOI height	CCD*	RAW8	RAW12	RAW16	YUV411	YUV422	RGB8
964	31.00	31	31	26	31	26	17
768	37.40	37	37	32	37	32	22
600	45.45	45	45	42	45	42	28
480	53.69	53	53	52	53	52	35
320	70.82	70	70	70	70	70	52
240	84.27	84	84	84	84	84	70
120	117.82	117	117	117	117	117	117
30	167.97	167	167	167	166	166	166
10	185.52	185	185	185	184	184	184
2	193.61	193	193	193	192	192	192

Table 95: Frame rates (fps) **Guppy PRO F-125** as function of AOI height (pixel) [width=1292]

* CCD = theoretical max. frame rate (in fps) of CCD according to given formula (color modes: measured values)

Guppy PRO F-146: AOI frame rates

$$\text{max. frame rate of CCD} = \frac{1}{73.06\mu\text{s} + \text{AOI height} \times 56.07\mu\text{s} + (1051 - \text{AOI height}) \times 11.55\mu\text{s}}$$

Formula 15: **Guppy PRO F-146**: theoretical max. frame rate of CCD

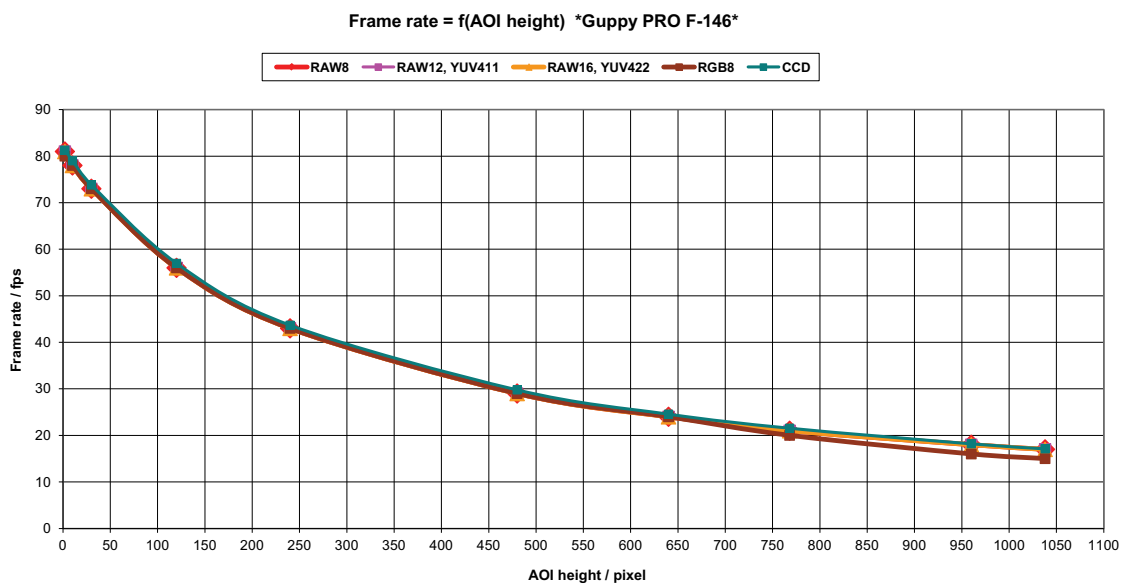

Figure 84: Frame rates **Guppy PRO F-146** as function of AOI height [width=1388]

AOI height	CCD*	RAW8	RAW12	RAW16	YUV411	YUV422	RGB8
1038	17.12	17	17	17	17	17	15
960	18.20	18	18	18	18	18	16
768	21.55	21	21	21	21	21	20
640	24.57	24	24	24	24	24	24
480	29.78	29	29	29	29	29	29
240	43.67	43	43	43	43	43	43
120	56.96	56	56	56	56	56	56
30	73.81	73	73	73	73	73	73
10	79.01	78	78	78	78	78	78
2	81.29	81	81	81	80	80	80

Table 96: Frame rates (fps) of **Guppy PRO F-146** as function of AOI height (pixel) [width=1388]

* CCD = theoretical max. frame rate (in fps) of CCD according to given formula (color modes: measured values)

Guppy PRO F-201: AOI frame rates

$$\text{max. frame rate of CCD} = \frac{1}{344.90\mu\text{s} + \text{AOI height} \times 57.50\mu\text{s} + (1238 - \text{AOI height}) \times 8.2\mu\text{s}}$$

Formula 16: Guppy PRO F-201: theoretical max. frame rate of CCD

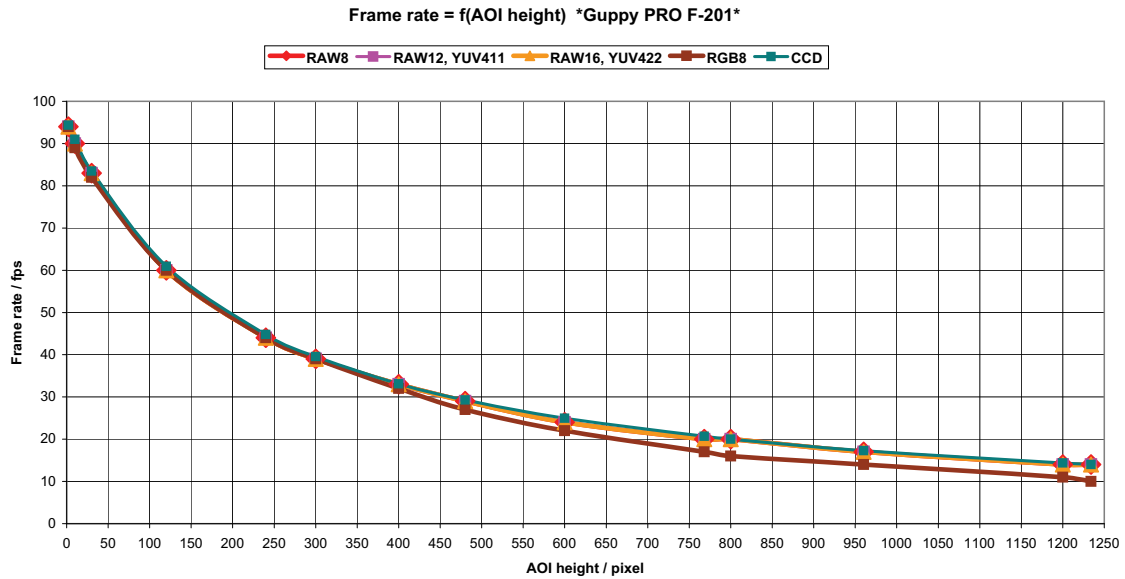

Formula 17: Frame rates Guppy PRO F-201 as function of AOI height [width=1624]

AOI height	CCD*	RAW8	RAW12	RAW16	YUV411	YUV422	RGB8
1234	14.02	14	14	14	14	14	12
1200	14.36	14	14	14	14	14	11
960	17.29	17	17	17	17	17	14
800	20.03	20	20	20	20	20	16
768	20.68	20	20	20	20	20	17
600	24.95	24	24	24	24	24	22
480	29.27	29	29	29	29	29	27
400	33.09	33	33	33	32	32	32
300	39.55	39	39	39	39	39	39
240	44.79	44	44	44	44	44	44
120	60.93	60	60	60	60	60	60
30	83.50	83	83	83	82	82	82
10	91.00	90	90	90	90	89	89
2	94.38	94	94	94	94	94	94

Table 97: Frame rates of Guppy PRO F-201 as function of AOI height [width=1624]

* CCD = theoretical max. frame rate (in fps) of CCD according to given formula (color modes: measured values)

Guppy PRO F-503: AOI frame rates

$$\text{max. frame rate of CMOS} = \frac{1}{(\text{AOI height} + 9) \times t_{\text{row}}}$$

Formula 18: **Guppy PRO F-503**: theoretical max. frame rate of CMOS (min. shutter, no binning, no sub-sampling). For calculating t_{row} , see Chapter [Exposure time of Guppy PRO F-503 \(CMOS\)](#) on page 153

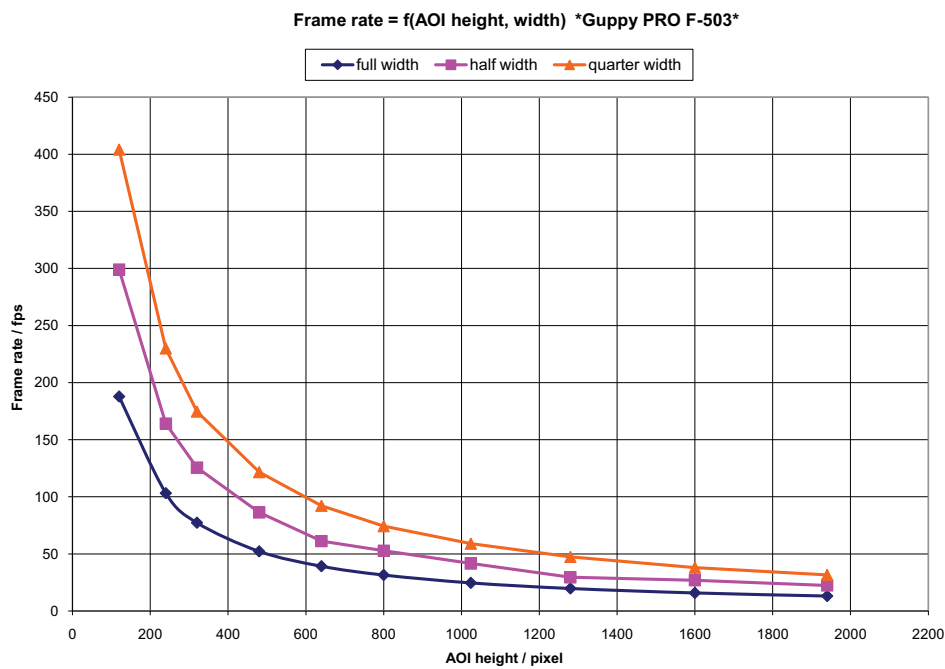

Figure 85: Frame rates Guppy PRO F-503 as function of AOI height and AOI width (full/half/quarter)

The frame rates in the following table are measured directly at the output of the camera (rolling shutter, Raw format). Compare with Chapter [How does bandwidth affect the frame rate?](#) on page 220.

AOI height / pixel	Frame rate / fps full width	Frame rate / fps half width	Frame rate / fps quarter width
1940	13.1	22.3	31.6
1600	15.8	26.9	38.0
1280	19.7	29.5	47.4
1024	24.6	41.6***	59.0

Table 98: Frame rates Guppy PRO F-503 as function of AOI height and AOI width (full/half/quarter)

AOI height / pixel	Frame rate / fps full width	Frame rate / fps half width	Frame rate / fps quarter width
800	31.5	52.8**	74.3
640	39.2	61.2	92.2
480	52.2	86.3	121.6
320	77.3	125.6	174.7
240	103.2	164.2	230.0
120	187.9*	299.1	404.2

Table 98: Frame rates Guppy PRO F-503 as function of AOI height and AOI width (full/half/quarter)

*: Max. packet size 7760

** : max. packet size 6980

***: max. packet size 6960

Note

The minimum AOI of GUPPY F-503 is 64 x 64 (AOI width x AOI height).



The readout time for one row is not constant. It varies with AOI width.

How does bandwidth affect the frame rate?

In some modes the IEEE 1394b bus limits the attainable frame rate. According to the 1394b specification on isochronous transfer, the largest data payload size of 8192 bytes per 125 μ s cycle is possible with bandwidth of 800 Mbit/s. In addition, there is a limitation, only a maximum number of 65535 ($2^{16} - 1$) packets per frame are allowed.

Note



Certain cameras may offer, depending on their settings in combination with the use of AVT FirePackage higher packet sizes.

Consult your local dealer's support team, if you require additional information on this feature.

The following formula establishes the relationship between the required Byte_Per_Packet size and certain variables for the image. It is valid only for Format_7.

$$\text{BYTE_PER_PACKET} = \text{frame rate} \times \text{AOI_WIDTH} \times \text{AOI_HEIGHT} \times \text{ByteDepth} \times 125\mu\text{s}$$

Formula 19: Byte_per_Packet calculation (only Format_7)

If the value for **BYTE_PER_PACKET** is greater than 8192 (the maximum data payload), the sought-after frame rate cannot be attained.

The attainable frame rate can be calculated using this formula:

(Provision: **BYTE_PER_PACKET** is divisible by 4):

$$\text{frame rate} \approx \frac{\text{BYTE_PER_PACKET}}{\text{AOI_WIDTH} \times \text{AOI_HEIGHT} \times \text{ByteDepth} \times 125\mu\text{s}}$$

Formula 20: Maximum frame rate calculation

ByteDepth is based on the following values:

Mode	bit/pixel	byte per pixel
Mono8, Raw8	8	1
Mono12, Raw12	12	1.5
Mono16, Raw16	14	2
YUV4:2:2	16	2
RGB8	24	3

Table 99: ByteDepth

Example formula for the b/w camera

Mono16, 1392 x 1040, 30 fps desired

$$\text{BYTE_PER_PACKET} = 30 \times 1392 \times 1040 \times 2 \times 125\mu\text{s} = 10856 > 8192$$

$$\Rightarrow \text{frame rate}_{\text{reachable}} \approx \frac{8192}{1392 \times 1040 \times 2 \times 125\mu\text{s}} = 22.64$$

Formula 21: Example maximum frame rate calculation

Test images

Loading test images

FirePackage	Fire4Linux
<ol style="list-style-type: none"> 1. Start SmartView. 2. Click the Edit settings button.  3. Click Adv1 tab. 4. In combo box Test images choose Image 1 or another test image. 	<ol style="list-style-type: none"> 1. Start cc1394 viewer. 2. In Adjustments menu click on Picture Control. 3. Click Main tab. 4. Activate Test image check box on. 5. In combo box Test images choose Image 1 or another test image.

Table 100: Loading test images in different viewers

Test images for b/w cameras

Guppy PRO b/w cameras have two test images that look the same. Both images show a grey bar running diagonally (mirrored at the middle axis).

- **Image 1** is static.
- **Image 2** moves upwards by 1 pixel/frame.



Figure 86: Grey bar test image

Test images for color cameras

The color cameras have 1 test image:

YUV4:2:2 mode



Figure 87: Color test image

Mono8 (raw data)

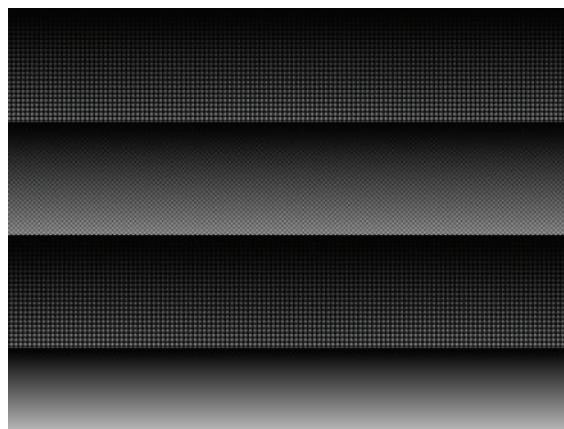

Figure 88: Bayer-coded test image

The color camera outputs Bayer-coded raw data in Mono8 instead of (as described in IIDC V1.31) a real Y signal.

Note The first pixel of the image is always the **red** pixel from the sensor. (Mirror must be switched off.)



Configuration of the camera

All camera settings are made by writing specific values into the corresponding registers.

This applies to:

- values for general operating states such as video formats and modes, exposure times, etc.
- extended features of the camera that are turned on and off and controlled via corresponding registers (so-called advanced registers).

Camera_Status_Register

The interoperability of cameras from different manufacturers is ensured by IIDC, formerly DCAM (Digital Camera Specification), published by the IEEE 1394 Trade Association.

IIDC is primarily concerned with setting memory addresses (e.g. CSR: Camera_Status_Register) and their meaning.

In principle all addresses in IEEE 1394 networks are 64 bits long.

The first 10 bits describe the Bus_Id, the next 6 bits the Node_Id.

Of the subsequent 48 bit, the first 16 bit are always FFFFh, leaving the description for the Camera_Status_Register in the last 32 bit.

If a CSR F0F00600h is mentioned below this means in full:

Bus_Id, Node_Id, FFFF F0F00600h

Writing and reading to and from the register can be done with programs such as **FireView** or by other programs developed using an API library (e.g. **FirePackage**).¹⁰ Every register is 32 bit (big endian) and implemented as follows (MSB = Most Significant Bit; LSB = Least Significant Bit):

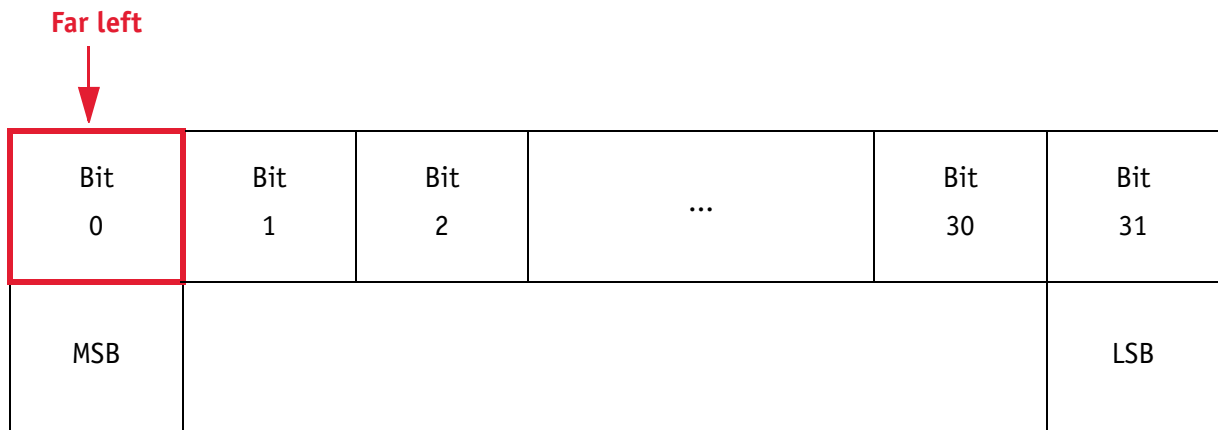

Table 101: 32-bit register

Example

This requires, for example, that to enable **ISO_Enabled mode** (see Chapter [ISO_Enabled / free-run](#) on page 159), (bit 0 in register 614h), the value 80000000 h must be written in the corresponding register.

Register: ISO_ENABLE

Address: F0F00614

Data: 80000000

Offset of Register: (0x0F00614) ISO_Enable

Write 80000000 and click **Write**

#	rw	Address	Value
2	wr	F0F00614	80000000
1	rd	F0F00614	00000000

Content of register: 80000000
 = 1000 0000 0000 0000 0000 0000 0000 0000

Figure 89: Enabling ISO_Enabled

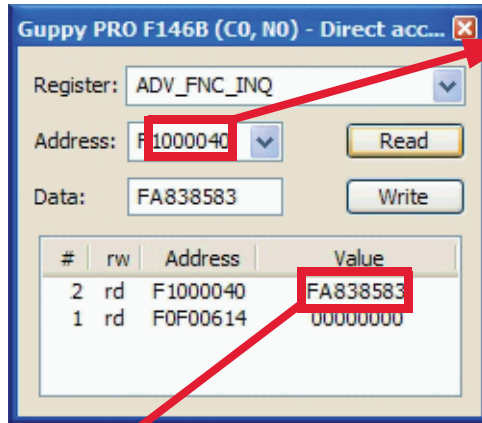

Offset of Register: (0xF1000040)
ADV_FNC_INQ

Content of register: FA838583
= 1111 1010 1000 0011 1000 0101 1000 0011

Table 102: Configuring the camera (Guppy PRO F-146B)

	MaxResolution	TimeBase	ExtdShutter	Testimage		VersionInfo		Look-up tables						Trigger Delay	Misc. features	
Bit	0	1	2	3	4	5	6	7	8	9	10	11	12	13	14	15
	1	1	1	1	1	0	1	0	1	0	0	0	0	0	1	1

	SoftReset				UserProfiles										GP_Buffer	
Bit	16	17	18	19	20	21	22	23	24	25	26	27	28	29	30	31
	1	0	0	0	0	1	0	1	1	0	0	0	0	0	1	1

Table 103: Configuring the camera: registers

Sample program

The following sample code in C/C++ shows how the register is set for video mode/format, trigger mode etc. using the **FireGrab** and **FireStack API**.

Example FireGrab

```
...
// Set Videoformat
if(Result==FCE_NOERROR)
    Result= Camera.SetParameter(FGP_IMAGEFORMAT, MAKEIMAGEFORMAT(RES_640_480,
CM_Y8, FR_15));

// Set external Trigger
if(Result==FCE_NOERROR)
    Result= Camera.SetParameter(FGP_TRIGGER, MAKETRIGGER(1, 0, 0, 0, 0));

// Start DMA logic
if(Result==FCE_NOERROR)
    Result=Camera.OpenCapture();

// Start image device
if(Result==FCE_NOERROR)
    Result=Camera.StartDevice();

...
```

Example FireStack API

```
...
// Set framerate

Result=WriteQuad(HIGHOFFSET,m_Props.CmdRegBase+CCR_FRAMERATE, (UINT32)m_Parms.F
rameRate<<29);

    // Set mode
    if(Result)

Result=WriteQuad(HIGHOFFSET,m_Props.CmdRegBase+CCR_VMODE, (UINT32)m_Parms.Video
Mode<<29);

    // Set format
    if(Result)

Result=WriteQuad(HIGHOFFSET,m_Props.CmdRegBase+CCR_VFORMAT, (UINT32)m_Parms.Vid
eoFormat<<29);

    // Set trigger
    if(Result)
    {
        Mode=0;
        if(m_Parms.TriggerMode==TM_EXTERN)
            Mode=0x82000000;
        if(m_Parms.TriggerMode==TM_MODE15)
            Mode=0x820F0000;
        WriteQuad(HIGHOFFSET,m_Props.CmdRegBase+CCR_TRGMODE, Mode);
    }

    // Start continuous ISO if not oneshot triggermode
    if(Result && m_Parms.TriggerMode!=TM_ONESHOT)
        Result=WriteQuad(HIGHOFFSET,m_Props.CmdRegBase+CCR_ISOENABLE, 0x80000000);

...
```

Configuration ROM

The information in the **configuration ROM** is needed to identify the node, its capabilities and which drivers are required.

The base address for the **configuration ROM** for all registers is FFFF F000000h.

Note If you want to use the **DirectControl** program to read or write to a register, enter the following value in the Address field:



F0F00000h + Offset

The **configuration ROM** is divided into

- Bus info block: providing critical information about the bus-related capabilities
- Root directory: specifying the rest of the content and organization, such as:
 - Node unique ID leaf
 - Unit directory
 - Unit dependant info

The base address of the camera control register is calculated as follows based on the camera-specific base address:

	Offset	0-7	8-15	16-23	24-31	
Bus info block	400h	04	29	0C	C0	
	404h	31	33	39	34 ASCII for 1394
	408h	20	00	B2	03 Bus capabilities
	40Ch	00	0A	47	01 <i>Node_Vendor_Id</i> , <i>Chip_id_hi</i>
	410h	Serial number			 <i>Chip_id_lo</i>
Root directory	414h	00	04	B7	85	According to IEEE1212, the root directory may have another length. The keys (e.g. 8D) point to the offset factors rather than the offset (e.g. 420h) itself.
	418h	03	00	0A	47	
	41Ch	0C	00	83	C0	
	420h	8D	00	00	02	
	424h	D1	00	00	04	

Table 104: Configuration ROM

The entry with key 8D in the root directory (420h in this case) provides the offset for the Node unique ID leaf.

To compute the effective start address of the node unique ID leaf:

To compute the effective start address of the node unique ID leaf	
currAddr	= node unique ID leaf address
destAddr	= address of directory entry
addrOffset	= value of directory entry
destAddr	= currAddr + (4 x addrOffset)
	= 420h + (4 x 000002h)
	= 428h

Table 105: Computing effective start address

$$420h + 000002h \times 4 = 428h$$

	Offset	0-7	8-15	16-23	24-31	
→	428h	00	02	5E	9ECRC
Node unique ID leaf	42Ch	00	0A	47	01Node_Vendor_Id,Chip_id_hi
	430h	00	00	Serial number		

Table 106: Configuration ROM

The entry with key D1 in the root directory (424h in this case) provides the offset for the unit directory as follows:

$$424h + 000004 \times 4 = 434h$$

	Offset	0-7	8-15	16-23	24-31
→	434h	00	03	93	7D
Unit directory	438h	12	00	A0	2D
	43Ch	13	00	01	02
	440h	D4	00	00	01

Table 107: Configuration ROM

The entry with key D4 in the unit directory (440h in this case) provides the offset for unit dependent info:

$$440h + 0000xx \times 4 = 444h$$

	Offset	0-7	8-15	16-23	24-31	
→ Unit dependent info	444h	00	0B	A9	6Eunit_dep_info_length, CRC
	448h	40	3C	00	00command_regs_base
	44Ch	81	00	00	02vender_name_leaf
	450h	82	00	00	06model_name_leaf
	454h	38	00	00	10unit_sub_sw_version
	458h	39	00	00	00Reserved
	45Ch	3A	00	00	00Reserved
	460h	3B	00	00	00Reserved
	464h	3C	00	01	00vendor_unique_info_0
	468h	3D	00	92	00vendor_unique_info_1
	46Ch	3E	00	00	65vendor_unique_info_2
	470h	3F	00	00	00vendor_unique_info_3

Table 108: Configuration ROM

And finally, the entry with key 40 (448h in this case) provides the offset for the camera control register:

$$\text{FFFF F0000000h} + 3\text{C0000h} \times 4 = \text{FFFF F0F00000h}$$

The base address of the camera control register is thus:

$$\text{FFFF F0F00000h}$$

The offset entered in the table always refers to the base address of F0F00000h.

Implemented registers (IIDC V1.31)

The following tables show how standard registers from IIDC V1.31 are implemented in the camera:

- Base address is F0F00000h
- Differences and explanations can be found in the **Description** column.

Camera initialize register

Offset	Name	Description
000h	INITIALIZE	Assert MSB = 1 for Init.

Table 109: Camera initialize register

Inquiry register for video format

Offset	Name	Field	Bit	Description
100h	V_FORMAT_INQ	Format_0	[0]	Up to VGA (non compressed)
		Format_1	[1]	SVGA to XGA
		Format_2	[2]	SXGA to UXGA
		Format_3	[3..5]	Reserved
		Format_6	[6]	Still Image Format
		Format_7	[7]	Partial Image Format
		---	[8..31]	Reserved

Table 110: Format inquiry register

Inquiry register for video mode

Offset	Name	Field	Bit	Description	Color mode
180h	V_MODE_INQ (Format_0)	Mode_0	[0]	160 x 120	YUV 4:4:4
		Mode_1	[1]	320 x 240	YUV 4:2:2
		Mode_2	[2]	640 x 480	YUV 4:1:1
		Mode_3	[3]	640 x 480	YUV 4:2:2
		Mode_4	[4]	640 x 480	RGB
		Mode_5	[5]	640 x 480	MON08
		Mode_6	[6]	640 x 480	MON016
		Mode_X	[7]	Reserved	
		---	[8..31]	Reserved (zero)	
184h	V_MODE_INQ (Format_1)	Mode_0	[0]	800 x 600	YUV 4:2:2
		Mode_1	[1]	800 x 600	RGB
		Mode_2	[2]	800 x 600	MON08
		Mode_3	[3]	1024 x 768	YUV 4:2:2
		Mode_4	[4]	1024 x 768	RGB
		Mode_5	[5]	1024 x 768	MON08
		Mode_6	[6]	800 x 600	MON016
		Mode_7	[7]	1024 x 768	MON016
		---	[8..31]	Reserved (zero)	
188h	V_MODE_INQ (Format_2)	Mode_0	[0]	1280 x 960	YUV 4:2:2
		Mode_1	[1]	1280 x 960	RGB
		Mode_2	[2]	1280 x 960	MON08
		Mode_3	[3]	1600 x 1200	YUV 4:2:2
		Mode_4	[4]	1600 x 1200	RGB
		Mode_5	[5]	1600 x 1200	MON08
		Mode_6	[6]	1280 x 960	MON016
		Mode_7	[7]	1600 x 1200	MON016
		---	[8..31]	Reserved (zero)	
18Ch ... 197h	Reserved for other V_MODE_INQ_x for Format_x.			Always 0	
198h	V_MODE_INQ_6 (Format_6)			Always 0	

Table 111: **Video mode** inquiry register

Offset	Name	Field	Bit	Description	Color mode
19Ch	V_MODE_INQ (Format_7)	Mode_0	[0]	Format_7 Mode_0	
		Mode_1	[1]	Format_7 Mode_1	
		Mode_2	[2]	Format_7 Mode_2	
		Mode_3	[3]	Format_7 Mode_3	
		Mode_4	[4]	Format_7 Mode_4	
		Mode_5	[5]	Format_7 Mode_5	
		Mode_6	[6]	Format_7 Mode_6	
		Mode_7	[7]	Format_7 Mode_7	
		---	[8..31]	Reserved (zero)	

Table 111: Video mode inquiry register

Inquiry register for video frame rate and base address

Offset	Name	Field	Bit	Description
200h	V_RATE_INQ (Format_0, Mode_0)	FrameRate_0	[0]	Reserved
		FrameRate_1	[1]	Reserved
		FrameRate_2	[2]	7.5 fps
		FrameRate_3	[3]	15 fps
		FrameRate_4	[4]	30 fps
		FrameRate_5	[5]	60 fps
		FrameRate_6	[6]	120 fps (V1.31)
		FrameRate_7	[7]	240 fps (V1.31)
		---	[8..31]	Reserved (zero)
204h	V_RATE_INQ (Format_0, Mode_1)	FrameRate_0	[0]	1.875 fps
		FrameRate_1	[1]	3.75 fps
		FrameRate_2	[2]	7.5 fps
		FrameRate_3	[3]	15 fps
		FrameRate_4	[4]	30 fps
		FrameRate_5	[5]	60 fps
		FrameRate_6	[6]	120 fps (V1.31)
		FrameRate_7	[7]	240 fps (V1.31)
		---	[8..31]	Reserved (zero)

Table 112: Frame rate inquiry register

Offset	Name	Field	Bit	Description
208h	V_RATE_INQ (Format_0, Mode_2)	FrameRate_0	[0]	1.875 fps
		FrameRate_1	[1]	3.75 fps
		FrameRate_2	[2]	7.5 fps
		FrameRate_3	[3]	15 fps
		FrameRate_4	[4]	30 fps
		FrameRate_5	[5]	60 fps
		FrameRate_6	[6]	120 fps (V1.31)
		FrameRate_7	[7]	240 fps (V1.31)
		---	[8..31]	Reserved (zero)
20Ch	V_RATE_INQ (Format_0, Mode_3)	FrameRate_0	[0]	1.875 fps
		FrameRate_1	[1]	3.75 fps
		FrameRate_2	[2]	7.5 fps
		FrameRate_3	[3]	15 fps
		FrameRate_4	[4]	30 fps
		FrameRate_5	[5]	60 fps
		FrameRate_6	[6]	120 fps (V1.31)
		FrameRate_7	[7]	240 fps (V1.31)
		---	[8..31]	Reserved (zero)
210h	V_RATE_INQ (Format_0, Mode_4)	FrameRate_0	[0]	1.875 fps
		FrameRate_1	[1]	3.75 fps
		FrameRate_2	[2]	7.5 fps
		FrameRate_3	[3]	15 fps
		FrameRate_4	[4]	30 fps
		FrameRate_5	[5]	60 fps
		FrameRate_6	[6]	120 fps (V1.31)
		FrameRate_7	[7]	240 fps (V1.31)
		---	[8..31]	Reserved (zero)

Table 112: **Frame rate** inquiry register

Offset	Name	Field	Bit	Description
214h	V_RATE_INQ (Format_0, Mode_5)	FrameRate_0	[0]	1.875 fps
		FrameRate_1	[1]	3.75 fps
		FrameRate_2	[2]	7.5 fps
		FrameRate_3	[3]	15 fps
		FrameRate_4	[4]	30 fps
		FrameRate_5	[5]	60 fps
		FrameRate_6	[6]	120 fps (V1.31)
		FrameRate_7	[7]	240 fps (V1.31)
		---	[8..31]	Reserved (zero)
218h	V_RATE_INQ	(Format_0, Mode_6) FrameRate_0	[0]	1.875 fps
		FrameRate_1	[1]	3.75 fps
		FrameRate_2	[2]	7.5 fps
		FrameRate_3	[3]	15 fps
		FrameRate_4	[4]	30 fps
		FrameRate_5	[5]	60 fps
		FrameRate_6	[6]	120 fps (V1.31)
		FrameRate_7	[7]	240 fps (V1.31)
		---	[8..31]	Reserved (zero)
21Ch ... 21Fh	Reserved V_RATE_INQ_0_x (for other Mode_x of Format_0)			Always 0
220h	V_RATE_INQ (Format_1, Mode_0)	FrameRate_0	[0]	Reserved
		FrameRate_1	[1]	3.75 fps
		FrameRate_2	[2]	7.5 fps
		FrameRate_3	[3]	15 fps
		FrameRate_4	[4]	30 fps
		FrameRate_5	[5]	60 fps
		FrameRate_6	[6]	120 fps (V1.31)
		FrameRate_7	[7]	240 fps (V1.31)
		---	[8..31]	Reserved (zero)

Table 112: **Frame rate** inquiry register

Offset	Name	Field	Bit	Description
224h	V_RATE_INQ (Format_1, Mode_1)	FrameRate_0	[0]	Reserved
		FrameRate_1	[1]	Reserved
		FrameRate_2	[2]	7.5 fps
		FrameRate_3	[3]	15 fps
		FrameRate_4	[4]	30 fps
		FrameRate_5	[5]	60 fps
		FrameRate_6	[6]	120 fps (V1.31)
		FrameRate_7	[7]	240 fps (V1.31)
		---	[8..31]	Reserved (zero)
228h	V_RATE_INQ (Format_1, Mode_2)	FrameRate_0	[0]	Reserved
		FrameRate_1	[1]	Reserved
		FrameRate_2	[2]	7.5 fps
		FrameRate_3	[3]	15 fps
		FrameRate_4	[4]	30 fps
		FrameRate_5	[5]	60 fps
		FrameRate_6	[6]	120 fps (V1.31)
		FrameRate_7	[7]	240 fps (V1.31)
		---	[8..31]	Reserved (zero)
22Ch	V_RATE_INQ (Format_1, Mode_3)	FrameRate_0	[0]	1.875 fps
		FrameRate_1	[1]	3.75 fps
		FrameRate_2	[2]	7.5 fps
		FrameRate_3	[3]	15 fps
		FrameRate_4	[4]	30 fps
		FrameRate_5	[5]	60 fps
		FrameRate_6	[6]	120 fps (V1.31)
		FrameRate_7	[7]	240 fps (V1.31)
		---	[8..31]	Reserved (zero)

Table 112: **Frame rate** inquiry register

Offset	Name	Field	Bit	Description
230h	V_RATE_INQ (Format_1, Mode_4)	FrameRate_0	[0]	1.875 fps
		FrameRate_1	[1]	3.75 fps
		FrameRate_2	[2]	7.5 fps
		FrameRate_3	[3]	15 fps
		FrameRate_4	[4]	30 fps
		FrameRate_5	[5]	60 fps
		FrameRate_6	[6]	120 fps (V1.31)
		FrameRate_7	[7]	240 fps (V1.31)
		---	[8..31]	Reserved (zero)
234h	V_RATE_INQ (Format_1, Mode_5)	FrameRate_0	[0]	1.875 fps
		FrameRate_1	[1]	3.75 fps
		FrameRate_2	[2]	7.5 fps
		FrameRate_3	[3]	15 fps
		FrameRate_4	[4]	30 fps
		FrameRate_5	[5]	60 fps
		FrameRate_6	[6]	120 fps (V1.31)
		FrameRate_7	[7]	240 fps (V1.31)
		---	[8..31]	Reserved (zero)
238h	V_RATE_INQ (Format_1, Mode_6)	FrameRate_0	[0]	1.875 fps
		FrameRate_1	[1]	3.75 fps
		FrameRate_2	[2]	7.5 fps
		FrameRate_3	[3]	15 fps
		FrameRate_4	[4]	30 fps
		FrameRate_5	[5]	60 fps
		FrameRate_6	[6]	120 fps (V1.31)
		FrameRate_7	[7]	240 fps (V1.31)
		---	[8..31]	Reserved (zero)

Table 112: **Frame rate** inquiry register

Offset	Name	Field	Bit	Description
23Ch	V_RATE_INQ (Format_1, Mode_7)	FrameRate_0	[0]	1.875 fps
		FrameRate_1	[1]	3.75 fps
		FrameRate_2	[2]	7.5 fps
		FrameRate_3	[3]	15 fps
		FrameRate_4	[4]	30 fps
		FrameRate_5	[5]	60 fps
		FrameRate_6	[6]	120 fps (V1.31)
		FrameRate_7	[7]	Reserved
		---	[8..31]	Reserved (zero)
240h	V_RATE_INQ (Format_2, Mode_0)	FrameRate_0	[0]	1.875 fps
		FrameRate_1	[1]	3.75 fps
		FrameRate_2	[2]	7.5 fps
		FrameRate_3	[3]	15 fps
		FrameRate_4	[4]	30 fps
		FrameRate_5	[5]	60 fps
		FrameRate_6	[6]	Reserved
		FrameRate_7	[7]	Reserved
		---	[8..31]	Reserved (zero)
244h	V_RATE_INQ (Format_2, Mode_1)	FrameRate_0	[0]	1.875 fps
		FrameRate_1	[1]	3.75 fps
		FrameRate_2	[2]	7.5 fps
		FrameRate_3	[3]	15 fps
		FrameRate_4	[4]	30 fps
		FrameRate_5	[5]	60 fps
		FrameRate_6	[6]	Reserved
		FrameRate_7	[7]	Reserved
		---	[8..31]	Reserved (zero)

Table 112: **Frame rate** inquiry register

Offset	Name	Field	Bit	Description
248h	V_RATE_INQ (Format_2, Mode_2)	FrameRate_0	[0]	1.875 fps
		FrameRate_1	[1]	3.75 fps
		FrameRate_2	[2]	7.5 fps
		FrameRate_3	[3]	15 fps
		FrameRate_4	[4]	30 fps
		FrameRate_5	[5]	60 fps
		FrameRate_6	[6]	120 fps (V1.31)
		FrameRate_7	[7]	Reserved
		---	[8..31]	Reserved (zero)
24Ch	V_RATE_INQ (Format_2, Mode_3)	FrameRate_0	[0]	1.875 fps
		FrameRate_1	[1]	3.75 fps
		FrameRate_2	[2]	7.5 fps
		FrameRate_3	[3]	15 fps
		FrameRate_4	[4]	30 fps
		FrameRate_5	[5]	60 fps
		FrameRate_6	[6]	Reserved
		FrameRate_7	[7]	Reserved
		---	[8..31]	Reserved (zero)
250h	V_RATE_INQ (Format_2, Mode_4)	FrameRate_0	[0]	1.875 fps
		FrameRate_1	[1]	3.75 fps
		FrameRate_2	[2]	7.5 fps
		FrameRate_3	[3]	15 fps
		FrameRate_4	[4]	30 fps
		FrameRate_5	[5]	Reserved
		FrameRate_6	[6]	Reserved
		FrameRate_7	[7]	Reserved
		---	[8..31]	Reserved (zero)

Table 112: **Frame rate** inquiry register

Offset	Name	Field	Bit	Description
254h	V_RATE_INQ (Format_2, Mode_5)	FrameRate_0	[0]	1.875 fps
		FrameRate_1	[1]	3.75 fps
		FrameRate_2	[2]	7.5 fps
		FrameRate_3	[3]	15 fps
		FrameRate_4	[4]	30 fps
		FrameRate_5	[5]	60 fps
		FrameRate_6	[6]	Reserved
		FrameRate_7	[7]	Reserved
		---	[8..31]	Reserved (zero)
258h	V_RATE_INQ (Format_2, Mode_6)	FrameRate_0	[0]	1.875 fps
		FrameRate_1	[1]	3.75 fps
		FrameRate_2	[2]	7.5 fps
		FrameRate_3	[3]	15 fps
		FrameRate_4	[4]	30 fps
		FrameRate_5	[5]	60 fps
		FrameRate_6	[6]	Reserved
		FrameRate_7	[7]	Reserved
		---	[8..31]	Reserved (zero)
25Ch	V_RATE_INQ (Format_2, Mode_7)	FrameRate_0	[0]	1.875 fps
		FrameRate_1	[1]	3.75 fps
		FrameRate_2	[2]	7.5 fps
		FrameRate_3	[3]	15 fps
		FrameRate_4	[4]	30 fps
		FrameRate_5	[5]	60 fps
		FrameRate_6	[6]	Reserved
		FrameRate_7	[7]	Reserved
		---	[8..31]	Reserved
260h ... 2BFh	Reserved V_RATE_INQ_y_x (for other Format_y, Mode_x)			
2C0h	V_REV_INQ_6_0 (Format_6, Mode0)			Always 0
2C4h .. 2DFh	Reserved V_REV_INQ_6_x (for other Mode_x of Format_6)			Always 0

Table 112: **Frame rate** inquiry register

Offset	Name	Field	Bit	Description
2E0h		V-CSR_INQ_7_0	[0..31]	CSR_quadlet offset for Format_7 Mode_0
2E4h		V-CSR_INQ_7_1	[0..31]	CSR_quadlet offset for Format_7 Mode_1
2E8h		V-CSR_INQ_7_2	[0..31]	CSR_quadlet offset for Format_7 Mode_2
2ECh		V-CSR_INQ_7_3	[0..31]	CSR_quadlet offset for Format_7 Mode_3
2F0h		V-CSR_INQ_7_4	[0..31]	CSR_quadlet offset for Format_7 Mode_4
2F4h		V-CSR_INQ_7_5	[0..31]	CSR_quadlet offset for Format_7 Mode_5
2F8h		V-CSR_INQ_7_6	[0..31]	CSR_quadlet offset for Format_7 Mode_6
2FCh		V-CSR_INQ_7_7	[0..31]	CSR_quadlet offset for Format_7 Mode_7

Table 112: **Frame rate** inquiry register

Inquiry register for basic function

Offset	Name	Field	Bit	Description
400h	BASIC_FUNC_INQ	Advanced_Feature_Inq	[0]	Inquiry for advanced features (Vendor unique Features)
		Vmode_Error_Status_Inq	[1]	Inquiry for existence of Vmode_Error_Status register
		Feature_Control_Error_Status_Inq	[2]	Inquiry for existence of Feature_Control_Error_Status
		Opt_Func_CSR_Inq	[3]	Inquiry for Opt_Func_CSR
		---	[4..7]	Reserved
		1394b_mode_Capability	[8]	Inquiry for 1394b_mode_Capability
		---	[9..15]	Reserved
		Cam_Power_Cntl	[16]	Camera process power ON/OFF capability
		---	[17..18]	Reserved
		One_Shot_Inq	[19]	One-shot transmission capability
		Multi_Shot_Inq	[20]	Multi-shot transmission capability
		---	[21..27]	Reserved
		Memory_Channel	[28..31]	Maximum memory channel number (N) If 0000, no user memory available

Table 113: **Basic function** inquiry register

Inquiry register for feature presence

Offset	Name	Field	Bit	Description
404h	FEATURE_HI_INQ	Brightness	[0]	Brightness control
		Auto_Exposure	[1]	Auto_Exposure control
		---	[2]	Reserved
		White_Balance	[3]	White balance control
		Hue	[4]	Hue control
		Saturation	[5]	Saturation control
		Gamma	[6]	Gamma control
		Shutter	[7]	Shutter control
		Gain	[8]	Gain control
		Iris	[9]	Iris control
		Focus	[10]	Focus control
		Temperature	[11]	Temperature control
		Trigger	[12]	Trigger control
		Trigger_Delay	[13]	Trigger_Delay control
		---	[14]	Reserved
408h	FEATURE_LO_INQ	Zoom	[0]	Zoom control
		Pan	[1]	Pan control
		Tilt	[2]	Tilt control
		Optical_Filter	[3]	Optical_Filter control
		---	[4..15]	Reserved
		Capture_Size	[16]	Capture_Size for Format_6
		Capture_Quality	[17]	Capture_Quality for Format_6
		---	[16..31]	Reserved
40Ch	OPT_FUNCTION_INQ	---	[0]	Reserved
		PIO	[1]	Parallel Input/Output control
		SIO	[2]	Serial Input/Output control
		Strobe_out	[4..31]	Strobe signal output

Table 114: **Feature presence** inquiry register

Offset	Name	Field	Bit	Description
410h .. 47Fh	Reserved			Address error on access
480h	Advanced_Feature_Inq	Advanced_Feature_Quadlet_Offset	[0..31]	<p>Quadlet offset of the advanced feature CSR's from the base address of initial register space (vendor unique)</p> <p>This register is the offset for the Access_Control_Register and thus the base address for Advanced Features.</p> <p>Access_Control_Register does not prevent access to advanced features. In some programs it should still always be activated first.</p> <p>Advanced Feature Set Unique Value is 7ACh and CompanyID is A47h.</p>
484h	PIO_Control_CSR_Inq	PIO_Control_Quadlet_Offset	[0..31]	Quadlet offset of the PIO_Control CSR's from the base address of initial register space (Vendor unique)
488h	SIO_Control_CSR_Inq	SIO_Control_Quadlet_Offset	[0..31]	Quadlet offset of the SIO_Control CSR's from the base address of initial register space (vendor unique)
48Ch	Strobe_Output_CSR_Inq	Strobe_Output_Quadlet_Offset	[0..31]	Quadlet offset of the Strobe_Output signal CSR's from the base address of initial register space (vendor unique)

Table 114: **Feature presence** inquiry register

Inquiry register for feature elements

Register	Name	Field	Bit	Description
0xF0F00500	BRIGHTNESS_INQUIRY	Presence_Inq	[0]	Indicates presence of this feature (read only)
		Abs_Control_Inq	[1]	Capability of control with absolute value
		---	[2]	Reserved
		One_Push_Inq	[3]	One-push auto mode (controlled automatically by the camera once)
		Readout_Inq	[4]	Capability of reading out the value of this feature
		ON_OFF	[5]	Capability of switching this feature ON and OFF
		Auto_Inq	[6]	Auto Mode (Controlled automatically by the camera)
		Manual_Inq	[7]	Manual Mode (Controlled by user)
		Min_Value	[8..19]	Minimum value for this feature
		Max_Value	[20..31]	Maximum value for this feature
504h	AUTO_EXPOSURE_INQ	Same definition as Brightness_inq.		
508h	SHARPNESS_INQ	Same definition as Brightness_inq.		
50Ch	WHITE_BAL_INQ	Same definition as Brightness_inq.		
510h	HUE_INQ	Same definition as Brightness_inq.		
514h	SATURATION_INQ	Same definition as Brightness_inq.		
518h	GAMMA_INQ	Same definition as Brightness_inq.		
51Ch	SHUTTER_INQ	Same definition as Brightness_inq.		
520h	GAIN_INQ	Same definition as Brightness_inq.		
524h	IRIS_INQ	Always 0		
528h	FOCUS_INQ	Always 0		
52Ch	TEMPERATURE_INQ	Same definition as Brightness_inq.		

Table 115: **Feature elements** inquiry register

Register	Name	Field	Bit	Description
530h	TRIGGER_INQ	Presence_Inq	[0]	Indicates presence of this feature (read only)
		Abs_Control_Inq	[1]	Capability of control with absolute value
		---	[2..3]	Reserved
		Readout_Inq	[4]	Capability of reading out the value of this feature
		ON_OFF	[5]	Capability of switching this feature ON and OFF
		Polarity_Inq	[6]	Capability of changing the polarity of the trigger input
		Value_Read_Inq	[7]	Capability of reading raw trigger input Here you can read if trigger is active. In case of external trigger, you can read a combined signal.
		Trigger_Source0_Inq	[8]	Presence of Trigger Source 0 ID=0 Indicates usage of standard inputs.
---	[9..31]	Reserved		

Table 115: **Feature elements** inquiry register

Register	Name	Field	Bit	Description
534h	TRIGGER_DELAY_INQUIRY	Presence_Inq	[0]	Indicates presence of this feature (read only)
		Abs_Control_Inq	[1]	Capability of control with absolute value
		---	[2]	Reserved
		One_Push_Inq	[3]	One Push auto mode Controlled automatically by the camera once)
		Readout_Inq	[4]	Capability of reading out the value of this feature
		ON_OFF	[5]	Capability of switching this feature ON and OFF
		Auto_Inq	[6]	Auto Mode (Controlled automatically by the camera)
		Manual_Inq	[7]	Manual Mode (Controlled by user)
		Min_Value	[8..19]	Minimum value for this feature
		Max_Value	[20..31]	Maximum value for this feature
538 .. 57Ch	Reserved for other FEATURE_HI_INQ			
580h	ZOOM_INQ	Always 0		
584h	PAN_INQ	Always 0		
588h	TILT_INQ	Always 0		
58Ch	OPTICAL_FILTER_INQ	Always 0		
590 .. 5BCh	Reserved for other FEATURE_LO_INQ	Always 0		
5C0h	CAPTURE_SIZE_INQ	Always 0		
5C4h	CAPTURE_QUALITY_INQ	Always 0		
5C8h .. 5FCh	Reserved for other FEATURE_LO_INQ	Always 0		

Table 115: **Feature elements** inquiry register

Status and control registers for camera

Register	Name	Field	Bit	Description
600h	CUR-V-Frm_RATE/Revision	Bit [0..2] for the frame rate		
604h	CUR-V-MODE	Bit [0..2] for the current video mode		
608h	CUR-V-FORMAT	Bit [0..2] for the current video format		
60Ch	ISO-Channel	Bit [0..3] for channel, [6..7] for ISO speed		
610h	Camera_Power		Always 0	
614h	ISO_EN/Continuous_Shot	Bit 0: 1 for start continuous shot; 0 for stop continuous shot		
618h	Memory_Save		Always 0	
61Ch	One_Shot, Multi_Shot, Count Number		See Chapter One-shot on page 156 See Chapter Multi-shot on page 159	
620h	Mem_Save_Ch		Always 0	
624	Cur_Mem_Ch		Always 0	
628h	Vmode_Error_Status		Error in combination of Format/Mode/ISO Speed: Bit(0): No error; Bit(0)=1: error	
62Ch	Software_Trigger	Software trigger Write: 0: Reset software trigger 1: Set software trigger (self cleared, when using edge mode; must be set back to 0 manually, when using level mode) Read: 0: Ready (meaning: it's possible to set a software trigger) 1: Busy (meaning: no trigger possible)		

Table 116: **Status and control** registers for camera

Inquiry register for absolute value CSR offset address

Offset	Name	Description
700h	ABS_CSR_HI_INQ_0	Always 0
704h	ABS_CSR_HI_INQ_1	Always 0
708h	ABS_CSR_HI_INQ_2	Always 0
70Ch	ABS_CSR_HI_INQ_3	Always 0
710h	ABS_CSR_HI_INQ_4	Always 0
714h	ABS_CSR_HI_INQ_5	Always 0
718h	ABS_CSR_HI_INQ_6	Always 0
71Ch	ABS_CSR_HI_INQ_7	Always 0
720h	ABS_CSR_HI_INQ_8	Always 0
724h	ABS_CSR_HI_INQ_9	Always 0
728h	ABS_CSR_HI_INQ_10	Always 0
72Ch	ABS_CSR_HI_INQ_11	Always 0
730h	ABS_CSR_HI_INQ_12	Always 0
734 .. 77Fh	Reserved	Always 0
780h	ABS_CSR_LO_INQ_0	Always 0
784h	ABS_CSR_LO_INQ_1	Always 0
788h	ABS_CSR_LO_INQ_2	Always 0
78Ch	ABS_CSR_LO_INQ_3	Always 0
790h .. 7BFh	Reserved	Always 0
7C0h	ABS_CSR_LO_INQ_16	Always 0
7C4h	ABS_CSR_LO_INQ_17	Always 0
7C8h .. 7FFh	Reserved	Always 0

Table 117: **Absolute value** inquiry register

Status and control register for one-push

The **OnePush** feature, **WHITE_BALANCE**, is currently implemented. If this flag is set, the feature becomes immediately active, even if no images are being input (see Chapter [One-push white balance](#) on page 98).

Offset	Name	Field	Bit	Description
800h	BRIGHTNESS	Presence_Inq	[0]	Presence of this feature 0: N/A 1: Available
		Abs_Control	[1]	Absolute value control 0: Control with value in the Value field 1: Control with value in the Absolute value CSR If this bit = 1, value in the Value field is ignored.
		---	[2-4]	Reserved
		One_Push	[5]	Write 1: begin to work (Self cleared after operation) Read: Value=1 in operation Value=0 not in operation If A_M_Mode =1, this bit is ignored.
		ON_OFF	[6]	Write: ON or OFF this feature Read: read a status 0: OFF, 1: ON If this bit =0, other fields will be read only.
		A_M_Mode	[7]	Write: set the mode Read: read a current mode 0: Manual 1: Auto
		---	[8-19]	Reserved
		Value	[20-31]	Value. Write the value in Auto mode, this field is ignored. If ReadOut capability is not available, read value has no meaning.

Table 118: **Feature** control register

Offset	Name	Field	Bit	Description
804h	AUTO-EXPOSURE			See above Note: Target grey level parameter in SmartView corresponds to Auto_exposure register 0xF0F00804 (IIDC).

Table 118: **Feature** control register

Offset	Name	Field	Bit	Description
80Ch	WHITE-BALANCE	Presence_Inq	[0]	Presence of this feature 0: N/A 1: Available Always 0 for Mono
		Abs_Control	[1]	Absolute value control 0: Control with value in the Value field 1: Control with value in the Absolute value CSR If this bit = 1, value in the Value field is ignored.
		---	[2-4]	Reserved
		One_Push	[5]	Write 1: begin to work (Self cleared after operation) Read: Value=1 in operation Value=0 not in operation If A_M_Mode =1, this bit is ignored.
		ON_OFF	[6]	Write: ON or OFF this feature, Read: read a status 0: OFF 1: ON If this bit =0, other fields will be read only.
		A_M_Mode	[7]	Write: set the mode Read: read a current mode 0: Manual 1: Auto
		U_Value / B_Value	[8-19]	U value / B value Write the value in AUTO mode, this field is ignored. If ReadOut capability is not available, read value has no meaning.
		V_Value / R_Value	[20-31]	V value / R value Write the value in AUTO mode, this field is ignored. If ReadOut capability is not available, read value has no meaning.

Table 118: **Feature** control register

Offset	Name	Field	Bit	Description
810h	HUE			See above Always 0 for Mono
814h	SATURATION			See above Always 0 for Mono
818h	GAMMA			See above
81Ch	SHUTTER			See Advanced Feature time base See Table 42: CSR: Shutter on page 102
820h	GAIN			See above
824h	IRIS			Always 0
828h	FOCUS			Always 0
830h	TRIGGER_MODE			Can be effected via advanced feature IO_INP_CTRLx.
834h .. 87C	Reserved for other FEATURE_HI			Always 0
880h	Zoom			Always 0
884h	PAN			Always 0
888h	TILT			Always 0
88Ch	OPTICAL_FILTER			Always 0
890 .. 8BCh	Reserved for other FEATURE_LO			Always 0
8C0h	CAPTURE-SIZE			Always 0
8C4h	CAPTURE-QUALITY			Always 0
8C8h .. 8FCh	Reserved for other FEATURE_LO			Always 0

Table 118: Feature control register

Feature control error status register

Offset	Name	Description
640h	Feature_Control_Error_Status_HI	Always 0
644h	Feature_Control_Error_Status_LO	Always 0

Table 119: Feature control error register

Video mode control and status registers for Format_7

Quadlet offset Format_7 Mode_0

The quadlet offset to the base address for **Format_7 Mode_0**, which can be read out at F0F002E0h (according to [Table 112: Frame rate inquiry register](#) on page 213) gives 003C2000h.

$4 \times 3C2000h = F08000h$ so that the base address for the latter ([Table 120: Format_7 control and status register](#) on page 234) equals $F0000000h + F08000h = F0F08000h$.

Quadlet offset Format_7 Mode_1

The quadlet offset to the base address for **Format_7 Mode_1**, which can be read out at F0F002E4h (according to [Table 112: Frame rate inquiry register](#) on page 213) gives 003C2400h.

$4 \times 003C2400h = F09000h$ so that the base address for the latter ([Table 120: Format_7 control and status register](#) on page 234) equals $F0000000h + F09000h = F0F09000h$.

Format_7 control and status register (CSR)

Offset	Name	Description
000h	MAX_IMAGE_SIZE_INQ	According to IIDC V1.31
004h	UNIT_SIZE_INQ	According to IIDC V1.31
008h	IMAGE_POSITION	According to IIDC V1.31
00Ch	IMAGE_SIZE	According to IIDC V1.31
010h	COLOR_CODING_ID	See note
014h	COLOR_CODING_INQ	According to IIDC V1.31
024h . . 033h	COLOR_CODING_INQ	Vendor Unique Color_Coding 0-127 (ID=128-255) ID=132 ECCID_MONO12 ID=136 ECCID_RAW12 ID=133 Reserved ID=134 Reserved ID=135 Reserved See Chapter Packed 12-Bit Mode on page 133.
034h	PIXEL_NUMER_INQ	According to IIDC V1.31
038h	TOTAL_BYTES_HI_INQ	According to IIDC V1.31
03Ch	TOTAL_BYTES_LO_INQ	According to IIDC V1.31

Table 120: **Format_7** control and status register

Offset	Name	Description
040h	PACKET_PARA_INQ	See note
044h	BYTE_PER_PACKET	According to IIDC V1.31

Table 120: **Format_7** control and status register

Note



- For all modes in **Format_7**, **ErrorFlag_1** and **ErrorFlag_2** are refreshed on each access to the **Format_7** register.
- Contrary to IIDC V1.31, registers relevant to **Format_7** are refreshed on each access. The **Setting_1** bit is automatically cleared after each access.
- When **ErrorFlag_1** or **ErrorFlag_2** are set and **Format_7** is configured, no image capture is started.
- Contrary to IIDC V1.31, **COLOR_CODING_ID** is set to a default value after an **INITIALIZE** or **reset**.
- Contrary to IIDC V1.31, the **UnitBytePerPacket** field is already filled in with a fixed value in the **PACKET_PARA_INQ** register.

Advanced features (AVT-specific)

The camera has a variety of extended features going beyond the possibilities described in IIDC V1.31. The following chapter summarizes all available (AVT-specific) advanced features in ascending register order.

Note This chapter is a **reference guide for advanced registers** and does not explain the advanced features itself.



For detailed description of the theoretical background see

- Chapter [Description of the data path](#) on page 94
- Links given in the table below

Advanced registers summary

The following table gives an overview of **all available advanced registers**:

Register	Register name	Description
0xF100010	VERSION_INFO1	See Table 122: Advanced register: Extended version information on page 238
0xF100014	VERSION_INFO1_EX	
0xF100018	VERSION_INFO3	
0xF10001C	VERSION_INFO3_EX	
0xF100040	ADV_INQ_1	See Table 124: Advanced register: Advanced feature inquiry on page 241
0xF100044	ADV_INQ_2	
0xF100048	ADV_INQ_3	In ADV_INQ_3 there is a new field F7MODE_MAPPING [3] Low-noise Binning [9]
0xF10004C	ADV_INQ_4	
0xF1000100	CAMERA_STATUS	See Table 125: Advanced register: Camera status on page 243
0xF1000200	MAX_RESOLUTION	See Table 126: Advanced register: Maximum resolution inquiry on page 244
0xF1000208	TIMEBASE	See Table 127: Advanced register: Time base on page 244
0xF100020C	EXTD_SHUTTER	See Table 129: Advanced register: Extended shutter on page 246
0xF1000210	TEST_IMAGE	See Table 130: Advanced register: Test images on page 247
0xF1000240	LUT_CTRL	See Table 131: Advanced register: LUT on page 248
0xF1000244	LUT_MEM_CTRL	
0xF1000248	LUT_INFO	

Table 121: Advanced registers summary

Register	Register name	Description
0xF1000298	DEFECT_PIXEL_CORRECTION	Defect pixel correction (only Guppy PRO F-503 CMOS) See Table 132: Advanced register: Defect pixel correction on page 250
0xF100029C		
0xF10002A0		
0xF1000300	IO_INP_CTRL1	Guppy PRO housing See Table 23: Advanced register: Input control on page 76
0xF1000320	IO_OUTP_CTRL1	Guppy PRO housing See Table 29: Advanced register: Output control on page 82
0xF1000324	IO_OUTP_CTRL2	
0xF1000328	IO_OUTP_CTRL3	
0xF1000340	IO_INTENA_DELAY	See Table 133: Advanced register: Delayed Integration Enable (IntEna) on page 253
0xF1000360	AUTOSHUTTER_CTRL	See Table 134: Advanced register: Auto shutter control on page 254
0xF1000364	AUTOSHUTTER_LO	
0xF1000368	AUTOSHUTTER_HI	
0xF1000370	AUTOGAIN_CTRL	See Table 135: Advanced register: Auto gain control on page 255
0xF1000390	AUTOFNC_AOI	See Table 136: Advanced register: Autofunction AOI on page 256
0xF1000394	AF_AREA_POSITION	
0xF1000398	AF_AREA_SIZE	
0xF10003A0	COLOR_CORR	Guppy PRO color cameras only See Table 137: Advanced register: Color correction on page 257
0xF1000400	TRIGGER_DELAY	See Table 138: Advanced register: Trigger delay on page 258
0xF1000410	MIRROR_IMAGE	See Table 139: Advanced register: Mirror on page 258
0xF1000510	SOFT_RESET	See Table 140: Advanced register: Soft reset on page 259
0xF1000550	USER_PROFILES	See Table 146: Advanced register: User profiles on page 265
0xF1000580	F7MODE_MAPPING	See Table 143: Advanced register: Format_7 mode mapping on page 262
0xF1000640	SWFEATURE_CTRL	See Table 145: Advanced register: Software feature control (disable LEDs) on page 264

Table 121: **Advanced registers** summary

Register	Register name	Description
0xF1000800 0xF1000804	IO_OUTP_PWM1	Guppy PRO housing See Table 31: PWM configuration registers on page 85
0xF1000808 0xF100080C	IO_OUTP_PWM2	
0xF1000810 0xF1000814	IO_OUTP_PWM3	
0xF1000840	IO_INP_DEBOUNCE_1	See Table 60: Advanced register: Debounce time for input ports on page 152
0xF1000850	IO_INP_DEBOUNCE_2	
0xF1000860	IO_INP_DEBOUNCE_3	
0xF1000870	IO_INP_DEBOUNCE_4	
0xF1000FFC	GPDATA_INFO	See Table 150: Advanced register: GPData buffer on page 269
0xF1001000	GPDATA_BUFFER	
...		
0xF100nnnn		

Table 121: **Advanced registers** summary

Note Advanced features should always be activated before accessing them.



Note

- Currently all registers can be written without being activated. This makes it easier to operate the camera using **Directcontrol**.
- AVT reserves the right to require activation in future versions of the software.



Extended version information register

The presence of each of the following features can be queried by the **0** bit of the corresponding register.

Register	Name	Field	Bit	Description
0xF1000010	VERSION_INFO1	µC type ID	[0..15]	Always 0
		µC version	[16..31]	Bcd-coded version number
0xF1000014	VERSION_INFO1_EX	µC version	[0..31]	Bcd-coded version number

Table 122: Advanced register: **Extended version** information

Register	Name	Field	Bit	Description
0xF1000018	VERSION_INFO3	Camera type ID	[0..15]	See Table 123: Camera type ID list on page 240.
		FPGA version	[16..31]	Bcd-coded version number
0xF100001C	VERSION_INFO3_EX	FPGA version	[0..31]	Bcd-coded version number
0xF1000020		---	[0..31]	Reserved
0xF1000024		---	[0..31]	Reserved
0xF1000028		---	[0..31]	Reserved
0xF100002C		---	[0..31]	Reserved
0xF1000030		OrderIDHigh	[0..31]	8 Byte ASCII Order ID
0xF1000034		OrderIDLow	[0..31]	

Table 122: Advanced register: **Extended version** information

The μ C version and FPGA firmware version numbers are bcd-coded, which means that e.g. firmware version 0.85 is read as 0x0085 and version 1.10 is read as 0x0110.

The newly added **VERSION_INFOx_EX** registers contain extended bcd-coded version information formatted as *special.major.minor.patch*.

So reading the value **0x00223344** is decoded as:

- special: 0 (decimal)
- major: 22 (decimal)
- minor: 33 (decimal)
- patch: 44 (decimal)

This is decoded to the human readable version **22.33.44** (leading zeros are omitted).

Note If a camera returns the register set to all zero, that particular camera does not support the extended version information.



The FPGA type ID (= camera type ID) identifies the camera type with the help of the following list:

ID	Camera type
501	Guppy PRO F-031B
502	Guppy PRO F-031C
503	Guppy PRO F-032B
504	Guppy PRO F-032C
---	---
---	---
511	Guppy PRO F-125B
512	Guppy PRO F-125C
---	---
---	---
515	Guppy PRO F-146B
516	Guppy PRO F-146C
517	Guppy PRO F-201B
518	Guppy PRO F-201C
519	Guppy PRO F-503B
520	Guppy PRO F-503C
---	---
---	---

Table 123: Camera type ID list

Advanced feature inquiry

This register indicates with a named bit if a feature is present or not. If a feature is marked as not present the associated register space might not be available and read/write errors may occur.

Note Ignore unnamed bits in the following table: these bits might be set or not.



Register	Name	Field	Bit	Description
0xF100040	ADV_INQ_1	MaxResolution	[0]	
		TimeBase	[1]	
		ExtdShutter	[2]	
		TestImage	[3]	
		---	[4]	Reserved
		Sequences	[5]	
		VersionInfo	[6]	
		---	[7]	Reserved
		Look-up tables	[8]	
		---	[9]	Reserved
		---	[10]	Reserved
		---	[11]	Reserved
		---	[12]	Reserved
		---	[13]	Reserved
		TriggerDelay	[14]	
		Mirror image	[15]	
		Soft Reset	[16]	
		---	[17]	Reserved
		---	[18]	Reserved
		---	[19..20]	Reserved
		User Sets	[21]	
		---	[22..29]	Reserved
Paramlist_Info	[30]			
GP_Buffer	[31]			

Table 124: Advanced register: **Advanced feature inquiry**

Register	Name	Field	Bit	Description
0xF100044	ADV_INQ_2	Input_1	[0]	
		---	[1]	Reserved
		---	[2..7]	Reserved
		Output_1	[8]	
		Output_2	[9]	
		Output_3	[10]	
		---	[11]	Reserved
		---	[12..15]	Reserved
		IntEnaDelay	[16]	
		---	[17..23]	Reserved
		Output 1 PWM	[24]	Guppy PRO housing
		Output 2 PWM	[25]	
		Output 3 PWM	[26]	
		---	[27..31]	Reserved
0xF100048	ADV_INQ_3	Camera Status	[0]	
		Max IsoSize	[1]	
		Paramupd_Timing	[2]	
		F7 mode mapping	[3]	
		Auto Shutter	[4]	
		Auto Gain	[5]	
		Auto FNC AOI	[6]	
		---	[7..11]	Reserved
		Defect Pixel Correction	[12]	
		---	[13..31]	Reserved
0xF10004C	ADV_INQ_4	---	[0]	
		---	[1]	
		---	[2]	
		---	[18..31]	Reserved

Table 124: Advanced register: **Advanced feature inquiry**

Camera status

This register allows to determine the current status of the camera. The most important flag is the **Idle** flag.

If the **Idle** flag is set the camera does not capture and does not send any images.

The **ExSyncArmed** flag indicates that the camera is set up for external triggering. Even if the camera is waiting for an external trigger event the **Idle** flag might get set.

Other bits in this register might be set or toggled: just ignore these bits.

Note



- Excessive polling of this register may slow down the operation of the camera. Therefore the time between two polls of the status register should not be less than 5 milliseconds. If the time between two read accesses is lower than 5 milliseconds the response will be delayed.
- Depending on shutter and isochronous settings the status flags might be set for a very short time and thus will not be recognized by your application.

Register	Name	Field	Bit	Description
0xF1000100	CAMERA_STATUS	Presence_Inq	[0]	Indicates presence of this feature (read only)
		---	[1..23]	Reserved
		ID	[24..31]	Implementation ID = 0x01
0xF1000104		---	[0..14]	Reserved
		ExSyncArmed	[15]	External trigger enabled
		---	[16..27]	Reserved
		ISO	[28]	Isochronous transmission
		---	[29..30]	Reserved
		Idle	[31]	Camera idle

Table 125: Advanced register: **Camera status**

Maximum resolution

This register indicates the highest resolution for the sensor and is read-only.

Note This register normally outputs the MAX_IMAGE_SIZE_INQ Format_7 Mode_0 value.



This is the value given in the specifications tables under **Picture size (max.)** in Chapter [Specifications](#) on page 38ff.

Register	Name	Field	Bit	Description
0xF1000200	MAX_RESOLUTION	MaxWidth	[0..15]	Sensor width (read only)
		MaxHeight	[16..31]	Sensor height (read only)

Table 126: Advanced register: **Maximum resolution** inquiry

Time base

Corresponding to IIDC, exposure time is set via a 12-bit value in the corresponding register (SHUTTER_INQ [51Ch] and SHUTTER [81Ch]).

This means that you can enter a value in the range of 1 to 4095.

Guppy PRO cameras use a time base which is multiplied by the shutter register value. This multiplier is configured as the time base via the TIMEBASE register.

Register	Name	Field	Bit	Description
0xF1000208	TIMEBASE	Presence_Inq	[0]	Indicates presence of this feature (read only)
		---	[1..7]	Reserved
		ExpOffset	[8..19]	Exposure offset in μ s
		---	[20..27]	Reserved
		Timebase_ID	[28..31]	See Table 128: Time base ID on page 245.

Table 127: Advanced register: **Time base**

The time base IDs 0-9 are in bit [28] to [31]. See [Table 128: Time base ID](#) on page 245. Refer to the following table for code.

Default time base is 20 μ s: This means that the integration time can be changed in 20 μ s increments with the shutter control.

Note Time base can only be changed when the camera is in idle state and becomes active only after setting the shutter value.



The **ExpOffset** field specifies the camera specific exposure time offset in microseconds (μs). This time (which should be equivalent to [Table 61: Camera-specific exposure time offset](#) on page 154) has to be added to the exposure time (set by any shutter register) to compute the real exposure time.

The **ExpOffset** field might be zero for some cameras: this has to be assumed as an unknown exposure time offset (according to former software versions).

ID	Time base in μs	
0	1	
1	2	
2	5	
3	10	
4	20	Default value
5	50	
6	100	
7	200	
8	500	
9	1000	

Table 128: Time base ID

Note The ABSOLUTE VALUE CSR register, introduced in IIDC V1.3, is not implemented.



Extended shutter

The exposure time for long-term integration of up to 67 seconds can be entered with μ s precision via the EXTENDED_SHUTTER register.

Register	Name	Field	Bit	Description
0xF10020C	EXTD_SHUTTER	Presence_Inq	[0]	Indicates presence of this feature (read only)
		---	[1..5]	Reserved
		ExpTime	[6..31]	Exposure time in μ s

Table 129: Advanced register: **Extended shutter**

The minimum allowed exposure time depends on the camera model. To determine this value write **1** to the **ExpTime** field and read back the minimum allowed exposure time.

The longest exposure time, 3FFFFFFh, corresponds to 67.11 seconds.

Note



- Exposure times entered via the 81Ch register are mirrored in the extended register, but not vice versa.
- Changes in this register have immediate effect, even when camera is transmitting.
- Extended shutter becomes inactive after writing to a format / mode / frame rate register.
- Extended shutter setting will thus be overwritten by the normal time base/shutter setting after Stop/Start of FireView or FireDemo.

Test images

Bit [8] to [14] indicate which test images are saved. Setting bit [28] to [31] activates or deactivates existing test images.

By activating any test image the following auto features are automatically disabled:

- auto gain
- auto shutter
- auto white balance

Register	Name	Field	Bit	Description
0xF1000210	TEST_IMAGE	Presence_Inq	[0]	Indicates presence of this feature (read only)
		---	[1..7]	Reserved
		Image_Inq_1	[8]	Presence of test image 1 0: N/A 1: Available
		Image_Inq_2	[9]	Presence of test image 2 0: N/A 1: Available
		Image_Inq_3	[10]	Presence of test image 3 0: N/A 1: Available
		Image_Inq_4	[11]	Presence of test image 4 0: N/A 1: Available
		Image_Inq_5	[12]	Presence of test image 5 0: N/A 1: Available
		Image_Inq_6	[13]	Presence of test image 6 0: N/A 1: Available
		Image_Inq_7	[14]	Presence of test image 7 0: N/A 1: Available
		---	[15..27]	Reserved
	TestImage_ID	[28..31]	0: No test image active 1: Image 1 active 2: Image 2 active ...	

Table 130: Advanced register: **Test images**

Look-up tables (LUT)

Load the look-up tables to be used into the camera and choose the look-up table number via the **LutNo** field. Now you can activate the chosen LUT via the LUT_CTRL register.

The LUT_INFO register indicates how many LUTs the camera can store and shows the maximum size of the individual LUTs.

The possible values for **LutNo** are 0..n-1, whereas n can be determined by reading the field **NumOfLuts** of the LUT_INFO register.

Register	Name	Field	Bit	Description
0xF1000240	LUT_CTRL	Presence_Inq	[0]	Indicates presence of this feature (read only)
		---	[1..5]	Reserved
		ON_OFF	[6]	Enable/disable this feature
		---	[7..25]	Reserved
		LutNo	[26..31]	Use look-up table with LutNo number
0xF1000244	LUT_MEM_CTRL	Presence_Inq	[0]	Indicates presence of this feature (read only)
		---	[1..4]	Reserved
		EnableMemWR	[5]	Enable write access
		---	[6..7]	Reserved
		AccessLutNo	[8..15]	
		AddrOffset	[16..31]	byte
0xF1000248	LUT_INFO	Presence_Inq	[0]	Indicates presence of this feature (read only)
		---	[1..2]	Reserved
		BitsPerValue	[3..7]	Bits used per table item
		NumOfLuts	[8..15]	Maximum number of look-up tables
		MaxLutSize	[16..31]	Maximum look-up table size (bytes)

Table 131: Advanced register: **LUT**

Note

The **BitsPerValue** field indicates how many bits are read from the LUT for any grey-value read from the sensor. To determine the number of bytes occupied for each grey-value round-up the **BitsPerValue** field to the next byte boundary.

Examples:

- BitsPerValue = 8 → 1 byte per grey-value
- BitsPerValue = 14 → 2 byte per grey-value

Divide **MaxLutSize** by the number of bytes per grey-value in order to get the number of LUT entries (grey levels): that is 2^n with n =number of bits read from sensor.

Note

Guppy PRO cameras have the gamma feature implemented via a built-in look-up table. Therefore you can not use gamma and your own look-up table at the same time. Nevertheless you may combine a gamma look-up table into your own look-up table.

Note

When using the LUT feature and the gamma feature pay attention to the following:

- gamma ON → look-up table is switched ON also
- gamma OFF → look-up table is switched OFF also
- look-up table OFF → gamma is switched OFF also
- look-up table ON → gamma is switched OFF

Loading a look-up table into the camera

Loading a look-up table into the camera is done through the Gpdata_BUFFER. Because the size of the Gpdata_BUFFER is smaller than a complete look-up table the data must be written in multiple steps.

To load a lookup table into the camera:

1. Query the limits and ranges by reading LUT_INFO and Gpdata_INFO.
2. Set **EnableMemWR** to true (1).
3. Set **AccessLutNo** to the desired number.
4. Set **AddrOffset** to 0.
5. Write n lookup table data bytes to Gpdata_BUFFER (n might be lower than the size of the Gpdata_BUFFER; AddrOffset is automatically adjusted inside the camera).
6. Repeat step 5 until all data is written into the camera.
7. Set **EnableMemWR** to false (0).

Defect pixel correction

Definition The defect pixel correction mode allows to correct an image with defect pixels. Via threshold you can define the defect pixels in an image. Defect pixel correction is done in the FPGA and defect pixel data can be stored inside the camera.

DPC = defect pixel correction

WR = write

RD = read

MEM, Mem = memory

Note



- Defect pixel correction is always done in **Format_7 Mode_0**.
- When using defect pixel correction with **binning** and **sub-sampling**: first switch to binning/sub-sampling modus and then apply defect pixel correction.

Register	Name	Field	Bit	Description
0xF100298	DPC_CTRL	Presence_Inq	[0]	Indicates presence of this feature (read only)
		BuildError	[1]	Build defect pixel data that reports an error, e.g. more than 2000 defect pixels, see DPDataSize.
		---	[2..4]	Reserved
		BuildDPData	[5]	Build defect pixel data now
		ON_OFF	[6]	Enable/disable this feature
		Busy	[7]	Build defect pixel data in progress
		MemSave	[8]	Save defect pixel data to storage
		MemLoad	[9]	Load defect pixel data from storage
		ZeroDPData	[10]	Zero defect pixel data
		---	[11..17]	Reserved
		Mean	[18..24]	Calculated mean value (7 bit)
		Threshold	[25..31]	Threshold for defect pixel correction

Table 132: Advanced register: **Defect pixel correction**

Register	Name	Field	Bit	Description
0xF100029C	DPC_MEM	Presence_Inq	[0]	Indicates presence of this feature (read only)
		---	[1]	Reserved
		EnaMemWR	[2]	Enable write access from host to RAM
		EnaMemRD	[3]	Enable read access from RAM to host
		DPDataSize	[4..17]	Size of defect pixel data to read from RAM to host. A maximum of 2000 defect pixels can be stored. To get the number of defect pixels read out this value and divide by 4. In case of more than 2000 defect pixels, DPDataSize is set to 2001 pixels (DPDataSize of 8004 divided by 4 equals 2001 pixels) and BuildError flag is set to 1. Defect pixel correction data is done with first 2000 defect pixels only.
AddrOffset	[18..31]	Address offset to selected defect pixel data		
0xF10002A0	DPC_INFO	Presence_Inq	[0]	Indicates presence of this feature (read only)
		---	[1..3]	Reserved
		MinThreshold	[4..10]	Minimum value for threshold
		MaxThreshold	[11..17]	Maximum value for threshold
		MaxSize	[18..31]	Maximum size of defect pixel data

Table 132: Advanced register: **Defect pixel correction**

Input/output pin control

Note



- See Chapter [Input/output pin control](#) on page 76
- See Chapter [IO_INP_CTRL 1](#) on page 77
- See Chapter [IO_OUTP_CTRL 1-3](#) on page 82
- See Chapter [Output modes](#) on page 83

Delayed Integration Enable (IntEna)

A delay time between initiating exposure on the sensor and the activation edge of the **IntEna** signal can be set using this register. The **on/off** flag activates/deactivates integration delay. The time can be set in μs in **DelayTime**.

Note



- Only one edge is delayed.
- If **IntEna_Out** is used to control an exposure, it is possible to have a variation in brightness or to precisely time a flash.

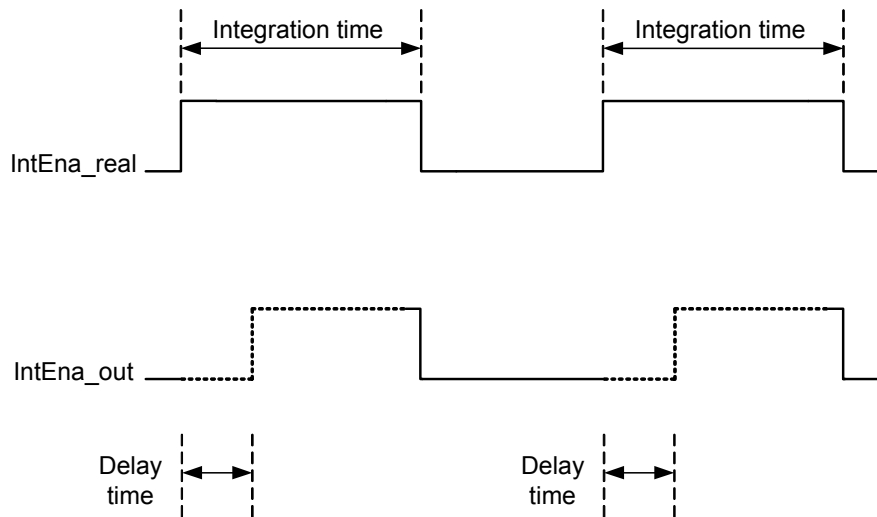

Figure 90: Delayed integration timing

Register	Name	Field	Bit	Description
0xF1000340	IO_INTENA_DELAY	Presence_Inq	[0]	Indicates presence of this feature (read only)
		---	[1..5]	Reserved
		ON_OFF	[6]	Enable/disable integration enable delay
		---	[7..11]	Reserved
		DELAY_TIME	[12..31]	Delay time in μs

Table 133: Advanced register: **Delayed Integration Enable (IntEna)**

Auto shutter control

The table below illustrates the advanced register for **auto shutter control**. The purpose of this register is to limit the range within which auto shutter operates.

Register	Name	Field	Bit	Description
0xF1000360	AUTOSHUTTER_CTRL	Presence_Inq	[0]	Indicates presence of this feature (read only)
		---	[1..31]	Reserved
0xF1000364	AUTOSHUTTER_LO	---	[0..5]	Reserved
		MinValue	[6..31]	Minimum auto shutter value lowest possible value: 10 μ s
0xF1000368	AUTOSHUTTER_HI	---	[0..5]	Reserved
		MaxValue	[6..31]	Maximum auto shutter value

Table 134: Advanced register: **Auto shutter control**

Note



- Values can only be changed within the limits of shutter CSR.
- Changes in auto exposure register only have an effect when auto shutter is enabled.
- Auto exposure limits are: 50..205 (**SmartView** → **Ctrl1 tab: Target grey level**)

When both **auto shutter** and **auto gain** are enabled, priority is given to increasing shutter when brightness decreases. This is done to achieve the best image quality with lowest noise.

For increasing brightness, priority is given to lowering gain first for the same purpose.

MinValue and **MaxValue** limits the range the auto shutter feature is allowed to use for the regulation process. Both values are initialized with the minimum and maximum value defined in the standard SHUTTER_INQ register (multiplied by the current active timebase).

If you change the **MinValue** and/or **MaxValue** and the new range exceeds the range defined by the SHUTTER_INQ register, the standard SHUTTER register will not show correct shutter values. In this case you should read the EXTENDED_SHUTTER register for the current active shutter time.

Changing the auto shutter range might not affect the regulation, if the regulation is in a stable condition and no other condition affecting the image brightness is changed.

If both **auto gain** and **auto shutter** are enabled and if the shutter is at its upper boundary and gain regulation is in progress, increasing the upper auto shutter boundary has no effect on auto gain/shutter regulation as long as auto gain regulation is active.

Note As with the Extended Shutter the value of **MinValue** and **MaxValue** must not be set to a lower value than the minimum shutter time.



Auto gain control

The table below illustrates the advanced register for **auto gain control**.

Register	Name	Field	Bit	Description
0xF100370	AUTOGAIN_CTRL	Presence_Inq	[0]	Indicates presence of this feature (read only)
		---	[1..3]	Reserved
		MaxValue	[4..15]	Maximum auto gain value
		---	[16..19]	Reserved
		MinValue	[20..31]	Minimum auto gain value

Table 135: Advanced register: **Auto gain control**

MinValue and **MaxValue** limits the range the auto gain feature is allowed to use for the regulation process. Both values are initialized with the minimum and maximum value defined in the standard GAIN_INQ register.

Changing the **auto gain range** might not affect the regulation, if the regulation is in a stable condition and no other condition affecting the image brightness is changed.

If both **auto gain** and **auto shutter** are enabled and if the gain is at its lower boundary and shutter regulation is in progress, decreasing the lower auto gain boundary has no effect on auto gain/shutter regulation as long as auto shutter regulation is active.

Both values can only be changed within the range defined by the standard GAIN_INQ register.

Autofunction AOI

The table below illustrates the advanced register for **autofunction AOI**.

Register	Name	Field	Bit	Description
0xF1000390	AUTOFNC_AOI	Presence_Inq	[0]	Indicates presence of this feature (read only)
		---	[1..3]	Reserved
		ShowWorkArea	[4]	Show work area
		---	[5]	Reserved
		ON_OFF	[6]	Enable/disable AOI (see note above)
		---	[7]	Reserved
		YUNITS	[8..19]	Y units of work area/pos. beginning with 0 (read only)
0xF1000394	AF_AREA_POSITION	Left	[0..15]	Work area position (left coordinate)
		Top	[16..31]	Work area position (top coordinate)
0xF1000398	AF_AREA_SIZE	Width	[0..15]	Width of work area size
		Height	[16..31]	Height of work area size

Table 136: Advanced register: **Autofunction AOI**

The possible increment of the work area position and size is defined by the YUNITS and XUNITS fields. The camera automatically adjusts your settings to permitted values.

Note



If the adjustment fails and the work area size and/or work area position becomes invalid, then this feature is automatically switched off.

Read back the ON_OFF flag, if this feature does not work as expected.

Color correction

To switch off color correction in YUV mode: see bit [6]

Register	Name	Field	Bit	Description
0xF10003A0	COLOR_CORR	Presence_Inq	[0]	Indicates presence of this feature (read only)
		---	[1..5]	Reserved
		ON_OFF	[6]	Color correction on/off default: on Write: 02000000h to switch color correction OFF Write: 00000000h to switch color correction ON
		Reset	[7]	Reset to defaults
		---	[8..31]	Reserved
0xF10003A4	COLOR_CORR_COEFFIC11 = Crr		[0..31]	A number of 1000 equals a color correction coefficient of 1. Color correction values range -1000..+2000 and are signed 32 bit . In order for white balance to work properly ensure that the row sum equals to 1000. The maximum row sum is limited to 2000.
0xF10003A8	COLOR_CORR_COEFFIC12 = Cgr		[0..31]	
0xF10003AC	COLOR_CORR_COEFFIC13 = Cbr		[0..31]	
0xF10003B0	COLOR_CORR_COEFFIC21 = Crg		[0..31]	
0xF10003B4	COLOR_CORR_COEFFIC22 = Cgg		[0..31]	
0xF10003B8	COLOR_CORR_COEFFIC23 = Cbg		[0..31]	
0xF10003BC	COLOR_CORR_COEFFIC31 = Crb		[0..31]	
0xF10003C0	COLOR_CORR_COEFFIC32 = Cgb		[0..31]	
0xF10003C4	COLOR_CORR_COEFFIC33 = Cbb		[0..31]	
0xF10003A4 ... 0xF10003FC				

Table 137: Advanced register: **Color correction**

For an explanation of the color correction matrix and for further information read Chapter [Color correction](#) on page 136.

Trigger delay

Register	Name	Field	Bit	Description
0xF1000400	TRIGGER_DELAY	Presence_Inq	[0]	Indicates presence of this feature (read only)
		---	[1..5]	Reserved
		ON_OFF	[6]	Trigger delay on/off
		---	[7..10]	Reserved
		DelayTime	[11..31]	Delay time in μ s

Table 138: Advanced register: **Trigger delay**

The advanced register allows start of the integration to be delayed via **DelayTime** by max. 2^{21} μ s, which is max. 2.1 s after a trigger edge was detected.

Note _____ Trigger delay works with external trigger modes only.



Mirror image

The table below illustrates the advanced register for **Mirror image**. Mirror image is only possible with Guppy PRO F-503.

- With Guppy PRO F-503B, **horizontal and vertical mirror** is possible.
- With Guppy PRO F-503C, only **horizontal mirror** is possible.

Register	Name	Field	Bit	Description
0xF1000410	MIRROR_IMAGE	Presence_Inq	[0]	Indicates presence of this feature (read only)
		---	[1..5]	Reserved
		ON_OFF	[6]	Mirror image on/off 1: on 0: off Default: off
		---	[7..31]	Reserved

Table 139: Advanced register: **Mirror**

Soft reset

Register	Name	Field	Bit	Description
0xF100510	SOFT_RESET	Presence_Inq	[0]	Indicates presence of this feature (read only)
		---	[1..5]	Reserved
		Reset	[6]	Initiate reset
		---	[7..19]	Reserved
		Delay	[20..31]	Delay reset in 10 ms steps

Table 140: Advanced register: **Soft reset**

The **soft reset** feature is similar to the INITIALIZE register, with the following differences:

- 1 or more bus resets will occur
- The FPGA will be rebooted

The reset can be delayed by setting the **Delay** to a value unequal to 0.

The delay is defined in 10 ms steps.

Note When SOFT_RESET has been defined, the camera will respond to further read or write requests but will not process them.



Maximum ISO packet size

Use this feature to increase the MaxBytePerPacket value of Format_7 modes. This overrides the maximum allowed isochronous packet size specified by IIDC V1.31.

Register	Name	Field	Bit	Description
0xF1000560	ISOSIZE_S400	Presence_Inq	[0]	Indicates presence of this feature (read only)
		---	[1..5]	Reserved
		ON_OFF	[6]	Enable/Disable S400 settings
		Set2Max	[7]	Set to maximum supported packet size
		---	[8..15]	Reserved
		MaxIsoSize	[16..31]	Maximum ISO packet size for S400
0xF1000564	ISOSIZE_S800	Presence_Inq	[0]	Indicates presence of this feature (read only)
		---	[1..5]	Reserved
		ON_OFF	[6]	Enable/Disable S800 settings
		Set2Max	[7]	Set to maximum supported packet size
		---	[8..15]	Reserved
		MaxIsoSize	[16..31]	Maximum ISO packet size for S800

Table 141: Advanced register: **Maximum ISO packet size**

Example For isochronous packets at a speed of S800 the maximum allowed packet size (IIDC V1.31) is 8192 byte. This feature allows you to extend the size of an isochronous packet up to 11.000 byte at S800. Thus the isochronous bandwidth is increased from 64 MByte/s to approximately 84 MByte/s. You need either PCI Express or PCI-X (64 bit).

The **Maximum ISO packet size** feature ...

- ... reduces the asynchronous bandwidth available for controlling cameras by approximately 75%
- ... may lead to slower responses on commands
- ... is not covered by the IEEE 1394 specification
- ... may not work with all available 1394 host adapters.

Note We strongly recommend to use **PCI-X (64 bit)** or **PCI Express** adapter.



Restrictions Note the restrictions in the following table. When using software with an Isochronous Resource Manager (IRM): deactivate it.

Software	Restrictions
FireGrab	Deactivate Isochronous Resource Manager: SetParameter (FGP_USEIRMFORBW, 0)
FireStack/FireClass	No restrictions
SDKs using Microsoft driver (Active FirePackage, Direct FirePackage, ...)	n/a
Linux: libdc1394_1.x	No restrictions
Linux: libdc1394_2.x	Deactivate Isochronous Resource Manager: Set DC1394_CAPTURE_FLAGS_BANDWIDTH_ALLOC flag to 0
Third Party Software	Deactivate Isochronous Resource Manager

Table 142: Restrictions for feature: **Maximum ISO packet size**

Operation The maximum allowed isochronous packet size can be set separately for the ISO speeds S400 and S800. Check the associated **Presence_Inq** flag to see for which ISO speed this feature is available.

Setting the **Set2Max** flag to 1 sets the **MaxIsoSize** field to the maximum supported isochronous packet size. Use this flag to query the maximum supported size (may depend on the camera model).

Enable this feature by setting the **ON_OFF** flag to 1 and the **MaxIsoSize** field to a value greater than the default packet size.

The camera ensures:

- that the value of the **MaxIsoSize** field is a multiple of 4.
- that the value isn't lower than the value specified by the IEEE1394 specification.

The settings are stored in the user sets.

Note Enabling this feature will not change the **MaxBytePerPacket** value automatically. The camera may not use the new isochronous packet size for the **MaxBytePerPacket** value until a write access to the desired Format_7 mode has been issued.



Format_7 mode mapping (only Guppy PRO F-503)

With Format_7 mode mapping it is possible to map special binning and sub-sampling modes to F7M1..F7M7. See [page 132](#). For default mappings see [Table 50: Default Format_7 binning and sub-sampling modes \(per factory\)](#) on page 131

Register	Name	Field	Bit	Description
0xF1000580	F7MODE_MAPPING	Presence_Inq	[0]	Indicates presence of this feature (read only)
		---	[1..31]	Reserved
0xF1000584	F7MODE_MAP_INQ	F7MODE_00_INQ	[0]	Format_7 Mode_0 presence
		F7MODE_01_INQ	[1]	Format_7 Mode_1 presence
	
		F7MODE_31_INQ	[31]	Format_7 Mode_31 presence
0xF1000588	Reserved	---	---	---
0xF100058C	Reserved	---	---	---
0xF1000590	F7MODE_0	Format_ID	[0..31]	Format ID (read only)
0xF1000594	F7MODE_1	Format_ID	[0..31]	Format ID for Format_7 Mode_1
0xF1000598	F7MODE_2	Format_ID	[0..31]	Format ID for Format_7 Mode_2
0xF100059C	F7MODE_3	Format_ID	[0..31]	Format ID for Format_7 Mode_3
0xF10005A0	F7MODE_4	Format_ID	[0..31]	Format ID for Format_7 Mode_4
0xF10005A4	F7MODE_5	Format_ID	[0..31]	Format ID for Format_7 Mode_5
0xF10005A8	F7MODE_6	Format_ID	[0..31]	Format ID for Format_7 Mode_6
0xF10005AC	F7MODE_7	Format_ID	[0..31]	Format ID for Format_7 Mode_7

Table 143: Advanced register: **Format_7 mode mapping**

Additional Format_7 modes

With Format_7 mode mapping you can add some special Format_7 modes which aren't covered by the IIDC standard. These special modes implement **binning** and **sub-sampling**.

To stay as close as possible to the IIDC standard the Format_7 modes can be mapped into the register space of the standard Format_7 modes.

There are visible Format_7 modes and internal Format_7 modes:

- At any time only 8 Format_7 modes can be accessed by a host computer.
- Visible Format_7 modes are numbered from 0 to 7.
- Internal Format_7 modes are numbered from 0 to 27.

Format_7 Mode_0 represents the **mode with the maximum resolution** of the camera: this visible mode cannot be mapped to any other internal mode.

The remaining visible Format_7 Mode_1 ... Mode_7 can be mapped to any internal Format_7 mode.

Example

To map the internal Format_7 Mode_19 to the visible Format_7 Mode_1, write the decimal number 19 to the above listed F7MODE_1 register.

Note



For available Format_7 modes see [Figure 63: Mapping of possible Format_7 modes to F7M1...F7M7 \(F-503 only\)](#) For default mappings per factory see [page 180 on page 132](#).

Setting the F7MODE_x register to:

- -1 forces the camera to use the factory defined mode
- -2 disables the respective Format_7 mode (no mapping is applied)

After setup of personal Format_7 mode mappings you have to reset the camera. The mapping is performed during the camera startup only.

Low-noise binning mode (2 x and 4 x binning) (only Guppy PRO F-503)

This register enables/disables **low-noise binning mode**.

This means: an average (and not a sum) of the luminance values is calculated within the FPGA.

The image is therefore darker than with the usual binning mode, but the signal to noise ratio is better (approximately a factor of $\sqrt{2}$).

Offset	Name	Field	Bit	Description
0xF10005B0	LOW_NOISE_BINNING	Presence_Inq	[0]	Indicates presence of this feature (read only)
		---	[1..5]	Reserved
		ON_OFF	[6]	Low-noise binning mode on/off
		---	[7..31]	Reserved

Table 144: Advanced register: **Low-noise binning mode**

Software feature control (disable LED)

The software feature control register allows to enable/disable some features of the camera (e.g. disable LED). The settings are stored permanently within the camera and do not depend on any user set.

Disable LEDs

- To disable LEDs set bit [17] to 1.
- To disable LEDs in SmartView:
Adv3 tab, activate Disable LED functionality check box.

The camera does not show any more the status indicators during normal operation:

Examples:

- Power on is not shown
- Isochronous traffic is not shown
- Asynchronous traffic is not shown

Register	Name	Field	Bit	Description
0xF1000640	SWFEATURE_CTRL	Presence_Inq	[0]	Indicates presence of this feature (read only)
		BlankLED_Inq	[1]	Indicates presence of <i>Disable LEDs</i> feature.
		---	[2..15]	Reserved
		---	[16]	Reserved
		BlankLED	[17]	0: Behavior as described in Chapter Status LEDs on page 72. 1: Disable LEDs. (Only error codes are shown.)
		---	[18..31]	Reserved

Table 145: Advanced register: Software feature control (disable LEDs)

Note



During the startup of the camera and if an error condition is present, the LEDs behave as described in Chapter [Status LEDs](#) on page 93ff.

User profiles

Definition Within the IIDC specification **user profiles** are called **memory channels**. Often they are called **user sets**. In fact these are different expressions for the following: storing camera settings into a non-volatile memory inside the camera.

User profiles can be programmed with the following advanced feature register:

Offset	Name	Field	Bit	Description
0xF1000550	USER_PROFILE	Presence_Inq	[0]	Indicates presence of this feature (read only)
		Error	[1]	An error occurred
		---	[2..6]	Reserved
		Busy	[7]	Save/Load in progress
		Save	[8]	Save settings to profile
		Load	[9]	Load settings from profile
		SetDefaultID	[10]	Set Profile ID as default
		---	[11..19]	Reserved
		ErrorCode	[20..23]	Error code See Table 147: User profiles: Error codes on page 266.
		---	[24..27]	Reserved
	ProfileID	[28..31]	ProfileID (memory channel)	

Table 146: Advanced register: **User profiles**

In general this advanced register is a wrapper around the standard memory channel registers with some extensions. In order to query the number of available user profiles please check the **Memory_Channel** field of the **BASIC_FUNC_INQ** register at offset **0x400** (see IIDC V1.31 for details).

The **ProfileID** is equivalent to the memory channel number and specifies the profile number to store settings to or to restore settings from. In any case profile #0 is the hard-coded factory profile and cannot be overwritten.

After an initialization command, startup or reset of the camera, the **ProfileID** also indicates which profile was loaded on startup, reset or initialization.

Note



- The default profile is the profile that is loaded on power-up or an INITIALIZE command.
- A save or load operation delays the response of the camera until the operation is completed. At a time only one operation can be performed.

Store To store the current camera settings into a profile:

1. Write the desired **ProfileID** with the **SaveProfile** flag set.
2. Read back the register and check the **ErrorCode** field.

Restore To restore the settings from a previous stored profile:

1. Write the desired **ProfileID** with the **RestoreProfile** flag set.
2. Read back the register and check the **ErrorCode** field.

Set default To set the default profile to be loaded on startup, reset or initialization:

1. Write the desired **ProfileID** with the **SetDefaultID** flag set.
2. Read back the register and check the **ErrorCode** field.

Error codes

ErrorCode #	Description
0x00	No error
0x01	Profile data corrupted
0x02	Camera not idle during restore operation
0x03	Feature not available (feature not present)
0x04	Profile does not exist
0x05	ProfileID out of range
0x06	Restoring the default profile failed
0x07	Loading LUT data failed
0x08	Storing LUT data failed

Table 147: User profiles: **Error codes**

Reset of error codes

The **ErrorCode** field is set to zero on the next write access.

You may also reset the **ErrorCode**

- by writing to the **USER_PROFILE** register with the **SaveProfile, RestoreProfile** and **SetDefaultID** flag not set.
- by writing 00000000h to the **USER_PROFILE** register.

Stored settings

The following table shows the settings stored inside a profile:

Standard registers	Standard registers (Format_7)	Advanced registers
Cur_V_Frm_Rate	IMAGE_POSITION (AOI)	TIMEBASE
Cur_V_Mode	IMAGE_SIZE (AOI)	EXTD_SHUTTER
Cur_V_Format	COLOR_CODING_ID	IO_INP_CTRL
ISO_Channel	BYTES_PER_PACKET	IO_OUTP_CTRL
ISO_Speed		IO_INTENA_DELAY
BRIGHTNESS		AUTOSHUTTER_CTRL
AUTO_EXPOSURE (Target grey level)		AUTOSHUTTER_LO
WHITE_BALANCE (+ auto on/off)		AUTOSHUTTER_HI
HUE (+ hue on)		AUTOGAIN_CTRL
SATURATION (+ saturation on)		AUTOFNC_AOI (+ on/off)
GAMMA (+ gamma on)		TRIGGER_DELAY
SHUTTER (+ auto on/off)		MIRROR_IMAGE
GAIN		LUT_CTRL (LutNo; ON_OFF is not saved)
TRIGGER_MODE		
TRIGGER_POLARITY		
TRIGGER_DELAY		
ABS_GAIN		

Table 148: User profile: **stored settings**

The user can specify which user profile will be loaded upon startup of the camera.

This frees the user software from having to restore camera settings, that differ from default, after every startup. This can be especially helpful if third party software is used which may not give easy access to certain advanced features or may not provide efficient commands for quick writing of data blocks into the camera.

Note



- A profile save operation automatically disables capturing of images.
- A profile save or restore operation is an uninterruptable (atomic) operation. The write response (of the asynchronous write cycle) will be sent after completion of the operation.
- Restoring a profile will not overwrite other settings than listed above.
- If a restore operation fails or the specified profile does not exist, all registers will be overwritten with the hard-coded factory defaults (profile #0).
- Data written to this register will not be reflected in the standard memory channel registers.

Pulse-width modulation (PWM)

Note See [Table 31: PWM configuration registers](#) on page 85.



**Global reset release shutter
(only Guppy PRO F-503)**

Offset	Name	Field	Bit	Description
0xF10005C0	GLOBAL_RES_REL_SHUTTER	Presence_Inq	[0]	Indicates presence of this feature (read only)
		---	[1..5]	Reserved
		ON_OFF	[6]	Global reset release shutter on/off. If off, then electronic rolling shutter will be used.
		---	[7..31]	Reserved

Table 149: Advanced register: **Global reset release shutter**

GPDATA_BUFFER

GPDATA_BUFFER is a general purpose register that regulates the exchange of data between camera and host for:

- writing look-up tables (LUTs) into the camera
- uploading/downloading of shading image (not used) and defect pixel correction data (only CMOS cameras)

GPDATA_INFO Buffer size query
GPDATA_BUFFER indicates the actual storage range

Register	Name	Field	Bit	Description
0xF100FFC	GPDATA_INFO	BufferSize	[0..31]	Size of GPDATA_BUFFER (byte) Bit 0 ... bit 254 is reserved for shading correction data (not used) Bit 255 is used for defect pixel correction (only CMOS cameras)
0xF1001000 ... 0xF10017FC	GPDATA_BUFFER			

Table 150: Advanced register: **GPData buffer**

Note



- Read the BufferSize before using.
- GPDATA_BUFFER can be used by only one function at a time.

Little endian vs. big endian byte order

- Read/WriteBlock accesses to GPDATA_BUFFER are recommended, to read or write more than 4 byte data. This increases the transfer speed compared to accessing every single quadlet.
- The big endian byte order of the 1394 bus is unlike the little endian byte order of common Intel PCs. Each quadlet of the local buffer, containing the LUT data for instance, has to be swapped byte-wise from little endian byte order to big endian byte order before writing on the bus.

Bit depth	little endian → big endian	Description
8 bit	L0 L1 L2 L3 ⇒ L3 L2 L1 L0	L: low byte
16 bit	L0 H0 L1 H1 ⇒ H1 L1 H0 L0	H: high byte

Table 151: Swapped first quadlet at address offset 0

Firmware update

Firmware updates can be carried out via FireWire cable without opening the camera.

Note



For further information read the application note:
How to update Guppy/Guppy PRO/Pike/Stingray firmware.

This application note and the firmware itself is only accessible for distributors. End customers have to contact technical support.

Extended version number (FPGA/ μ C)

The new extended version number for microcontroller and FPGA firmware has the following format (4 parts separated by periods; each part consists of two digits):

Special.Major.Minor.Bugfix

or

xx.xx.xx.xx

Digit	Description
1st part: Special	Omitted if zero Indicates customer specific versions (OEM variants). Each customer has its own number.
2nd part: Major	Indicates big changes Old: represented the number before the dot
3rd part: Minor	Indicates small changes Old: represented the number after the dot
4th part: Bugfix	Indicates bugfixing only (no changes of a feature) or build number

Table 152: New version number (microcontroller and FPGA)

Appendix

Sensor position accuracy of AVT Guppy PRO cameras

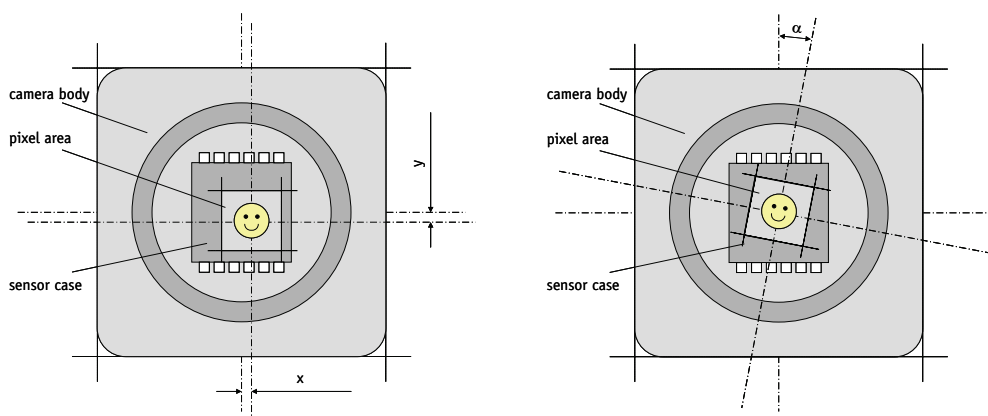

AVT Guppy PRO series

Method of positioning:	Optical alignment of photo sensitive sensor area into camera front module. (lens mount front flange)
Reference points:	Sensor: Center of pixel area (photo sensitive cells). Camera: Center of camera front flange (outer case edges).
Accuracy:	x/y: +/- 150 μm (Sensor shift) z: +0 / -100 μm (Optical back focal length) α: +/- 0.5° (Sensor rotation)

Note: x/y - tolerances between C-Mount hole and pixel area may be higher.



Figure 91: AVT sensor position accuracy

Index

Numbers

0xF1000010 (version info)	238
0xF1000040 (advanced feature inquiry).....	241
0xF1000100 (camera status).....	243
0xF1000200 (max. resolution)	244
0xF1000208 (time base)	244
0xF100020C (extended shutter).....	155, 246
0xF1000210 (test image)	247
0xF1000240 (LUT).....	248
0xF1000298 (DPC_CTRL).....	250
0xF1000300 (input control).....	76
0xF1000340 (Delayed IntEna)	253
0xF1000360 (auto shutter control)	254
0xF1000370 (auto gain control)	255
0xF1000390 (autofunction AOI)	256
0xF10003A0 (color correction).....	257
0xF1000400 (trigger delay)	258
0xF1000410 (mirror image)	258
0xF1000510 (soft reset).....	259
0xF1000550 (user profiles/memory channels/ user sets)	265
0xF1000560 (Max. ISO size S400).....	260
0xF1000564 (Max. ISO size S800).....	260
0xF10005B0 (low- noise binning mode).....	263
0xF10005C0 (global reset release shutter)...	268
0xF1000840 (debounce).....	152
0xF1000FFC (GPData buffer).....	269
1394a data transmission	24
1394b	
bandwidths	29
requirements laptop.....	30
1394b data transmission	25
2 out of 4 H+V sub-sampling (b/w)	
drawing	128
2 out of 4 H+V sub-sampling (color)	
drawing	130
2 out of 8 H+V sub-sampling (b/w)	
drawing	129
2 out of 8 H+V sub-sampling (color)	
drawing	130

A

Abs_Control (Field)	97, 102, 104, 105, 107
---------------------------	------------------------

Abs_Control_Inq (Field)	78
access	
binning and sub-sampling	130
AccessLutNo (Field).....	248
Access_Control_Register	224
accuracy	
sensor position	272
AddrOffset (Field)	248
Advanced feature inquiry	241
Advanced feature inquiry (advanced register)...	241
Advanced features.....	236
activate	238
base address.....	224
inquiry.....	222
advanced register	
Advanced feature inquiry.....	241
Auto gain control.....	255
Auto shutter control.....	254
Autofunction AOI	256
Camera status.....	243
Color correction	257
defect pixel correction	250
Delayed Integration Enable (IntEna)	253
Extended shutter.....	155, 246
Extended version.....	238
Format_7 mode mapping	262
global reset release shutter.....	268
GPData buffer	269
Input control.....	76
low-noise binning mode	263
LUT	248
Max. ISO packet	260
Max. resolution	244
Mirror	258
Mirror image.....	258
Output control.....	82
Soft reset.....	259
Test images	247
Time base.....	244
Trigger delay	258
User profiles.....	265
AOI.....	181
area of interest (AOI)	183

asynchronous broadcast	159	color camera.....	95
auto exposure		block diagrams	
limits	254	cameras	94
target grey level.....	106, 254	BOSS.....	25
Auto Exposure (CSR register)	105	BRIGHTNESS.....	107, 230
auto gain.....	103, 254	Brightness	
Auto gain control (advanced register)	255	inquiry register	223
auto shutter.....	100, 101, 254	brightness	
Auto shutter control (advanced register)	254	auto shutter	101
auto white balance.....	100	average.....	103
external trigger.....	100	decrease	254
AUTOFNC_AOI.....	100, 256	IIDC register.....	107
AUTOFNC_AOI positioning	101	increase	106, 254
Autofunction AOI (advanced register)	256	LUT	109
AUTOGAIN_CTRL.....	255	nonlinear	109
AUTOSHUTTER_CTRL	254	reference	101, 103
AUTOSHUTTER_HI	254	setting	106
AUTOSHUTTER_LO	254	sub-sampling	125
AUTO_EXPOSURE	105	variation	253
Auto_Inq.....	78	Brightness Control	223
AVT sensor position accuracy	272	Brightness (CSR register)	107
A_M_MODE (Field).....	97, 102, 104, 105, 107	BRIGHTNESS_INQUIRY	225
B		Brightness_inq.	225
bandwidth	162	buffer	
affect frame rate	199	LUT	111
available	185	BuildDPData flag.....	115
frame rates.....	184	advanced register	250
RGB8 format	138	bulk trigger.....	141, 146
save in RAW-mode	134	bulk trigger (Trigger_Mode_15).....	146
BAYER demosaicing	134, 136	bus owner supervisor selector (BOSS).....	25
BAYER mosaic.....	134	busy signal	80
BAYER to RGB		Bus_Id	203
color interpretation	134	C	
binning	117	camera dimensions.....	66
access.....	130	2 x 1394b copper	66
full.....	123	camera interfaces.....	70
horizontal	121	camera lenses.....	35
only Guppy PRO b/w	117	Camera status (advanced register)	243
vertical	118	cameras	
BitsPerValue.....	248	block diagram	94
black level	106	CAMERA_STATUS	243
black value	106	Camera_Status_Register	203
black/white camera		CE	22
block diagram	94	channel.....	88
blink codes	73	color camera	
block diagram		block diagram	95
b/w camera	94	color coding.....	133

color codings	133
color correction	136, 137
AVT cameras	136
formula	136
why?	136
Color correction (advanced register)	257
color information	134
Color_Coding	133
COLOR_CODING_INQ	133
common GND	
inputs.....	71
common vcc	
outputs.....	71
continuous	
using Trigger_Mode_15	148
controlling	
image capture.....	139
CSR	203
shutter	102
CSR register	
Auto Exposure.....	105
Brightness.....	107
GAIN	104
D	
data block packet format.....	88
description	88
data exchange buffer	
LUT	111
data packets	88
data path.....	94
data payload size.....	29, 199
data_length	88
DCAM	20, 162, 203
debounce time	
for input ports	152
debounce time for trigger	151
declaration of conformity.....	22
defect pixel correction	
advanced register	250
build and store	114
building defect pixel data.....	114
calculated mean value.....	250
max. 2000 defect pixels.....	251
mechanisms.....	112
defect pixel correction (advanced register)	250
defect pixel correction (DPC)	250
Delayed Integration Enable (IntEna) (advanced register)	253
DelayTime.....	253
Digital Camera Specification (DCAM)	203
digital video information	88
digitizer	110
document history.....	10
DPC (defect pixel correction)	250
DPC_CTRL	250
DPC_INFO	251
DPC_MEM.....	251
DPDataSize	
defect pixel data size (max. 2000)	251
E	
edge mode (Trigger_Mode_0)	80, 141
effective min. exp. time.....	154
electronic rolling shutter (ERS)	140
EnableMemWR (Field)	248
End of exposure.....	158
error code	
user profiles	266
error codes	
LED	74
error states	73
ERS (=electronic rolling shutter)	140
ExpOffset.....	245
Exposure time	
(Field)	155
exposure time	153
81 Ch register.....	155
example	155
extended shutter.....	246
formula.....	153
longest.....	155
long-term integration	155
minimum	155
ExpressCard	
technology	30
ExpTime (Field)	155
EXTD_SHUTTER	246
extended shutter	155
FireDemo.....	246
FireView.....	246
inactive	155, 246
register.....	246
trigger mode	141
Extended shutter (advanced register)	155, 246

- Extended version (advanced register).....238
EXTENDED_SHUTTER..... 153, 155
External GND 71
external trigger 75
- F**
- FCC Class B..... 22
FireDemo
 extended shutter246
FireView
 extended shutter246
FireWire
 connecting capabilities 25
 definition..... 23
 serial bus 24
FireWire 400..... 26
FireWire 800..... 26
firmware update 271, 272
flash140
focal length 35
 Guppy PRO F-031..... 35
 Guppy PRO F-032..... 36
 Guppy PRO F-033/046/146..... 37
 Guppy PRO F-503..... 36
Format_7 mode mapping (advanced register)....
262
Format_7 modes
 mapping132
formula
 color correction.....136
frame rates162
 bandwidth.....184
 bus speed.....162
 Format_7188
 maximum162
 tables.....184
 video mode 0.....187
 video mode 2.....187
Frame valid 80
free-run.....159
full binning.....123
Fval 80
Fval signal 80
- G**
- gain
 auto103
 auto exposure CSR103
 AUTOFNC_AOI100
 manual106
 manual gain range.....106
 ranges106
gain CSR.....106
GAIN (CSR register)104
GAIN (name)104
GAIN (register) 98
gamma function109
gamma LUT109
global reset release shutter (GRR)
 advanced register268
 description140
global shutter139
GPData buffer (advanced register)269
GPDATA_BUFFER111
GRR (global reset release shutter)
 description140
Guppy PRO F-031B/C (Specification) 38
Guppy PRO F-032B/C (Specification) 40
Guppy PRO F-033B/C (Specification) 42
Guppy PRO F-046B/C (Specification) 44, 46
Guppy PRO F-125B/C (Specification) 48
Guppy PRO F-146B (Specification) 50
Guppy PRO F-201B/C (Specification) 52
Guppy PRO F-503B/C (Specification) 54
Guppy PRO F-95C (Specification) 46
Guppy PRO types..... 21
- H**
- hardware trigger79, 150
horizontal binning121
horizontal sub-sampling (b/w)
 drawing125
horizontal sub-sampling (color)
 drawing126
hue.....135
 offset135
- I**
- ID
 color coding133
IEEE 1394..... 20
IEEE 1394 standards..... 23
IEEE 1394 Trade Association.....203
IEEE 1394b connector..... 70

IIDC.....	20, 162, 203	IsoEnable	
data structure	91, 92	white balance	99
isochronous data block packet format....	88	ISO_Enable	159
pixel data.....	88	ISO_Enable mode.....	159
trigger delay.....	78	multi-shot.....	159
video data format.....	89	one-shot.....	156
YUV 4:1:1.....	89, 90	J	
YUV 4:2:2.....	89, 90	jitter.....	158, 160
IIDC V1.31	139	at exposure start.....	161
IIDC V1.31 camera control standards.....	27	L	
image capture		LCD shutter	145
controlling	139	LED	
IMAGE_POSITION	181	error codes	74
IMAGE_SIZE	181	indication	73
input		status.....	72
block diagram	75	Legal notice	2
signals.....	75	level mode (Trigger_Mode_1).....	141
Input control (advanced register).....	76	look-up table (LUT).....	109, 248
input mode	77	user-defined	109
InputMode (Field)	76	low-noise binning mode (advanced register)	263
inputs		LUT.....	248
common GND	71	data exchange buffer	111
general	75	example	109
in detail.....	75	gamma	109
triggers.....	75	general.....	109
input/output pin control.....	252	loading into camera.....	111
inquiry		volatile.....	110
trigger source 0.....	226	LUT (advanced register)	248
Inquiry register		LutNo.....	248
basic function.....	222	LutNo (Field).....	248
Integration Enable signal.....	80	LUT_CTRL.....	248
IntEna.....	71, 84	LUT_INFO	248
IntEna signal	80, 253	LUT_MEM_CTRL.....	248
IntEna_Delay.....	85	M	
IntEna_Out	253	Manual_Inq.....	78
internal trigger.....	141, 146	Maximum resolution (Register)	244
interpolation		MaxLutSize (Field)	248
BAYER demosaicing	134, 135	MaxResolution (Field).....	241
BAYER to RGB	134	MaxSize (Field).....	251
color	134	MaxValue	255
IO_INP_CTRL1	76	MAX_RESOLUTION	244
IO_OUTP_CTRL1	82	Max_Value	78
IO_OUTP_CTRL2	82	Max. ISO packet (advanced register)	260
IO_OUTP_CTRL3	82		
isochronous blocks	88		
isochronous channel number	88		
isochronous data block packet format	88		
isochronous data packets	88		
Isochronous Resource Manager (IRM).....	261		

Max. resolution (advanced register)	244	ON_OFF	78
Mean		ON_OFF (Field)	97
defect pixel mean value.....	250	optocoupler	75
mechanical shutter.....	145	output	
memory channels	265	block diagram	81
memory channels (user profiles).....	265	signals.....	80
Micron/Aptina CMOS sensor	140	Output control (advanced register)	82
minimum exposure time	154	output impulse diagram	
MinValue	255	WaitingForTrigger	84
Min_Value.....	78	output mode	82
Min. exp. time + offset	154	ID	83
Mirror image (advanced register).....	258	Output mode (Field)	82
Mirror (advanced register)	258	output pin control	83
MSB aligned	88	outputs	80
multi-shot	159	common vcc	71
external trigger	159	general	75
using Trigger_Mode_15	148	registers	82
		set by software	85
		OutVCC	71
N			
Node_Id	203	P	
NumOfLuts	248	Packed 12-Bit Mode	133
NumOfLuts (Field)	248	Packed 12-Bit MONO.....	133
		Packed 12-Bit RAW.....	133
O		packet format.....	88
OFFSET		PI controller	103
automatic white balance	98	pin control.....	252
offset.....	153	PinState flag	82
800h	107	PinState (Field)	76
CCD	106	pixel data	88
configuration ROM.....	208	plus integral controller	103
factors	208	Polarity (Field)	76, 82
hue	135	Power	
initialize register.....	211	IEEE 1394b.....	70
inquiry register video format.....	211	power	
inquiry register video mode.....	212	GND	71
saturation	135	presence	
setting brightness	106	trigger source 0	226
setting gain.....	106	Presence_Inq	76
one-push white balance	98, 99	Presence_Inq (Field)	78, 97
one-shot.....	156	programmable mode (Trigger_Mode_15)	141
Trigger_Mode_15.....	141, 146	pulse-width modulation	
using Trigger_Mode_15	148	signal.....	80
values.....	157	PulseWidthMod signal.....	80
one-shot bit.....	156		
one-shot mode	156	R	
One_Push (Field)	97, 102, 104, 105, 107	read value	
One_Push_Inq	78		

trigger input.....	226	Guppy PRO F-503C	65
Readout_Inq	78	spectral transmission	
RGB to YUV		Hoya C5000	34
formula	138	IR cut filter	34
RGB8 format.....	138	standard housing	66
RoHS (2002/95/EC)	22	status LED	72
row time		stored settings	
Guppy PRO F-503	153	user profile.....	267
S		styles	18
saturation	135	sub-sampling	
offset	135	access	130
sensor position accuracy	272	brightness.....	125
sequence		b/w and color	125
loading a LUT	111	definition.....	125
one-push white balance.....	99	sy (sync bit)	88
OneShot.....	156	symbols.....	18
SHUTTER.....	102	sync bit (sy)	88
Shutter CSR.....	102	synchronization value (sync bit)	88
shutter time		system components.....	34
formula	153	T	
SHUTTER_MODES.....	139	tag field	88
signal-to noise ratio (SNR)		target grey level	
vertical binning.....	119	corresponds to Auto_exposure.....	231
signal-to-noise ratio (SNR).....	117	Target grey level (auto exposure)	106, 254
signal-to-noise separation.....	117	Target grey level (SmartView)	
SNR	117	corresponds to auto exposure.....	101
Soft reset (advanced register)	259	tCode	88
software trigger	151	test image	201
Software_Trigger (CSR)	228	Bayer-coded	202
specifications	38	b/w cameras.....	201
spectral sensitivity		color	202
Guppy PRO F-031B	57	color cameras	202
Guppy PRO F-031C	57	configuration register	247
Guppy PRO F-032B	58	grey bar	201
Guppy PRO F-032C	58	save	247
Guppy PRO F-033B	59	Test images (advanced register)	247
Guppy PRO F-033C	59	TEST_IMAGE	247
Guppy PRO F-046B	60	tg.....	88
Guppy PRO F-046C	60	threshold	
Guppy PRO F-095C	61	defect pixel correction	115, 250
Guppy PRO F-125B	62	time base	155
Guppy PRO F-125C	62	exposure time.....	153
Guppy PRO F-146B	63	setting	246
Guppy PRO F-146C	63	trigger delay.....	78, 149
Guppy PRO F-201B	64	time base ID	245
Guppy PRO F-201C	64	Time base (advanced register)	244
Guppy PRO F-503B	65	time base (Register).....	244

time response.....	157	TRIGGER_DELAY	79, 150
TIMEBASE	236, 244	TRIGGER_DELAY_INQUIRY.....	78, 149
TimeBase (Field)	241	TRIGGER_MODE	147
TPA-		Trigger_Mode	147
IEEE 1394b.....	70	Trigger_Mode_0 Guppy PRO F-503	
TPA(R)		electronic rolling shutter.....	143, 144
IEEE 1394b.....	70	global reset release shutter.....	145
TPA+	70	Trigger_Mode_0 (edge mode)	80, 141
TPB-		Trigger_Mode_1 (level mode).....	141
IEEE-1394b.....	70	Trigger_Mode_15 (bulk trigger).....	141, 146
TPB(R)		Trigger_Mode_15 (programmable mode)	141
IEEE 1394b.....	70	Trigger_Polarity	147
TPB+	70	Trigger_Source	147
IEEE 1394b.....	70	Trigger_Source0_Inq	226
transaction code (tCode).....	88	Trigger_Value	147
trigger		tripod adapter	67
bulk	141, 146	tripod dimensions.....	67
control image capture	139	types	
delay	78, 85	Guppy PRO cameras	21
edge.....	79		
external	139	U	
hardware	79, 150	UNIT_POSITION_INQ.....	181
impulse.....	156	UNIT_SIZE_INQ.....	181
IntEna	84	user profile	
internal	141, 146	stored settings.....	267
latency time	160	user profiles	265
microcontroller	157	error code	266
one-shot	156	User profiles (advanced register).....	265
signal	75	user sets.....	265
software.....	159	U/B_Value (Field)	97
synchronize	160	U/V slider range	98
trigger delay	149		
advanced CSR.....	79, 150	V	
advanced register	79, 150	VCC	
off	79	IEEE 1394b.....	70
on.....	79	Vendor Unique Color_Coding.....	133
Trigger Delay CSR.....	79	Vendor unique Features.....	222
trigger delay CSR	150	vertical binning	118
Trigger delay inquiry register	149	SNR.....	119
trigger delay inquiry register	78	vertical sub-sampling (b/w)	
Trigger delay (advanced register)	258	drawing	127
trigger function	147	vertical sub-sampling (color)	
trigger input		drawing	128
read raw data.....	226	VG (GND)	
trigger modes.....	141	IEEE 1394b.....	70
trigger source 0		video data format	
inquiry.....	226	IIDC V1.31	89
triggers	75		
input.....	75		

Video data payload.....	88
video format	
available bandwidth.....	184
frame rate	184
video formats	162
Guppy F-503	179
video Format_7	
AOI	181
video information	88
video mode	
CUR-V-MODE	228
Format_7	234
inquiry register	212
sample C code.....	206
video mode 0	187
video mode 2	187
VP	
IEEE 1394b.....	70
VP (Power, VCC)	
IEEE 1394b.....	70
V/R_Value (Field).....	97

W

WaitingForTrigger	
ID 0x0A	83
output impulse diagram.....	84
WaitingForTrigger signal	80
white balance	
auto	100
auto shutter	101
AUTOFNC_AOI	100
conditions.....	99, 100
general	96
one-push.....	98, 99
register 80Ch	97
six frames	98
WHITE_BALANCE	97, 99
www.alliedvisiontec.com	20, 21