



GigE VISION CAMERAS

Mako G

Technical Manual

V4.4.2

Mako G at a glance



Read this manual carefully

Learn how to protect your camera from damage and fully understand its functions.

Mako G is Allied Vision's ultra-compact format AIA GigE Vision compliant camera. Mako G models incorporate high quality CCD or CMOS sensors from Sony, ON Semiconductor, Teledyne e2v, and CMOSIS/ams.

Mako G cameras are offered with either a C-Mount or CS-Mount to support a wide range of lenses. An M12-Mount (S-Mount) adapter is also available.

Scope of delivery

Your Allied Vision camera is delivered with the following components:

- Mako G GigE Vision camera
- Quickstart Guide
- Camera box.

What else do you need?

Content	URL
GigE Features Reference, Camera data sheets, Modular Concept, and 3D CAD STEP files	www.alliedvision.com/en/support/technical-documentation/mako-g-documentation.html
Technical papers and knowledge base	www.alliedvision.com/en/support/technical-papers-knowledge-base.html
Camera lenses and accessories	www.alliedvision.com/en/products/accessories.html
Download Vimba and software tools	www.alliedvision.com/en/support/software-downloads.html
Download the latest GigE firmware loader and release notes.	www.alliedvision.com/en/support/firmware
For details about camera warranty duration and sensor warranty terms.	www.alliedvision.com/en/support/warranty

Table 1: Additional resources

Contact us

Connect with Allied Vision by function

www.alliedvision.com/en/meta-header/contact

Find an Allied Vision office or distributor

www.alliedvision.com/en/about-us/where-we-are

General inquiries

info@alliedvision.com

Technical support

support@alliedvision.com

Sales offices

Europe, Middle East, and Africa: +49 36428 677-0

North, Central, and South America: +1 (877) USA-1394

Asia-Pacific: +65 6634-9027

China: +86 (21) 64861133

Headquarters

Allied Vision Technologies GmbH

Taschenweg 2a

07646 Stadtroda, Germany

Tel: +49 36428 677-0

Fax: +49 36428 677-28

CEO/Geschäftsführer: Andreas Gerke

Registration Office: AG Jena HRB 208962

Contents

Mako G at a glance	2
Scope of delivery	2
What else do you need?	2
Contact us	3
Document history and conventions	8
Document history	9
Manual conventions	13
Styles	13
Symbols and notes	14
Product naming	14
Abbreviations and acronyms	15
Compliance and intended use	16
Compliance notifications	17
For customers in Europe	17
For customers in the U.S.	17
Supplier Declaration of Conformity	17
For customers in Canada	18
Pour utilisateurs au Canada	18
Avoid electromagnetic interferences	18
Camera applications and intended use	19
General use	19
Use in medical devices	19
Copyright and trademarks	20
Installation and hardware	21
Precautions	22
Electrical connections	22
Optical components	23
Mounting the camera	24
Configuring the host computer	24
Installing the network interface card driver	25
Optional: Modifying network interface card IP address	25
Network interface card driver settings	25
Enabling jumbo packets	26
Connecting your camera	27
Optics	27
Accessories	27
Software	28
Powering up the camera	28
Powering the camera via Hirose I/O port	28
Powering the camera via PoE	28
Connecting to host application	29

Allied Vision software	29
Third-party software	29
Specifications	30
Applied standards	31
Shock and vibration	31
Notes on specifications	31
Dimensions and mass	31
Frame memory	32
Resolution and ROI frame rate	32
Absolute QE plots	33
Spectral response plots	34
Specifications common to all models	34
Mako G-030 series	35
Absolute QE	36
ROI frame rate	37
Mako G-032 series	38
Absolute QE	40
Spectral response	40
ROI frame rate	41
Mako G-040 series	42
Absolute QE	44
Spectral response	44
ROI frame rate	45
Mako G-125 series	46
Absolute QE	48
Spectral response	48
ROI frame rate	49
Mako G-131 series	50
Absolute QE	52
ROI frame rate	53
Mako G-158 series	54
Absolute QE	56
Spectral response	56
ROI frame rate	57
Mako G-192 series	58
Absolute QE	60
ROI frame rate	61
Mako G-223 series	62
Absolute QE	63
ROI frame rate	64
Mako G-234 series	65
Absolute QE	67
Spectral response	67
ROI frame rate	68
12-bit sensor readout	68
10-bit sensor readout	69
Mako G-319 series	70
Absolute QE	72

Spectral response	72
ROI frame rate	73
Mako G-419 series	74
Absolute QE	75
ROI frame rate	76
Mako G-503 series	77
Absolute QE	78
ROI frame rate	79
Mako G-507 series	80
Absolute QE	82
Spectral response	82
ROI frame rate	83
Mako G-508B POL	84
Absolute QE	85
Polarization coding diagram	86
ROI frame rate	86
Camera feature comparison	88
Mechanical dimensions	90
C-Mount (default)	90
CS-Mount	90
M12-Mount (S-Mount)	91
Tripod adapter	91
Sensor position accuracy	92
Lens mount cross section	93
C-Mount with 22 mm filter (default)	93
CS-Mount with 22 mm filter	94
M12-Mount (S-Mount) with 22 mm filter	94
C-Mount with 16 mm filter	94
CS-Mount with 16 mm filter	95
M12-Mount (S-Mount) with 16 mm filter	95
Dimensional adjustment	95
Filter and lenses	96
Camera lenses	97
Mako G-030 series	97
Mako G-032 series	98
Mako G-040 series	98
Mako G-131 series	99
Mako G-158 series	99
Mako G-192 series	100
Mako G-223 series	100
Mako G-234 series	101
Mako G-319 series	101
Mako G-419 series	102
Mako G-503 series	102
Mako G-507 series	103
Mako G-508B POL	103
IR cut filter	104

Camera interfaces	105
Back panel	106
Status LEDs	106
Gigabit Ethernet port	107
Camera I/O connections	107
Input block diagram	109
Output block diagram	110
Control signals	112
Input block diagram	112
Output signals	112
Camera trigger	114
Trigger timing diagram	114
Trigger definitions	115
Trigger rules	115
Triggering during the idle state	116
Triggering during the readout state	116
Image data flow	117
Mako G model series with CCD sensors	118
Mako G-032 and G-125 series	118
Mako G model series with CMOS sensors	119
Mako G-030 series	119
Mako G-131 and G-192 series	120
Mako G-223 and G-419 series	121
Mako G-040, G-158, G-234, G-319, G-507 series and G-508B POL	122
Mako G-503 series	123
Color interpolation (Bayer demosaicing)	124
Cleaning optical components	126
Keeping optical components clean	127
Identifying impurities	128
Locating impurities	128
Removing the IR cut filter	129
Materials for cleaning optical components	130
Cleaning Instructions	131
Cleaning with compressed air	132
Firmware update	133
Index	138

Document history and conventions



This chapter includes:

- Document history
- Layout styles and symbols used in this manual
- Product naming
- Abbreviations and acronyms used in this manual

Document history

Version	Date	Remarks
V4.4.2	2019-Mar-08	<ul style="list-style-type: none"> Initial commercial release: Mako G-508B POL <ul style="list-style-type: none"> - Sony IMX250MZR CMOS sensor - Specifications, chief ray angle, absolute QE, ROI frame rate Added shock and vibration information Added color interpolation content to Image Data Flow chapter Editorial changes
V4.4.1	2019-Jan-31	<ul style="list-style-type: none"> IEEE 1588 Precision Time Protocol (PTP) and Trigger over Ethernet (ToE) Action Commands features are added to Mako G-040, G-158, G-234, G-319, and G-507 series with firmware version 01.54.21000 Updated Mako G-040, G-158, G-234, G-319, and G-507 series specifications (firmware version 01.54.21000), see the GigE Firmware Release Notes for details of the changes Added trigger latency and trigger jitter values for Mako G-223 and G-419 series Corrected Mako G-040 series streamhold capacity value Added content to installation chapter: Powering the camera via PoE Corrected Mako G 2D technical drawings Corrected lens mount cross section drawings Added Mounting the camera to Hardware and Installation chapter Added Supplier Declaration of Conformity to Compliance and intended use chapter Added camera electronics damage notice table to Installation and hardware chapter Various other minor enhancements and corrections
V4.4.0	2018-Jul-11	<ul style="list-style-type: none"> Initial commercial release: Mako G-040 series <ul style="list-style-type: none"> - Sony IMX287 CMOS sensor - Specifications, chief ray angle, absolute QE, spectral response, ROI frame rate Initial commercial release: Mako G-158 series <ul style="list-style-type: none"> - Sony IMX273 CMOS sensor - Specifications, chief ray angle, absolute QE, spectral response, ROI frame rate Updated installation chapter Updated symbols used in this manual Updated RoHS statement to include amendment 2015/863/EU Added abbreviations and acronyms used in this manual Various other minor enhancements and corrections

Table 2: Document history (sheet 1 of 5)

Version	Date	Remarks
V4.3.3	2017-Dec-11	<ul style="list-style-type: none"> Added Removing IR cut filter section to cleaning chapter Added Specifications common to all models to simplify the model specific tables Simplified the Contact us section, click the link to find contact information for your region or email us at one of the provided email addresses Various other minor enhancements and corrections
V4.3.2	2017-Jul-31	<ul style="list-style-type: none"> Mako G-223 and G-419 series: Removed RGBA8Packed and BGRA8Packed pixel formats Mako G-234 series: Added Mono12 and Mono12Packed Corrected user trigger pulse statement Updated camera images to reflect the new black powder coating housing. For more information, see PCN-2017-03-05 CMOSIS renamed to CMOSIS/ams following the acquisition of CMOSIS by ams Sensors Belgium e2v renamed to Teledyne e2v following the acquisition of e2v by Teledyne Technologies Inc. Corrected user trigger rules Corrected exposure control values for Mako G-223 series Updated technical drawing Updated camera dimensions in specification tables Changed cell size terminology to pixel size
V4.3.1	2017-Apr-07	<ul style="list-style-type: none"> Added cable color to camera I/O connector pin assignment including pin assignment figure and cross reference to the Allied Vision I/O cable data sheet
V4.3.0	2017-Mar-13	<ul style="list-style-type: none"> Added Piecewise Linear HDR option to Exposure Mode for the Mako G-223 and G-419 series. For more information, see the GigE Features Reference. Various minor corrections
V4.2.3	2016-Dec-21	<ul style="list-style-type: none"> Added missing absolute QE plots for NIR wavelength (Mako G-223B NIR and Mako G-419B NIR)
V4.2.2	2016-Nov-23	<ul style="list-style-type: none"> BinningHorizontalMode and BinningVerticalMode options Sum and Average are supported by Mako G-131, G-192, and G-503 series Updated the absolute QE plot and added a spectral response plot for the Mako G-032
V4.2.1	2016-Nov-08	<ul style="list-style-type: none"> Corrected typographic issues Corrected Mako G-503 shutter type
V4.2.0	2016-Nov-07	<ul style="list-style-type: none"> Initial commercial release: Mako G-319 series <ul style="list-style-type: none"> Sony IMX265 CMOS sensor Specifications, absolute QE, spectral response, ROI frame rate information, camera lens information, and image data flow Added missing information in specification tables

Table 2: Document history (sheet 2 of 5)

Version	Date	Remarks
V4.1.0	2016-Oct-12	<ul style="list-style-type: none"> Initial commercial release: Mako G-507 series <ul style="list-style-type: none"> Sony IMX264 CMOS sensor Specifications, absolute QE, spectral response, ROI frame rate information, camera lens information, and image data flow Added a tripod adapter warning message Updated absolute QE plots for models with Sony sensors Added spectral response plots for models with Sony sensors Added optical filter information to specification tables Added overlapping trigger note for Mako G-131 and G-192 in Specifications chapter and Camera interfaces chapter Updated image flow diagrams Updated Mako G-234 series specifications Added 10-bit, 12-bit switchability to Mako G-234 series
V4.0.0	2015-Nov-24	<ul style="list-style-type: none"> Changed the technical manual layout Changed chapter name from Camera data path to Image data flow Changed chapter name from Camera dimensions to Mechanical dimensions Merged the Resolution and ROI frame rate chapter of V3.2.0 into Specifications chapter Added Mako G at a glance section Added General safety notes section Added Regulations section in Safety and regulations chapter to replace Legal notice and Safety and regulations sections in V3.2.0 Moved Sensor position accuracy section from Appendix to Mechanical dimensions chapter Deleted Appendix Added Camera feature comparison section in Specifications chapter to replace Camera smart features and Camera features sections in V3.2.0 Added Cross section: C-Mount and CS-Mount section to replace Cross section: <ul style="list-style-type: none"> C-Mount and Cross section: CS-Mount sections in V3.2.0 Added Cleaning optical components chapter to replace Camera cleaning section of V3.2.0 Added Contact us section to replace Contacting Allied Vision section of V3.2.0
V4.0.0	2015-Nov-24	<ul style="list-style-type: none"> Initial commercial release: Mako G-234 series <ul style="list-style-type: none"> Sony IMX249 CMOS sensor Specifications, absolute QE, spectral response, ROI frame rate information, camera lens information, and image data flow Removed references to Mako G-050 and G-095 series. The last time shipment period ends on December 31, 2015 as detailed in PCN 2015-05-03. Updated Camera Interfaces chapter

Table 2: Document history (sheet 3 of 5)

Version	Date	Remarks
V3.2.0	2015-Mar-20	<ul style="list-style-type: none"> Replaced old links with new Allied Vision website links Changed file name from GigE Camera and Driver Features to GigE Features Reference
V3.1.0	2015-Mar-10	<ul style="list-style-type: none"> Initial commercial release: Mako G-503 series <ul style="list-style-type: none"> ON Semi MT9P031/MT9P006 CMOS sensor Specifications, absolute QE, ROI frame rate information, camera lens information, and image data flow Added camera lens information Added ROI frame rate section Updated Image data flow and Mechanical dimensions chapters
V3.0.0	2015-Jan-15	<ul style="list-style-type: none"> Initial commercial release: Mako G-030 series <ul style="list-style-type: none"> CMOSIS/ams CMV300 CMOS sensor Specifications, absolute QE, ROI frame rate information, camera lens information, and image data flow Initial commercial release: Mako G-131 series <ul style="list-style-type: none"> Teledyne e2v EV76C560 CMOS sensor Specifications, absolute QE, ROI frame rate information, camera lens information, and image data flow Initial commercial release: Mako G-192 series <ul style="list-style-type: none"> Teledyne e2v EV76C570 CMOS sensor Specifications, absolute QE, ROI frame rate information, camera lens information, and image data flow Updated Allied Vision logo Updated Cleaning optical components chapter Updated Mako G camera smart features table Added camera lens information Added ROI frame rate, ROI frame rate, and ROI frame rate sections Updated Image data flow and Mechanical dimensions chapters
V2.1.0	2014-Oct-07	<ul style="list-style-type: none"> Updated and rearranged Notes on specifications section Added Camera features comparison Added trigger latency and jitter values for Mako G-032 and G-125 series Updated Mako G standard housing drawing Updated Mako G-503C section Added camera lens information Updated image data flow and mechanical dimensions chapters
V2.0.4	2014-Feb-28	<ul style="list-style-type: none"> Updated available color pixel formats for Mako G-223 and G-419 series Updated optional accessories in the Notes on specifications section Updated section Cross section: C-Mount and CS-Mount Added section Heat dissipation Updated the operating temperature specification for Mako G-032, G-125, G-223, and G-419 series Updated block diagrams in Image data flow to remove the RS232 reference Added Hirose cable information

Table 2: Document history (sheet 4 of 5)

Version	Date	Remarks
V2.0.3	2013-Nov-27	<ul style="list-style-type: none"> Updated gain control values for Mako G-223 and G-419 series Updated Status LED 2 table Updated the note on StreamHoldCapacity in Notes on specifications and frame memory sections Updated block diagrams in Image data flow chapter Updated the Index
V2.0.2	2013-Sep-16	<ul style="list-style-type: none"> Updated the frame rate information for Mako G-223 and G-419 series in the Specifications chapter Updated introduction to include link to Mako G documentation webpage Updated Status LEDs section Added captions to tables in camera lenses section Added links to GigE Camera and Driver Features document
V2.0.1	2013-Sep-11	<ul style="list-style-type: none"> Added table of contents Added camera cleaning chapter Updated the specifications for Mako G-223 and G-419 series
V2.0.0	2013-Aug-30	<ul style="list-style-type: none"> New manual release status

Table 2: Document history (sheet 5 of 5)

Manual conventions

To give this manual an easily understood layout and to emphasize important information, the following typographical styles and symbols that are used.

Styles

Style (example)	Function
Emphasis	Some important parts or items of the text are emphasized to make them more visible.
Feature names	GigE features names are displayed as monospaced text.
Feature options	Features options and register's options that are selectable by the user are displayed as monospaced italicized text.
UI Element	Text that is displayed, or output, by the system for the user, like parts of the GUI, dialog boxes, buttons, menus, important information, windows titles.
Web Reference	References to other documents or webpages, like web links, hypertext links, emails, but also cross references, that include a link the user can follow by clicking.

Table 3: Markup conventions used in this manual

Symbols and notes



NOTICE

Property damage message

This symbol addresses important information to avoid material damage; however, is not related to physical injury.



NOTICE

Material damage by electrostatic discharge (ESD)

Precautions as described.



CAUTION

Safety message

Note to prevent physical injury.



Safety-related instructions to avoid malfunctions

This symbol indicates important or specific instructions or procedures that are related to product safety. You have to follow these instructions to avoid malfunctions.



Practical hint

This symbol highlights a practical hint that helps to better understand the camera's features and functions, and to make better use of it.



Further information available online

This symbol highlights URLs for further information. The URL itself is shown in blue.
Example:

www.alliedvision.com

Product naming

Names of third-party products in this document are shortened to ease reading. Nevertheless, we respect all manufacturer rights and trademarks.

Official product name	Naming in this document	Manufacturer website
Sony Semiconductor Solutions	Sony	www.sony-semicon.co.jp/
ON Semiconductor	ON Semi	www.onsemi.com/

Table 4: Third-party product naming (sheet 1 of 2)

Official product name	Naming in this document	Manufacturer website
ams Sensors Belgium	CMOSIS/ams	www.cmosis.com/
Teledyne e2v	Teledyne e2v	www.e2v.com/

Table 4: Third-party product naming (sheet 2 of 2)

Abbreviations and acronyms

The following table provides a list of abbreviations and acronyms used in this manual.

Abbreviation or Acronym	Description
ADC	Analog to Digital Converter
AIA	Automated Imaging Association
CCD	Charge-coupled device
CMOS	Complementary metal-oxide semiconductor
EMI	Electromagnetic Interference
EMVA	European Machine Vision Association
FIFO	First-in first-out
GigE	Gigabit Ethernet
GND	Ground (power)
GVSP	GigE Vision Streaming Protocol
H × V	Horizontal × Vertical (sensor resolution measurement)
LUT	Look-up table
MSDS	Material Safety Data Sheet
NIR	Near-Infrared
PoE	Power over Ethernet
QE	Quantum efficiency
RoHS	Restriction of Hazardous Substances Directive
ROI	Region of interest
SDK	Software Development Kit
SFNC	Standard Feature Naming Convention
t_{pdHL}	Propagation delay high-to-low

Table 5: Abbreviations and acronyms used in this manual

Compliance and intended use



This chapter includes:

- Compliance notifications for the following areas:
 - Europe (CE)
 - U.S. (FCC)
 - Canada (ICES)
- Information about application and intended use of the camera
- Copyright and trademark statement

Compliance notifications

For customers in Europe



Allied Vision has demonstrated the fulfillment of the requirements relating to the Mako G camera family:

- Directive 2014/30/EU (Electromagnetic compatibility)
- Directive 2011/65/EU, including amendment 2015/863/EU (RoHS)

For customers in the U.S.

Supplier Declaration of Conformity

Mako G GigE cameras comply with Part 15 of the FCC Rules. Operation is subject to the following two conditions:

1. This device may not cause harmful interference, and
2. This device must accept any interference received, including interference that may cause undesired operation.

Responsible Party – U.S. Contact Information

Allied Vision Technologies, Inc.
102 Pickering Way – Suite 502
Exton, PA 19341
USA

T// +1 (978) 225-2030



Class B digital device

Note: This equipment has been tested and found to comply with the limits for a Class B digital device, pursuant to part 15 of the FCC Rules. These limits are designed to provide reasonable protection against harmful interference in a residential installation. This equipment generates, uses and can radiate radio frequency energy and, if not installed and used in accordance with the instructions, may cause harmful interference to radio communications. However, there is no guarantee that interference does not occur in a particular installation. If this equipment does cause harmful interference to radio or television reception, which can be determined by turning the equipment off and on, the user is encouraged to try to correct the interference by one or more of the following measures:

- Reorient or relocate the receiving antenna.
- Increase the separation between the equipment and receiver.
- Connect the equipment into an outlet on a circuit different from that to which the receiver is connected.
- Consult the dealer or an experienced radio/TV technician for help.

We caution the user that changes or modifications not expressly approved by the party responsible for compliance could void the user's authority to operate the equipment.

For customers in Canada

This apparatus complies with the Class A limits for radio noise emissions set out in the Radio Interference Regulations.

CAN ICES-3 (A) / NMB-3 (A)

Pour utilisateurs au Canada

Cet appareil est conforme aux normes classe A pour bruits radioélectriques, spécifiées dans le Règlement sur le brouillage radioélectrique.

CAN ICES-3 (A) / NMB-3 (A)

Avoid electromagnetic interferences

For all power and interface connections, only use shielded cables or cables recommended by Allied Vision.

Camera applications and intended use

General use

- The user is responsible for operating the camera within the specifications that are defined in this document, and within appropriate environmental conditions and technical prerequisites, to ensure trouble-free camera operation.
- The camera is compliant with current data communication standards; however, those standards do not allow for self-monitoring. Thus, the camera cannot be used as a standalone device for security-related monitoring operations.
- The camera is a hardware product. Only when used with appropriate accompanying software, the camera produce the desired results. The realization of intelligent solutions requires additional software that is suitable to run with the camera.
- The camera is a component, it is neither a complete product, nor is it a ready-made technical solution.
- The camera-supporting software can be obtained and installed separately from the camera. Usage of the software is solely the responsibility of the user.
- The camera must not be opened. For all repair tasks, contact Allied Vision or one of Allied Vision's authorized representatives.
- Observe the intended use. The camera must only be used for purposes that are in conformity with the stated intended use.
- Additionally, refer to the warranty information on the Allied Vision website.
- For usage in product with specific safety requirements a Quality Assurance Agreement with Allied Vision is required.
- The camera is intended for use in a commercial, industrial, or business environment. The test phase and programming should be carried out by advanced users.

Use in medical devices

The camera provides basic adequacy to be used in medical devices as well, however, is not specially designated for operation in medical devices. When used as part of a medical device, a review of the specific application is necessary. For usage in medical product, a Quality Assurance Agreement with Allied Vision is required. Users who integrate the camera into an application must comply with the rules and regulations concerning medical devices.

Copyright and trademarks

All text, pictures, and graphics are protected by copyright and other laws protecting intellectual property. All content is subject to change without notice.

All trademarks, logos, and brands cited in this document are property and/or copyright material of their respective owners. Use of these trademarks, logos, and brands does not imply endorsement.

Copyright © 2019 Allied Vision GmbH. All rights reserved.

Installation and hardware



This chapter describes the components required for your vision system including configuring the host computer, network interface card settings, and connecting your Mako G camera.

Precautions

Electrical connections



NOTICE

ESD is dangerous for electronic devices, especially when tools or hands get in contact with connectors. We recommend measures to avoid damage by ESD:

- Unpacking: Remove the camera from its anti-static packaging only when your body is grounded.
- Workplace: Use a static-safe workplace with static-dissipative mat and air ionization.
- Wrist strap: Wear a static-dissipative wrist strap to ground your body.
- Clothing: Wear ESD-protective clothing. Keep components away from your body and clothing. Even if you are wearing a wrist strap, your body is grounded but your clothes are not.



NOTICE

Do not operate the camera beyond the environmental specifications. See the environmental specifications limits in the Specifications section of this document. Special care must be taken to maintain operating temperature as specified in the Specifications chapter.



NOTICE

Avoid damage to the camera from high output current or voltage:

- Connecting the camera to a device exceeding the allowed maximum current (20 mA per output) can damage the camera.
- Providing Isolated Out Power > 30 Volts may damage the camera.



NOTICE

Verify all external connections in terms of voltage levels, power requirements, voltage polarity, and signal integrity prior to powering the device.

**NOTICE**

Operation outside the allowed temperature range can damage the camera. For best performance and to protect the camera from damage, keep the housing temperature in the specified operating temperature range. Housing temperature of the camera increases during power-up and initial operation. This temperature later stabilizes.

Observe the following:

- For maximum heat dissipation, affix the camera to a heat sink, using the mounting threads.
 - Use mounting base and heat sink with large surface areas.
 - Use a mounting base with a high thermal conductivity.
- Reduce ambient temperature. For example, in an outdoor application with direct sunlight, provide shading by an enclosure.
- Provide ventilation or other active cooling of camera, mounting base, and heat sink.

Optical components

**NOTICE**

Image sensors are sensitive to excessive radiation: focused sunlight, lasers, and X-rays can damage the sensor. Monochrome and NIR models are not fitted with filter or protection glass. Consider, when removing the lens or dust cap on these cameras, the sensor is not protected against dirt or scratches.

**NOTICE**

Some cleaning agents can damage this product. Avoid cleaning the image sensor unless absolutely necessary. See the instructions on optics cleaning in this document.

We can clean your camera as a service for you, if necessary. For more information, contact Allied Vision support.

**NOTICE**

Provide the following conditions to keep dirt and droplets out of the optical system of camera and lens:

- Dust-free environment
- Low relative humidity
- No condensation

To keep dirt out of the lens mount, hold the camera with the lens mount facing the ground. Keep filter and camera back lens clean, because dirt becomes more visible the closer it gets to the sensor.

NOTICE

As monochrome and NIR models do not have an optical filter, always attach a dust cap when a lens is not attached to minimize the possibility of contaminants falling on the sensor surface.

Mounting the camera

You can attach the camera to a base using the M3 and M2 mounting threads built into the top and bottom of the Mako G camera housing. Optionally, you can use the tripod adapter to mount your Mako G camera to a tripod.

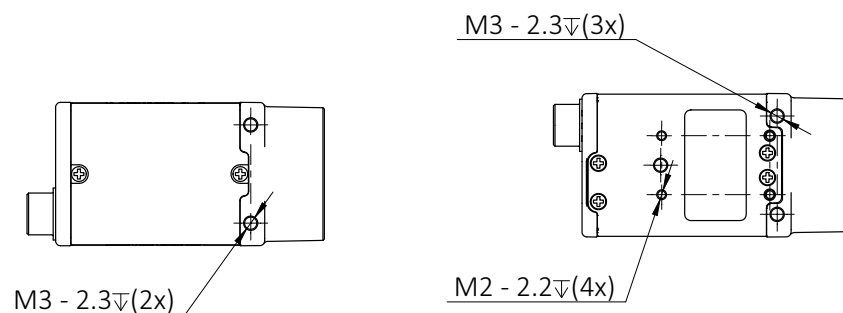

Figure 1: Mounting threads on top and bottom of housing

Configuring the host computer

Mako G cameras can operate on 10/100 or Gigabit speed network interface cards. In order to reach the maximum camera frame rate, a Gigabit speed network interface card with jumbo packet support is required.

If your host computer has an available Ethernet port, this can be used with Mako G cameras. We recommend that your camera system uses a dedicated Ethernet port not shared with Internet or local area networks. If more ports are needed, or your existing network interface card is unable to operate at Gigabit Ethernet speeds, installing additional hardware may be required.

Usage on mixed-use networks (with printers, Internet and email) is possible but may impact camera performance (for example, framerate). Check with your network administrator if required for network configuration.

Installing the network interface card driver

Install the network card driver from your network card manufacturer. If no installation application is provided, update the driver manually.

To update the driver manually

1. Click the **Start** icon and select **Control Panel** in the menu.
2. Click **View by Large Icons** and select **Device Manager** in the list.
3. Under **Network Adapters**, locate the Ethernet network adapter, right-click the entry, and select **Update Driver Software** in the menu.
4. Select the **Search automatically for updated driver software or Browse my computer for driver software**.
5. Click **Close** after the driver has been installed.

Optional: Modifying network interface card IP address

After initial network interface card hardware installation, connect the network interface card directly to the camera. The default configuration assigns an IP address automatically using the Link-Local Address range of 169.254.xxx.xxx or an address defined by the DHCP server, if present.

Users can fix the network interface card address to minimize the time required for a camera to be recognized by the host application. When systems employ multiple network interface cards connected to multiple cameras the address of the network interface cards should be set.

To connect to the camera, edit the host computer's adapter settings and configure the following settings:

- IP Address: 169.254.100.1
- Subnet mask: 255.255.0.0
- Default gateway: blank

Network interface card driver settings

The network interface card should be adjusted to improve system performance when using a Mako G camera. This performance is related to minimizing CPU usage and dropped or resent packets.

Edit the network interface card driver properties according to the values in the following table. The names and availability of the properties listed may vary depending on network interface card manufacturer and model.

Property	Value
Packet size or maximum transmission unit	8228 bytes or larger
Interrupt moderation	Enable
Interrupt moderation rate	Extreme
Receive buffers	Maximum value configurable
Transmit buffers	256 bytes

Table 6: Network interface card settings

Default packet size

The default packet size of Mako G cameras is 8228 bytes. The host network interface card needs to support a packet size of equal or larger size to stream from the camera.

Network interface cards

The network interface card settings may also vary depending on your system configuration and the network interface card manufacturer.

For desktop systems, use a PCI Express bus network interface card. For laptops, use an expansion slot via an ExpressCard®.

A list of recommended network interface cards is available on the Allied Vision website. See the Hardware Selection for Allied Vision GigE Cameras application note.

Enabling jumbo packets

The properties listed for the network interface card may include either **Jumbo Packet** or **Jumbo Frames** depending on the manufacturer. If neither is listed under properties, your network card may not support this feature. You must use a network interface card that supports Jumbo Frames or Jumbo Packets.

To enable jumbo packets

1. Click the **Start** icon and select **Control Panel** in the menu.
2. Click **View by Large Icons** and select **Device Manager** in the list.
3. Under **Network Adapters**, locate the Ethernet network adapter, right-click the entry, and select **Properties** in the menu.
4. Select the **Advanced** tab.

5. Select the property **Jumbo Packet** and set the value to **9014 Bytes**.
6. Click **OK** to save the setting.

Connecting your camera

Use a Category 6 or higher rated Ethernet cable to connect the Mako G camera to the network interface card. Crossover cabling is not required but does work. The camera has circuitry to determine if a crossover cable is being used.



We recommend Category 6 (CAT6) or higher rated Ethernet cables for Mako G cameras. A different rating may not sustain peak interface bandwidth; leading to lost connectivity or dropped frames coming from the camera.

Optics

Mako G cameras are offered with the following lens mounts: C-Mount (default), CS-Mount, or M12-Mount (S-Mount). Lenses can be purchased directly from Allied Vision or from an Allied Vision distribution partner. Users need to select the desired focal length of the lens and appropriate optical format for the target camera model.

For more information on lens mount options for your Mako G camera, see the Modular Concept. For information on available lenses for your camera, see the Accessories webpage.

Accessories

We offer a wide range of accessories for use with Mako G cameras including:

- Gigabit Ethernet accessories, such as standard GigE components or PoE capable GigE components.
- Lenses for corresponding sensor sizes and resolutions.

For information on available lenses for your camera, see the Accessories webpage.



A list of recommended GigE components is available on the Allied Vision website. See the Hardware Selection for Allied Vision GigE Cameras application note at www.alliedvision.com/en/support/technical-papers-knowledge-base.html.

Software

Mako G cameras work with the following software options:

- Vimba Viewer or Vimba SDK
- Third-party software solutions

Powering up the camera

A camera power adapter for Mako G cameras is available from Allied Vision. See the Specifications chapter for connector definition and voltage specifications.



NOTICE

- Use only DC power supplies with insulated cases.
- For all power connections, use only shielded cables to avoid electromagnetic interference.
- Mako G cameras can source power from:
 - IEEE 802.3af (100 Mbps and 1000 Mbps), and
 - IEEE 802.3at Type 1 compliant PoE power sourcing equipment devices such as switches, injectors, or network interface card.



NOTICE

The camera is not intended to be connected to a DC distribution network. The maximum length for I/O cables must not exceed 30 meters.

Powering the camera via Hirose I/O port

Cameras powered by both the Hirose I/O port and the Gigabit Ethernet port use the power provided by Hirose I/O port only.

Powering the camera via PoE

Please note the following when using PoE accessories with Allied Vision PoE-capable GigE cameras:

- Mako G cameras conform to the IEEE 802.3at Type 1 standard for GigE.
- Ensure that your Power Sourcing Equipment (PSE) provides data over all four pairs.
- If the PSE uses only two out of four pairs for data, operation is limited to 10/100 Mbps. This translates to lower frame rates.
- If the PSE uses all four pairs for data, operation is in Gigabit (1000 Mbps) mode. Thus, allowing you to achieve the maximum possible frame rate.

Connecting to host application

After you have installed the **Vimba Viewer** or third-party application to your host computer, connect your Mako G camera via an Ethernet cable. If your camera is not PoE powered, connect the Hirose cable to power the camera.

Allied Vision software

All software packages provided by Allied Vision are free of charge and contain the following components:

- Drivers
- SDK for camera control and image acquisition
- Examples based on the provided APIs of the SDK
- Documentation and release notes
- Viewer application to operate and configure the cameras



Vimba Viewer documentation is included with the software download. After Vimba Viewer is installed on your host computer, documentation is located under `\Program Files\Allied Vision\Vimba`.

Third-party software

In addition to the software provided by Allied Vision, there are numerous GigE Vision standard compliant third-party software options available. In general, third-party software provides increased functionality such as image processing and video recording.

Allied Vision's Vimba SDK is based on the GenICam standard. GenICam-based third-party software automatically connects with Vimba's transport layers. Additionally, Vimba includes the Cognex Adapter for VisionPro.

Specifications



This chapter provides:

- Applied standards
- Technical specifications
- Absolute QE plots
- Spectral response plots
- ROI frame rate plots
- Comparison of feature availability in Mako G camera models
- Mechanical drawing and dimensions of standard housing model and tripod adapter
- Sensor position accuracy
- Maximum protrusion distance and filter diameter for C-Mount and CS-Mount

Applied standards

GigE Vision® The GigE Vision standard is an interface standard for digital machine vision cameras administered by the AIA that is widely supported in the machine vision industry. In contrast, Gigabit Ethernet is the network GigE Vision is built upon.

GenICam™ GenICam is a machine vision standard hosted by the EMVA. The aim of GenICam is to provide a generic configuration interface for cameras and devices independent of the used interface technology (for example, GigE Vision, USB3 Vision, DCAM IEEE 1394, Camera Link). This approach enables proper interoperability between GenICam compliant hardware and software solutions without the need for customization.

The GenICam standard consists of multiple modules that specify tasks to be solved. Allied Vision cameras and software make use of these modules, like the SFNC that standardizes feature names and types via an XML file or the transport layer interface (GenTL) that is used to grab images.

Shock and vibration

Mako G cameras were successfully tested according to the following standards:

- DIN ISO 9022-3-37-01-1, Random vibration testing
- DIN ISO 9022-3-30-03-1, Shock testing
- DIN ISO 9022-3-31-01-1, Bump testing

Notes on specifications

Dimensions and mass

The dimensions listed in the following tables are for Mako G standard housing models. Dimensions include the default lens mount and connectors but not the tripod and lens.

The mass listed in the following table are for Mako G standard housing models. Mass does not include the tripod and lens.

Frame memory

Normally, an image is captured and transported in consecutive steps. The image is taken, read out from the sensor, digitized and sent over the GigE network. Mako G cameras are equipped with an image buffer. Specifications tables for each camera show how many frames can be stored by each model.

The memory operates according to the FIFO principle. This makes addressing for individual images unnecessary.

Number of frames

The number of frames (**StreamHoldCapacity**) depends on resolution, pixel format, and packet size. Stated number of frames is typical for full resolution, *Mono8* or *BayerRG8*, and **GevSCPSPacketSize = 8192**.

Resolution and ROI frame rate

ROI frame rate is listed after the specification table. The resulting frame rate from changing sensor height from full image to a single line. Unless otherwise noted, sensors do not give an increase in readout speed with a reduction in width.

Unless otherwise stated, frame rate, exposure time control, trigger latency, and trigger jitter values are for 8-bit and 12-bit pixel formats only; that is, *Mono8*, *Bayer8*, *Mono12Packed*, *Bayer12Packed*, and *YUV411Packed*.

Resolution and ROI measurements

- Data was generated using **StreamBytesPerSecond = 124** Mbps (full bandwidth) and an 8-bit pixel format. Frame rates may be lower if using network hardware incapable of 124 Mbps.
- ROIs are taken as center image for maximum speed advantage, where feature **OffsetY** = (full sensor height – ROI height)/2.
- **BinningVertical** is horizontal row summing on sensor before readout. The frame rate for an ROI at the same effective height as binning is slower because the sensor still needs to read out the “fast readout rows” in ROI mode.

Frame rate and readout

Although the sensor is capable of higher frame rates, readout is limited by GigE bandwidth and exposure value. You can improve frame rates with a reduced ROI and shorter exposure values.

Absolute QE plots

Before reading the QE plots

- All measurements were done without optical filters. With optical filters, QE decreases by approximately 10 percent.
- The uncertainty in measurement of the QE values is ± 10.25 percent. This is mainly due to uncertainties in the measuring apparatus itself (Ulbricht sphere, optometer).
- Manufacturing tolerance of the sensor increases overall uncertainty.

Sony CCD and CMOS monochrome sensors

The curve in the absolute QE plots shown in this chapter were calculated from a single measured QE for monochrome sensors. The shape of the curve is taken from the sensor data sheet but the values have been adjusted based on this measured value.

Sony CCD and CMOS color sensors

The curves in the absolute QE plots shown in this chapter were calculated from three measured QE values for color sensors. The shape of the curves are taken from the sensor data sheet but the values have been adjusted based on these measured values.

ON Semi, CMOSIS/ams, and Teledyne e2v CMOS sensors

The curve in the absolute QE plots shown in this chapter is taken from the sensor manufacturer data sheet.

The information was correct at the time of publishing.

Wavelength

The wavelength range in the absolute QE plots reflects the information available in the sensor manufacturer data sheet at the time of publishing. Many color sensors are documented by the sensor manufacturer only for wavelengths from 400 nm to 700 nm.

Spectral response plots

The curves in the spectral response plots shown in this chapter were calculated from measured quantum efficiencies at 448 nm, 529 nm, and 632 nm. The shape of the curve is taken from the sensor data sheet but the values have been adjusted based on these measured values.

Specifications common to all models

The following table provides specifications common to all Mako G models.

Feature	Specification
Default lens mount	C-Mount
Optional lens mount	<ul style="list-style-type: none"> CS-Mount M12-Mount (S-Mount) adapter
Default optical filter	<ul style="list-style-type: none"> Monochrome and NIR models: No filter¹ Color models: IRC Hoya C-5000 (22 mm)
Optional optical filters	<ul style="list-style-type: none"> Protection glass B 270 (ASG) IRC Hoya C-5000 (IR cut filter) IRC type Jenofilt 217 (IR cut filter) IRP RG715 (IR pass filter) IRP RG830 (IR pass filter)
Opto-isolated I/O	1 input, 3 outputs
Operating temperature	+5 °C to +45 °C housing temperature
Storage temperature	-10°C to +70 °C ambient temperature (without condensation)
Operating humidity	20 to 80% non-condensing
Power requirements	12 to 24 VDC AUX or IEEE 802.3at Type 1 PoE
Camera dimensions (L × W × H)	60.5 × 29.2 × 29.2 mm
Mass (typical)	80 g
Interface standard	<ul style="list-style-type: none"> IEEE 802.3 1000BASE-T (Gigabit Ethernet) and IEEE 802.3at Type 1 (PoE) GigE Vision Standard V1.2
Camera control standard	GenICam SFNC V1.2.1
Temperature monitoring	Available for main board only. Resolution: 0.031; Accuracy: ±1 °C

¹ As monochrome and NIR models do not have an optical filter, always attach a dust cap when a lens is not attached to minimize the possibility of contaminants falling on the sensor surface.

Table 7: Specifications common to all Mako G models

Mako G-030 series

The following table provides model series specifications. The values are valid for Mako G-030B and G-030C models. For specifications common to all models, see [Specifications common to all models](#).

Feature	Specification	
	Mako G-030B	Mako G-030C
Sensor model	CMOSIS/ams CMV300-3E7M1WP	CMOSIS/ams CMV300-3E7C1WP
Resolution (H × V)	644 × 484 0.3 MP	
Sensor type	CMOS	
Shutter type	Global	
Sensor format	Type 1/3	
Sensor size	5.9 mm diagonal	
Pixel size	7.4 μm × 7.4 μm	
Maximum frame rate at full resolution	309 fps	
Maximum image bit depth	12-bit	
Image buffer	64 MB	
StreamHoldCapacity	Up to 99 frames at full resolution	
Monochrome pixel formats	Mono8, Mono12Packed, Mono12	Mono8
YUV color pixel formats		YUV411Packed, YUV422Packed, YUV444Packed
RGB color pixel formats		RGB8Packed, BGR8Packed
RAW pixel formats		BayerRG8, BayerRG12Packed, BayerRG12
Exposure time control	83 μs to 2 s; 1 μs increments	
Gain control	0 to 26 dB; 1 dB increments	
Decimation	Horizontal and Vertical: 1, 2, 4 factor	
Power consumption	2.1 W at 12 VDC; 2.3 W PoE	
Trigger latency ¹	Idle state: 3.1 μs; Frame valid state: 3.1 μs	

Table 8: Mako G-030 model series specifications (sheet 1 of 2)

Feature	Specification	
	Mako G-030B	Mako G-030C
Trigger jitter ¹	Idle state: $\pm 1.2 \mu\text{s}$; Frame valid state: $\pm 3.1 \mu\text{s}$	

¹ These values are calculated directly from the microcontroller source. These values are only valid for pixel formats < 16 bits per pixel and applicable in both Idle and Frame valid states:

- Idle state: sensor is ready and camera is idle, waiting for the next trigger.
- Frame valid state: sensor is reading out and camera is busy. If next frame is requested by an external trigger in this state, higher latency may occur as compared to the Idle state.

Table 8: Mako G-030 model series specifications (sheet 2 of 2)

Absolute QE

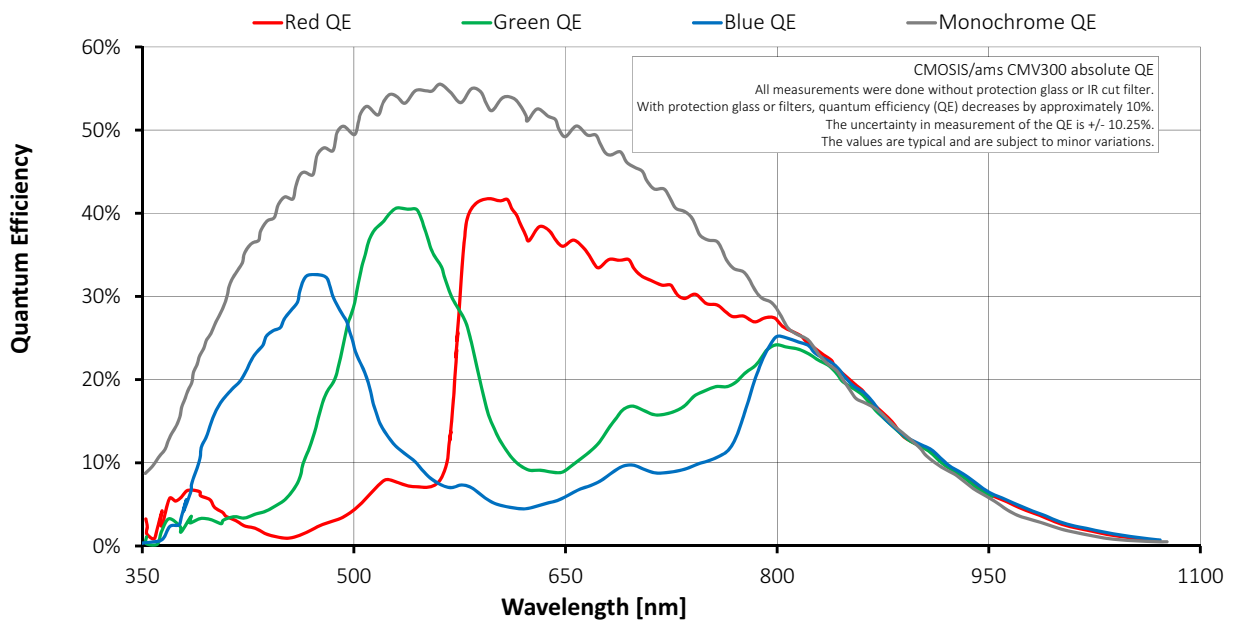

Figure 2: Mako G-030 (CMOSIS/ams CMV300) absolute QE

ROI frame rate

$$\text{Max. frame rate} = \frac{1}{204 \mu\text{s} + 6.25 \mu\text{s} \times \text{ROI height}}$$

Maximum frame rate at full resolution according to formula: 309 fps

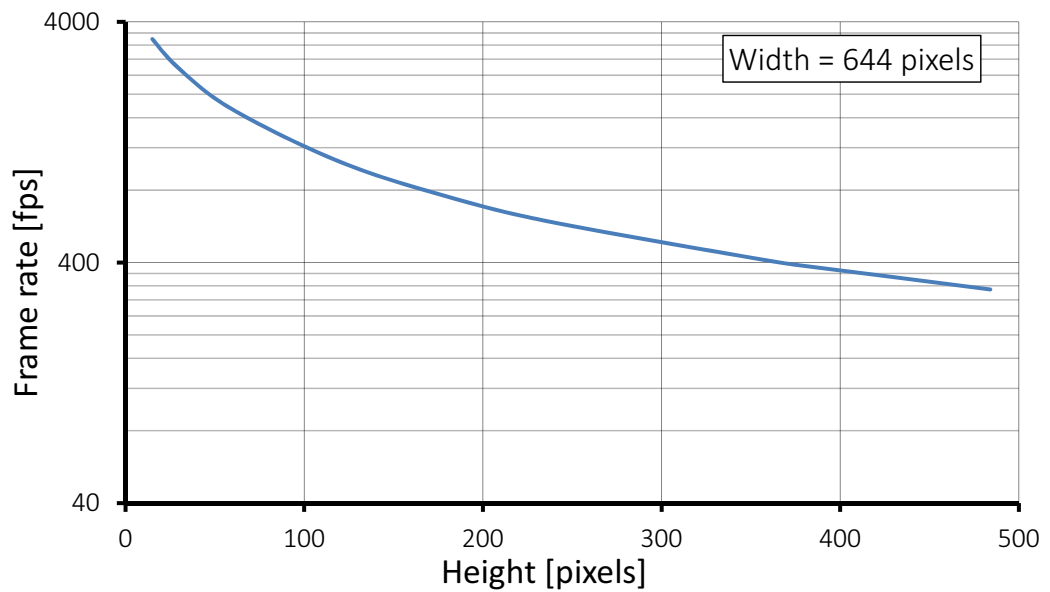

Figure 3: Mako G-030 frame rate as a function of ROI height

Height	Frame rate (fps)	Height	Frame rate (fps)
484	309.0	180	752.0
480	312.0	120	1048.0
384	384.0	60	1727.0
360	407.0	30	2554.0
240	586.0	15	3393.0

Table 9: Frame rate as a function of ROI height (Width=644 pixels)



There is an increase in frame rate with reduced width if the camera is bandwidth limited.

Mako G-032 series

The following table provides model series specifications. The values are valid for Mako G-032B and G-032C models. For specifications common to all models, see [Specifications common to all models](#).

Feature	Specification	
	Mako G-032B	Mako G-032C
Sensor model	Sony ICX424AL with HAD CCD™ technology	Sony ICX424AQ with Wfine HADCCD™ technology
Resolution (H × V)	658 × 492 0.3 MP	
Sensor type	Interline CCD, Progressive Scan	
Shutter type	Global	
Sensor format	Type 1/3	
Sensor size	6.0 mm diagonal	
Pixel size	7.4 μm × 7.4 μm	
Maximum frame rate at full resolution	102.3 fps	
Maximum image bit depth	12-bit	
Image buffer	64 MB	
StreamHoldCapacity	Up to 202 frames at full resolution	
Monochrome pixel formats	Mono8, Mono12Packed, Mono12	Mono8
YUV color pixel formats		YUV411Packed, YUV422Packed, YUV444Packed
RGB color pixel formats		RGB8Packed, BGR8Packed
RAW pixel formats		BayerRG8, BayerRG12, BayerRG12Packed
Exposure time control	10 μs to 93 s; 1 μs increments	
Gain control	0 to 30 dB; 1 dB increments	
Binning	Horizontal: 1 to 8 columns Vertical: 1 to 14 rows	
Power consumption	2.4 W at 12 VDC; 2.8 W PoE	
Trigger latency ¹	Idle state: 7.2 μs; Frame valid state: 16.9 μs	

Table 10: Mako G-032 model series specifications (sheet 1 of 2)

Feature	Specification	
	Mako G-032B	Mako G-032C
Trigger jitter ¹	Idle state: $\pm 4.0 \mu\text{s}$; Frame valid state: $\pm 13.7 \mu\text{s}$	
¹ It is possible to start the exposure of the next frame while the previous frame is read out: <ul style="list-style-type: none"> • Idle state: sensor is ready and camera is idle, waiting for the next trigger. • Frame valid state: sensor is reading out and camera is busy. If next frame is requested by an external trigger in this state, higher latency may occur as compared to the Idle state. 		

Table 10: Mako G-032 model series specifications (sheet 2 of 2)

Absolute QE

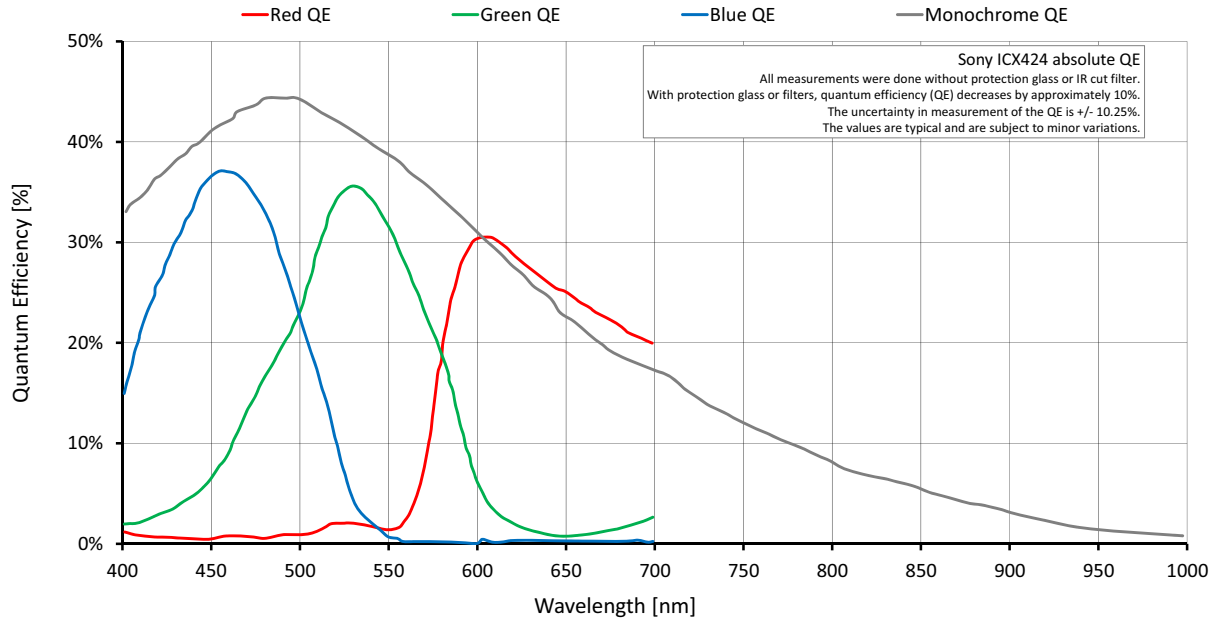

Figure 4: Mako G-032 (Sony ICX424) absolute QE

Spectral response

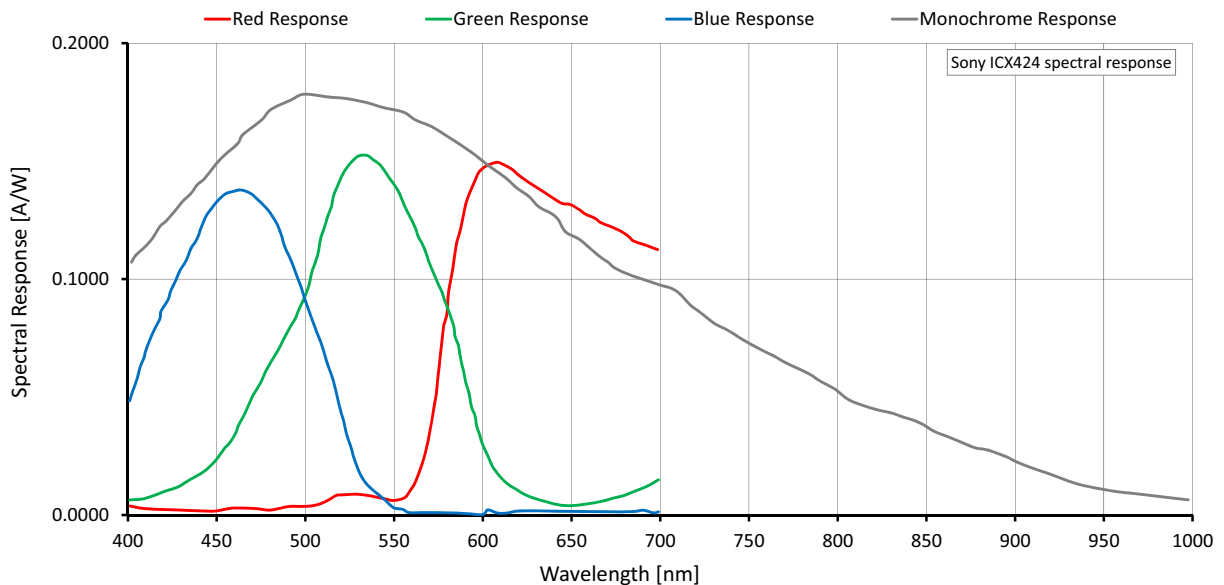

Figure 5: Mako G-032 (Sony ICX424) spectral response

ROI frame rate

$$\text{Max. frame rate} = \frac{1}{19.46 \mu\text{s} \times \text{ROI height} + 2.29 \mu\text{s} \times (492 - \text{ROI height}) + 195.81 \mu\text{s}}$$

Maximum frame rate at full resolution according to formula: 102.3 fps

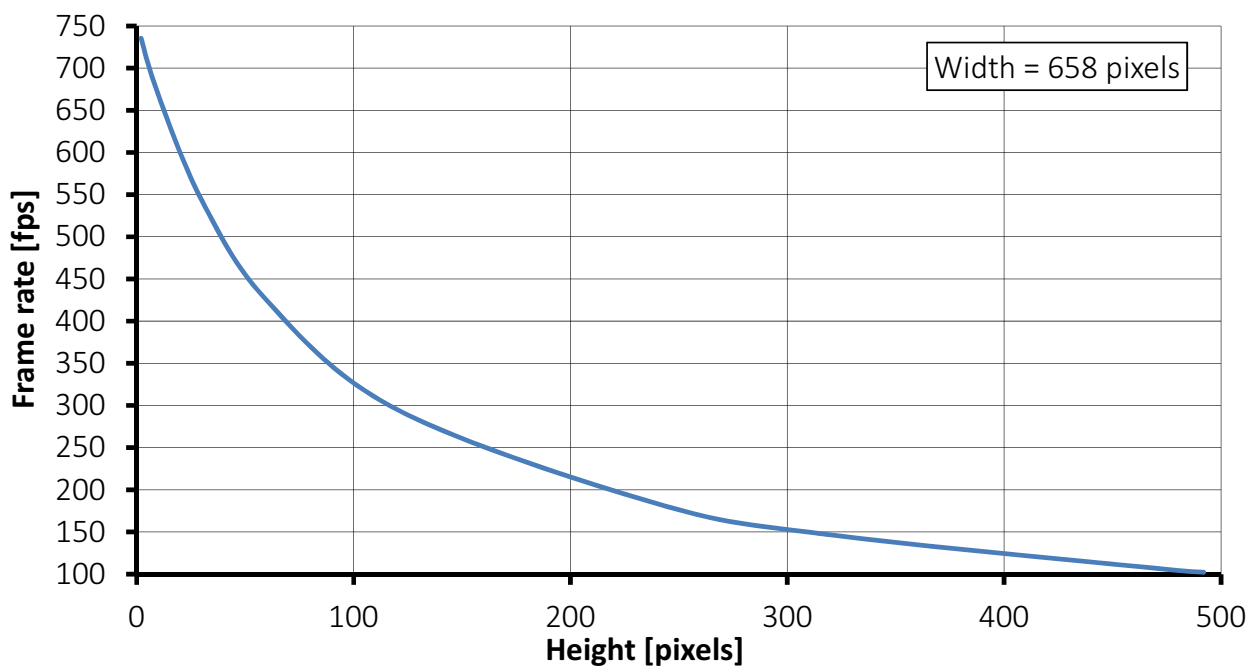

Figure 6: Mako G-032 frame rate as a function of ROI height

Height	Frame rate (fps)	Height	Frame rate (fps)
492	102.3	60	424.5
480	104.5	30	543.3
320	146.6	10	667.9
240	183.5	2	735.4
120	295.3		

Table 11: Frame rate as a function of ROI height (Width=658 pixels)



Frame rate = theoretical maximum frame rate (in fps) of the CCD sensor according to given formula.

Mako G-040 series

The following table provides model series specifications. The values are valid for Mako G-040B and G-040C models. For specifications common to all models, see [Specifications common to all models](#).

Feature	Specification	
	Mako G-040B	Mako G-040C
Sensor model	Sony IMX287LLR Exmor	Sony IMX287LQR Exmor
Resolution (H × V)	728 × 544 0.4 MP	
Sensor type	CMOS	
Shutter type	Pregius® global shutter	
Sensor format	Type 1/2.9	
Sensor size	6.3 mm diagonal	
Pixel size	6.9 μm × 6.9 μm	
Chief ray angle ¹	0.0°	
Maximum frame rate at full resolution	286 fps (295.7 fps burst mode)	
Maximum image bit depth	12-bit	
Image buffer	64 MB	
StreamHoldCapacity	Up to 165 frames at full resolution	
Monochrome pixel formats	Mono8, Mono12Packed, Mono12	Mono8
YUV color pixel formats		YUV411Packed, YUV422Packed, YUV444Packed
RGB color pixel formats		RGB8Packed, BGR8Packed
RAW pixel formats		BayerRG8, BayerRG12, BayerRG12Packed
Exposure time control ²	Pixel format	Value
	Mono8, Mono12Packed, BayerRG8 BayerRG12Packed, YUV411Packed	19 μs to 85.9 s; 5.76 μs increments
	Mono12, BayerRG12, YUV422Packed	21 μs to 85.9 s; 7.68 μs increments
	RGB8Packed, BGR8Packed, YUV444Packed	25 μs to 85.9 s; 11.52 μs increments
Gain control	0 to 40 dB; 0.1 dB increments	

Table 12: Mako G-040 model series specifications (sheet 1 of 2)

Feature	Specification	
	Mako G-040B	Mako G-040C
Binning	Horizontal: 1 to 4 pixels; Vertical: 1 to 4 rows	
Decimation	Horizontal and Vertical: 1, 2, 4, 8 factor	
Power consumption	2.43 W at 12 VDC; 2.69 W PoE	
Trigger latency ³	Pixel format	Value
	Mono8, Mono12Packed, BayerRG8 BayerRG12Packed, YUV411Packed	17.28 μ s
	Mono12, BayerRG12, YUV422Packed	23.04 μ s
	RGB8Packed, BGR8Packed, YUV444Packed	34.56 μ s
Trigger jitter ³	Pixel format	Value
	Mono8, Mono12Packed, BayerRG8 BayerRG12Packed, YUV411Packed	\pm 2.88 μ s
	Mono12, BayerRG12, YUV422Packed	\pm 3.84 μ s
	RGB8Packed, BGR8Packed, YUV444Packed	\pm 5.76 μ s
Time between exposures	Pixel format	Value
	Mono8, Mono12Packed, BayerRG8 BayerRG12Packed, YUV411Packed	101 μ s
	Mono12, BayerRG12, YUV422Packed	140 μ s
	RGB8Packed, BGR8Packed, YUV444Packed	217 μ s

¹ For more information on chief ray angle, contact Allied Vision support.

² Whenever pixel format is changed, exposure adjusts itself to the nearest multiple of the exposure increment.

³ These values are calculated directly from the microcontroller source. There is no differentiation between Idle and Frame valid states for this sensor.

Table 12: Mako G-040 model series specifications (sheet 2 of 2)

Absolute QE

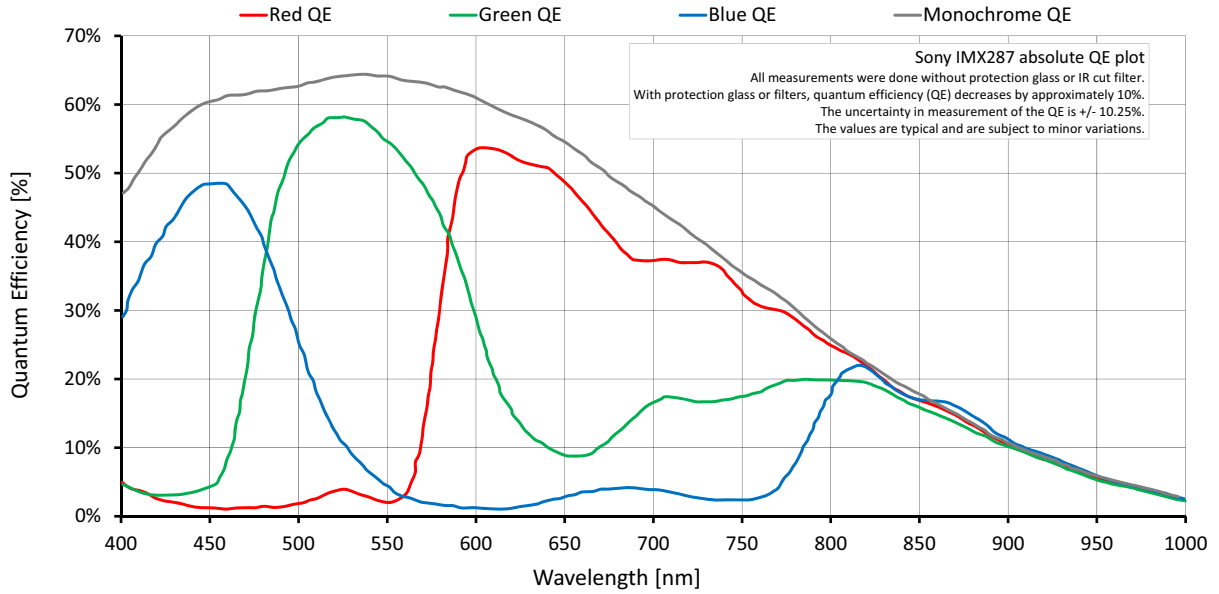

Figure 7: Mako G-040 (Sony IMX287) absolute QE

Spectral response

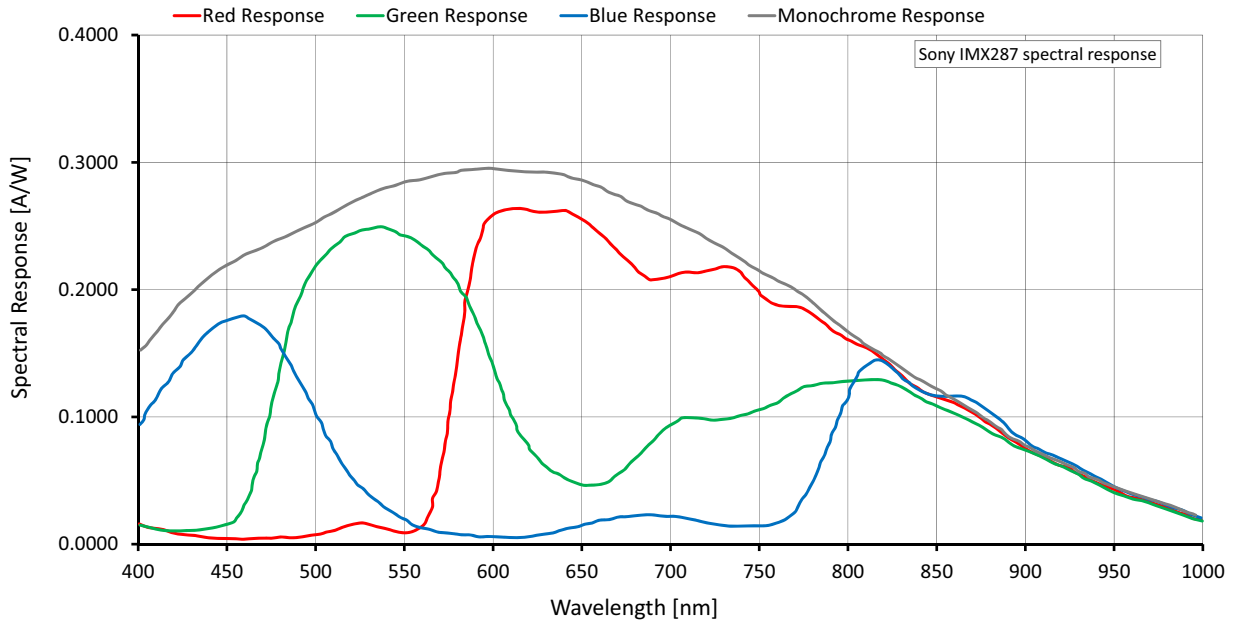

Figure 8: Mako G-040 (Sony IMX287) spectral response

ROI frame rate

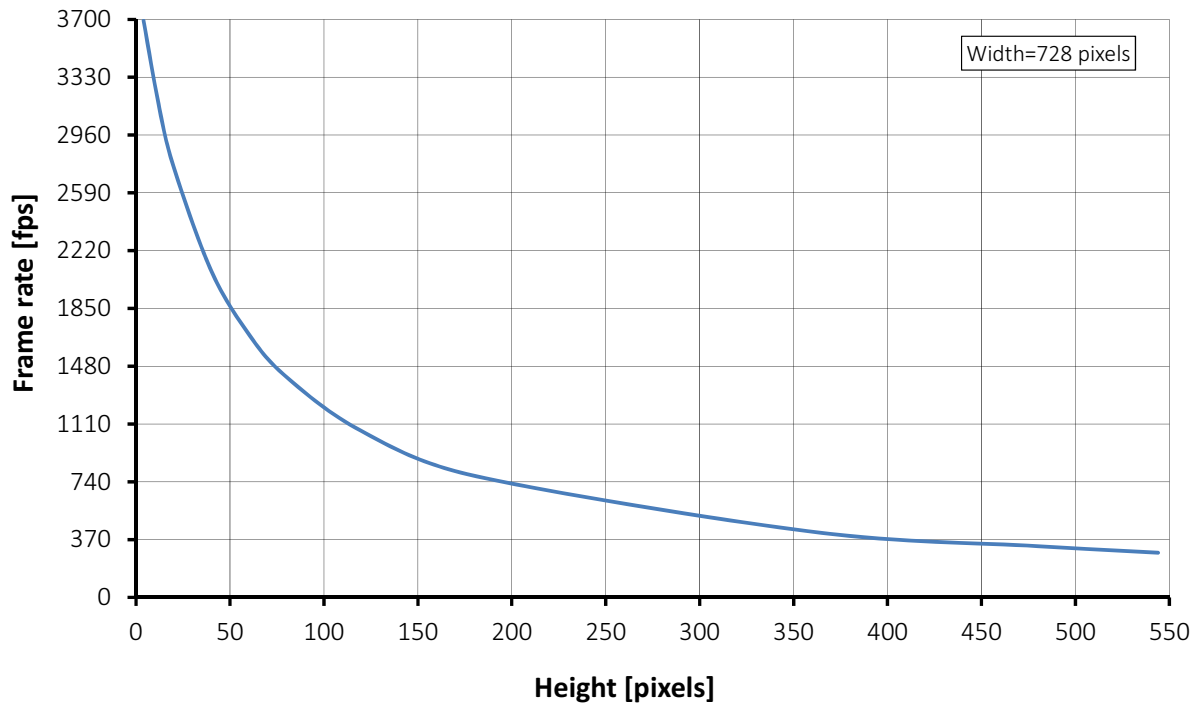

Figure 9: Mako G-040 frame rate as a function of ROI height

Height	Frame rate (fps)	Height	Frame rate (fps)
544	286.0	60	1685.5
480	328.2	40	2091.6
360	420.4	20	2755.6
180	778.5	12	3156.5
120	1065.0	4	3692.7
80	1411.4		

Table 13: Frame rate as a function of ROI height (Width=728 pixels)



There is an increase in frame rate with reduced width if the camera is bandwidth limited. Reducing the exposure time may result in higher frame rates.

Mako G-125 series

The following table provides model series specifications. The values are valid for Mako G-125B and G-125C models. For specifications common to all models, see [Specifications common to all models](#).

Feature	Specification	
	Mako G-125B	Mako G-125C
Sensor model	Sony ICX445ALA with EXview HAD CCD™ technology	Sony ICX445AQA with EXview HAD CCD™ technology
Resolution (H × V)	1292 × 964 1.2 MP	
Sensor type	Interline CCD, Progressive Scan	
Shutter type	Global	
Sensor format	Type 1/3	
Sensor size	6.0 mm diagonal	
Pixel size	3.75 μm × 3.75 μm	
Maximum frame rate at full resolution	30.3 fps	
Maximum image bit depth	12-bit	
Image buffer	64 MB	
StreamHoldCapacity	Up to 52 frames at full resolution	
Monochrome pixel formats	Mono8, Mono12Packed, Mono12	Mono8
YUV color pixel formats		YUV411Packed, YUV422Packed, YUV444Packed
RGB color pixel formats		RGB8Packed, BGR8Packed
RAW pixel formats		BayerRG8, BayerRG12, BayerRG12Packed
Exposure time control	12 μs to 84 s; 1 μs increments	
Gain control	0 to 30 dB; 1 dB increments	
Binning	Horizontal: 1 to 8 columns Vertical: 1 to 14 rows	
Power consumption	2.3 W at 12 VDC; 2.7 W PoE	
Trigger latency ¹	Idle state: 8.0 μs; Frame valid state: 25.0 μs	

Table 14: Mako G-125 model series specifications (sheet 1 of 2)

Feature	Specification	
	Mako G-125B	Mako G-125C
Trigger jitter ¹	Idle state: $\pm 4.0 \mu\text{s}$; Frame valid state: $\pm 21.0 \mu\text{s}$	
¹ It is possible to start the exposure of the next frame while the previous frame is read out: <ul style="list-style-type: none"> • Idle state: sensor is ready and camera is idle, waiting for the next trigger. • Frame valid state: sensor is reading out and camera is busy. If next frame is requested by an external trigger in this state, higher latency may occur as compared to the Idle state. 		

Table 14: Mako G-125 model series specifications (sheet 2 of 2)

Absolute QE

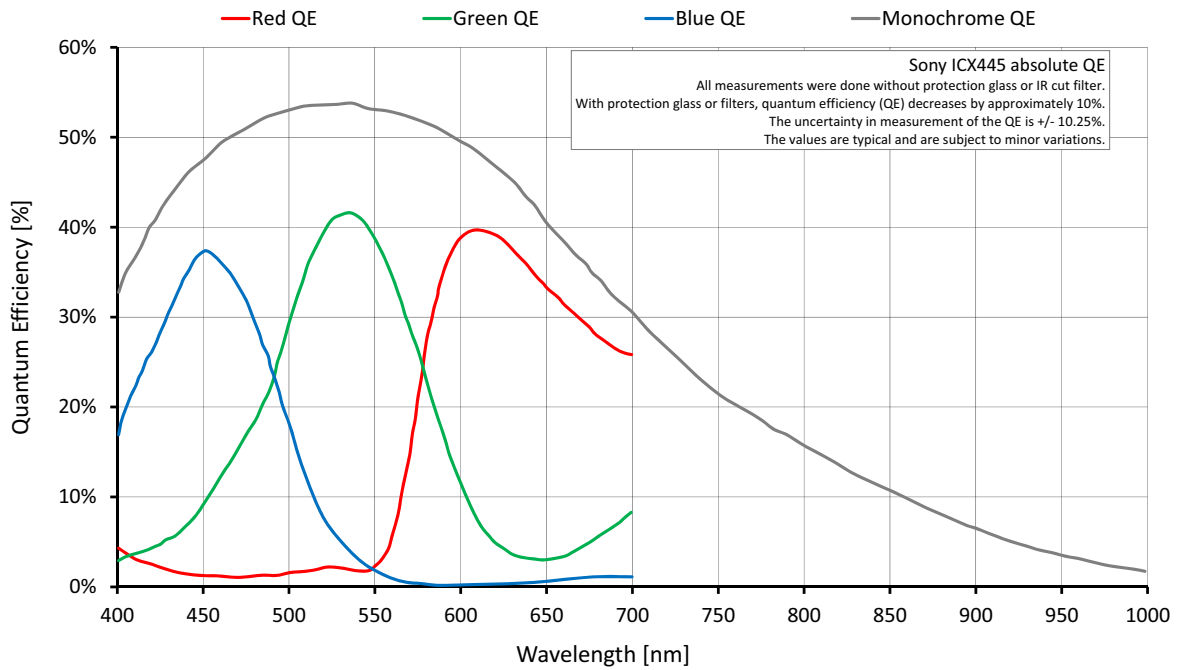

Figure 10: Mako G-125 (Sony ICX445) absolute QE

Spectral response

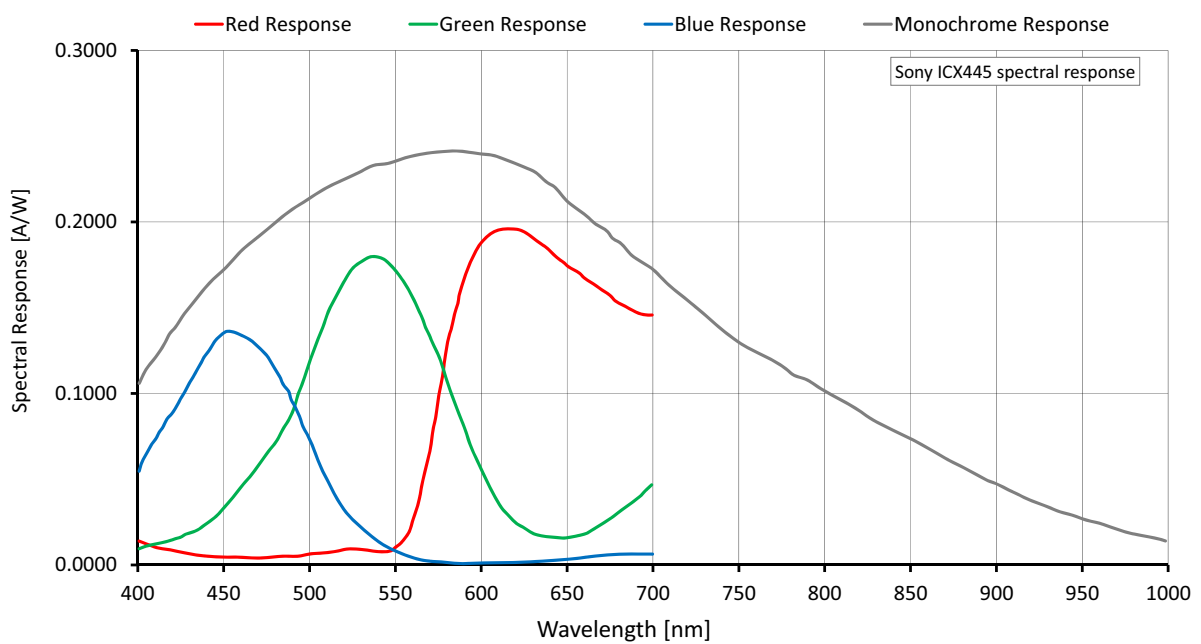

Figure 11: Mako G-125 (Sony ICX445) spectral response

ROI frame rate

$$\text{Max. frame rate} = \frac{1}{34.01 \mu\text{s} \times \text{ROI height} + 3.09 \mu\text{s} \times (964 - \text{ROI height}) + 176.42 \mu\text{s}}$$

Maximum frame rate at full resolution according to formula: 30.3 fps

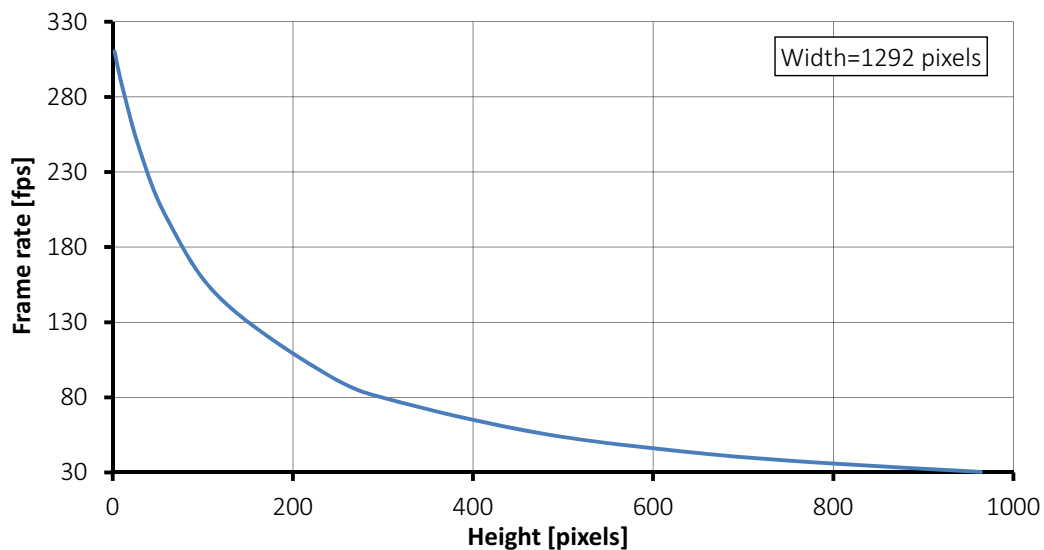

Figure 12: Mako G-125 frame rate as a function of ROI height

Height	Frame rate (fps)	Height	Frame rate (fps)
964	30.3	240	94.4
960	30.4	120	145.5
768	37.1	60	199.3
640	43.5	30	244.5
480	55.5	10	288.1
320	76.5	2	310.3

Table 15: Frame rate as a function of ROI height (Width=1292 pixels)



Frame rate = theoretical maximum frame rate (in fps) of the CCD sensor according to given formula.

Mako G-131 series

The following table provides model series specifications. The values are valid for Mako G-131B and G-131C models. For specifications common to all models, see [Specifications common to all models](#).

Feature	Specification			
	Mako G-131B		Mako G-131C	
Sensor model	Teledyne e2v EV76C560			
Resolution (H × V)	1280 × 1024 1.3 MP			
Sensor type	CMOS			
Shutter type	Global, Global Reset, and Rolling			
Sensor format	Type 1/1.8			
Sensor size	8.7 mm diagonal			
Pixel size	5.3 μm × 5.3 μm			
Chief ray angle ¹	12°			
Maximum frame rate at full resolution	62 fps			
Maximum image bit depth	10-bit			
Image buffer	64 MB			
StreamHoldCapacity	Up to 50 frames at full resolution			
Monochrome pixel formats	Mono8, Mono10		Mono8	
YUV color pixel formats			YUV411Packed, YUV422Packed, YUV444Packed	
RGB color pixel formats			RGB8Packed, BGR8Packed	
RAW pixel formats			BayerBG8, BayerBG10	
Exposure time control ²	Pixel format	Global shutter mode	Global Reset shutter mode	Rolling shutter mode
	Mono8, Mono10, BayerBG8, BayerBG10, YUV411Packed, YUV422Packed	12 μs to 1.012 s; 1 μs increments	12 μs to 0.978 s; 1 μs increments	12 μs to 0.994 s; 1 μs increments

Table 16: Mako G-131 model series specifications (sheet 1 of 2)

Feature	Specification			
	Mako G-131B		Mako G-131C	
	RGB8Packed, BGR8Packed, YUV444Packed	12 μ s to 2.124 s; 1 μ s increments	12 μ s to 2.053 s; 1 μ s increments	12 μ s to 2.086 s; 1 μ s increments
Gain control	0 to 24 dB; 1 dB increments			
Binning ³	Horizontal: 1 to 2 pixels Vertical: 1 to 2 rows Teledyne e2v sensors support 1 \times 1 and 2 \times 2 binning			
Decimation	Horizontal and Vertical: 1, 2, 4, 8 factor			
Power consumption	2.0 W at 12 VDC; 2.2 W PoE			
Trigger latency ⁴	Idle state: 32.6 μ s; Frame valid state: 32.6 μ s			
Trigger jitter ⁴	Idle state: \pm 8.1 μ s; Frame valid state: \pm 8.1 μ s			

¹ For more information on chief ray angle, contact Allied Vision support.

² The Teledyne e2v sensor does not support exposure duration via external level trigger.

³ Mako G-131 supports **BinningHorizontalMode = Sum or Average** and **BinningVerticalMode = Sum or Average**.

⁴ These values are calculated directly from the microcontroller source. These values are only valid for pixel formats < 16 bits per pixel and applicable in both Idle and Frame valid states:

- Idle state: sensor is ready and camera is idle, waiting for the next trigger.
- Frame valid state: sensor is reading out and camera is busy. If next frame is requested by an external trigger in this state, higher latency may occur as compared to the Idle state.

Table 16: Mako G-131 model series specifications (sheet 2 of 2)



Overlapping exposure and readout

The Teledyne e2v sensor does not support overlapped exposure and readout in hardware trigger mode or in global reset mode.

Absolute QE

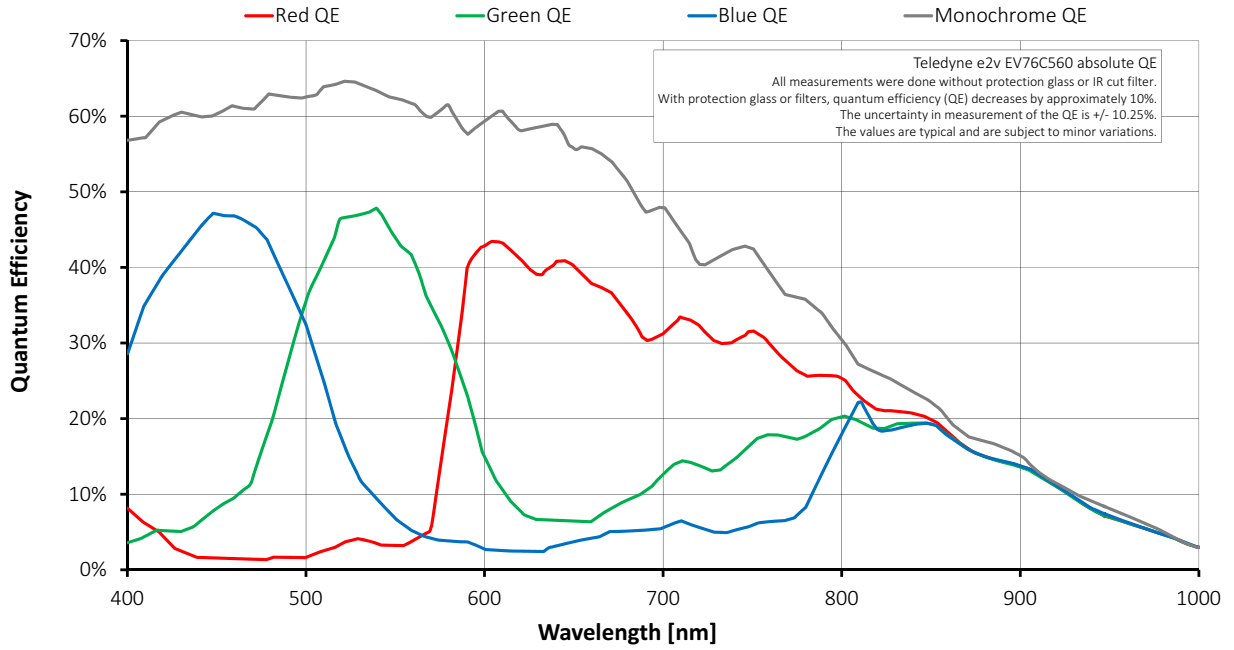

Figure 13: Mako G-131 (Teledyne e2v EV76C560) absolute QE

ROI frame rate

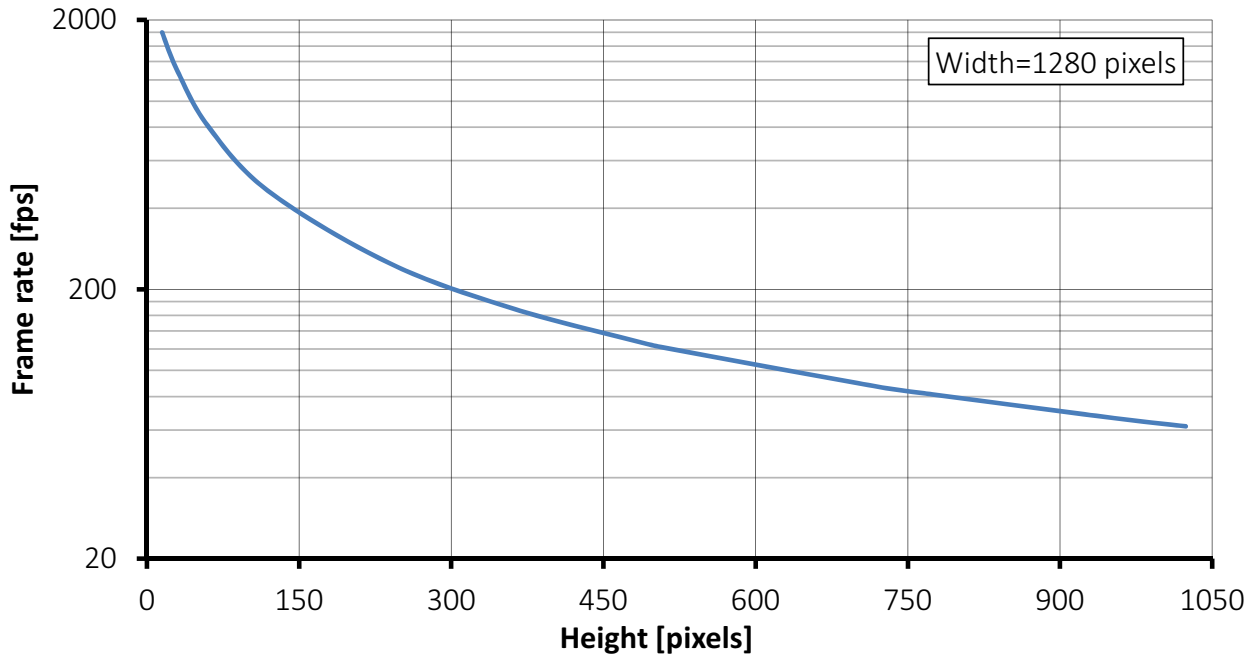

Figure 14: Mako G-131 frame rate as a function of ROI height

Height	Frame rate (fps)	Height	Frame rate (fps)
1024	62.0	360	170.0
960	66.0	240	249.0
768	82.0	120	462.0
720	87.0	60	809.0
512	121.0	30	1295.0
480	129.0	15	1798.0

Table 17: Frame rate as a function of ROI height (Width=1280 pixels)



There is an increase in frame rate with reduced width if the camera is bandwidth limited.

Mako G-158 series

The following table provides model series specifications. The values are valid for Mako G-158B and G-158C models. For specifications common to all models, see [Specifications common to all models](#).

Feature	Specification	
	Mako G-158B	Mako G-158C
Sensor model	Sony IMX273LLR Exmor	Sony IMX273LQR Exmor
Resolution (H × V)	1456 × 1088 1.58 MP	
Sensor type	CMOS	
Shutter type	Pregius® global shutter	
Sensor format	Type 1/2.9	
Sensor size	6.3 mm diagonal	
Pixel size	3.45 μm × 3.45 μm	
Chief ray angle ¹	0.0°	
Maximum frame rate at full resolution	75.2 fps (78.9 fps burst mode)	
Maximum image bit depth	12-bit	
Image buffer	64 MB	
StreamHoldCapacity	Up to 41 frames at full resolution	
Monochrome pixel formats	Mono8, Mono12Packed, Mono12	Mono8
YUV color pixel formats		YUV411Packed, YUV422Packed, YUV444Packed
RGB color pixel formats		RGB8Packed, BGR8Packed
RAW pixel formats		BayerRG8, BayerRG12, BayerRG12Packed
Exposure time control ²	Pixel format	Value
	Mono8, Mono12Packed, BayerRG8 BayerRG12Packed, YUV411Packed	24 μs to 85.9 s; 11.2 μs increments
	Mono12, BayerRG12, YUV422Packed	28 μs to 85.9 s; 14.88 μs increments
	RGB8Packed, BGR8Packed, YUV444Packed	36 μs to 85.9 s; 22.4 μs increments
Gain control	0 to 40 dB; 0.1 dB increments	

Table 18: Mako G-158 model series specifications (sheet 1 of 2)

Feature	Specification	
	Mako G-158B	Mako G-158C
Binning	Horizontal: 1 to 4 pixels; Vertical: 1 to 4 rows	
Decimation	Horizontal and Vertical: 1, 2, 4, 8 factor	
Power consumption	2.43 W at 12 VDC; 2.68 W PoE	
Trigger latency ³	Pixel format	Value
	Mono8, Mono12Packed, BayerRG8 BayerRG12Packed, YUV411Packed	33.6 μ s
	Mono12, BayerRG12, YUV422Packed	44.64 μ s
	RGB8Packed, BGR8Packed, YUV444Packed	67.2 μ s
Trigger jitter ³	Pixel format	Value
	Mono8, Mono12Packed, BayerRG8 BayerRG12Packed, YUV411Packed	\pm 5.6 μ s
	Mono12, BayerRG12, YUV422Packed	\pm 7.44 μ s
	RGB8Packed, BGR8Packed, YUV444Packed	\pm 11.2 μ s
Time between exposures	Pixel format	Value
	Mono8, Mono12Packed, BayerRG8 BayerRG12Packed, YUV411Packed	210 μ s
	Mono12, BayerRG12, YUV422Packed	285 μ s
	RGB8Packed, BGR8Packed, YUV444Packed	434 μ s

¹ For more information on chief ray angle, contact Allied Vision support.

² Whenever pixel format is changed, exposure adjusts itself to the nearest multiple of the exposure increment.

³ These values are calculated directly from the microcontroller source. There is no differentiation between Idle and Frame valid states for this sensor.

Table 18: Mako G-158 model series specifications (sheet 2 of 2)

Absolute QE

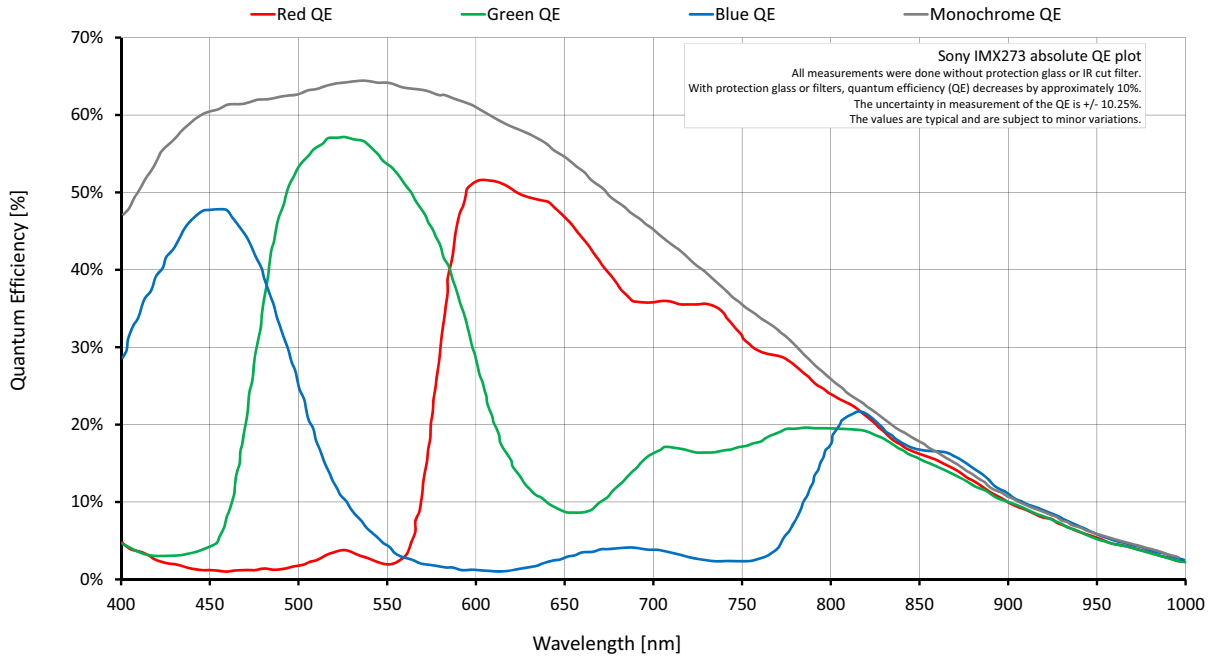

Figure 15: Mako G-158 (Sony IMX273) absolute QE

Spectral response

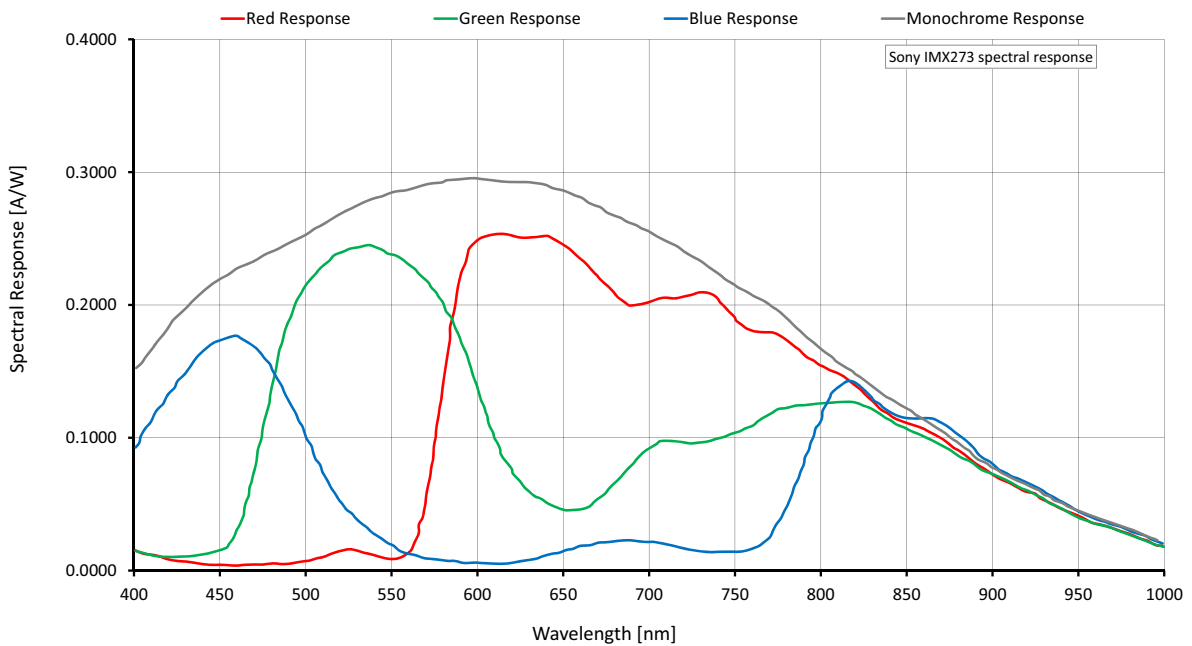

Figure 16: Mako G-158 (Sony IMX273) spectral response

ROI frame rate

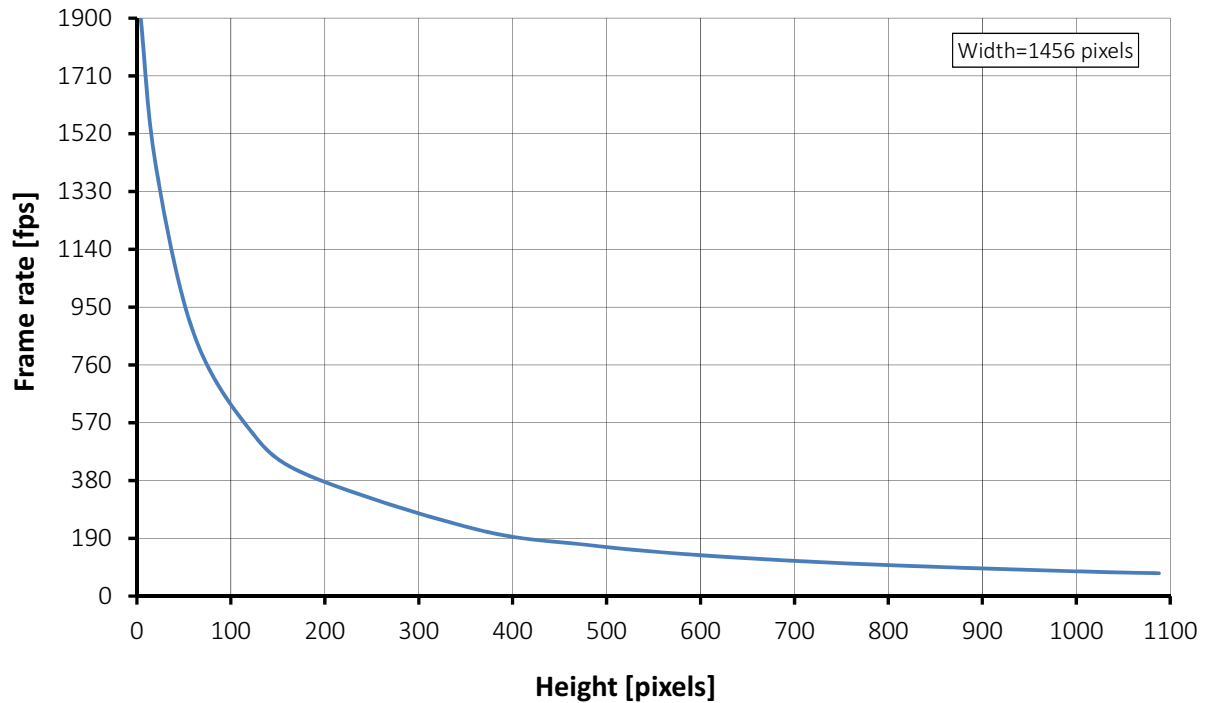

Figure 17: Mako G-158 frame rate as a function of ROI height

Height	Frame rate (fps)	Height	Frame rate (fps)
1088	75.2	360	220.5
1080	75.6	180	400.4
1024	79.6	120	547.8
960	85.2	60	866.9
768	105.9	20	1417.2
600	134.5	4	1899.7
480	168.1		

Table 19: Frame rate as a function of ROI height (Width=1456 pixels)



There is an increase in frame rate with reduced width if the camera is bandwidth limited. Reducing the exposure time may result in higher frame rates.

Mako G-192 series

The following table provides model series specifications. The values are valid for Mako G-192B and G-192C models. For specifications common to all models, see [Specifications common to all models](#).

Feature	Specification		
	Mako G-192B	Mako G-192C	
Sensor model	Teledyne e2v EV76C570		
Resolution (H × V)	1600 × 1200 1.9 MP		
Sensor type	CMOS		
Shutter type	Global, Global Reset, and Rolling		
Sensor format	Type 1/1.8		
Sensor size	9 mm diagonal		
Pixel size	4.5 μm × 4.5 μm		
Chief Ray Angle ¹	12°		
Maximum frame rate at full resolution	60 fps		
Maximum image bit depth	10-bit		
Image buffer	64 MB		
StreamHoldCapacity	Up to 34 frames at full resolution		
Monochrome pixel formats	Mono8, Mono10	Mono8	
YUV color pixel formats		YUV411Packed, YUV422Packed, YUV444Packed	
RGB color pixel formats		RGB8Packed, BGR8Packed	
RAW pixel formats		BayerBG8, BayerBG10	
Exposure time control ²	Pixel format	Global or Rolling shutter mode	Global Reset shutter mode
	Mono8, Mono10, BayerBG8, BayerBG10, YUV411Packed, YUV422Packed	14 μs to 0.891 s; 1 μs increments	14 μs to 0.874 s; 1 μs increments
	RGB8Packed, BGR8Packed, YUV444Packed	14 μs to 1.870 s; 1 μs increments	14 μs to 1.835 s; 1 μs increments
Gain control	0 to 24 dB; 1 dB increments		

Table 20: Mako G-192 model series specifications (sheet 1 of 2)

Feature	Specification	
	Mako G-192B	Mako G-192C
Binning ³	Horizontal: 1 to 2 pixels Vertical: 1 to 2 rows Teledyne e2v sensors support 1x1 and 2x2 binning.	
Decimation	Horizontal and Vertical: 1, 2, 4, 8 factor	
Power consumption	2.1 W at 12 VDC; 2.4 W PoE	
Trigger latency ⁴	Idle state: 27.7 μ s; Frame valid state: 27.7 μ s	
Trigger jitter ⁴	Idle state: \pm 6.9 μ s; Frame valid state: \pm 6.9 μ s	

¹ For more information on chief ray angle, contact Allied Vision support.

² The Teledyne e2v sensor does not support exposure duration via external level trigger.

³ Mako G-192 supports **BinningHorizontalMode = Sum or Average** and **BinningVerticalMode = Sum or Average**.

⁴ These values are calculated directly from the microcontroller source. These values are only valid for pixel formats < 16 bits per pixel and applicable in both Idle and Frame valid state:

- Idle state: sensor is ready and camera is idle, waiting for the next trigger.
- Frame valid state: sensor is reading out and camera is busy. If next frame is requested by an external trigger in this state, higher latency may occur as compared to the Idle state.

Table 20: Mako G-192 model series specifications (sheet 2 of 2)



Overlapping exposure and readout

The Teledyne e2v sensor does not support overlapped exposure and readout in hardware trigger mode or in global reset mode.

Absolute QE

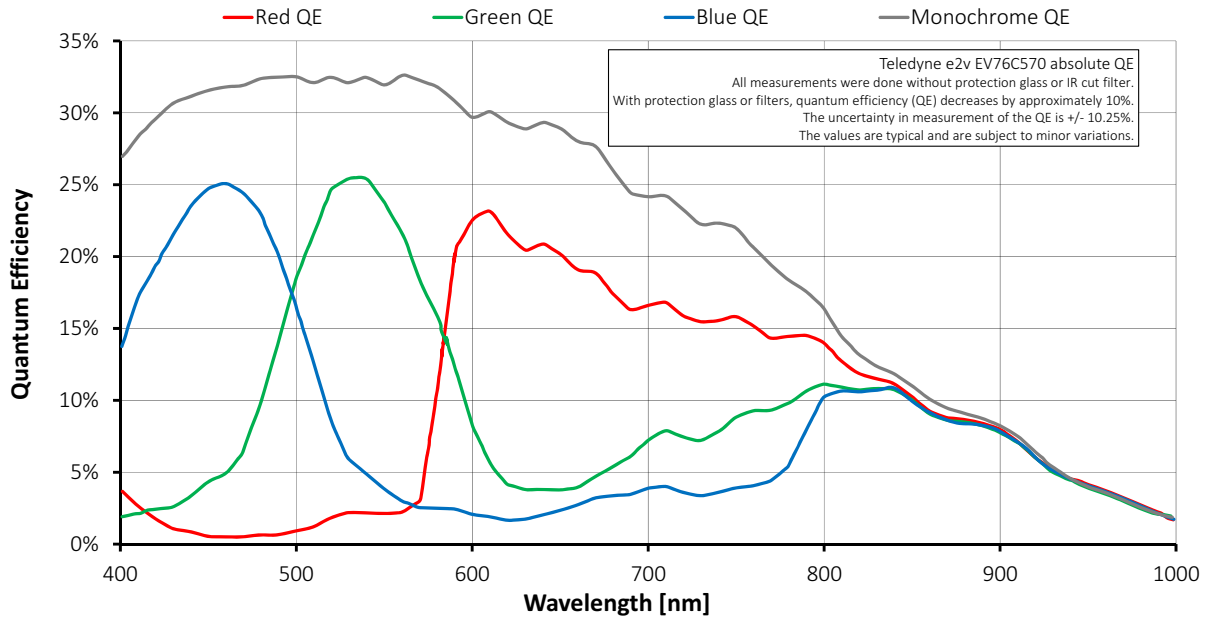

Figure 18: Mako G-192 (Teledyne e2v EV76C570) absolute QE

ROI frame rate

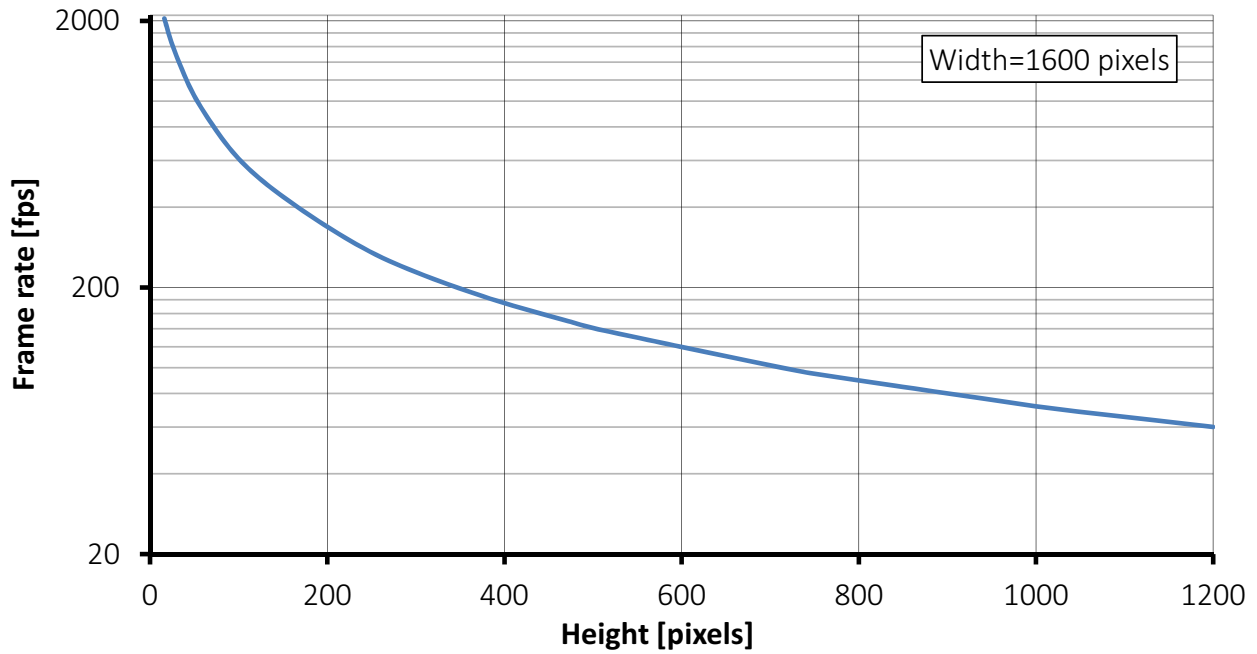

Figure 19: Mako G-192 frame rate as a function of ROI height

Height	Frame rate (fps)	Height	Frame rate (fps)
1200	60.0	360	193.0
1024	70.0	240	282.0
960	75.0	120	525.0
768	93.0	60	919.0
720	99.0	30	1470.0
512	138.0	16	2042.0
480	147.0		

Table 21: Frame rate as a function of ROI height (Width=1600 pixels)



There is an increase in frame rate with reduced width if the camera is bandwidth limited.

Mako G-223 series

The following table provides model series specifications. The values are valid for Mako G-223B, G-223B NIR, and G-223C models. For specifications common to all models, see [Specifications common to all models](#).

Feature	Specification	
	Mako G-223B, G-223B NIR	Mako G-223C
Sensor model	CMOSIS/ams CMV2000 with microlens	
Resolution (H × V)	2048 × 1088 2.2 MP	
Sensor type	CMOS	
Shutter type	Global	
Sensor format	Type 2/3	
Sensor size	12.7 mm diagonal	
Pixel size	5.5 μm × 5.5 μm	
Maximum frame rate at full resolution	49.5 fps	
Maximum image bit depth	12-bit	
Image buffer	64 MB	
StreamHoldCapacity	Up to 29 frames at full resolution	
Monochrome pixel formats	Mono8, Mono12Packed, Mono12	Mono8
YUV color pixel formats		YUV411Packed, YUV422Packed, YUV444Packed
RGB color pixel formats		RGB8Packed, BGR8Packed
RAW pixel formats		BayerGB8, BayerGB12, BayerGB12Packed
Exposure time control ¹	30 μs to 153 s; 1 μs increments	
Gain control	0 to 26 dB; 1 dB increments	
Power consumption	2.4 W at 12 VDC; 2.8 W PoE	
Trigger latency ²	3.205 μs	
Trigger jitter ²	±0.15 μs	
¹ Camera firmware version ≤ 01.52.8151 or later shows minimum exposure values without frame overhead time, that is, 1 μs. See the sensor data sheet for details on frame overhead time.		
² Trigger latency and trigger jitter values were measured at the external I/O (8-bit pixel format).		

Table 22: Mako G-223 model series specifications

Absolute QE

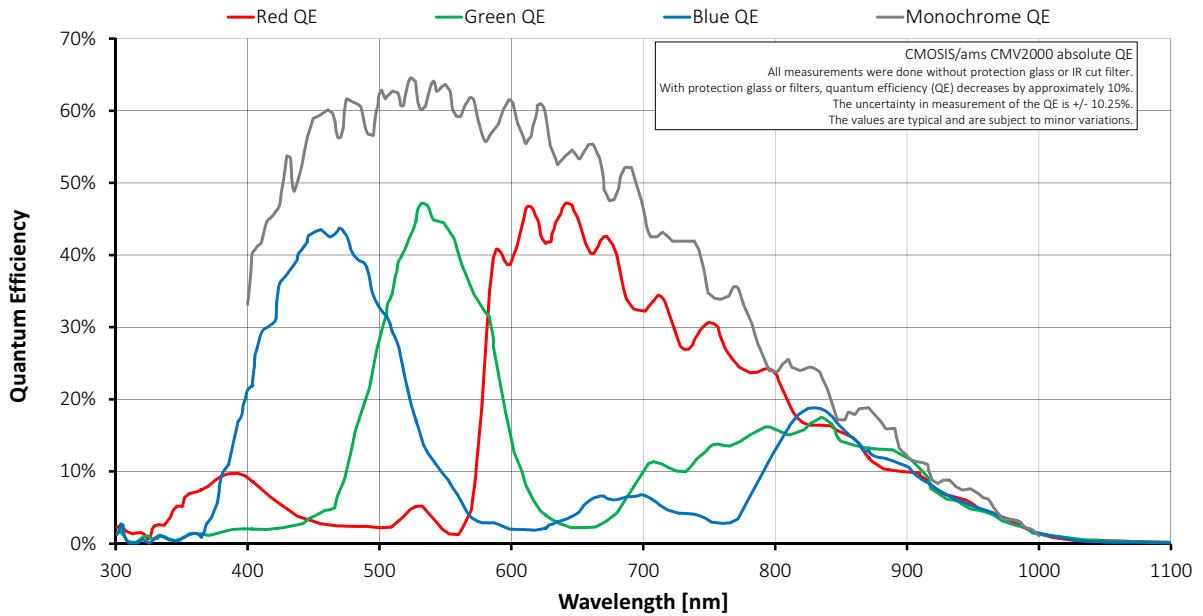

Figure 20: Mako G-223 (CMOSIS/ams CMV2000) absolute QE

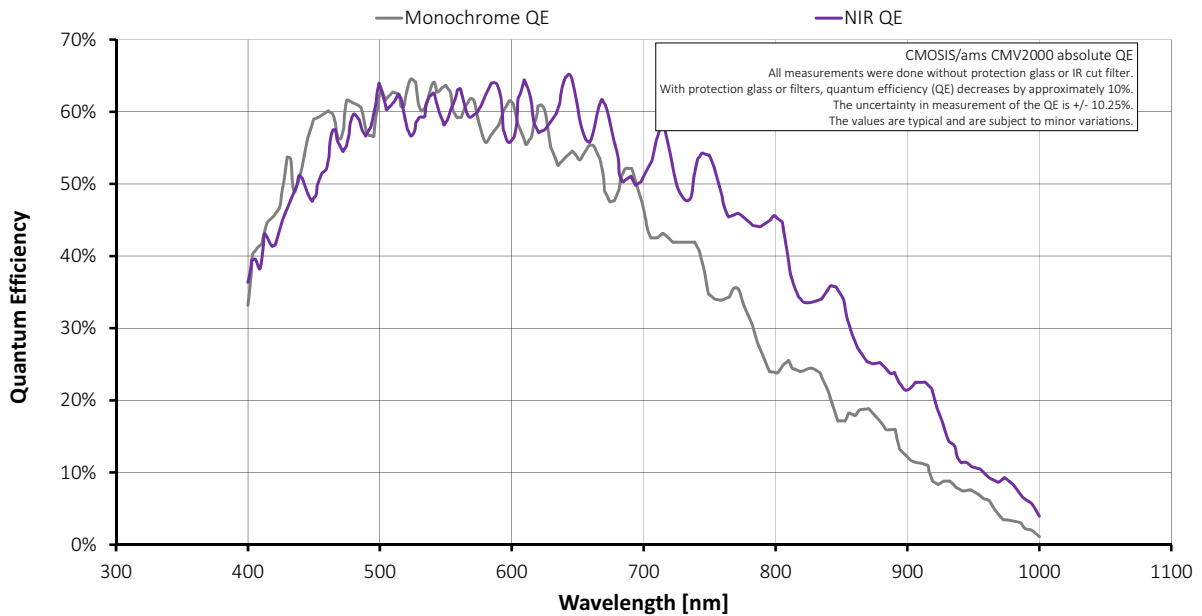

Figure 21: Mako G-223B NIR (CMOSIS/ams CMV2000) absolute QE

ROI frame rate

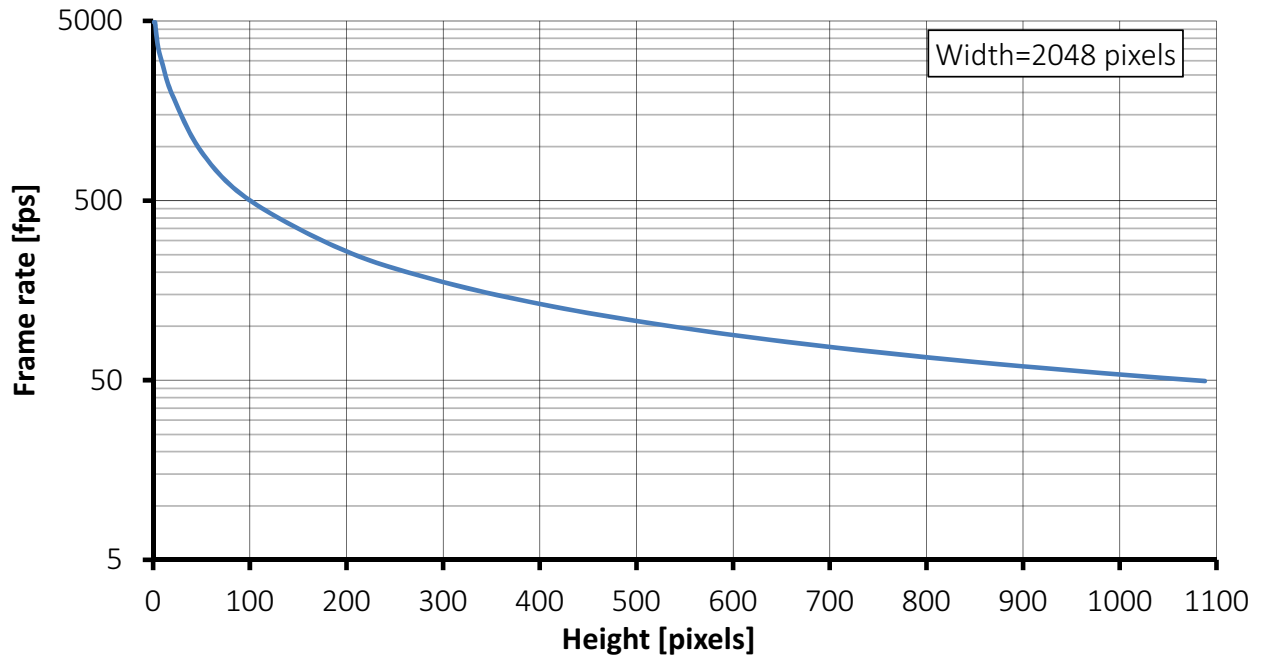

Figure 22: Mako G-223 frame rate as a function of ROI height

Height	Frame rate (fps)	Height	Frame rate (fps)
1088	49.5	200	260.8
1000	53.8	100	502.1
900	59.7	50	934.6
800	67.1	20	1933.8
700	76.6	10	2847.3
600	89.2	5	3624.5
500	106.8	2	4906.7
400	132.9	1	4926.1
300	176.1		

Table 23: Frame rate as a function of ROI height (Width=2048 pixels)



There is an increase in frame rate with reduced width if the camera is bandwidth limited.

Mako G-234 series

The following table provides model series specifications. The values are valid for Mako G-234B and G-234C models. For specifications common to all models, see [Specifications common to all models](#).

Feature	Specification	
	Mako G-234B	Mako G-234C
Sensor model	Sony IMX249LLJ Exmor	Sony IMX249LQJ Exmor
Resolution (H × V)	1936 × 1216 2.35 MP	
Sensor type	CMOS	
Shutter type	Pregius® global shutter	
Sensor format	Type 1/1.2	
Sensor size	13.4 mm diagonal	
Pixel size	5.86 μm × 5.86 μm	
Chief Ray Angle ¹	0.0°	
Sensor output	10-bit or 12-bit	
Maximum frame rate at full resolution	41.5 fps (10-bit) 32.3 fps (12-bit)	
Maximum image bit depth	12-bit	
Image buffer	64 MB	
StreamHoldCapacity	Up to 28 frames at full resolution	
Monochrome pixel formats	Mono8, Mono12Packed, Mono12	Mono8
YUV color pixel formats		YUV411Packed, YUV422Packed, YUV444Packed
RGB color pixel formats		RGB8Packed, BGR8Packed
RAW pixel formats		BayerRG8, BayerRG12, BayerRG12Packed
Exposure time control ²	Pixel format	Value
	Mono8, Mono12, Mono12Packed, BayerRG8, BayerRG12, BayerRG12Packed, YUV411Packed, YUV422Packed	32 μs to 71.6 s; 19.2 μs increments (10-bit) 38 μs to 85.9 s; 24.64 μs increments (12-bit)

Table 24: Mako G-234 model series specifications (sheet 1 of 2)

Feature	Specification	
	Mako G-234B	Mako G-234C
	RGB8Packed, BGR8Packed, YUV444Packed	52 μ s to 71.6 s; 38.4 μ s increments (10-bit) 63 μ s to 85.9 s; 49.28 μ s increments (12-bit)
Gain control	0 to 40 dB; 0.1 dB increments	
Binning	Horizontal: 1 to 4 pixels; Vertical: 1 to 4 rows	
Decimation	Horizontal and Vertical: 1, 2, 4, 8 factor	
Power consumption	2.4 W at 12 VDC; 2.8 W PoE	
Trigger latency ³	Pixel format	Value
	Mono8, BayerRG8, BayerRG12, BayerRG12Packed, YUV411Packed, YUV422Packed	57.6 μ s (10-bit), 73.92 μ s (12-bit)
	RGB8Packed, BGR8Packed, YUV444Packed	115.2 μ s (10-bit), 147.84 μ s (12-bit)
Trigger jitter ³	Pixel format	Value
	Mono8, BayerRG8, BayerRG12, BayerRG12Packed, YUV411Packed, YUV422Packed	\pm 9.6 μ s (10-bit), \pm 12.32 μ s (12-bit)
	RGB8Packed, BGR8Packed, YUV444Packed	\pm 19.2 μ s (10-bit), \pm 24.64 μ s (12-bit)
Time between exposures	Pixel format	Value
	Mono8, BayerRG8, BayerRG12, BayerRG12Packed, YUV411Packed, YUV422Packed	275 μ s (10-bit), 356 μ s (12-bit)
	RGB8Packed, BGR8Packed, YUV444Packed	563 μ s (10-bit), 726 μ s (12-bit)

¹ For more information on chief ray angle, contact Allied Vision support.

² Whenever pixel format is changed, Exposure adjusts itself to the nearest multiple of the exposure increment.

³ These values are calculated directly from the microcontroller source. There is no differentiation between Idle and Frame valid states for this sensor.

Table 24: Mako G-234 model series specifications (sheet 2 of 2)



With 10-bit sensor readout mode you can achieve a higher frame rate. The sensor is capable of higher frame rates but readout is limited by GigE bandwidth and exposure value. You can improve frame rates with a reduced ROI and shorter exposure values.

For more information on **SensorReadoutMode**, see the GigE Features Reference.

Absolute QE

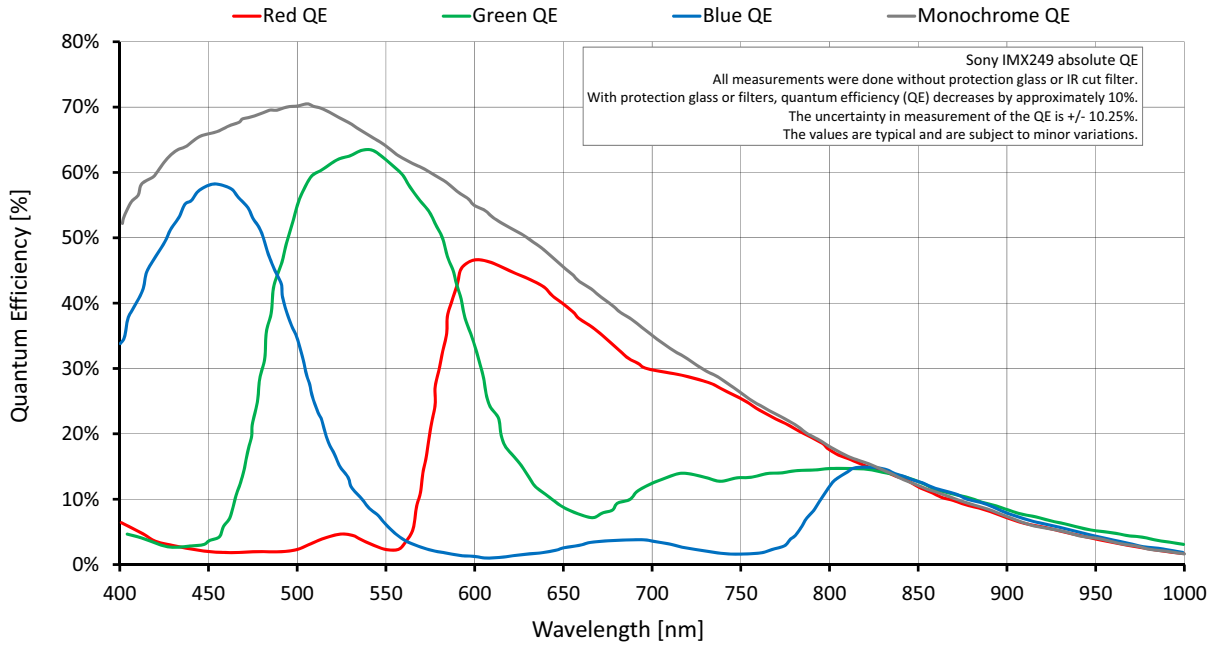

Figure 23: Mako G-234 (Sony IMX249) absolute QE

Spectral response

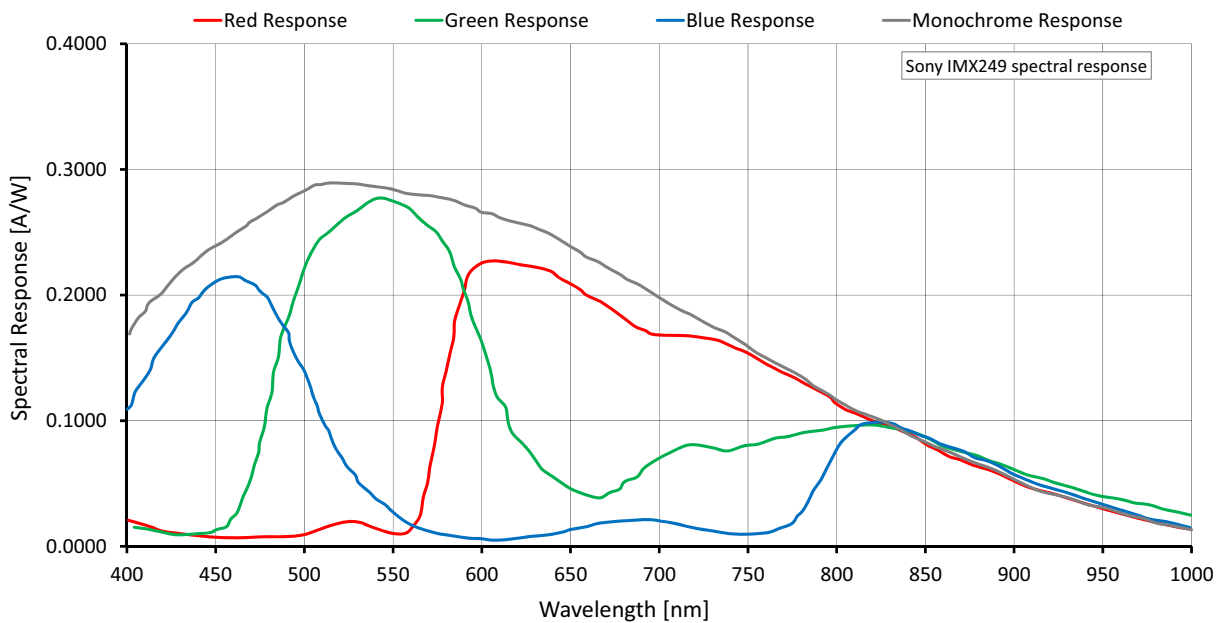

Figure 24: Mako G-234 (Sony IMX249) spectral response

ROI frame rate

12-bit sensor readout

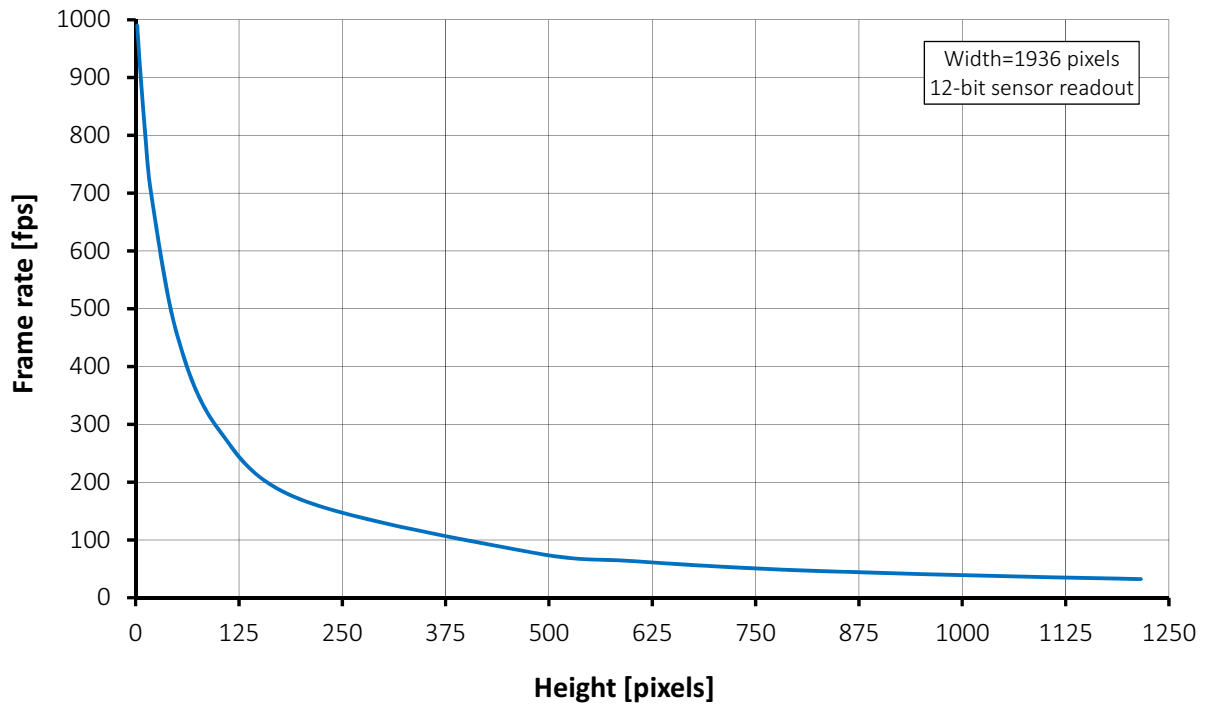

Figure 25: Mako G-234 12-bit sensor frame rate as a function of ROI height

Height	Frame rate (fps)	Height	Frame rate (fps)
1216	32.3	200	169.8
1080	36.3	100	292.0
1024	38.2	50	456.0
960	40.6	20	687.8
768	50.3	12	795.7
600	63.5	4	943.7
480	78.2	2	989.8

Table 25: Mako G-234 12-bit sensor frame rate as a function of ROI height (Width=1936 pixels)

10-bit sensor readout

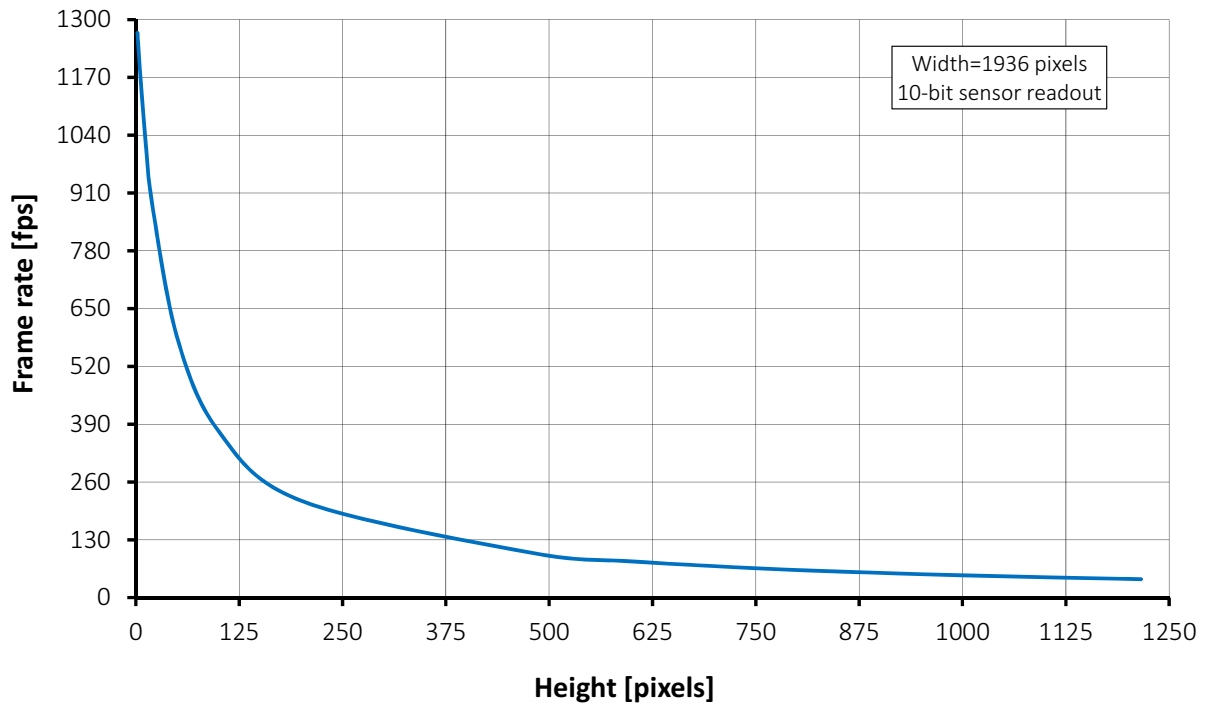

Figure 26: Mako G-234 10-bit sensor frame rate as a function of ROI height

Height	Frame rate (fps)	Height	Frame rate (fps)
1216	41.5	200	217.9
1080	46.5	100	374.7
1024	49.0	50	585.2
960	52.1	20	882.8
768	64.5	12	1021.2
600	81.5	4	1211.2
480	100.3	2	1270.3

Table 26: Mako G-234 10-bit sensor frame rate as a function of ROI height (Width=1936 pixels)

Mako G-319 series

The following table provides model series specifications. The values are valid for Mako G-319B and G-319C models. For specifications common to all models, see [Specifications common to all models](#).

Feature	Specification	
	Mako G-319B	Mako G-319C
Sensor model	Sony IMX265LLR Exmor	Sony IMX265LQR Exmor
Resolution (H × V)	2064 × 1544 3.2 MP	
Sensor type	CMOS	
Shutter type	Pregius® global shutter	
Sensor format	Type 1/1.8	
Sensor size	8.9 mm diagonal	
Pixel size	3.45 μm × 3.45 μm	
Chief ray angle ¹	0.0°	
Maximum frame rate at full resolution	37.6 fps (39.5 fps burst mode)	
Maximum image bit depth	12-bit	
Image buffer	64 MB	
StreamHoldCapacity	Up to 20 frames at full resolution	
Monochrome pixel formats	Mono8, Mono12Packed, Mono12	Mono8
YUV color pixel formats		YUV411Packed, YUV422Packed, YUV444Packed
RGB color pixel formats		RGB8Packed, BGR8Packed
RAW pixel formats		BayerRG8, BayerRG12, BayerRG12Packed
Exposure time control ²	Pixel format	Value
	Mono8, Mono12Packed, BayerRG8 BayerRG12Packed, YUV411Packed	29 μs to 85.9 s; 16 μs increments
	Mono12, BayerRG12, YUV422Packed	35 μs to 85.9 s; 21.28 μs increments
	RGB8Packed, BGR8Packed, YUV444Packed	45 μs to 85.9 s; 32 μs increments
Gain control	0 to 40 dB; 0.1 dB increments	

Table 27: Mako G-319 model series specifications (sheet 1 of 2)

Feature	Specification	
	Mako G-319B	Mako G-319C
Binning	Horizontal: 1 to 4 pixels Vertical: 1 to 4 rows	Horizontal: 1 to 4 pixels
Decimation	Horizontal and Vertical: 1, 2, 4, 8 factor	
Power consumption	2.5 W at 12 VDC; 2.7 W PoE	
Trigger latency ³	Pixel format	Value
	Mono8, Mono12Packed, BayerRG8 BayerRG12Packed, YUV411Packed	48 μ s
	Mono12, BayerRG12, YUV422Packed	63.84 μ s
	RGB8Packed, BGR8Packed, YUV444Packed	96 μ s
Trigger jitter ³	Pixel format	Value
	Mono8, Mono12Packed, BayerRG8 BayerRG12Packed, YUV411Packed	\pm 8 μ s
	Mono12, BayerRG12, YUV422Packed	\pm 10.64 μ s
	RGB8Packed, BGR8Packed, YUV444Packed	\pm 16 μ s
Time between exposures	Pixel format	Value
	Mono8, Mono12Packed, BayerRG8 BayerRG12Packed, YUV411Packed	227 μ s
	Mono12, BayerRG12, YUV422Packed	306 μ s
	RGB8Packed, BGR8Packed, YUV444Packed	467 μ s

¹ For more information on chief ray angle, contact Allied Vision support.

² Whenever **PixelFormat** is changed, exposure adjusts itself to the nearest multiple of the exposure increment.

³ These values are calculated directly from the microcontroller source. There is no differentiation between Idle and Frame valid states for this sensor.

Table 27: Mako G-319 model series specifications (sheet 2 of 2)

Absolute QE

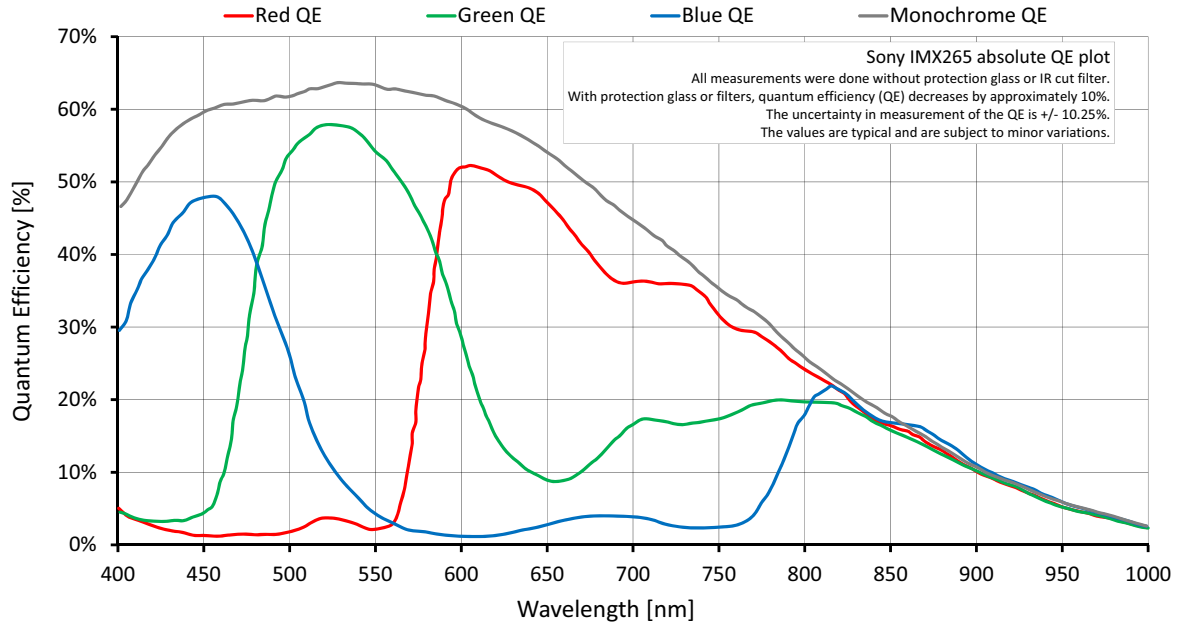

Figure 27: Mako G-319 (Sony IMX265) absolute QE

Spectral response

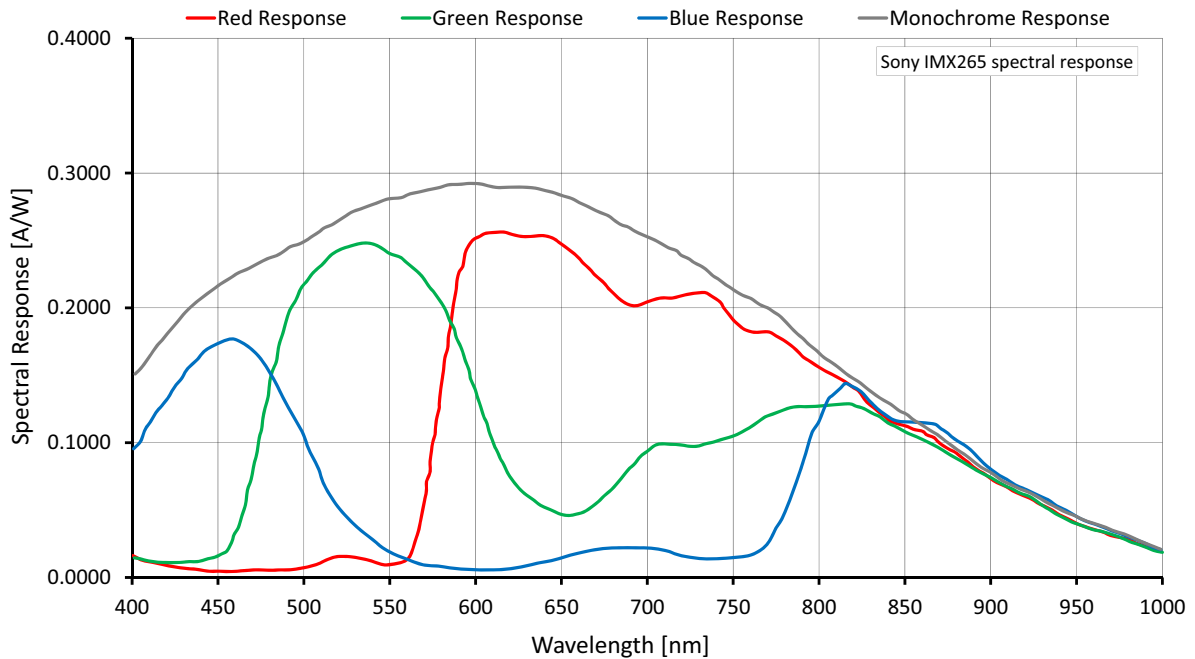

Figure 28: Mako G-319 (Sony IMX265) spectral response

ROI frame rate

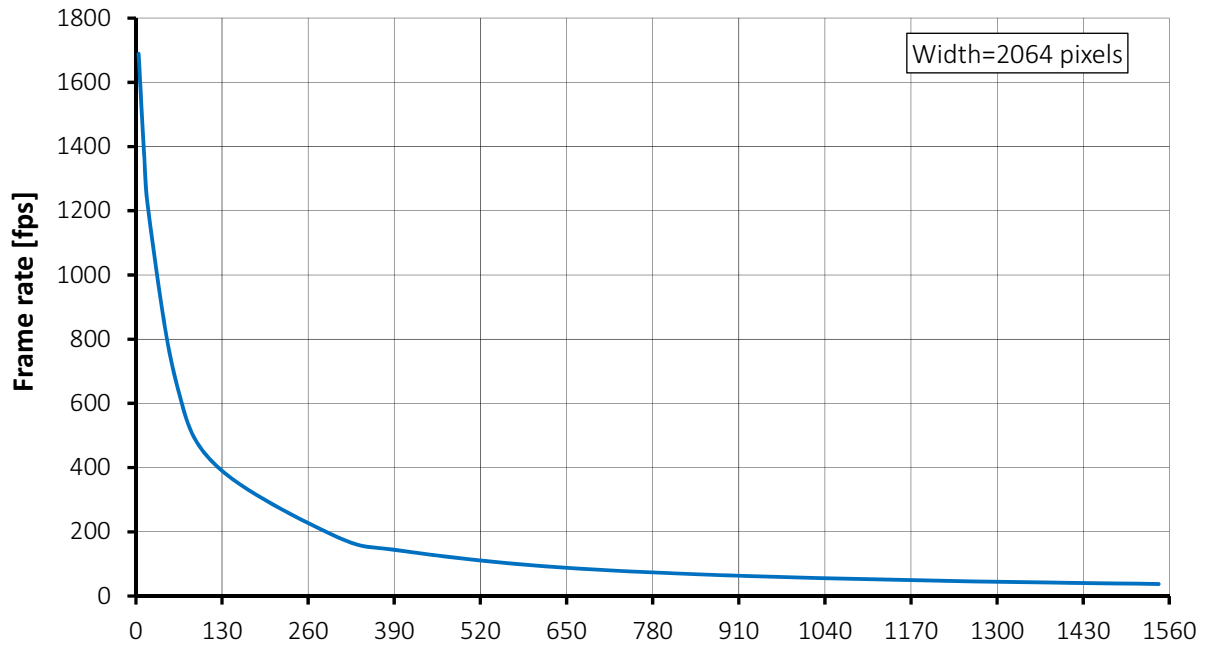

Figure 29: Mako G-319 frame rate as a function of ROI height

Height	Frame rate (fps)	Height	Frame rate (fps)
1544	37.6	300	187.7
1280	45.2	120	408.5
1024	56.5	60	672.0
800	71.9	20	1179.2
600	95.4	12	1388.9
400	141.4	4	1689.2

Table 28: Frame rate as a function of ROI height (Width=2064 pixels)



There is an increase in frame rate with reduced width if the camera is bandwidth limited. Reducing the exposure time may result in higher frame rates.

Mako G-419 series

The following table provides model series specifications. The values are valid for Mako G-419B, G-419B NIR, and G-419C models. For specifications common to all models, see [Specifications common to all models](#).

Feature	Specification	
	Mako G-419B, G-419B NIR	Mako G-419C
Sensor model	CMOSIS/ams CMV4000	
Resolution (H × V)	2048 × 2048 4.2 MP	
Sensor type	CMOS	
Shutter type	Global	
Sensor format	Type 1	
Sensor size	16.0 mm diagonal	
Pixel size	5.5 μm × 5.5 μm	
Maximum frame rate at full resolution	26.3 fps	
Maximum image bit depth	12-bit	
Image buffer	64 MB	
StreamHoldCapacity	Up to 15 frames at full resolution	
Monochrome pixel formats	Mono8, Mono12Packed, Mono12	Mono8
YUV color pixel formats		YUV411Packed, YUV422Packed, YUV444Packed
RGB color pixel formats		RGB8Packed, BGR8Packed
RAW pixel formats		BayerGB8, BayerGB12, BayerGB12Packed
Exposure time control ¹	41 μs to 153 s; 1 μs increments	
Gain control	0 to 26 dB; 1 dB increments	
Power consumption	2.3 W at 12 VDC; 2.7 W PoE	
Trigger latency	3.48 μs	
Trigger jitter	±0.15 μs	
¹ Camera firmware version ≤ 01.52.8151 shows minimum exposure values without frame overhead time; 1 μs. See the sensor data sheet for details on frame overhead time.		
² Trigger latency and trigger jitter values were measured at the external I/O (8-bit pixel format).		

Table 29: Mako G-419 model series specifications

Absolute QE

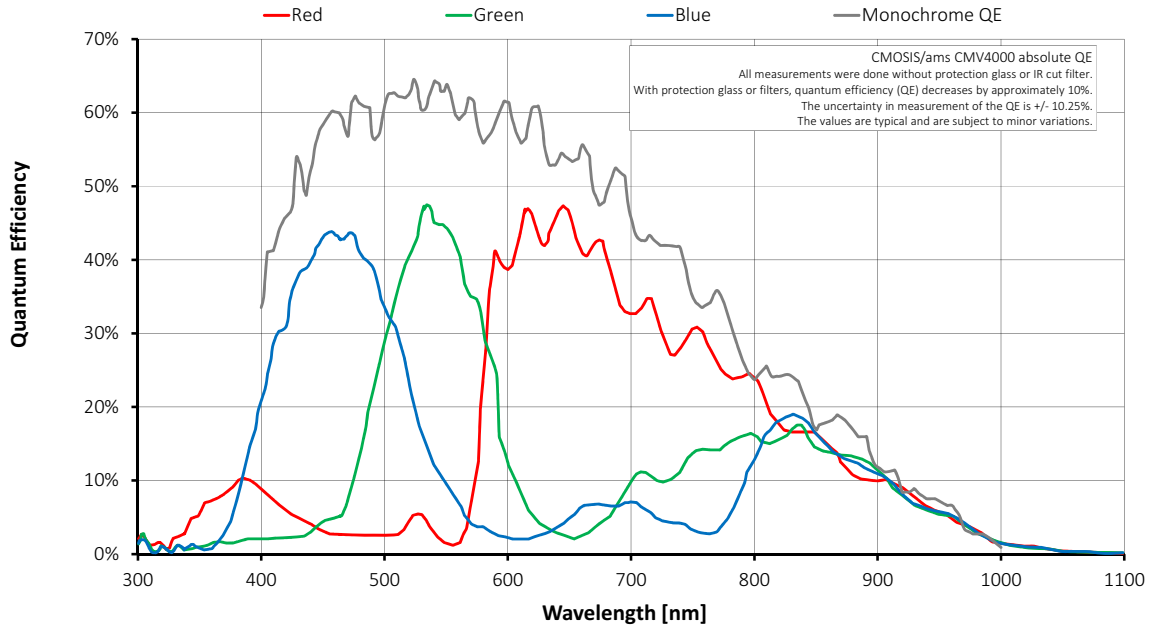

Figure 30: Mako G-419 (CMOSIS/ams CMV4000) absolute QE

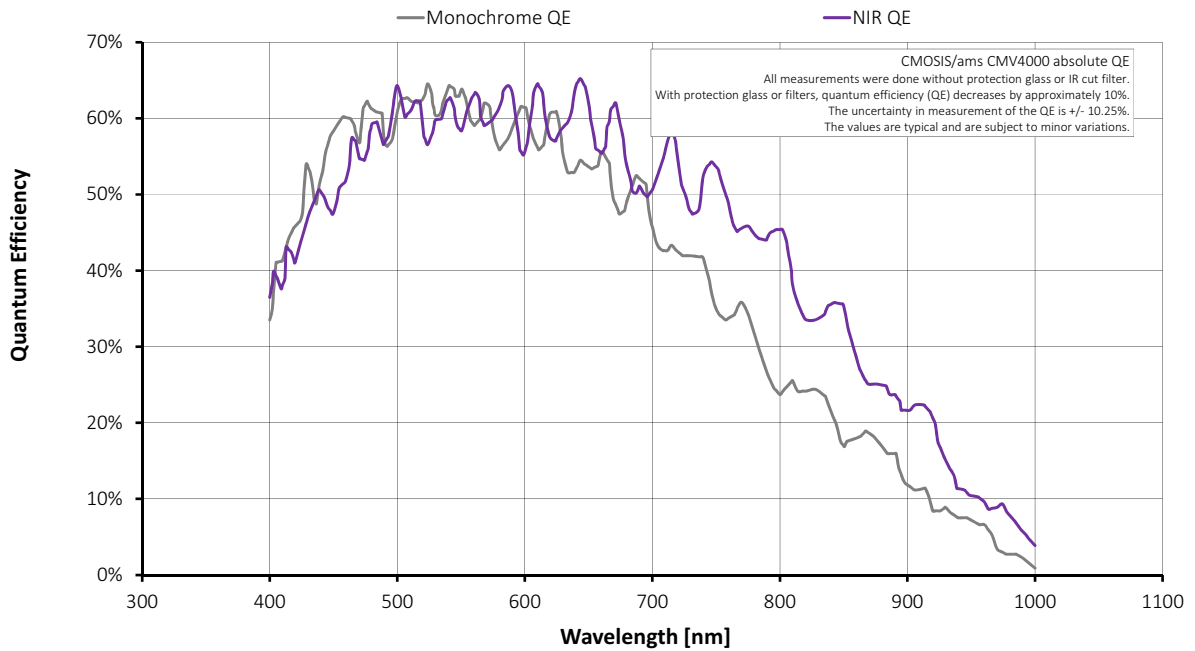

Figure 31: Mako G-419B NIR (CMOSIS/ams CMV4000) absolute QE

ROI frame rate

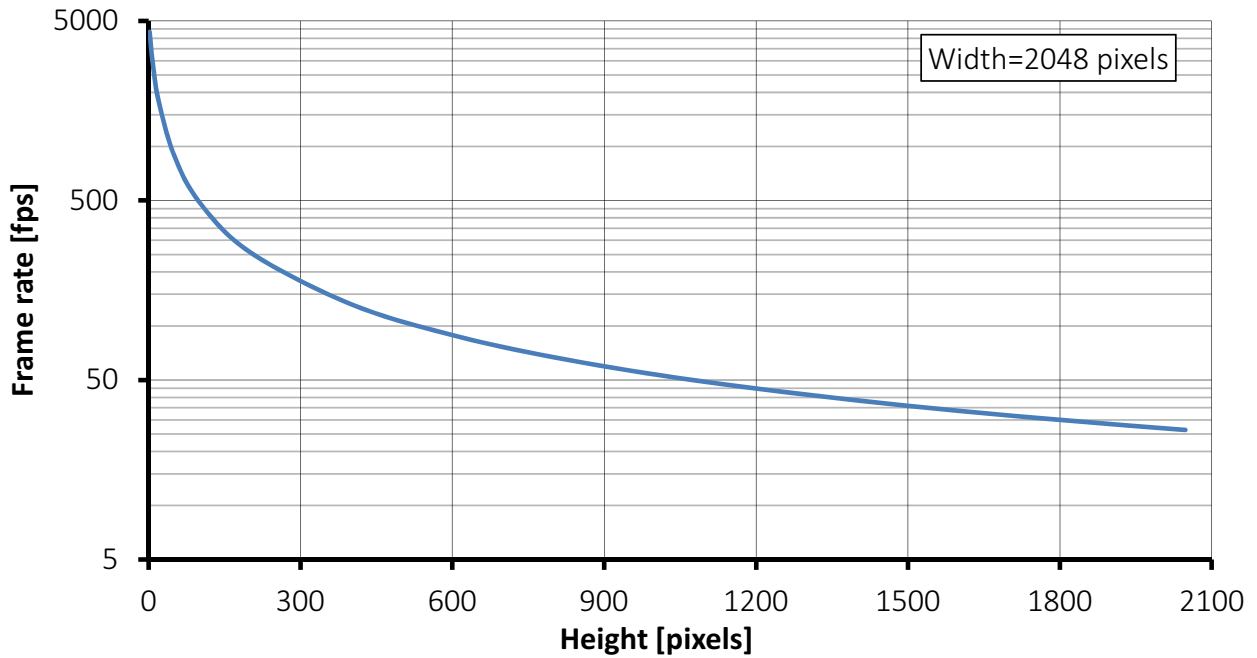

Figure 32: Mako G-419 frame rate as a function of ROI height

Height	Frame rate (fps)	Height	Frame rate (fps)
2048	26.3	400	132.1
2000	26.9	200	257.7
1800	29.9	100	490.8
1600	33.6	50	895.9
1400	38.4	20	1775.5
1200	44.8	10	2639.2
1000	53.7	5	3486.7
800	66.9	2	4342.1
600	88.8		

Table 30: Frame rate as a function of ROI height (Width=2048 pixels)



There is an increase in frame rate with reduced width if the camera is bandwidth limited.

Mako G-503 series

The following table provides model series specifications. The values are valid for Mako G-503B and G-503C models. For specifications common to all models, see [Specifications common to all models](#).

Feature	Specification	
	Mako G-503B	Mako G-503C
Sensor model	ON Semi MT9P031	ON Semi MT9P006
Resolution (H × V)	2592 × 1944 5.0 MP	
Sensor type	CMOS	
Shutter type	Global Reset, Rolling	
Sensor format	Type 1/2.5	
Sensor size	7.13 mm diagonal	
Pixel size	2.2 μm × 2.2 μm	
Chief ray angle ¹	7°	7°, 27°
Maximum frame rate at full resolution	14 fps	
Maximum image bit depth	12-bit	
Image buffer	64 MB	
StreamHoldCapacity	Up to 13 frames at full resolution	
Monochrome pixel formats	Mono8, Mono12, Mono12Packed	Mono8
YUV color pixel formats		YUV411Packed, YUV422Packed, YUV444Packed
RGB color pixel formats		RGB8Packed, BGR8Packed
RAW pixel formats		BayerGR8, BayerGR12Packed, BayerGR12
Exposure time control ²	31 μs to 1 s; 36.4 μs increments	
Gain control	0 to 24 dB; 1 dB increments	
Binning ³	Horizontal: 1 to 4 pixels; Vertical: 1 to 4 rows	
Decimation	Horizontal and Vertical: 1, 2, 4 factor	
Power consumption	2.0 W at 12 VDC; 2.2 W PoE	
Trigger latency ⁴	Idle state: 73.4 μs; Frame valid state: 73.4 μs	

Table 31: Mako G-503 model series specifications (sheet 1 of 2)

Feature	Specification	
	Mako G-503B	Mako G-503C
Trigger jitter ⁴	Idle state: $\pm 18.4 \mu\text{s}$; Frame valid state: $\pm 18.4 \mu\text{s}$	

¹ For more information on chief ray angle, contact Allied Vision support.

² These exposure time control values are only valid with factory default settings. Exposure time control values vary depending upon pixel format and width.

³ Mako G-503 supports **BinningHorizontalMode = Sum or Average** and **BinningVerticalMode = Sum or Average**.

⁴ These values are calculated directly from the microcontroller source. These values are only valid for pixel formats < 16 bits per pixel and applicable in both Idle and Frame valid states:

- Idle state: sensor is ready and camera is idle, waiting for the next trigger.
- Frame valid state: sensor is reading out and camera is busy. If next frame is requested by an external trigger in this state, higher latency may occur as compared to the Idle state.

Table 31: Mako G-503 model series specifications (sheet 2 of 2)

Absolute QE

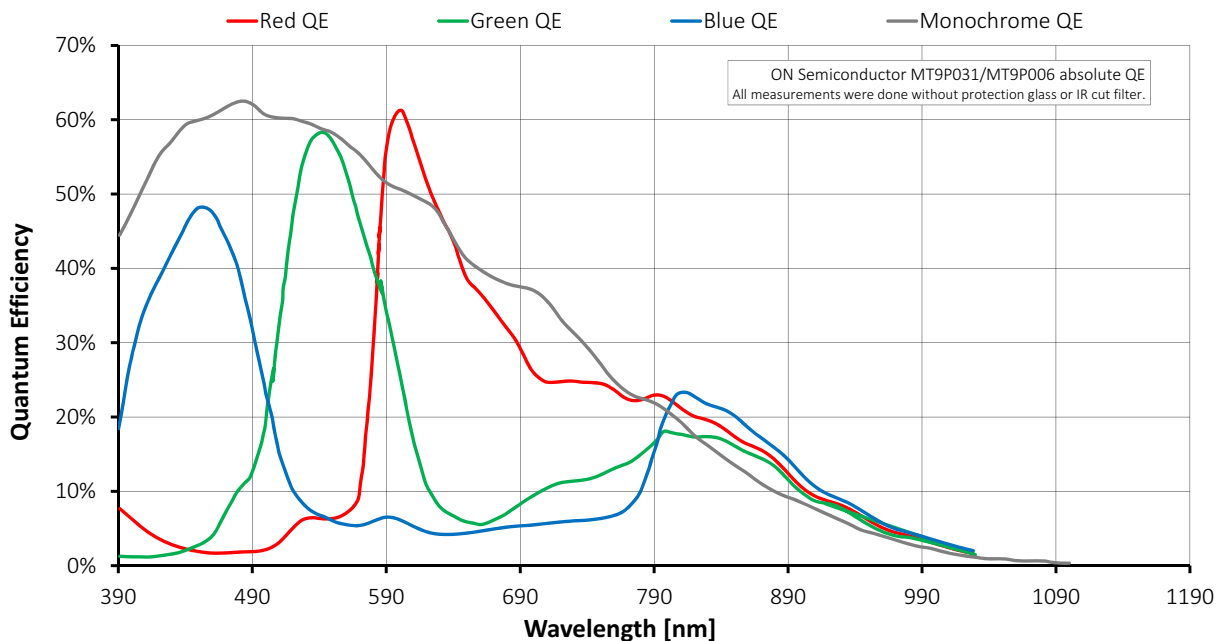

Figure 33: Mako G-503 (ON Semi MT9P031/MT9P006) absolute QE

ROI frame rate

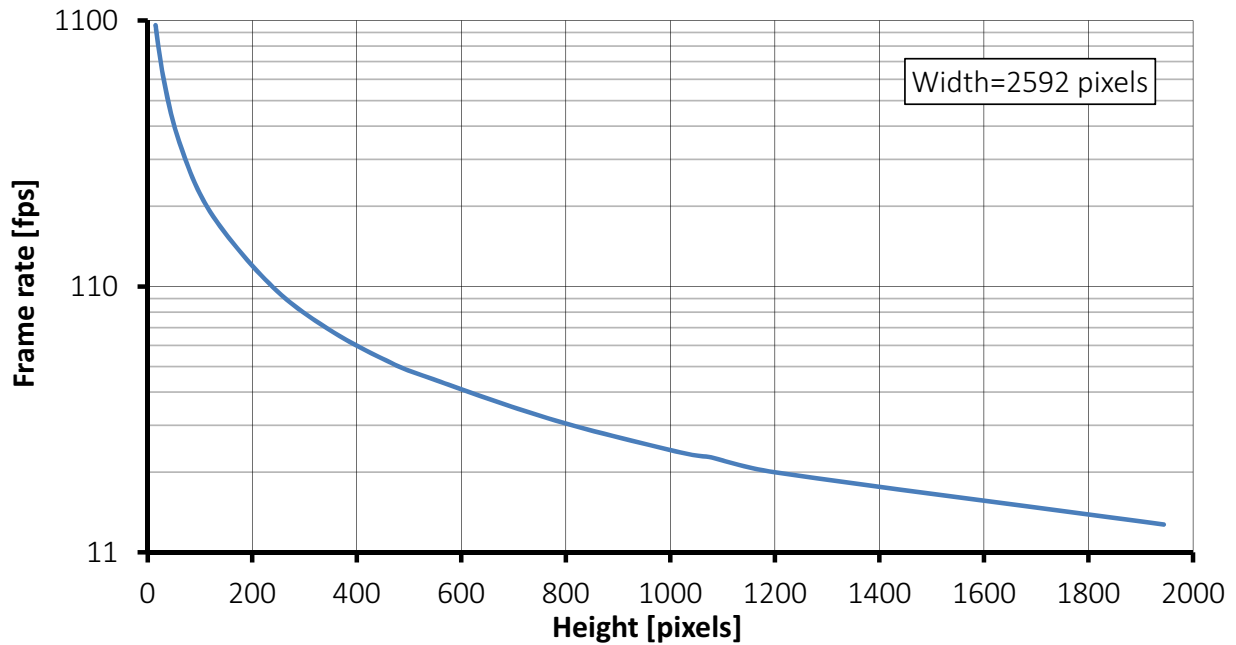

Figure 34: Mako G-503 frame rate as a function of ROI height

Height	Frame rate (fps)	Height	Frame rate (fps)
1944	14.0	360	73.0
1200	22.0	240	109.0
1080	25.0	120	209.0
1024	26.0	60	386.0
768	35.0	30	669.0
512	52.0	15	1055.0
480	55.0		

Table 32: Frame rate as a function of ROI height (Width=2592 pixels)



There is an increase in frame rate with reduced width if the camera is bandwidth limited.

Mako G-507 series

The following table provides model series specifications. The values are valid for Mako G-507B and G-507C models. For specifications common to all models, see [Specifications common to all models](#).

Feature	Specification	
	Mako G-507B	Mako G-507C
Sensor model	Sony IMX264LLR Exmor	Sony IMX264LQR Exmor
Resolution (H × V)	2464 × 2056 5.1 MP	
Sensor type	CMOS	
Shutter type	Pregius® global shutter	
Sensor format	Type 2/3	
Sensor size	11.1 mm diagonal	
Pixel size	3.45 μm × 3.45 μm	
Chief ray angle ¹	0.0°	
Maximum frame rate at full resolution	23.7 fps (25.3 fps burst mode)	
Maximum image bit depth	12-bit	
Image buffer	64 MB	
StreamHoldCapacity	Up to 13 frames at full resolution	
Monochrome pixel formats	Mono8, Mono12Packed, Mono12	Mono8
YUV color pixel formats		YUV411Packed, YUV422Packed, YUV444Packed
RGB color pixel formats		RGB8Packed, BGR8Packed
RAW pixel formats		BayerRG8, BayerRG12, BayerRG12Packed
Exposure time control ²	Pixel format	Value
	Mono8, Mono12Packed, BayerRG8 BayerRG12Packed, YUV411Packed	32 μs to 85.9 s; 18.88 μs increments
	Mono12, BayerRG12, YUV422Packed	38 μs to 85.9 s; 25.12 μs increments
	RGB8Packed, BGR8Packed, YUV444Packed	51 μs to 85.9 s; 37.76 μs increments
Gain control	0 to 40 dB; 0.1 dB increments	

Table 33: Mako G-507 model series specifications (sheet 1 of 2)

Feature	Specification	
	Mako G-507B	Mako G-507C
Binning	Horizontal: 1 to 4 pixels; Vertical: 1 to 4 rows	
Decimation	Horizontal and Vertical: 1, 2, 4, 8 factor	
Power consumption	2.4 W at 12 VDC; 2.8 W PoE	
Trigger latency ³	Pixel format	Value
	Mono8, Mono12Packed, BayerRG8 BayerRG12Packed, YUV411Packed	56.64 μ s
	Mono12, BayerRG12, YUV422Packed	75.36 μ s
	RGB8Packed, BGR8Packed, YUV444Packed	113.28 μ s
Trigger jitter ³	Pixel format	Value
	Mono8, Mono12Packed, BayerRG8 BayerRG12Packed, YUV411Packed	\pm 9.44 μ s
	Mono12, BayerRG12, YUV422Packed	\pm 12.56 μ s
	RGB8Packed, BGR8Packed, YUV444Packed	\pm 18.88 μ s
Time between exposures	Pixel format	Value
	Mono8, Mono12Packed, BayerRG8 BayerRG12Packed, YUV411Packed	270 μ s
	Mono12, BayerRG12, YUV422Packed	363 μ s
	RGB8Packed, BGR8Packed, YUV444Packed	554 μ s

¹ For more information on chief ray angle, contact Allied Vision support.

² Whenever pixel format is changed, exposure adjusts itself to the nearest multiple of the exposure increment.

³ These values are calculated directly from the microcontroller source. There is no differentiation between Idle and Frame valid states for this sensor.

Table 33: Mako G-507 model series specifications (sheet 2 of 2)

Absolute QE

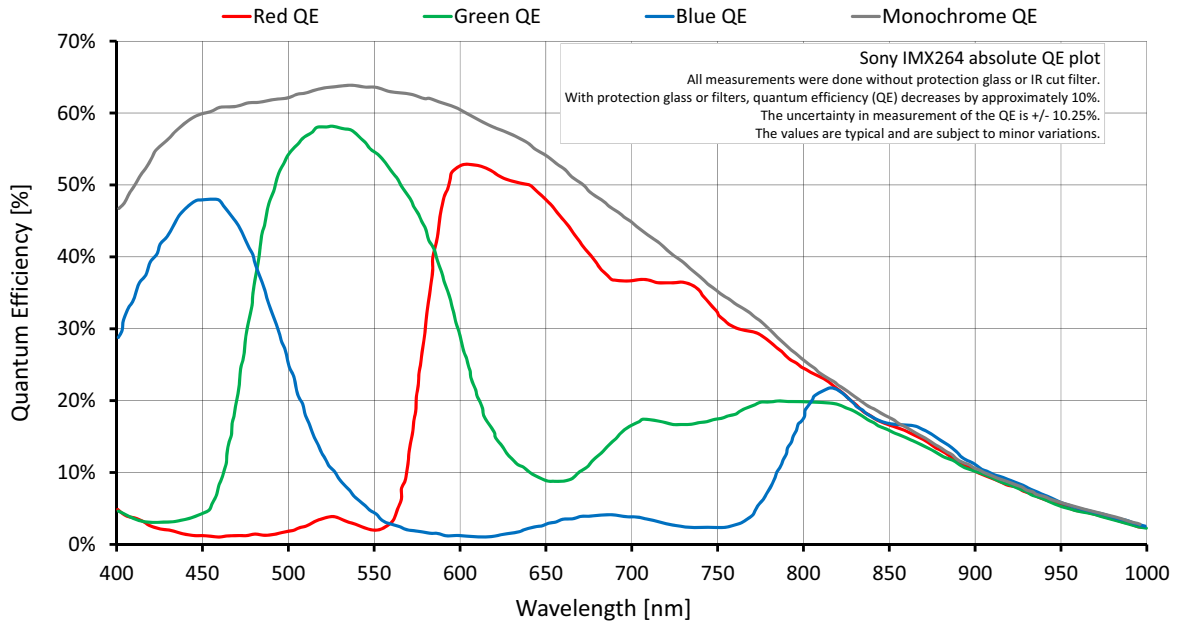

Figure 35: Mako G-507 (Sony IMX264) absolute QE

Spectral response

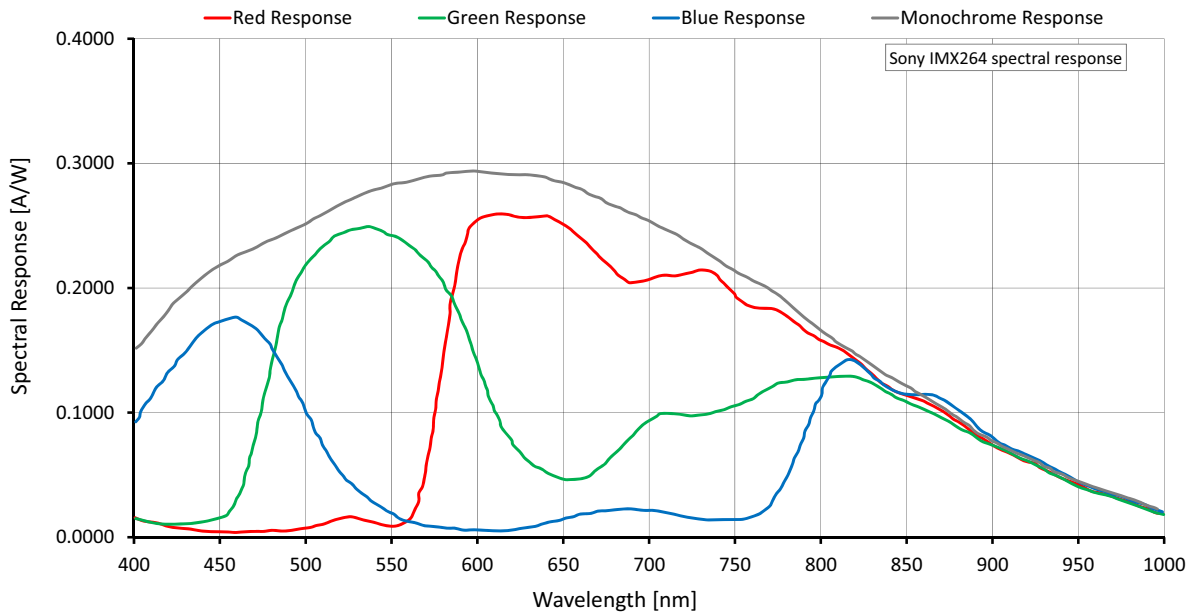

Figure 36: Mako G-507 (Sony IMX264) spectral response

ROI frame rate

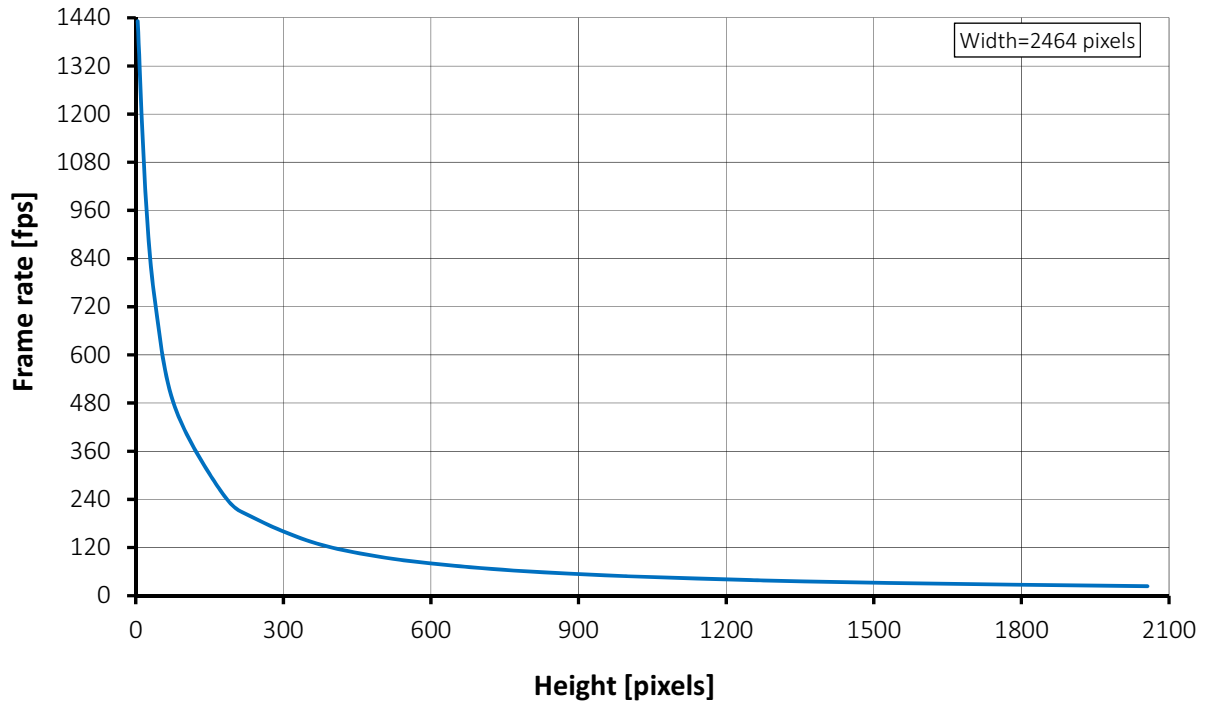

Figure 37: Mako G-507 frame rate as a function of ROI height

Height	Frame rate (fps)	Height	Frame rate (fps)
2056	23.7	480	100.3
1544	31.5	360	133.0
1324	36.8	240	194.0
1280	38.0	180	248.7
1024	47.4	80	468.7
960	50.6	40	725.5
768	62.9	20	999.3
600	80.6	4	1431.4

Table 34: Frame rate as a function of ROI height (Width=2464 pixels)



There is an increase in frame rate with reduced width if the camera is bandwidth limited. Reducing the exposure time may result in higher frame rates.

Mako G-508B POL

The following table provides model specifications for Mako G-508B POL. For specifications common to all models, see [Specifications common to all models](#).

Feature	Specification	
Sensor model	Sony IMX250MZR Polarsens	
Resolution (H × V)	2464 × 2056 5.0 MP	
Sensor type	CMOS	
Shutter type	Pregius® global shutter	
Sensor format	Type 2/3	
Sensor size	11.1 mm diagonal	
Pixel size	3.45 μm × 3.45 μm	
Chief ray angle ¹	0.0°	
Maximum frame rate at full resolution	23.7 fps (25.3 fps burst mode)	
Maximum image bit depth	12-bit	
Image buffer	64 MB	
StreamHoldCapacity	Up to 13 frames at full resolution	
Monochrome pixel formats	Mono8, Mono12Packed, Mono12	
Exposure time control ²	Pixel format	Value
	Mono8, Mono12Packed	32 μs to 85.9 s; 18.88 μs increments
	Mono12	38 μs to 85.9 s; 25.12 μs increments
Gain control	0 to 40 dB; 0.1 dB increments	
Binning	Horizontal: 1 to 4 pixels; Vertical: 1 to 4 rows	
Decimation	Horizontal and Vertical: 1, 2, 4, 8 factor	
Power consumption	2.4 W at 12 VDC; 2.8 W PoE	
Trigger latency ³	Pixel format	Value
	Mono8, Mono12Packed	56.64 μs
	Mono12	75.36 μs
Trigger jitter ³	Pixel format	Value
	Mono8, Mono12Packed	±9.44 μs
	Mono12	±12.56 μs

Table 35: Mako G-508B POL model series specifications (sheet 1 of 2)

Feature	Specification	
Time between exposures	Pixel format	Value
	Mono8, Mono12Packed	270 μ s
	Mono12	363 μ s

¹ For more information on chief ray angle, contact Allied Vision support.

² Whenever pixel format is changed, exposure adjusts itself to the nearest multiple of the exposure increment.

³ These values are calculated directly from the microcontroller source. There is no differentiation between Idle and Frame valid states for this sensor.

Table 35: Mako G-508B POL model series specifications (sheet 2 of 2)

Absolute QE

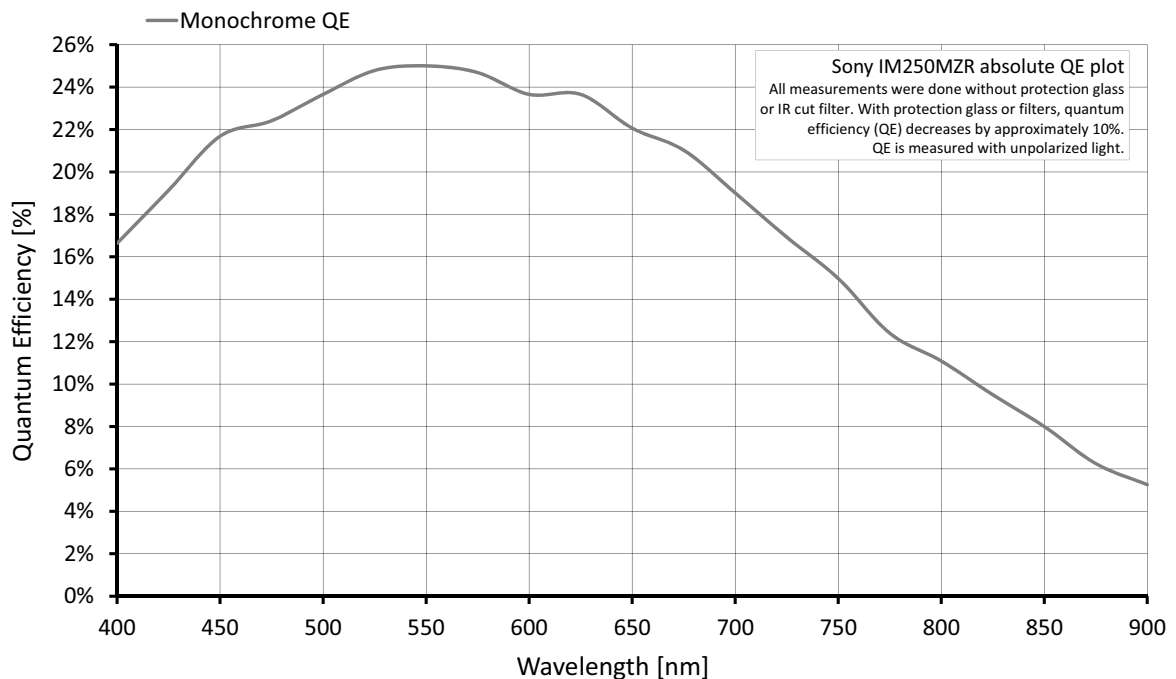

Figure 38: Mako G-508B POL (Sony IMX250MZR) absolute QE

Polarization coding diagram

The four-directional polarization of the Sony IMX250MZR sensor is arranged to get transmitted light in the layout shown in the figure below. The 90° signal and 45° signal lines and the 135° signal and 0° signal lines are output successively.

90	45	90	45
135	0	135	0
90	45	90	45
135	0	135	0

Polarization Coding Diagram

Figure 39: Polarization coding of physical pixel array

ROI frame rate

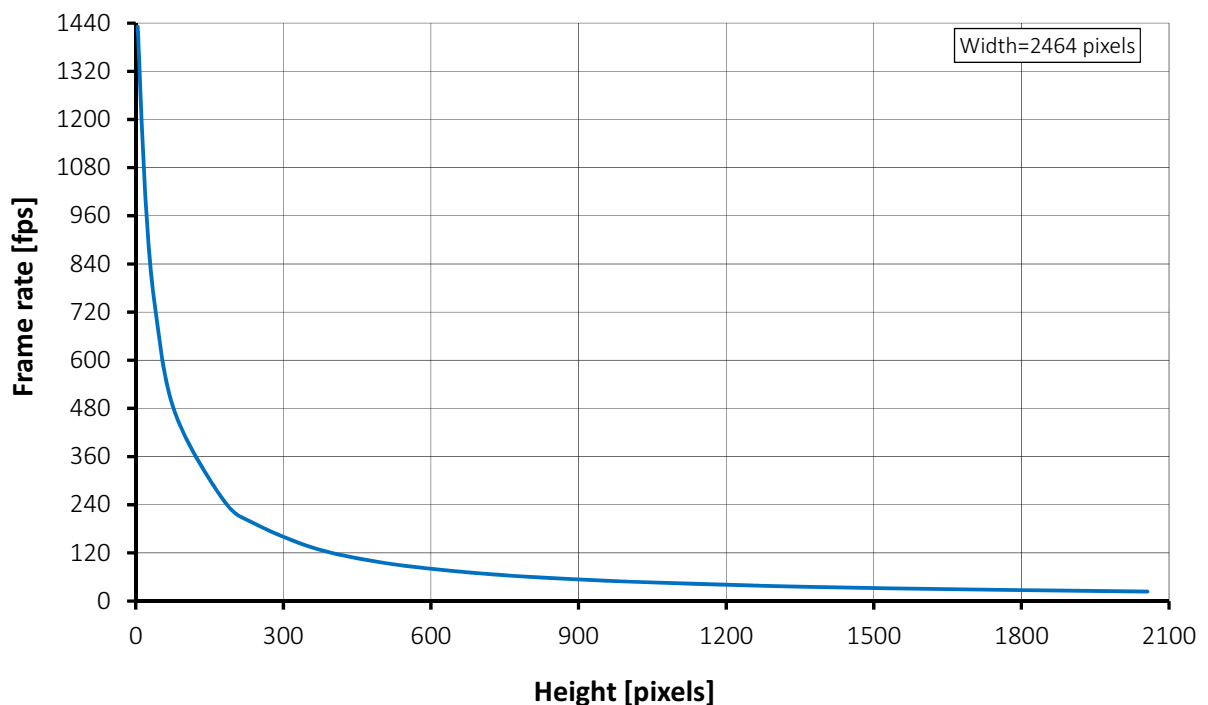

Figure 40: Mako G-508B POL frame rate as a function of ROI height

Height	Frame rate (fps)	Height	Frame rate (fps)
2056	23.7	480	100.3
1544	31.5	360	133.0
1324	36.8	240	194.0
1280	38.0	180	248.7
1024	47.4	80	468.7
960	50.6	40	725.5
768	62.9	20	999.3
600	80.6	4	1431.4

Table 36: Frame rate as a function of ROI height (Width=2464 pixels)



There is an increase in frame rate with reduced width if the camera is bandwidth limited. Reducing the exposure time may result in higher frame rates.

Camera feature comparison

Mako G cameras support a number of standard and extended features. The following table identifies a selection of capabilities and compares the availability of features in Mako G camera models.

A complete listing of camera features, including definitions can be found on the Allied Vision Technical Documentation webpage.

- Vimba and third-party users: GigE Features Reference
- PvAPI users: GigE Camera and Driver Attributes document

Image optimization features	Mako G-030	Mako G-032	Mako G-040	Mako G-125	Mako G-131	Mako G-158	Mako G-192	Mako G-223	Mako G-234	Mako G-319	Mako G-419	Mako G-503	Mako G-507	Mako G-508
Auto gain	✓	✓	✓	✓	✓	✓	✓	✓	✓	✓	✓	✓	✓	✓
Auto exposure	✓	✓	✓	✓	✓	✓	✓	✓	✓	✓	✓	✓	✓	✓
Auto white balance ¹	✓	✓	✓	✓	✓	✓	✓	✓	✓	✓	✓	✓	✓	
BinningHorizontal		✓	✓	✓	✓	✓	✓		✓	✓		✓	✓	✓
BinningVertical		✓	✓	✓	✓	✓	✓		✓	✓ ²		✓	✓ ²	✓ ²
Black level (offset)	✓	✓	✓	✓	✓	✓	✓	✓	✓	✓	✓	✓	✓	✓
Decimation	✓		✓		✓	✓	✓		✓	✓		✓	✓	✓
Defect masking	✓				✓		✓	✓			✓	✓		
Gamma correction	✓	✓	✓	✓	✓	✓	✓	✓	✓	✓	✓	✓	✓	✓
Hue, saturation, color transformation ¹	✓	✓	✓	✓	✓	✓	✓	✓	✓	✓	✓	✓	✓	
One look-up table	✓	✓	✓	✓	✓	✓	✓	✓	✓	✓	✓	✓	✓	✓
Region of interest	✓	✓	✓	✓	✓	✓	✓	✓	✓	✓	✓	✓	✓	✓
Piecewise linear HDR mode	✓							✓			✓			
Reverse X/Y	✓		✓		✓	✓	✓		✓	✓		✓	✓	✓
Sensor shutter mode ³	2	2	2	2	1	2	1	2	2	2	2	3	2	2
¹ Color models only														
² Monochrome models only														
³ Sensor shutter mode: (1) Global, Rolling, Global Reset, (2) Global, (3) Global Reset, Rolling														

Table 37: Image optimization feature comparison by model

Camera control features	Mako G-030	Mako G-032	Mako G-040	Mako G-125	Mako G-131	Mako G-158	Mako G-192	Mako G-223	Mako G-234	Mako G-319	Mako G-419	Mako G-503	Mako G-507	Mako G-508
10/12 bit sensor output mode									✓					
Event channel	✓	✓	✓	✓	✓	✓	✓	✓	✓	✓	✓	✓	✓	✓
Image chunk data	✓	✓	✓	✓	✓	✓	✓	✓	✓	✓	✓	✓	✓	✓
IEEE 1588 Precision Time Protocol ¹			✓			✓			✓	✓			✓	✓
Storable user sets (config files)	✓	✓	✓	✓	✓	✓	✓	✓	✓	✓	✓	✓	✓	✓
Stream hold	✓	✓	✓	✓	✓	✓	✓	✓	✓	✓	✓	✓	✓	✓
Sync out modes (Trigger ready, input, exposing, readout, imaging, strobe, GPO)	✓	✓	✓	✓	✓	✓	✓	✓	✓	✓	✓	✓	✓	✓
Temperature monitoring (main board only)	✓	✓	✓	✓	✓	✓	✓	✓	✓	✓	✓	✓	✓	✓
Trigger over Ethernet (Action Commands) ¹			✓			✓			✓	✓			✓	✓

¹ Camera must run firmware version 00.01.54.21000 or later.

Table 38: Camera control feature comparison by model



Some features are firmware dependent, refer to the GigE Firmware Release Notes for more information.

Mechanical dimensions

C-Mount (default)

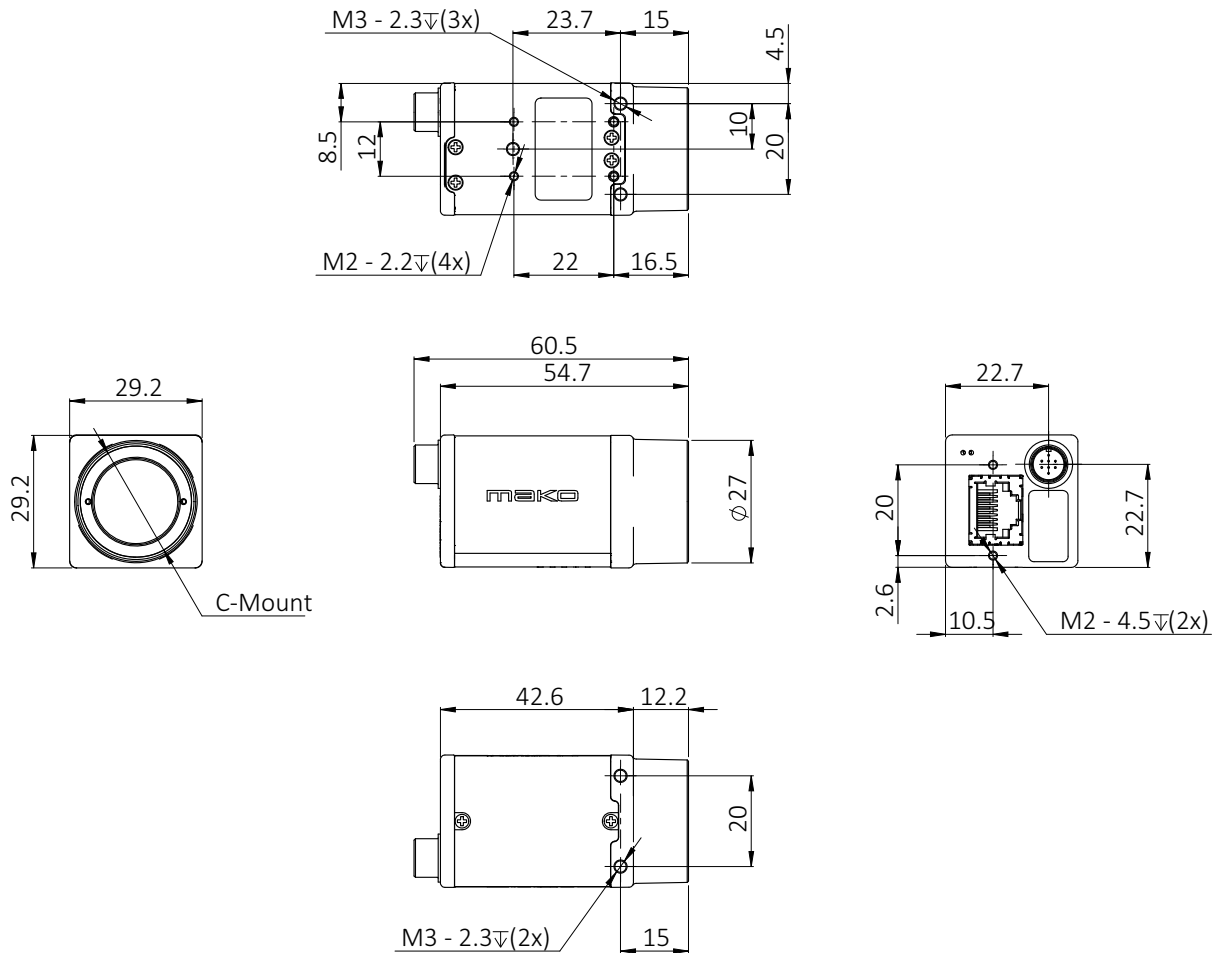

Figure 41: Mako G with C-Mount dimensions (including connectors)

CS-Mount



Contact Allied Vision support for a technical drawing of the Mako G with a CS-Mount. A STEP files is available on the technical documentation webpage.

M12-Mount (S-Mount)



Contact Allied Vision support for a technical drawing or STEP file of the Mako G with a M12-Mount (S-Mount).

Tripod adapter

This tripod adapter (Allied Vision order number 4807) can be used for all Mako G cameras with the standard housing.

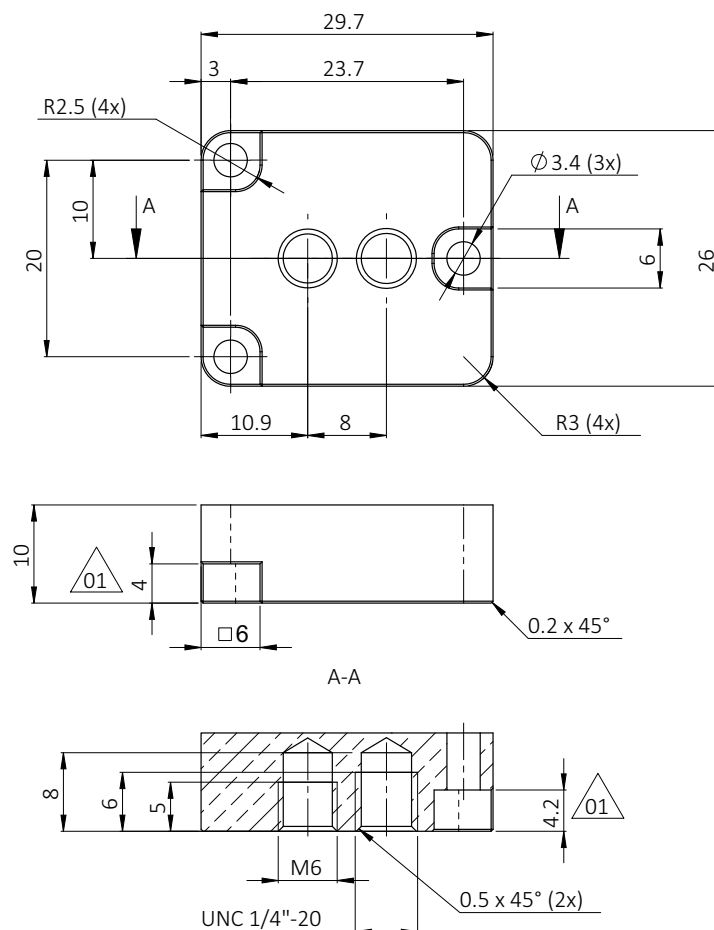

Figure 42: Tripod adapter dimensions (in mm)



NOTICE

Avoid damage to the camera by using inappropriate accessories
The Mako U tripod adapter is not compatible with Mako G cameras.

Sensor position accuracy

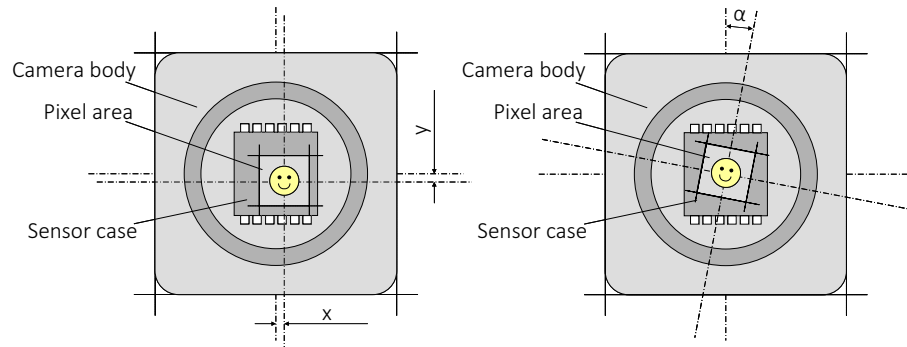

Figure 43: Sensor position accuracy

Unless stated otherwise, the following values are applicable:

Criteria	Subject	Properties
Alignment method		Optical alignment of photo sensitive sensor area into camera front module (lens mount front flange).
Reference points	Sensor	Center of pixel area (photo sensitive cells)
	Camera	Center of camera front flange (outer case edges)
Accuracy	x-axis	$\pm 150 \mu\text{m}$ (sensor shift)
	y-axis	
	z	$0 \mu\text{m}$ to $-150 \mu\text{m}$ (optical back focal length)
	α	$\pm 0.5^\circ$ (sensor rotation as the deviation from the parallel to the camera bottom)

Table 39: Sensor position accuracy criteria

Lens mount cross section

All standard color Mako G cameras are equipped with a Hoya C-5000 IR cut filter with a 22 mm diameter. Standard monochrome and NIR Mako G cameras are not equipped with any optical filter.

We offer several optical filter options for both monochrome, near infrared, and color Mako G cameras. Choose an optical filter according to the Modular Concept.

C-Mount with 22 mm filter (default)

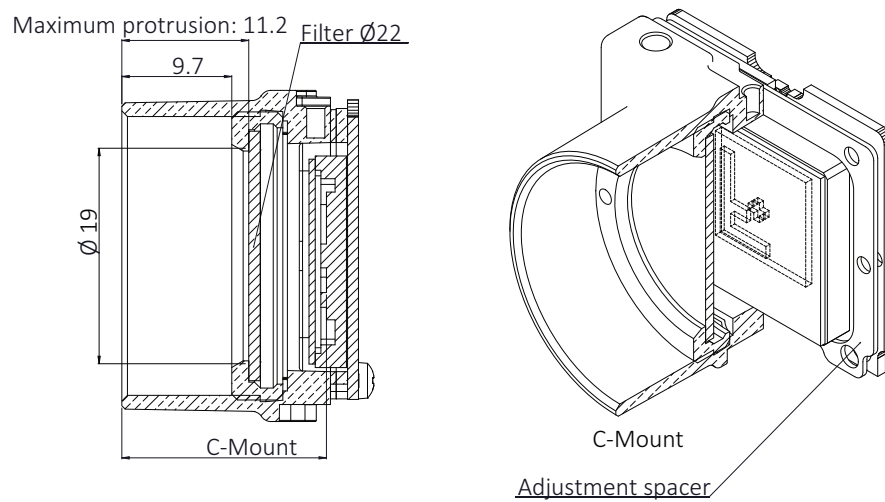

Figure 44: C-Mount with 22 mm filter



Monochrome Mako G cameras with serial number 536873083 or higher are shipped without a cover ring in the C-Mount thread. Refer to product change notice for more details.

CS-Mount with 22 mm filter

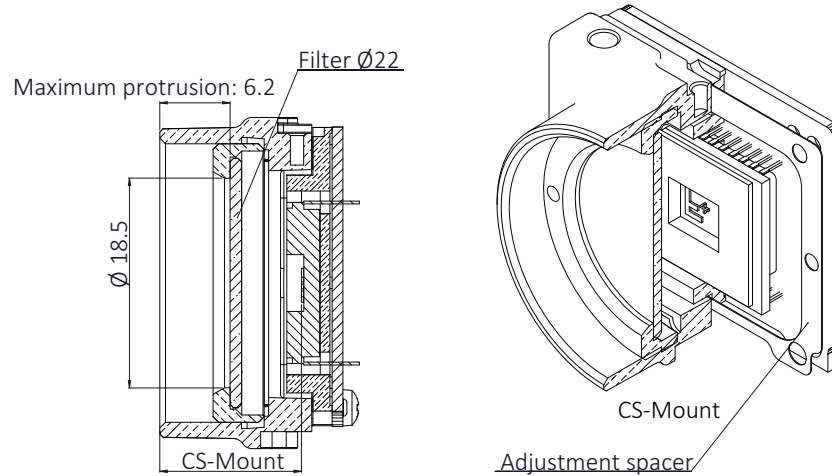

Figure 45: CS-Mount with 22 mm filter

M12-Mount (S-Mount) with 22 mm filter



Contact Allied Vision support for an cross section technical drawing of the Mako G with a M12-Mount (S-Mount) and 22 mm filter.

C-Mount with 16 mm filter

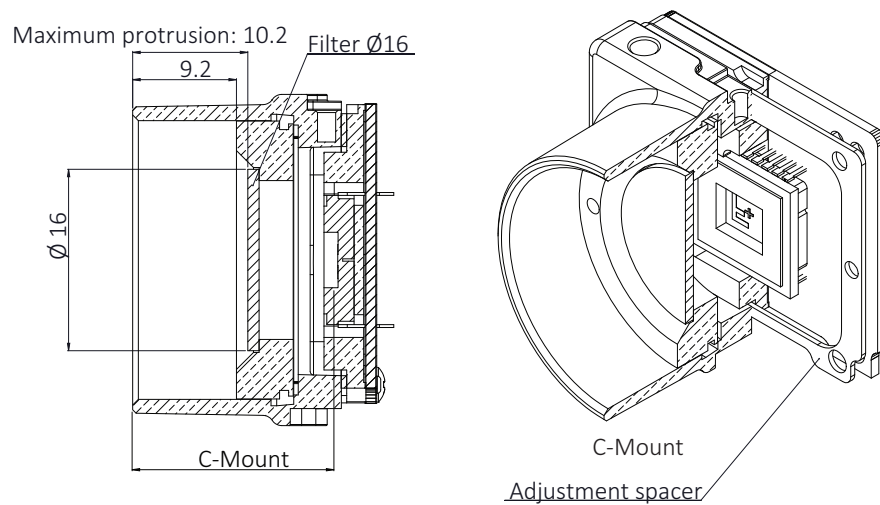

Figure 46: C-Mount with 16 mm filter

CS-Mount with 16 mm filter

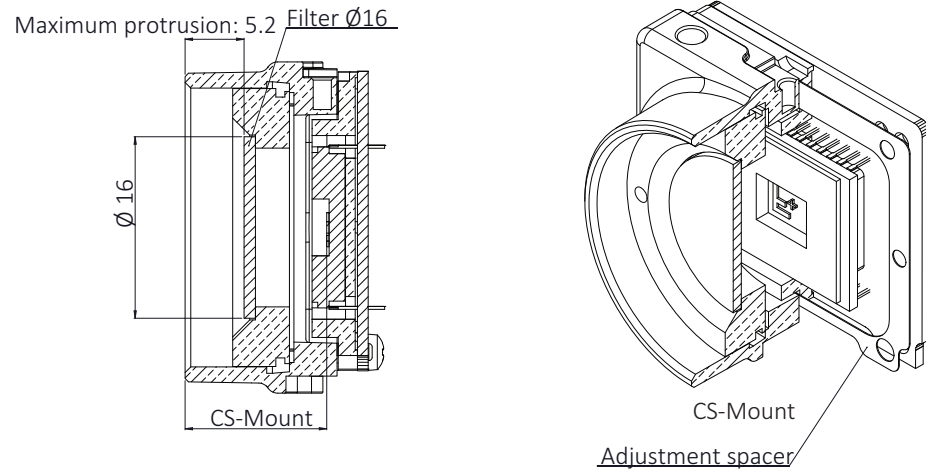

Figure 47: CS-Mount with 16 mm filter

M12-Mount (S-Mount) with 16 mm filter



Contact Allied Vision support for an cross section technical drawing of the Mako G with a M12-Mount (S-Mount) and 16 mm filter.

Dimensional adjustment

The dimensional adjustment cannot be done by the customer. All modifications have to be done by Allied Vision. If you need any mount related adjustments, contact Allied Vision.

Filter and lenses



This chapter includes information on:

- Suitable lens formats for Mako G camera models
- Standard IR cut filter and its transmission characteristics

Camera lenses

We offer different lenses from a variety of manufacturers. This section presents tables that list selected image field of view (width × height) depending on sensor size, distance and focal length of the lens.

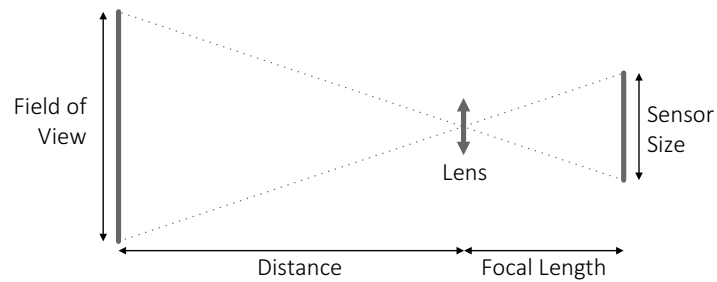

Lenses with focal lengths < 8 mm may show shading in the edges of the image due to microlenses on the sensor. The exact values vary and depend on the respective lens.

Mako G-030 series

The following table provides the field of view for various focal lengths. The values are valid for Mako G-030B and G-030C models.

Focal length	Field of view	
	Distance = 500 mm	Distance = 1000 mm
4.8 mm	495 × 371 mm	995 × 746 mm
8 mm	295 × 221 mm	595 × 446 mm
12.5 mm	187 × 140 mm	379 × 284 mm
16 mm	145 × 109 mm	295 × 221 mm
25 mm	91 × 68 mm	187 × 140 mm
50 mm	43 × 32 mm	91 × 68 mm

Table 40: Mako G-030 series focal length versus field of view

Mako G-032 series

The following table provides the field of view for various focal lengths. The values are valid for Mako G-032B and G-032C models.

Focal length	Field of view	
	Distance = 500 mm	Distance = 1000 mm
4.0 mm	608 × 446 mm	1220 × 896 mm
4.8 mm	506 × 371 mm	1016 × 746 mm
8 mm	301 × 221 mm	608 × 446 mm
12 mm	199 × 146 mm	403 × 296 mm
16 mm	148 × 109 mm	301 × 221 mm
25 mm	93 × 68 mm	191 × 140 mm
35 mm	65 × 48 mm	135 × 99 mm

Table 41: Mako G-032 series focal length versus field of view

Mako G-040 series

The following table provides the field of view for various focal lengths. The values are valid for Mako G-040B and G-040C models.

Focal length	Field of view	
	Distance = 500 mm	Distance = 1000 mm
2.8 mm	888 × 666 mm	1781 × 1336 mm
4 mm	620 × 465 mm	1245 × 934 mm
4.2 mm	590 × 443 mm	1185 × 889 mm
4.8 mm	516 × 387 mm	1037 × 778 mm
6 mm	412 × 309 mm	828 × 621 mm
6.5 mm	380 × 285 mm	764 × 573 mm
8 mm	308 × 231 mm	620 × 465 mm
12 mm	203 × 153 mm	412 × 309 mm
16 mm	151 × 113 mm	308 × 231 mm
25 mm	95 × 71 mm	195 × 146 mm

Table 42: Mako G-040 series focal length versus field of view

Mako G-131 series

The following table provides the field of view for various focal lengths. The values are valid for Mako G-131B and G-131C models.

Focal length	Field of view	
	Distance = 500 mm	Distance = 1000 mm
4.5 mm	760 × 606 mm	1526 × 1217 mm
6 mm	568 × 453 mm	1143 × 911 mm
10 mm	338 × 270 mm	683 × 545 mm
17 mm	196 × 156 mm	399 × 318 mm
25 mm	131 × 105 mm	269 × 215 mm
35 mm	92 × 73 mm	190 × 152 mm

Table 43: Mako G-131 series focal length versus field of view

Mako G-158 series

The following table provides the field of view for various focal lengths. The values are valid for Mako G-158B and G-158C models.

Focal length	Field of view	
	Distance = 500 mm	Distance = 1000 mm
2.8 mm	888 × 666 mm	1781 × 1336 mm
4 mm	620 × 465 mm	1245 × 934 mm
4.2 mm	590 × 443 mm	1185 × 889 mm
4.8 mm	516 × 387 mm	1037 × 778 mm
6 mm	412 × 309 mm	828 × 621 mm
6.5 mm	380 × 285 mm	764 × 573 mm
8 mm	308 × 231 mm	620 × 465 mm
12 mm	203 × 153 mm	412 × 309 mm
16 mm	151 × 113 mm	308 × 231 mm
25 mm	95 × 71 mm	195 × 146 mm

Table 44: Mako G-158 series focal length versus field of view

Mako G-192 series

The following table provides the field of view for various focal lengths. The values are valid for Mako G-192B and G-192C models.

Focal length	Field of view	
	Distance = 500 mm	Distance = 1000 mm
4.5 mm	793 × 595 mm	1593 × 1195 mm
6 mm	593 × 445 mm	1193 × 895 mm
10 mm	353 × 265 mm	713 × 535 mm
17 mm	205 × 153 mm	416 × 312 mm
25 mm	137 × 103 mm	281 × 211 mm
35 mm	96 × 72 mm	199 × 149 mm

Table 45: Mako G-192 series focal length versus field of view

Mako G-223 series

The following table provides the field of view for various focal lengths. The values are valid for Mako G-223B, G-223B NIR, and G-232C models.

Focal length ¹	Field of view	
	Distance = 500 mm	Distance = 1000 mm
4.8 mm	1162 × 617 mm	2335 × 1240 mm
6 mm	927 × 492 mm	1865 × 991 mm
6.5 mm	855 × 454 mm	1721 × 914 mm
8 mm	692 × 368 mm	1396 × 742 mm
10 mm	552 × 293 mm	1114 × 597 mm
12 mm	458 × 243 mm	927 × 492 mm
16 mm	341 × 181 mm	692 × 369 mm
25 mm	214 × 114 mm	439 × 223 mm
35 mm	150 × 79 mm	310 × 165 mm
50 mm	101 × 54 mm	214 × 114 mm
75 mm	64 × 34 mm	139 × 74 mm
90 mm	51 × 27 mm	114 × 60 mm

¹ A 2/3 inch lens may cause vignetting (1 inch lens recommended)

Table 46: Mako G-223 series focal length versus field of view

Mako G-234 series

The following table provides the field of view for various focal lengths. The values are valid for Mako G-234B and G-234C models.

Focal length	Field of view	
	Distance = 500 mm	Distance = 1000 mm
12 mm	461 × 290 mm	933 × 586 mm
16 mm	343 × 215 mm	697 × 438 mm
25 mm	215 × 135 mm	442 × 278 mm
35 mm	150 × 94 mm	312 × 196 mm
50 mm	102 × 64 mm	215 × 135 mm

Table 47: Mako G-234 series focal length versus field of view

Mako G-319 series

The following table provides the field of view for various focal lengths. The values are valid for Mako G-319B and G-319C models.

Focal length	Field of view	
	Distance = 500 mm	Distance = 1000 mm
5 mm	705 × 525 mm	1417 × 1055 mm
6 mm	586 × 436 mm	1180 × 878 mm
8 mm	438 × 326 mm	883 × 657 mm
10 mm	349 × 260 mm	705 × 525 mm
12 mm	290 × 216 mm	586 × 436 mm
16 mm	215 × 160 mm	438 × 326 mm
25 mm	135 × 101 mm	278 × 207 mm
35 mm	95 × 70 mm	196 × 146 mm
50 mm	64 × 48 mm	135 × 101 mm
75 mm	40 × 30 mm	88 × 65 mm

Table 48: Mako G-319 series focal length versus field of view

Mako G-419 series

The following table provides the field of view for various focal lengths. The values are valid for Mako G-419B, G-419B NIR, and G-419C models.

Focal length	Field of view	
	Distance = 500 mm	Distance = 1000 mm
8 mm	692 × 692 mm	1396 × 1396 mm
10 mm	552 × 552 mm	1114 × 1114 mm
12 mm	458 × 458 mm	928 × 928 mm
16 mm	340 × 340 mm	692 × 692 mm
25 mm	214 × 214 mm	439 × 439 mm
35 mm	150 × 150 mm	310 × 310 mm
50 mm	101 × 101 mm	214 × 214 mm
75 mm	64 × 64 mm	139 × 139 mm
90 mm	51 × 51 mm	104 × 104 mm

Table 49: Mako G-419 series focal length versus field of view

Mako G-503 series

The following table provides the field of view for various focal lengths. The values are valid for Mako G-503B and G-503C models.

Focal length	Field of view	
	Distance = 500 mm	Distance = 1000 mm
4.8 mm	588 × 442 mm	1182 × 887 mm
8 mm	351 × 263 mm	707 × 531 mm
12 mm	232 × 174 mm	469 × 352 mm
16 mm	172 × 129 mm	351 × 263 mm
25 mm	108 × 81 mm	222 × 167 mm
35 mm	76 × 57 mm	157 × 118 mm

Figure 48: Mako G-503 series focal length versus field of view

Mako G-507 series

The following table provides the field of view for various focal lengths. The values are valid for Mako G-507B and G-507C models.

Focal length	Field of view	
	Distance = 500 mm	Distance = 1000 mm
5 mm	842 × 703 mm	1692 × 1413 mm
8 mm	526 × 437 mm	1054 × 880 mm
10 mm	417 × 348 mm	842 × 703 mm
12 mm	346 × 289 mm	700 × 585 mm
16 mm	257 × 215 mm	523 × 437 mm
25 mm	162 × 135 mm	332 × 277 mm
35 mm	113 × 94 mm	234 × 196 mm
50 mm	77 × 64 mm	162 × 135 mm
75 mm	48 × 40 mm	105 × 88 mm

Figure 49: Mako G-507 series focal length versus field of view

Mako G-508B POL

The following table provides the field of view for various focal lengths. The values are valid for Mako G-508B POL models.

Focal length	Field of view	
	Distance = 500 mm	Distance = 1000 mm
5 mm	842 × 703 mm	1692 × 1413 mm
8 mm	526 × 437 mm	1054 × 880 mm
10 mm	417 × 348 mm	842 × 703 mm
12 mm	346 × 289 mm	700 × 585 mm
16 mm	257 × 215 mm	523 × 437 mm
25 mm	162 × 135 mm	332 × 277 mm
35 mm	113 × 94 mm	234 × 196 mm
50 mm	77 × 64 mm	162 × 135 mm
75 mm	48 × 40 mm	105 × 88 mm

Figure 50: Mako G-508B POL focal length versus field of view

IR cut filter

Color cameras are equipped with IR cut filter. The following plot shows the spectral transmission of the IR cut filter.

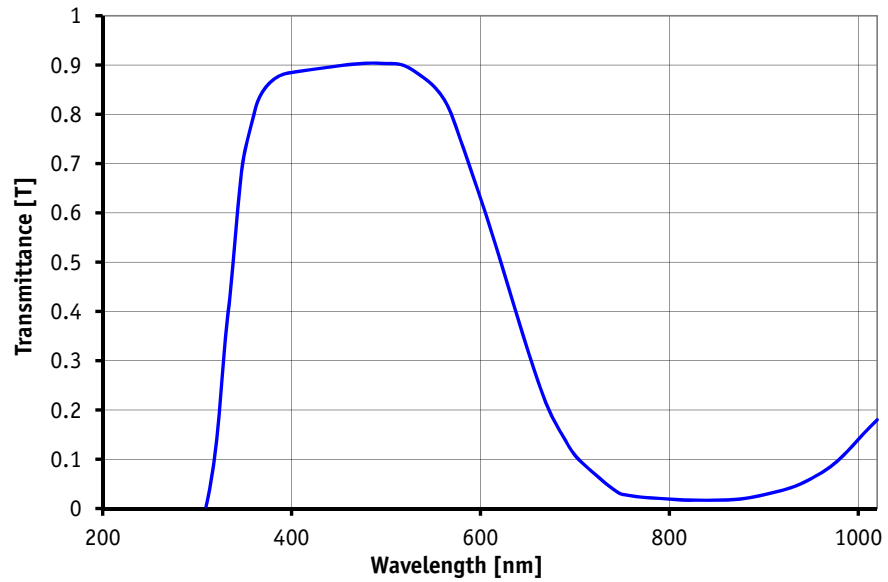
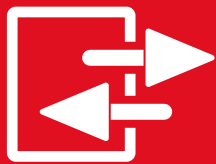

Figure 51: Approximate spectral transmission of IR cut filter type Hoya C-5000 (may vary slightly by filter lot)

Camera interfaces



This chapter includes:

- A general description of the inputs and outputs (including trigger features)
- I/O connector pin assignments
- I/O block diagrams
- A general description of trigger rules including a timing diagram and definitions

Back panel

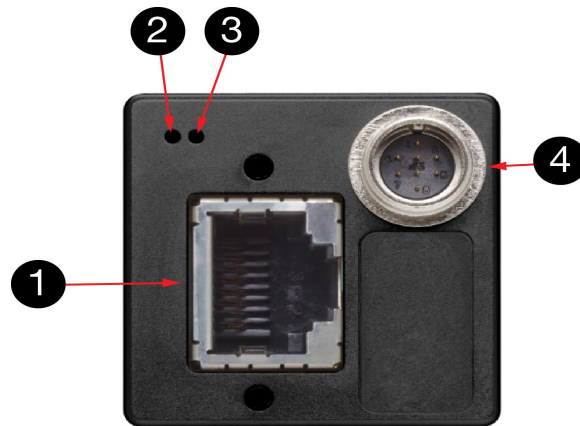

Figure 52: Rear view of Mako G cameras

1	Gigabit Ethernet port
2	LED 1 (orange)
3	LED 2 (green)
4	Hirose I/O port

Table 50: Ports and LEDs

Status LEDs

The following tables describe the Mako G status LEDs.

LED 1 color	Status
Solid orange	Ethernet link established
Flashing orange	Network traffic

Table 51: Status LED 1

LED 2 color	Status
Solid green	Camera powered

Table 52: Status LED 2 (sheet 1 of 2)

LED 2 color	Status
Slow flashing green	Booting routine
Four rapid flashes per second	Transmission error Contact support@alliedvision.com

Table 52: Status LED 2 (sheet 2 of 2)

Gigabit Ethernet port

The Gigabit Ethernet port conforms to the IEEE 802.3 1000BASE-T standard for Gigabit Ethernet over copper. To prevent electromagnetic interference (EMI) and for best performance, Category 6 (or higher) cables with S/STP shielding and connectors are recommended. Applications with longer cable lengths or harsh EMI conditions require Category 7 (or higher) cables.



- Cable lengths up to 100 meters are supported.
- The 8-pin RJ-45 jack provides a pin assignment according to the Ethernet standard, IEEE 802.3 1000BASE-T.
- All Mako G cameras are PoE capable (IEEE 802.3at Type 1).
- If both the Hirose I/O port and Gigabit Ethernet port (via PoE) are used for power, the camera only uses the power from the Hirose I/O port.

Camera I/O connections

The general purpose I/O port uses a Hirose HR25-7TR-8PA(73) connector on the camera side. The mating cable connector is Hirose HR25-7TP-8S.



NOTICE

The camera is not intended to be connected to a DC distribution network. The maximum length for I/O cables must not exceed 30 meters.



Safety-related instructions to avoid malfunctions

Read all Notes and Cautions in the Hardware and Installation chapter before using the Hirose I/O connector.



Hirose connector

The cable side Hirose connector is available for purchase from Allied Vision (order code K7600503).

I/O connector pin assignment

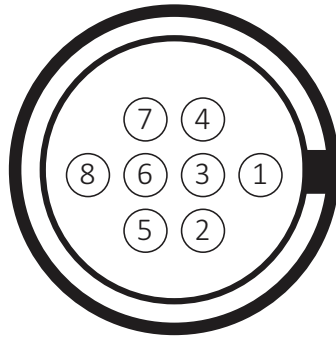

Camera side Hirose HR25-7TR-8PA(73) connector					I/O cable color code
Pin	Signal	Direction	Level	Description	
1	Out 1	Out	Open emitter, maximum 20 mA	Opto-isolated output 1	Yellow dot Red
2	Out 2	Out	Open emitter, maximum 20 mA	Opto-isolated output 2	Yellow dot Black
3	Out 3	Out	Open emitter, maximum 20 mA	Opto-isolated output 3	Gray dot Red
4	In 1	In	$U_{in}(\text{high}) = 3.0 \text{ to } 24.0 \text{ V}$ up to 36 V with external resistor of 3.3 k Ω in series $U_{in}(\text{low}) = 0 \text{ to } 1.0 \text{ V}$	Opto-isolated input 1	Gray dot Black
5	Isolated In GND	In	---	Isolated input signal ground	Pink dot Black
6	Isolated Out Power	In	Common VCC for outputs maximum 30 VDC	Power input for opto-isolated outputs	Pink dot Red
7	Camera Power	In	12 to 24 VDC $\pm 10\%$	Camera power supply	Orange dot Black
8	Camera GND	In	Ground for external power	Ground for camera power supply	Orange dot Red

Table 53: Camera I/O connector pin assignment and I/O cable color coding



For cable color and pin out information, see the Allied Vision I/O cable data sheet:

www.alliedvision.com/en/support/technical-documentation/accessories-data-sheets.html

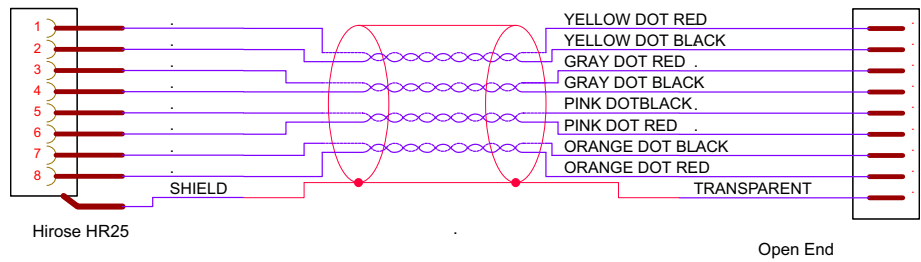

Figure 53: Mako G cable color coding

Input block diagram

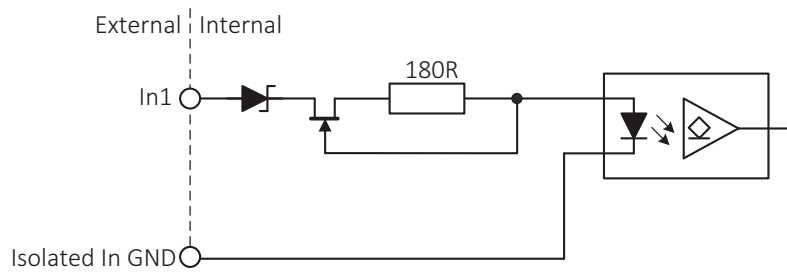

Figure 54: Input block diagram

The input can be connected directly to the system for voltages up to 24 VDC. An external resistor is not necessary.

Cycle delay

Parameter	Value
U_{in} (low)	0 to 1.0 V
U_{in} (high)	3 to 24 V
Current (constant-current source)	3 to 4 mA

Table 54: Input parameters

Minimum pulse width

The minimum pulse width for all Mako G cameras is:

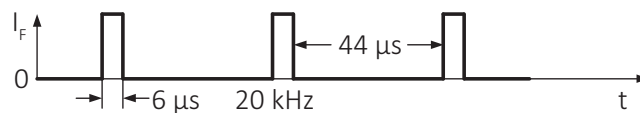

Figure 55: Minimum pulse width

Test conditions

The input signal was driven with 3.3 Volts and no external additional series resistor.

Output block diagram

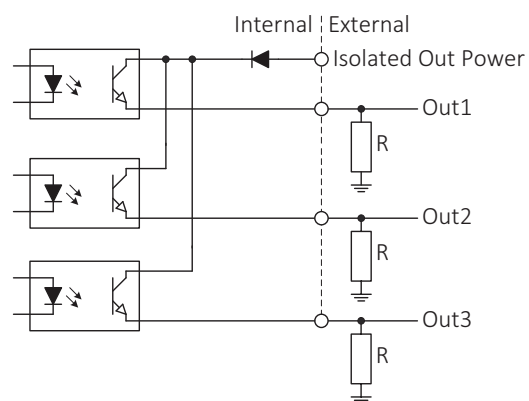

Figure 56: Output block diagram

NOTICE

Output and isolated out power:

- Maximum 20 mA per output
- Isolated out power > 30 V may damage the camera

Isolated Out Power	Resistor value ¹	
5 V	1.0 kΩ	at ~ 5 mA minimum required current draw
12 V	2.4 kΩ	
24 V	4.7 kΩ	

¹ Resistor required if Out1, Out2, Out3 connected to a device with < 5 mA draw, that is, high impedance

Table 55: Isolated Out Power and external resistor

Output switching times

Optocoupler input (internal)

Optocoupler output (external)

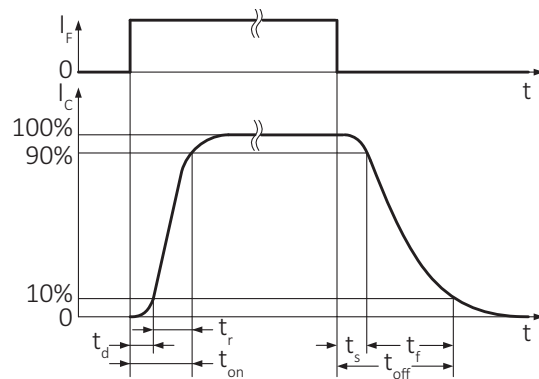

t_d delay time t_s storage time
 t_r rise time t_f fall time
 $t_{on} (= t_d + t_r)$ turn-on time $t_{off} (= t_s + t_f)$ turn-off time

Figure 57: Output switching times

Parameter and value	
$t_d \approx 1 \mu\text{s}$	$t_s \approx 26 \mu\text{s}$
$t_r \approx 1 \mu\text{s}$	$t_f \approx 21 \mu\text{s}$
$t_{on} = t_d + t_r \approx 2 \mu\text{s}$	$t_{off} = t_s + t_f \approx 47 \mu\text{s}$ (t_{off} can deviate by $\pm 5 \mu\text{s}$)

Table 56: Parameters

Test conditions

Output: external 2.4 k Ω resistor to ground, Isolated Out Power set to 12 Volts.



- Higher external values increase the times.
- It is recommended to trigger on the rising edge. This guarantees the fastest possible reaction time.

Control signals

The inputs and outputs of the camera can be configured by software. The different modes are described in this section. All input and output signals that pass the I/O connector are controlled by the I/O strobe commands.

Input block diagram

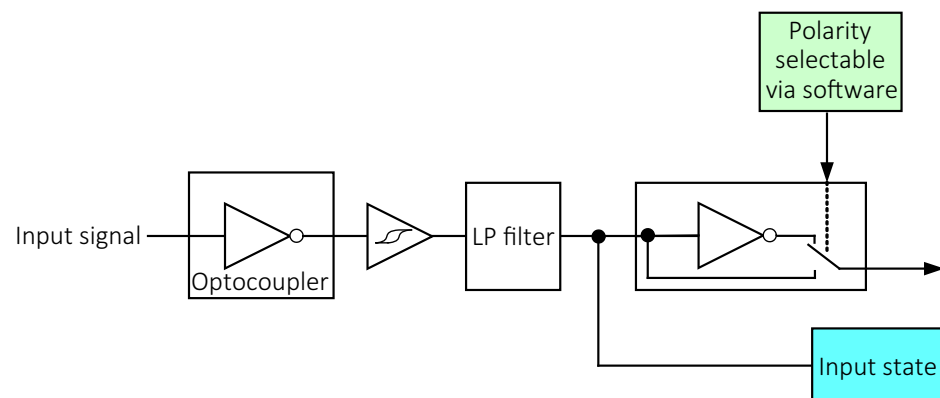

Figure 58: Input block diagram

Output signals

Output signals are configured by software. Any signal can be placed on any output. The main output signals are described in the following table.

Signal	Description
GPO	Configured to be a general purpose output, control is assigned to <code>SyncOutGpoLevel1s</code> .
AcquisitionTriggerReady	Active after the camera has been recognized by the host computer and is ready to start acquisition.

Table 57: Output signals (sheet 1 of 2)

Signal	Description
FrameTriggerReady	Active when the camera is in a state that accepts the next frame trigger.
FrameTrigger	Active when an image has been initiated to start. This is a logic trigger internal to the camera, which is initiated by an external trigger or software trigger event.
Exposing	Active for the duration of sensor exposure.
FrameReadout	Active during frame readout, that is, the transferring of image data from the sensor to the camera memory.
Imaging	Imaging is high when the camera image sensor is either exposing and/or reading out data.
Acquiring	Active during an acquisition stream.
SyncIn1	Active when there is an external trigger at <i>SyncIn1</i> .
Strobe1	The output signal is controlled according to <i>Strobe1</i> settings.

Table 57: Output signals (sheet 2 of 2)

Output block diagram

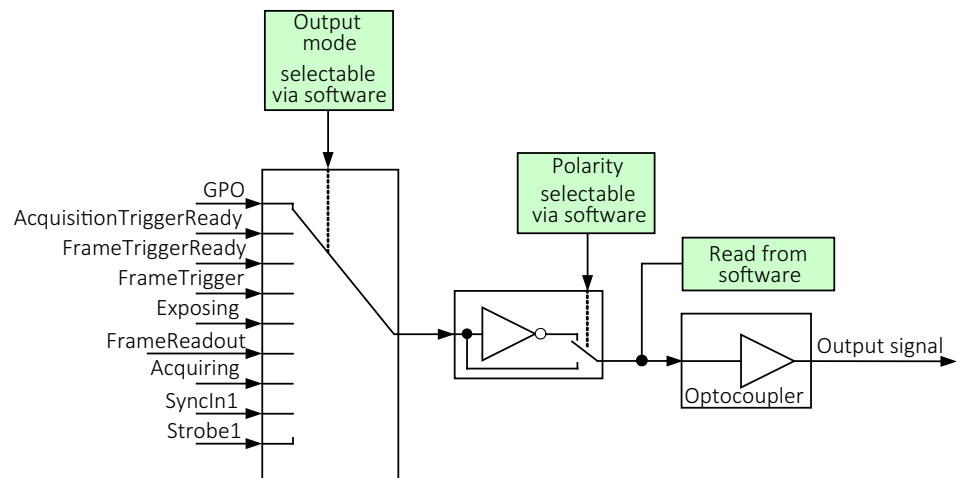

Figure 59: Output block diagram

Camera trigger

For trigger description on camera control basis, see the GigE Features Reference.

Trigger timing diagram

The following diagram explains the general trigger concept for CCD-sensor models.

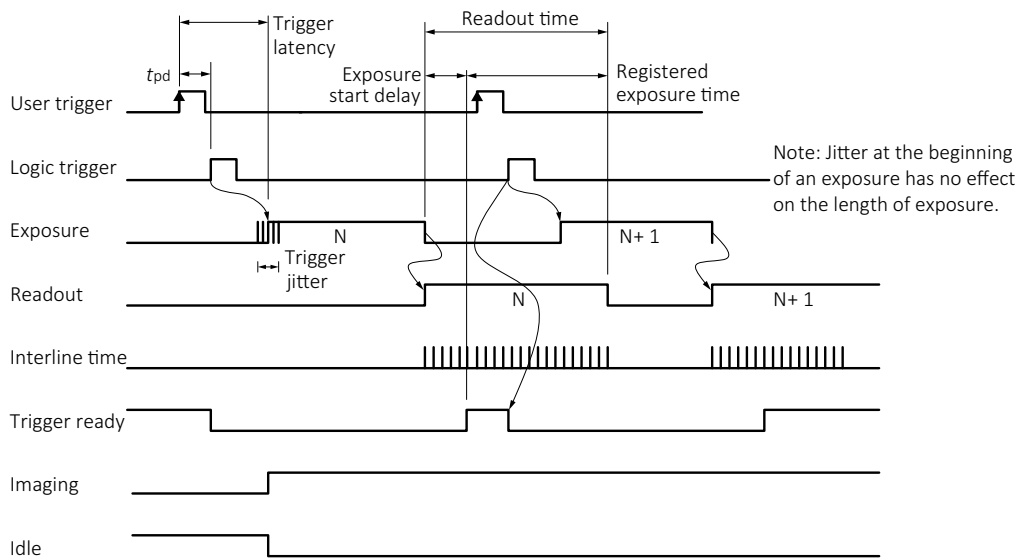

Figure 60: Internal signal timing waveforms (CCD-sensor models)

The following diagram explains the general trigger concept for CMOS-sensor models.

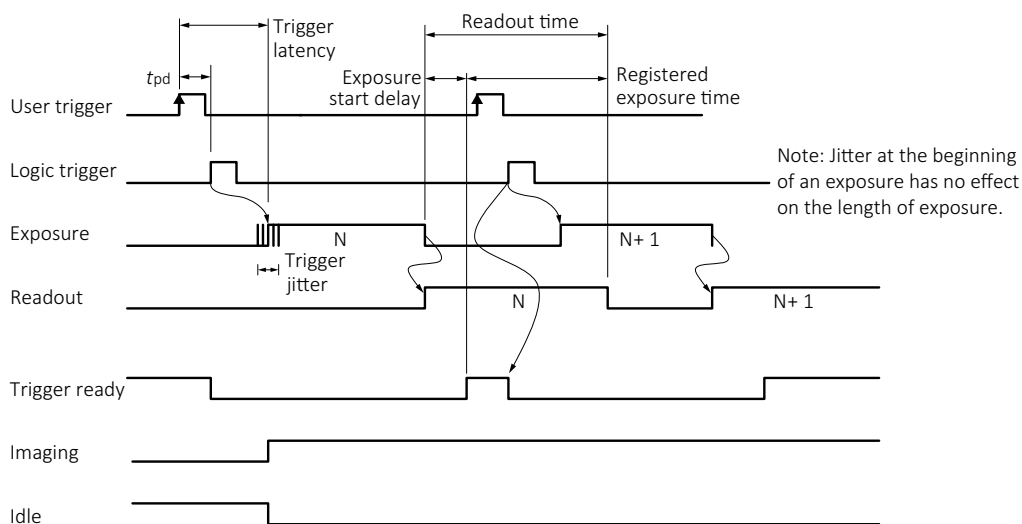

Figure 61: Internal signal timing waveforms (CMOS-sensor models)

Trigger definitions

Term	Definition
User trigger	Trigger signal applied by the user (hardware trigger, software trigger)
Logic trigger	Trigger signal seen by the camera internal logic (not visible to the user)
Propagation delay (t_{pd})	Propagation delay between the user trigger and the logic trigger
Exposure	High when the camera image sensor is integrating light
Readout	High when the camera image sensor is reading out data
Trigger latency	Time delay between user trigger and start of exposure
Trigger jitter	Error in the trigger latency time
Trigger ready	Indicates that the camera can accept the next trigger
Registered exposure time	Exposure time value currently stored in the camera memory
Exposure start delay	Registered exposure time subtracted from the readout time and indicates when the next exposure cycle can begin such that the exposure ends after the current readout
Interline time	Time between sensor row readout cycles (CCD models only)
Imaging	High when the camera image sensor is either exposing and/or reading out data
Idle	High if the camera image sensor is not exposing and/or reading out data

Table 58: Trigger definitions

Trigger rules



Overlapping exposure and readout (Mako G-131 and G-192)

The Teledyne e2v sensor does not support overlapped exposure and readout in hardware trigger mode or in global reset mode.

- The user trigger pulse width should be at least 6 μ s.
- The end of exposure always triggers the next readout.
- The end of exposure must always end after the current readout.
- The start of exposure must always correspond with the interline time if readout is true.
- Exposure start delay equals the readout time minus the registered exposure time.

Triggering during the idle state

For applications requiring the shortest possible trigger latency and the smallest possible trigger jitter, the user trigger signal should be applied when imaging is false and idle is true.

Triggering during the readout state

For applications requiring the fastest triggering cycle time whereby the camera image sensor is exposing and reading out simultaneously, the user trigger signal should be applied as soon as a valid trigger ready is detected.

In this case, trigger latency and trigger jitter can be up to one line time since exposure must always begin on an Interline boundary.



For a more detailed description of the trigger concept for advanced users and special scenarios, see the Triggering Concept application note:

www.alliedvision.com/en/support/technical-papers-knowledge-base.html

Image data flow

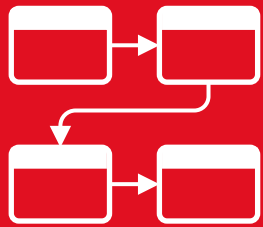

This chapter presents diagrams that illustrate data flow and bit resolution of the image data.

A complete listing of camera features, including definitions can be found on the Allied Vision Technical Documentation webpage.

- Vimba and third-party users: GigE Features Reference
- PvAPI users: GigE Camera and Driver Attributes document

Mako G model series with CCD sensors

Mako G-032 and G-125 series

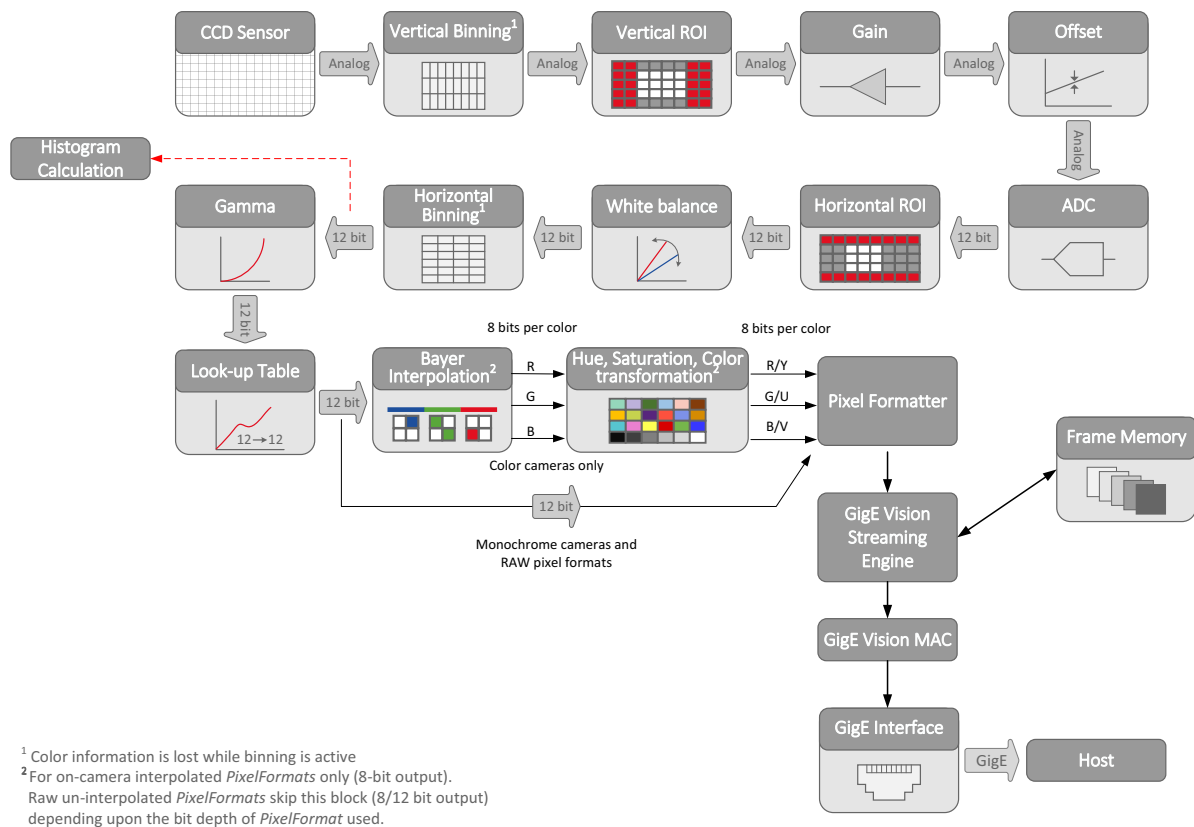

Figure 62: Mako G-032 and G-125 series image data flow

Mako G model series with CMOS sensors

Mako G-030 series

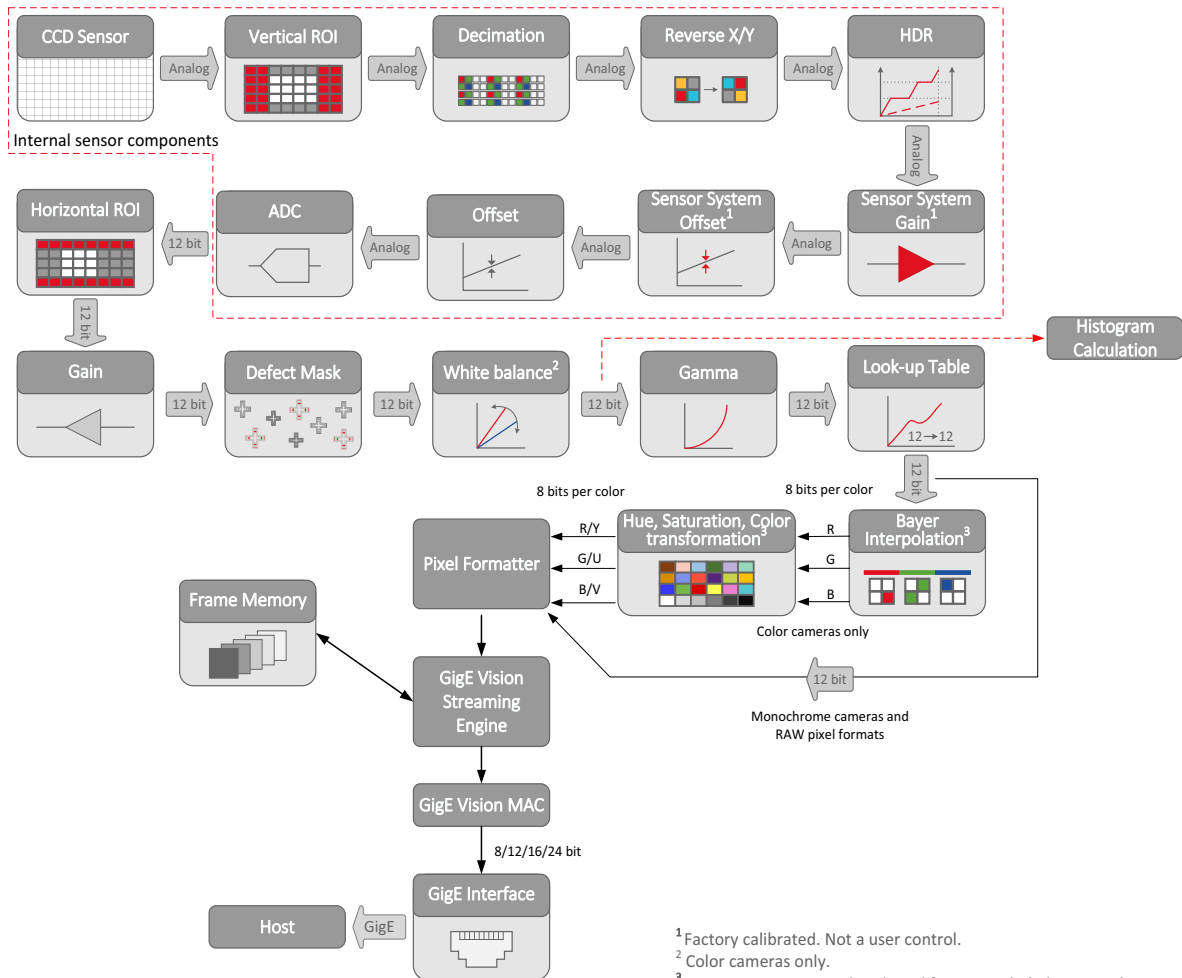

Figure 63: Mako G-030 series image data flow

Mako G-131 and G-192 series

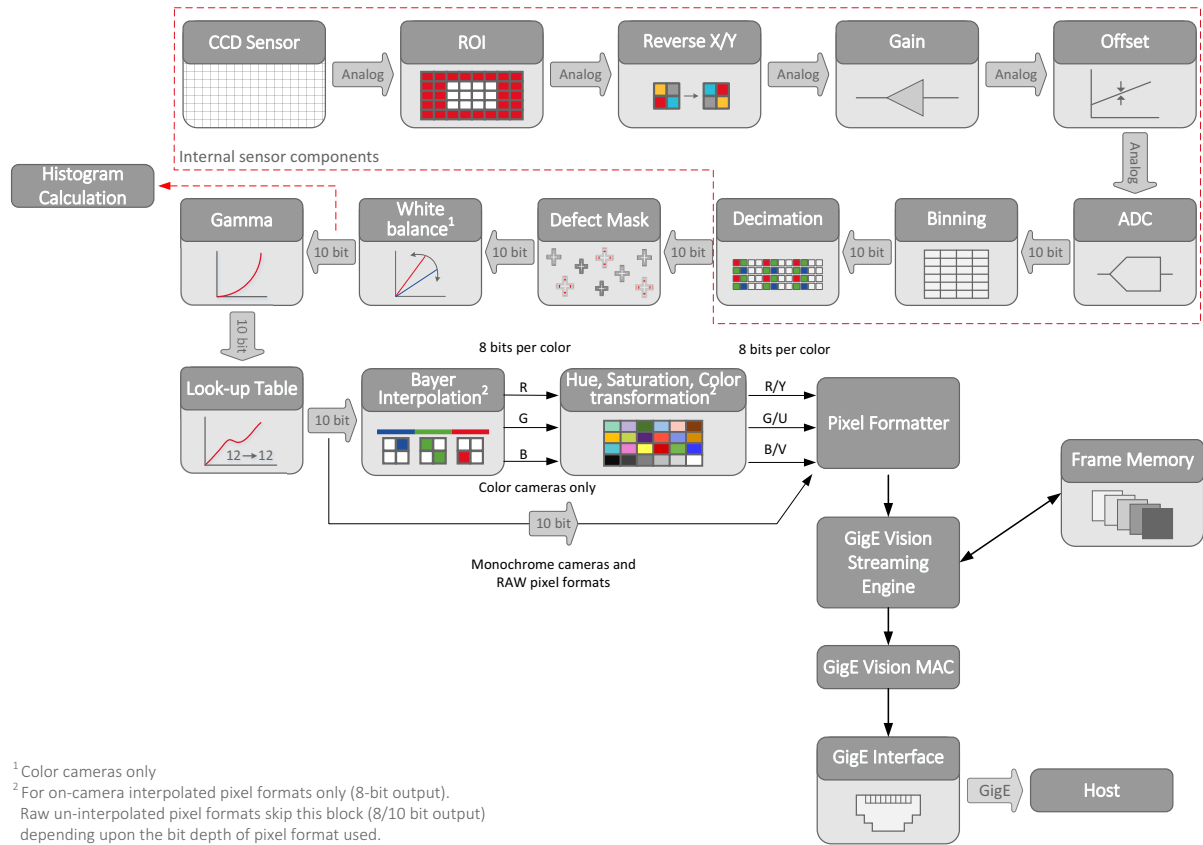

Figure 64: Mako G-131 and G-192 series image data flow

Mako G-223 and G-419 series

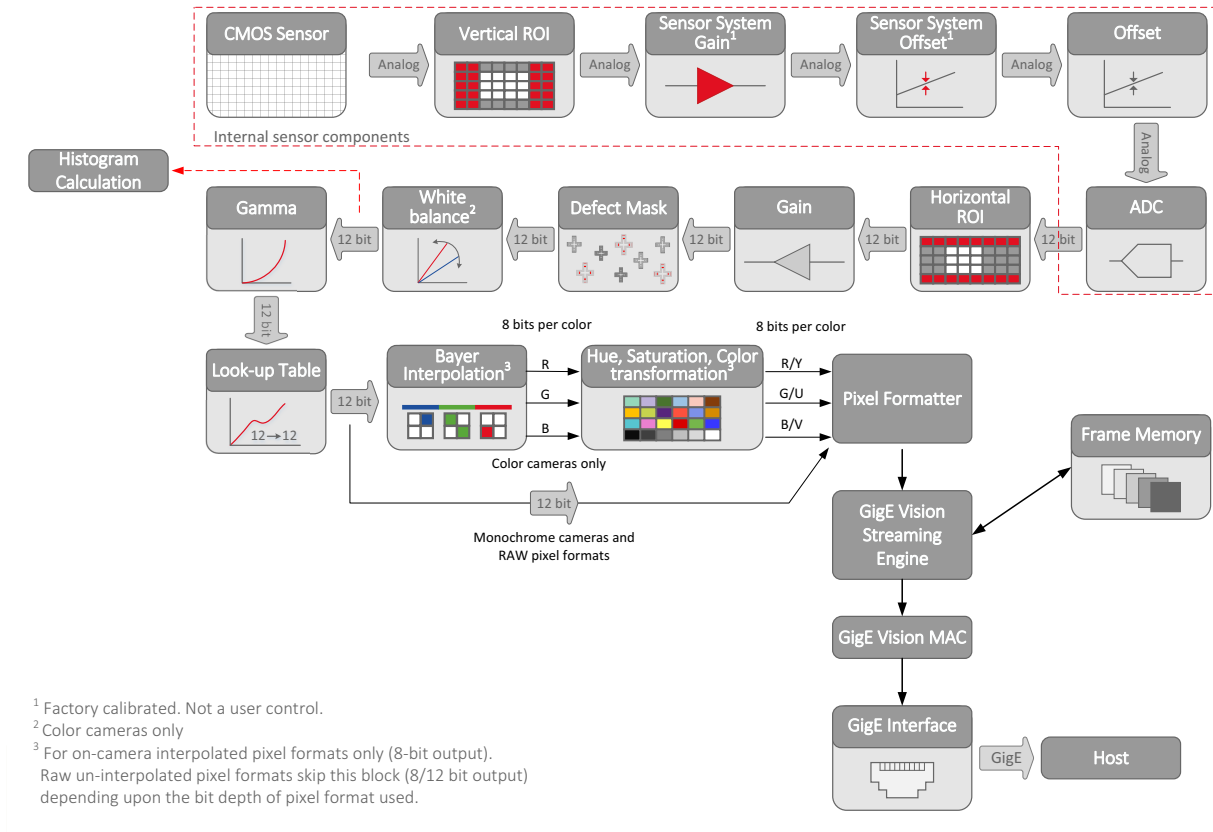

Figure 65: Mako G-223 and G-419 series image data flow

Mako G-040, G-158, G-234, G-319, G-507 series and G-508B POL

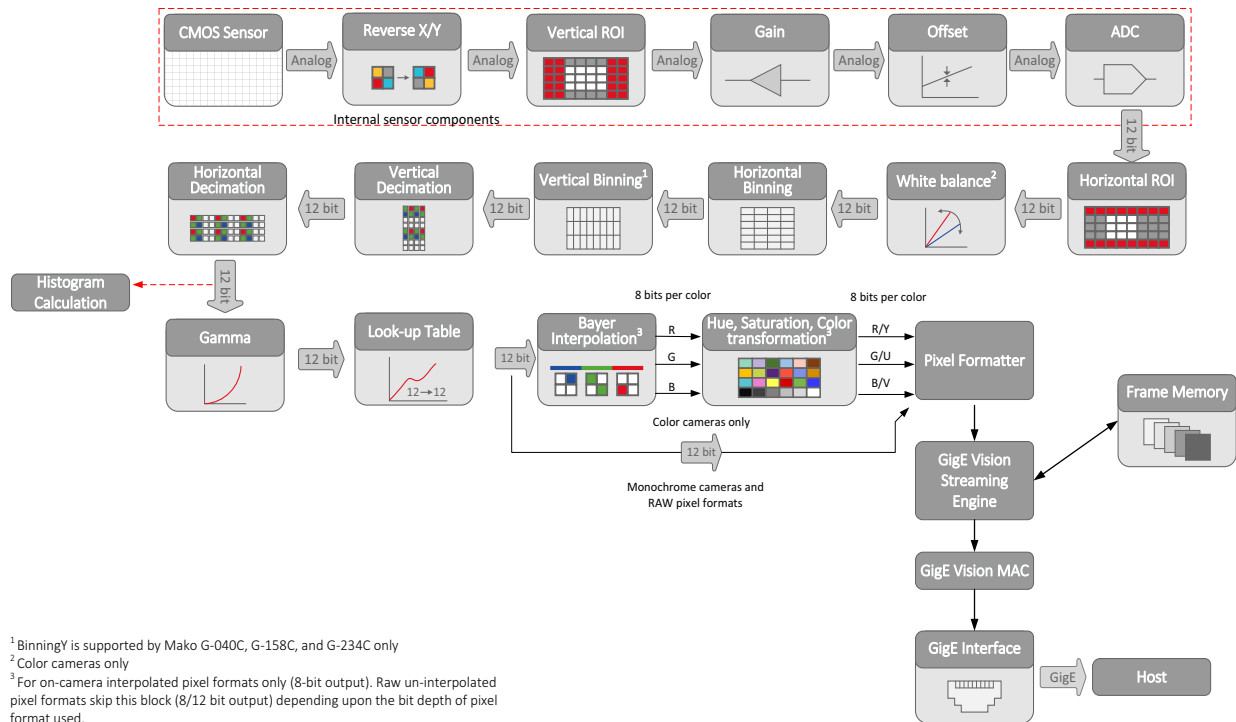

Figure 66: Mako G-040, G-158, G-234, G-319, G-507 series and G-508B POL image data flow



Mako G-234B, G-234C supports 10-bit and 12-bit sensor readout mode. 10-bit data is processed as 12-bit data with 2 LSB bits padded with zeros.

Mako G-503 series

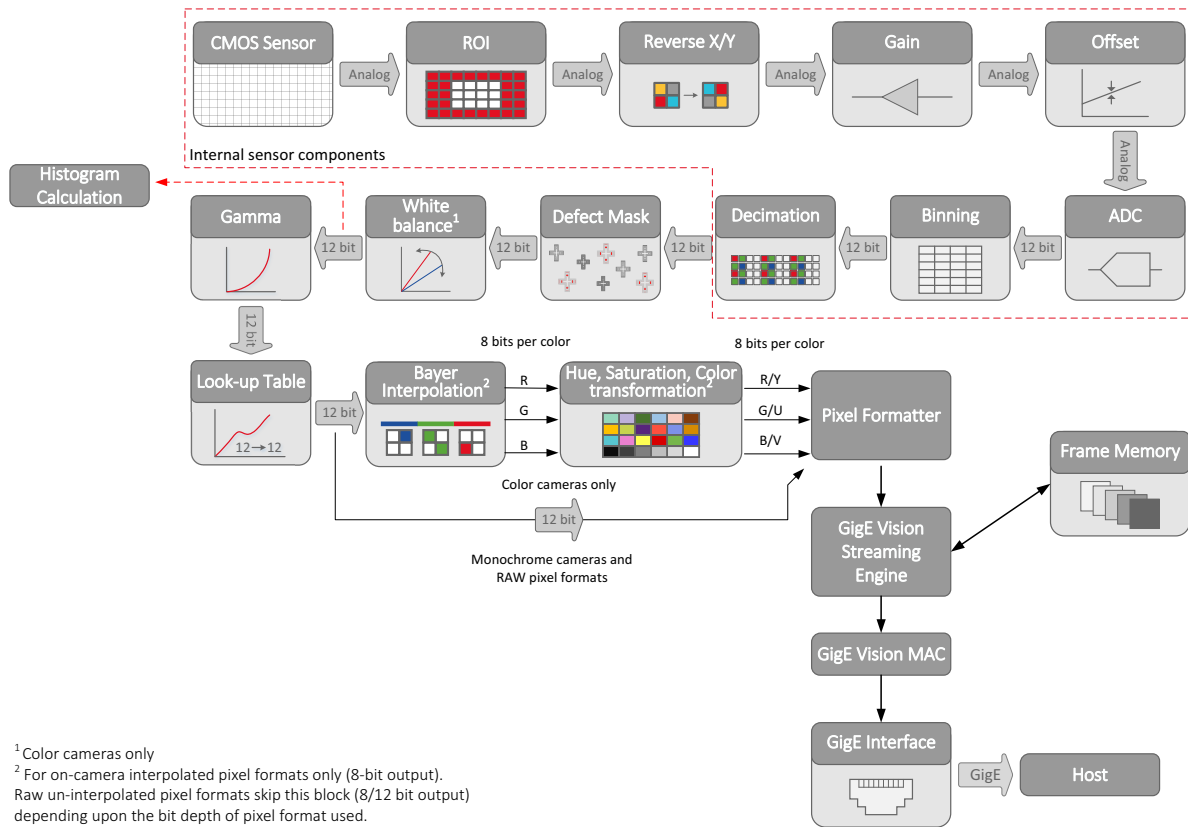

Figure 67: Mako G-503 series image data flow

Color interpolation (Bayer demosaicing)

The color sensors capture the color information via so-called primary color (R-G-B) filters placed over the individual pixels in a Bayer mosaic layout. An effective Bayer to RGB color interpolation already takes place in all Mako G color version cameras.

In color interpolation a red, green, or blue value is determined for each pixel. A proprietary Bayer demosaicing algorithm is used for this interpolation, optimized for both sharpness of contours as well as reduction of false edge coloring.

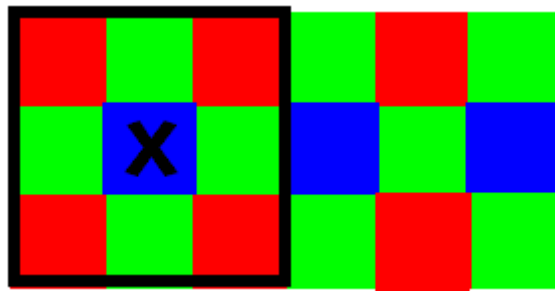

Figure 68: Bayer demosaicing (example of 3×3 matrix)

Color processing can be bypassed by using the RAW image transfer.

RAW mode is primarily used to:

- save bandwidths on the Gigabit Ethernet network
- achieve higher frame rates
- use different Bayer demosaicing algorithms on the host computer
 - for Mako G, the first pixel of the sensor is red



When the host computer does not perform Bayer to RGB post-processing, the monochrome image is superimposed with a checkerboard pattern.

In color interpolation a red, green, or blue value is determined for each pixel (P1= first pixel; P2= second pixel). Only two lines are needed for this interpolation:

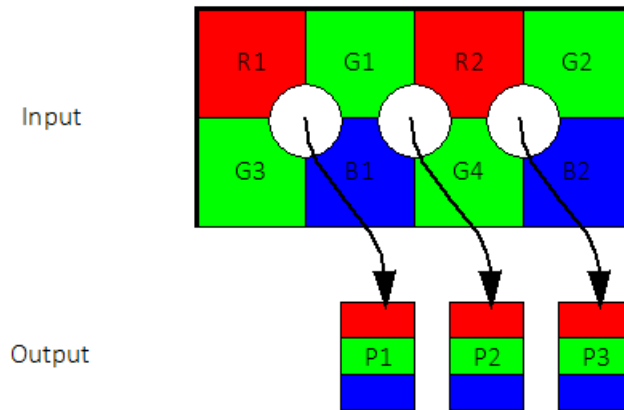

Figure 69: Bayer demosaicing (interpolation)

$$\begin{array}{lll}
 P1_{\text{red}} = R1 & P2_{\text{red}} = R2 & P3_{\text{red}} = R2 \\
 P1_{\text{green}} = \frac{G1 + G3}{2} & P2_{\text{green}} = \frac{G1 + G4}{2} & P3_{\text{green}} = \frac{G2 + G4}{2} \\
 P1_{\text{blue}} = B1 & P2_{\text{blue}} = B1 & P3_{\text{blue}} = B2
 \end{array}$$

Figure 70: Bayer demosaicing



- Note that on the color camera, an incorrectly colored border of one or two pixel wide forms on the left and right image borders. This is also a consequence of Bayer demosaicing as the image width displayed on the color camera is not scaled down.
- Using a ROI, **x** and **y** resolutions must be even-numbered.

Cleaning optical components

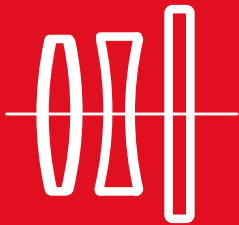

This chapter describes safety instructions and cautions for cleaning lenses, optical filters, and sensors.



Read these instructions before you contact Allied Vision or your Allied Vision distribution partner for assistance.

Contact Allied Vision or your Allied Vision distribution partner if you are not familiar with the procedures described in this chapter.



NOTICE

As monochrome and NIR models do not have an optical filter, always attach a dust cap when a lens is not attached to minimize the possibility of contaminants falling on the sensor surface.

Keeping optical components clean

The best way to ensure the camera remains clean is to avoid penetration of foreign substances into the camera.

When screwing or unscrewing the camera lens or dust cap, hold the camera with the lens mount opening towards the floor. This minimizes the possibility of any contaminants falling on the glass surface. Always store cameras and lenses with dust-caps on.



Figure 71: Illustration of camera orientation when removing lens or dust cap

Identifying impurities

If you observe any image artifacts in your video preview of your Mako G camera you may have impurities either on the lens, optical filter, or on the sensor surface. Every Mako G camera is cleaned prior to sealing and shipment; however, impurities may develop due to handling or unclean environments.

As shown in the following figure, impurities (dust, particles, or fluids) on the sensor or optical components appear as a dark area, patch or spot on the image and remain fixed in the preview window while you rotate the camera over the target.

Do not confuse this with a pixel defect which appears as a distinct point. Particles can either rest loosely or can be more or less stuck to the optical surface.

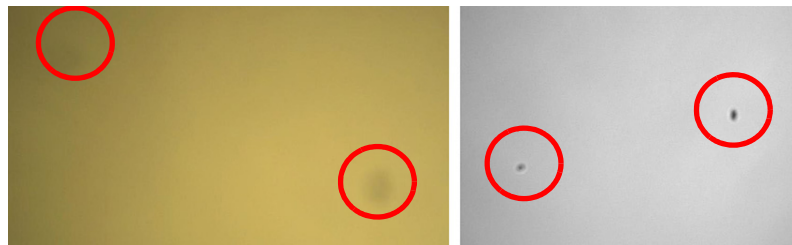

Figure 72: Image with tiny dust on the filter (left) and dust on the sensor (right)

Locating impurities

Before you dismount the lens you should find out if the impurity is on the optical filter, lens, or sensor.

1. Start acquiring a uniform image (for example a white sheet of paper) with the camera.
2. To identify the affected surface, move the suspected optical component and see if the contamination follows this movement.
 - a. If you move only the lens (not the camera) and the impurity moves as well, the impurity is on the lens.

- b. If you move the optical filter window and the impurity moves as well, the impurity is on the optical filter. Carefully remove the optical filter and clean it on both sides using the techniques explained in the next section.



3. If the impurity is neither on the lens nor the optical filter, it is probably on the sensor.

NOTICE

Removing optical filter

To remove the optical filter use the special tool (Allied Vision order code 3851; 22 mm filter).

Removing the IR cut filter

Standard Mako G-507C models with SN \geq 536883430 and all other standard Mako G models with SN \geq 536884750 are equipped with a 22 mm diameter IR cut filter. Filters can be removed with the E9020001 filter removal tool.

For other Mako G cameras, see the following table.

Model	Serial number	Filter glass diameter	Removal tool	Pin distance
Mako G-507C	\geq 536883430	22 mm	E9020001	21 mm
	$<$ 536883430	16 mm	E9020001	21 mm
	$<$ 536883430	22 mm	3581	22 mm
Other models	\geq 536884750	22 mm	E9020001	21 mm
	$<$ 536884750	16 mm	E9020001	21 mm
	$<$ 536884750	22 mm	3581	22 mm

Table 59: Filter removal tools for Mako G cameras

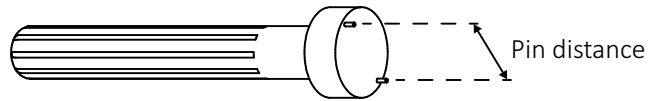

Figure 73: Pin distance for E9020001 filter removal tool

Materials for cleaning optical components



Use only these cleaning materials for optical components

- Optic approved lens cotton, cloth, or tissue that is chemically pure and free from silicones and other additives.
- Optic approved low residue cleaning liquid.



NOTICE

Never use these cleaning materials for optical components:

- Dry swabs or tissue may cause scratches.
- Metal tools may cause scratches.
- Disposable cotton cosmetic swabs may contain contaminants harmful to optical glass.
- Cosmetic cotton may cause scratches or get caught in small gaps.
- Consumer eyeglass cleaning cloths may be pretreated with silicone harmful to optical glass.
- Aggressive cleaners like benzene, acetone, or spirits may damage the surface.



Optical cleaning liquid material safety data sheets

Read the MSDS for the optical cleaning liquid before cleaning your camera and/or optics. The MSDS provides important information including hazard identification, first aid measures, handling and storage, and PPE.

Cleaning Instructions



Workplace conditions:

- Perform all cleaning operations (lenses, optical filter, and sensor) in a dust-free clean-room.
- Avoid touching the optical components with your fingers or any hard material.
- Nitrile cleanroom gloves or powder free latex gloves are recommended to maintain low particulate levels.
- Use an ESD mat to prevent damage from an electrostatic discharge.

1. Unplug the camera from any power supply before cleaning.
2. Apply a small amount of cleaning liquid to a new lens cleaning cotton, cloth, or tissue. The cotton, cloth, or lens tissue should be moist, but not dripping.



3. Hold the camera sensor diagonally upwards. Ensure that the camera is away from your body to prevent particles like skin flakes from falling on the sensor.
4. Wipe the glass surface with a spiral motion from the center to the rim. Normally, several spiral wipes are recommended. Wipe only on glass avoiding contact to metal surfaces, because microscopic dirt could be released and could cause scratches on the glass.
5. When you have finished cleaning, examine the surface in a strong light. Take an out-of-focus picture of a flat, illuminated surface to see if any dirt or dust remains.
6. If dust spots remain, repeat this procedure using new clean lens tissue (as previously described).



If you notice that the camera lens or sensor is not clean after attempting to clean twice, or if you have any questions regarding cleaning your camera, contact your Allied Vision distribution partner.

Cleaning with compressed air

We do not recommend cleaning Mako G cameras with compressed air.

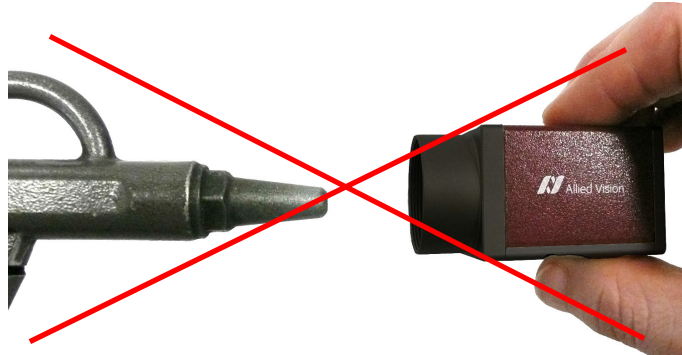

Figure 74: Cleaning with compressed air is not recommended



NOTICE

Possible material damage

- Compressed air at high pressure and/or shorter operating distances may push dust into the camera or lens and physically damage the camera, sensor, or optical components.
- Propellant from non-optic approved compressed air products may leave a residue on the camera or lens and may physically damage the camera, sensor, or optical components.
- Compressed air may contain oil or moisture that could contaminate or damage the optical components.
- Use an air blower or compressed air only if you are familiar with cleaning a camera using this method.

If you want to clean your camera with compressed air despite of all the warnings:

- Use an optic approved compressed air product or compressor.
- Use an anti-static ionizer attachment to reduce the risk of static-caused damage.
- Use a filter to remove moisture and oil from the air.
- Use short directed bursts of air to remove impurities.



Compressed air pressure and operating distance

- Keep the compressed air pressure at a moderate strength only. Pressure at the nozzle should be less than 100 kPa.
- Operating distance from the camera should be 5 to 30 cm.

Firmware update



This chapter includes instruction on how to update the firmware on your Mako G camera.



If new firmware contains a new feature or control, saved camera UserSets or ConfigFiles are invalidated and erased!

Before loading new firmware, backup your current camera settings.

- **Vimba Viewer:** select the **Save Camera Settings** icon from the **Cameras** window to export the camera settings file (XML) to the host computer.
- **GigE SampleViewer:** select the **Disk** icon from the **Cameras** window to export camera settings file (XML) to the host computer.



NOTICE

Do not unplug the GigE cable or camera power supply during the update procedure.

Updating the firmware on your Mako G camera

1. Launch the **Firmware Loader**.

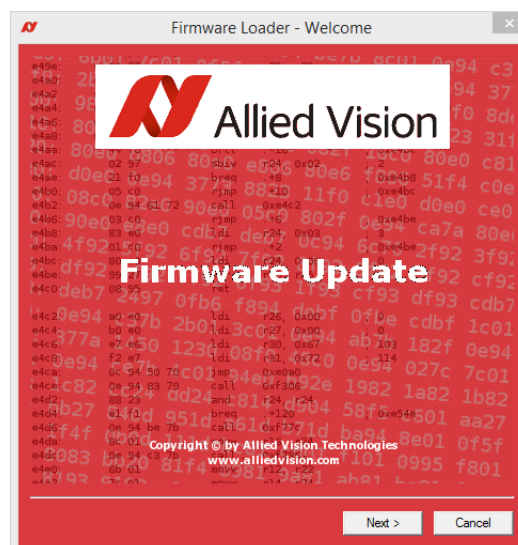

- Click **Next**. The **Firmware Loader** displays a list of firmware included in the package

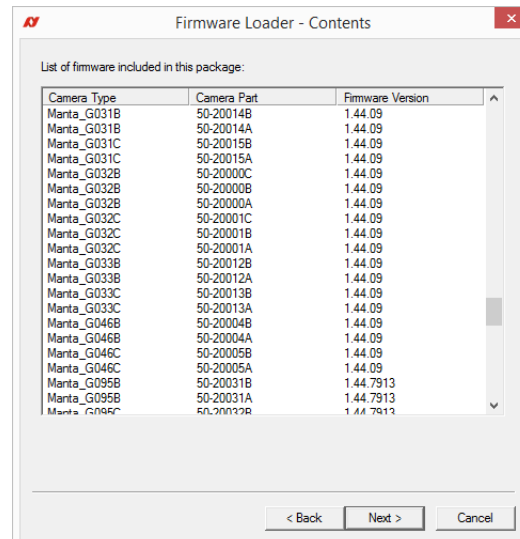

- Click **Next**. You can select your camera model on this page.

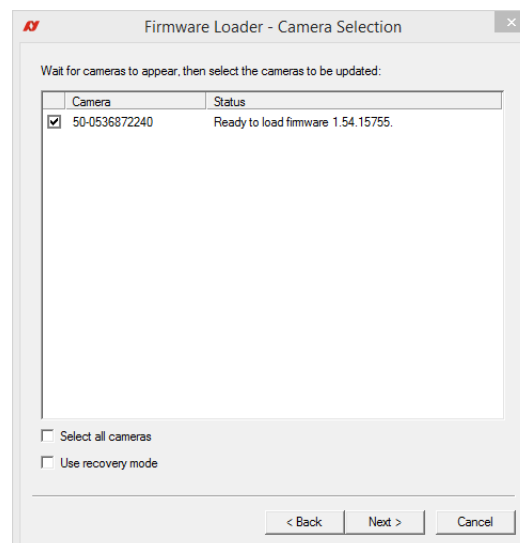

Select the **Use recovery mode** checkbox if the connected GigE camera is not found by the firmware loader, or if the GigE camera is listed as unavailable. When selected, power cycle the camera to enter the **Boot Loader** mode.

- Click **Next**.

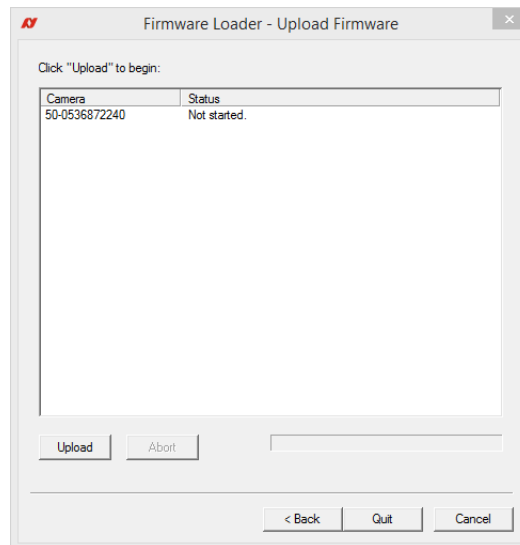

- Click **Upload** to start the update. The existing firmware is erased and the new firmware is uploaded to the camera.

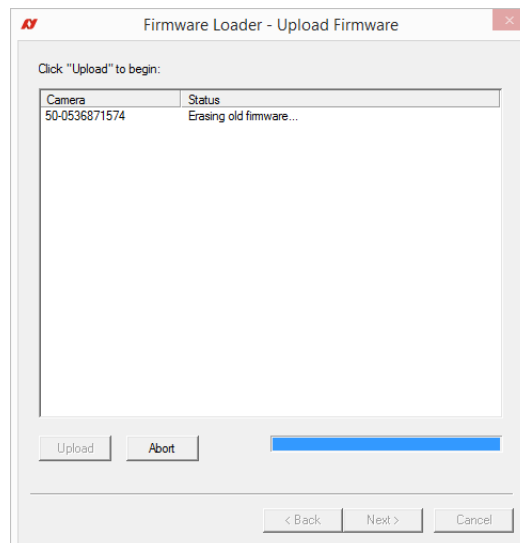

- The **Firmware Loader** displays a success status upon completion. Click **Quit** to exit the loader.

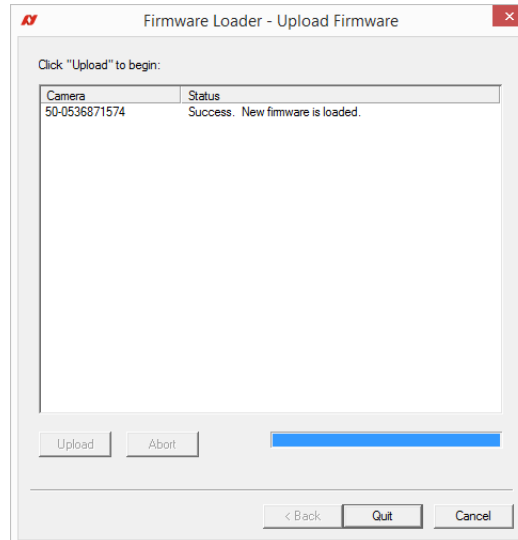

You should always power cycle the camera after a firmware upgrade or downgrade.

Index

A	
Acquisition stream	113
B	
Bandwidth	
RAW-mode	124
BAYER mosaic	124
BAYER to RGB	
Color interpretation	124
C	
Camera lenses	97
Category 6	27
Cleaning	
Compressed air	132
Instructions	131
Locating impurities	128
Materials	130
Color interpolation	
Color information	124
Compliance	
USA	17
Control signals	
Input block diagram	112
Copyright	20
Cross section	
C-Mount	93
CS-Mount	93
D	
Dimensional mount adjustment	95
Dimensions	31
Duration of sensor exposure	113
E	
electrostatic discharge	14
Environmental specifications	22
ESD	14
External trigger	113
F	
Feature comparison	88
Focal length	97
Frame memory	32
Frame readout	113
Frame trigger	113
G	
General purpose output	112
General safety notes	20
GenICam	31
Gigabit Ethernet	
Cable length	2
Cable type	107
IEEE 802.3 1000BASE-T	107
Interface	2
GigE Vision	31
GPO	112
I	
I/O	
Connector pin assignment	107
Control signals	112
IEEE 802.3af-2003	107
Input block diagram	112
Interline boundary	116
Interpolation	
BAYER demosaicing	125
BAYER to RGB	124
IR cut filter	
Hoya C5000	104
Isolated out power	111
L	
Logic trigger	113
M	
Mako G	
Back panel	106
Status LEDs	106
Tripod adapter	91

Mass	31	S	
Minimum pulse width	110	Sensor position accuracy	92
		Sensor row readout cycles	115
O		Specifications	31
Output		Spectral transmission	
block diagram	110	IR cut filter	104
switching times	111	Status LEDs	106
Output current	22	SyncIn1	
Output signal	112	External trigger	113
Acquiring	113		
AcquisitionTriggerReady	112	T	
Exposing	113	Trigger	
FrameReadout	113	Definitions	115
FrameTrigger	113	Exposure	115
FrameTriggerReady	113	Exposure start delay	115
Imaging	113	Idle	115
Strobe1	113	Imaging	115
SyncIn1	113	Interline time	115
SyncOutGpoLevels	112	Logic trigger	115
Output switching		Propagation delay	115
parameters	111	Readout	115
		Registered exposure time	115
P		Rules	115
PoE		Time delay	115
IEEE 802.3af-2003	107	Timing diagram	114
Power		Tpd	115
DC	28	Trigger jitter	115
		Trigger latency	115
R		Trigger ready	115
RAW mode	124	User trigger	115
ROI measurements	32	Tripod adapter	91
		V	
		Voltage	22