

Zyla-HF

Fibre-optic sCMOS

Ultrafast and high resolution
Indirect Detection

Key Specifications

- 100 fps & **New** 40 fps USB 3.0
- 5.5 MP high resolution sCMOS
- High throughput fibre-optic coupling
- Down to 1.2 e⁻ read noise
- **New** >30 lp/mm resolution with YAG:Ce or LuAG:Ce scintillators

Key Applications

- ✓ X-Ray Tomography
- ✓ Neutron Tomography
- ✓ X-Ray Plasma Diagnostics
- ✓ Transmission Electron Microscopy (TEM)
- ✓ X-Ray Imaging
- ✓ X-Ray Diffraction



Introducing Zyla-HF

Zyla Fibre Optic sCMOS- X-Ray Imaging at 100 fps



Andor's **Zyla-HF** outstanding design delivers the highest transmission and spatial resolution performance associated with state-of-the-art single fibre optic plate bonding, while also taking advantage of the very fast frame rate, ultra-low noise performance and exceptional field of view of the Zyla-HF.

Its compact format, multiple mounting points and modular input configuration for scintillators or Beryllium filter integration allow ease of integration into laboratory setup or integrator (OEM) systems.

This unique feature combination makes the Zyla-HF the perfect detector platform for applications including X-ray imaging & tomography, electron microscopy and picosecond/nanosecond X-ray imaging when coupled to streak tubes or open MCPs.

Features and Benefits

Feature	Benefit
Rapid frame rates	100 fps full frame sustained and NEW 40 fps USB 3.0 model
Fibre optic plate coupling *1	Direct bonding to the sCMOS sensor for maximum throughput. EMA statistical structure provides the lowest channel crosstalk
5.5 megapixel sensor format with high resolution and 6.5 µm pixels	Large 16.6 x 14 mm field of view
1.2 e ⁻ read noise	Lower detection limit than any CCD
Compact and light	Ideal for integration into space restrictive set-ups
Rolling and Global shutter	Maximum flexibility across all applications
Dual-Gain amplifiers	Extensive dynamic range of 25,000:1 @ 30 fps
ROI and pixel binning	User-definable ROI (1 pixel granularity) and hardware binning
Dynamic baseline clamp	Essential for quantitative accuracy of dynamic measurements
Hardware time stamp	FPGA generated time stamp with 25 ns accuracy
Modular input interface	Choice of high resolution / high throughput scintillators and Beryllium filters
NEW High resolution scintillator options	Fibre-optic plate coupled YAG:Ce or LuAG:Ce scintillators for high resolution imaging > 30 lp/mm CsI:TI options for high throughput requirements
Integrated in EPICS	Ease of operation in EPICS software-based facilities such as partner particle accelerators and other large scientific experiments

1 sCMOS technology: high speed AND low noise AND large field of view

Scientific CMOS overcomes the limitation of traditional slow-scan CCDs or interline technologies by offering simultaneously a large **16.6 x 14 mm (5.5 Megapixel) field of view with high resolution 6.5 µm pixel, 100 frames per second and ultralow 1.2 e- read noise.**

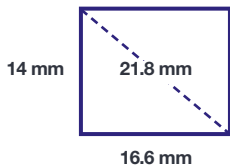

Left: Zyla 5.5-HF offers a wide field of view

Array Size	Zyla 5.5: 10-tap (USB 3.0)	
	Rolling Shutter	Global Shutter
2560 x 2160 (full frame)	100 (40)	49 (40)
2048 x 2048	105 (53)	52 (52)
1920 x 1080	200 (107)	97 (98)
512 x 512	422 (422)	201 (201)
128 x 128	1,691 (1,1691)	716 (716)

Above: Zyla 5.5-HF delivers exceptionally high frame rates in both Rolling Shutter and Global Shutter modes.

Learn more at: <http://www.andor.com/learning-academy/scmos-technology-what-is-scmos>

2 High resolution AND high throughput AND low crosstalk fibre-optic plate

- ✓ **Single fibre direct bonding onto sensor**
- ✓ **EMA (Extra-Mural Absorption) statistical structure**
Light-absorbing glass structures are inserted into the matrix as replacements for individual light-conducting fibres, absorbing stray photons not contained by the individual fibres and leading to the lowest fibre crosstalk.

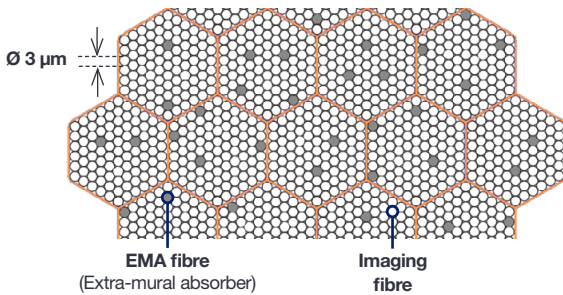

3 High spatial resolution

1:1 image of a USAF resolving Power Test Target 1951 acquired with a Zyla 5.5-HF (without scintillator, bare fibre optic plate) - features up to 50 lp/mm can be resolved

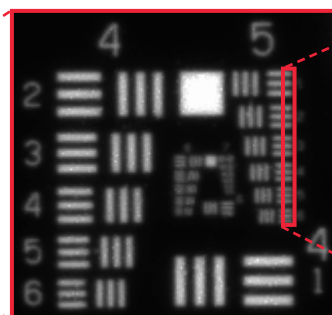
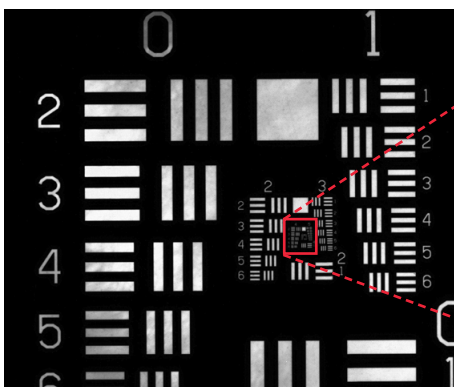

Cross section

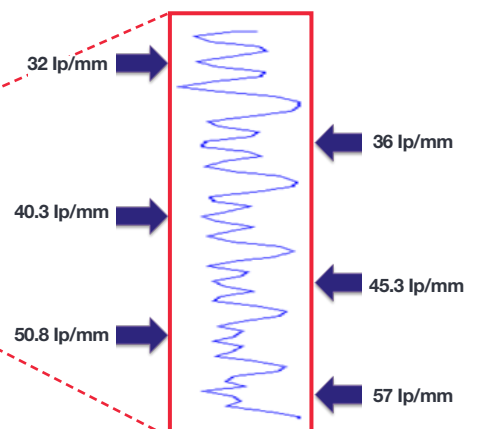

Technical Specifications

Sensor Specifications^{*2}

Sensor type	Front Illuminated Scientific CMOS with FOP
Sensor matrix ^{*3}	2560 x 2160 pixels (W x H) 6.5 µm pixel size
Image area	16.6 x 14.0 mm 21.8 mm
Blemish specification	Grade 1 sensor as per manufacturer definition
Maximum quantum efficiency ^{*4}	60% @ 580 nm

Advanced Performance Specifications^{*2}

Sensor Operating Temperature	0°C (up to 30°C ambient)		
Dark current, e ⁻ /pixel/sec @ min temp ^{*5}	0.14		
Pixel well depth	30,000 e ⁻		
Read noise (e ⁻) Median [rms] ^{*6}		Rolling Shutter	Global Shutter (snapshot)
	@ 200 MHz	1.2 [1.7]	2.4 [2.7]
	@ 560 MHz	1.45 [1.8]	2.6 [2.9]
Linearity ^{*7}	Better than 99.8% TBC		
Data range	12-bit and 16-bit		
Maximum dynamic range	25,000:1		
Pixel binning	Hardware Binning: 2 x 2, 3 x 3, 4 x 4, 8 x 8		
Trigger modes	Internal, External, External Start, External Exposure, Software Trigger		
Software Exposure Events ^{*8}	Start exposure - End exposure (row 1), Start exposure - End exposure (row n)		
Hardware timestamp accuracy	25 ns		
Anti-blooming factor	x 10,000		

Frame Rate Table - 12-Bit (16-Bit)^{*7}

Array Size	Zyla 5.5 USB 3.0		Zyla 5.5 10-tap	
	Rolling Shutter	Global Shutter	Rolling Shutter	Global Shutter
2560 x 2160	40 (30)	40 (30)	100 (75)	49 (49)
2048 x 2048	53 (40)	52 (39)	105 (98)	52 (52)
1920 x 1080	107 (80)	98 (80)	200 (200)	97 (97)
512 x 512	422 (422)	201 (201)	422 (422)	201 (201)
128 x 128	1691 (1691)	716 (716)	1691 (1691)	716 (716)

Fibre Optic Plate⁹

EMA Design	Statistical
Fibre Diameter	3 µm
Core : Cladding ratio	80 : 20
Image Distortion	Shear: sub 6.5 µm pixel Gross: sub 6.5 µm pixel

For more information please refer to page 3.

Sensor Quantum Efficiency Curve **

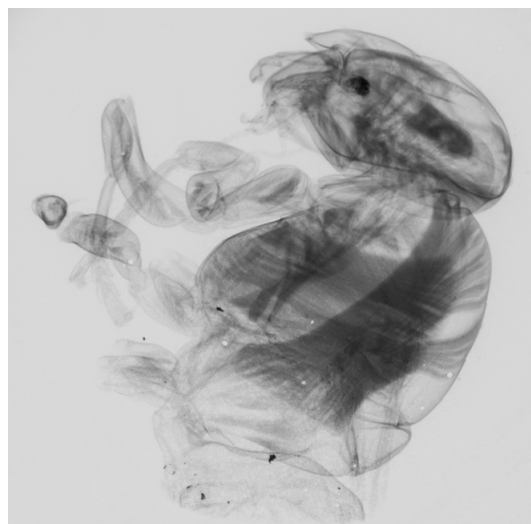
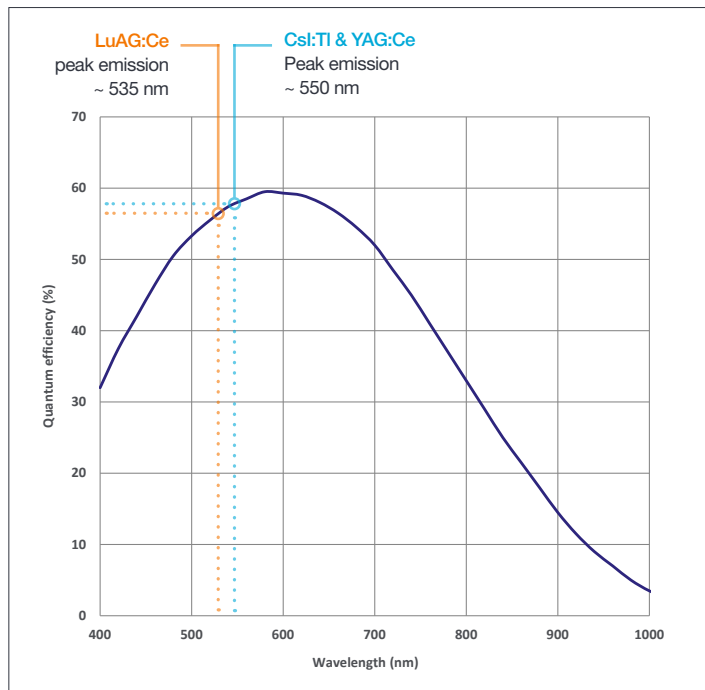

Image of a wasp acquired with a 20 µm thick YAG:Ce scintillator fibre-optic coupled to a Zyla HF (10 s exposure) X-ray source Cu target, 40 keV, 2 W Image courtesy of Crytur

Scintillator Specifications *10

Best resolution			Best resolution/throughput balance			Best throughput		
Scintillator characteristics	Spatial resolution *	Energy range	Scintillator	Spatial resolution *	Energy range	Scintillator characteristics	Spatial resolution *	Energy range
YAG:Ce 20 µm thick on 3 mm FOP	>30 lp/mm	Best suited for broad 2-100 keV range	YAG:Ce 70 µm thick on 3 mm FOP	~ 20 lp/mm	Best suited for broad 2-100 keV range	Csl:TI 150 µm thick on 3 mm FOP	~10 lp/mm	Best suited for 10-100 keV range
SCT-YAGCE -25-020-00			SCT-YAGCE -25-070-00					
LuAG:Ce 20 µm thick on 3 mm FOP	>30 lp/mm	Best suited for 10-100 keV range	LuAG:Ce 70 µm thick on 3 mm FOP	~ 20 lp/mm	Best suited for 10-100 keV range			
SCT-LUAGCE -25-020-00			SCT-LUAGCE -25-070-00					

*Spatial resolution is given at 10% MTF for the entire system Zyla HF, 1:1 fibre-optic plate and scintillator at 40 keV. Please note that spatial resolution will decrease at lower energies.



For more information about scintillator options please refer to the technical note: [Scintillators for Andor high energy detection cameras.](#)

Creating The Optimum Product for You



ZYLA-5.5 **X**-FO

example shown

Step 1. Select the camera type and connection

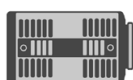

Camera Type

Description	Code
ZYLA 5.5-HF: 5.5 Megapixel scientific CMOS with FOP, Rolling and Global shutter modes, 100 fps, Camera Link 10-tap connection	ZYLA-5.5X-FO
ZYLA 5.5-HF: 5.5 Megapixel scientific CMOS with FOP, Rolling and Global shutter modes, 40 fps, USB 3.0 connection	ZYLA-5.5B-FO

Step 2. Select the required accessories



Accessories

Description	Order Code
Ø45.5 mm filter and Ø25.4 x3 mm scintillator holder for Zyla-HF	SCT-FLT_HLD-CC025ZYL
Beryllium filter, Ø45.5 mm, 250 µm thick	ACC-OPT-02839
Ø45.5 mm filter and 50 x 50 x 3 mm scintillator holder for Zyla-HF	SCT-FLT_HLD-H050ZYL
For further information about high resolution / high throughput scintillators characteristics and ordering information for Zyla HF, please refer to the technical note Scintillators for Andor high energy detection cameras	
5 m Camera Link connector cable. Order x2 if using with Zyla Camera Link 10-tap models.	ACC-ASE-02992
10 m active Camera Link connector cable, including power supply. For use with Zyla 10-tap Camera Link models.	ACC-ASE-06962
30 m fibre-optic extender solution for use with Zyla Camera Link 10-tap models.	ACC-ZYLFOX-10TAP-30M
100 m fibre-optic extender solution for use with Zyla Camera Link 10-tap models.	ACC-ZYLFOX-10TAP-100
15 m active USB 3.0 connector cable (power supply not required). For use with Zyla USB 3.0 models.	ACC-ASE-06887
50 m fibre optic USB 3.0 extender solution including power supply. For use with Zyla USB 3.0 models.	ACC-ASE-08762
100 m fibre optic USB 3.0 extender solution including power supply. For use with Zyla USB 3.0 models.	ACC-ASE-07860

For further information on PC workstations for Zyla, please refer to the technical note [PC Specifications for sCMOS](#)

Step 3. Select the required software



Software

The Zyla-HF also requires at least one of the following software options:

Solis for Imaging A 32-bit and fully 64-bit enabled application for Windows (Vista, 7 and 8) offering rich functionality for data acquisition and processing. AndorBasic provides macro language control of data acquisition, processing, display and export.

Andor SDK A software development kit that allows you to control the Andor range of cameras from your own application. Available as 32 and 64-bit libraries for Windows (Vista, 7 and 8), compatible with C/C++, C#, Delphi, VB6, VB.NET, LabVIEW and Matlab. Linux SDK compatible with C/C++.

Third party software compatibility Drivers are available so that the Zyla range can be operated through a large variety of third party imaging packages. See Andor web site for detail: <http://www.andor.com/software/>

Product drawings

Dimensions in mm [inches]

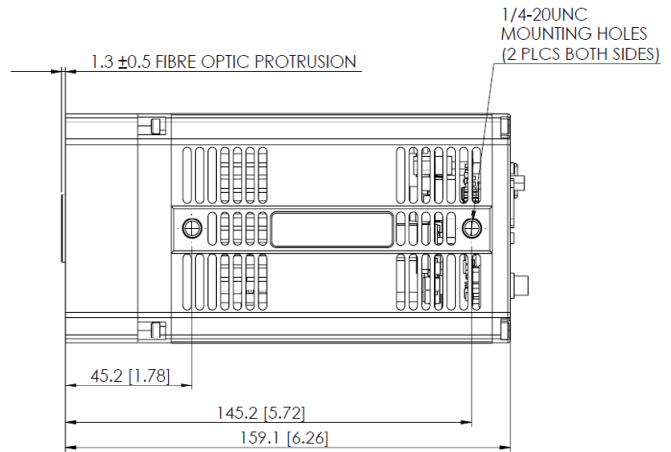
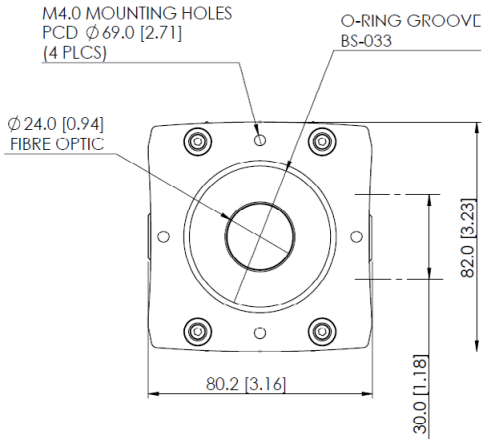
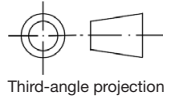

Weight: 1.25 kg [2 lb 12 oz]

Connections: Camera Link (Left) and USB 3.0 (right)

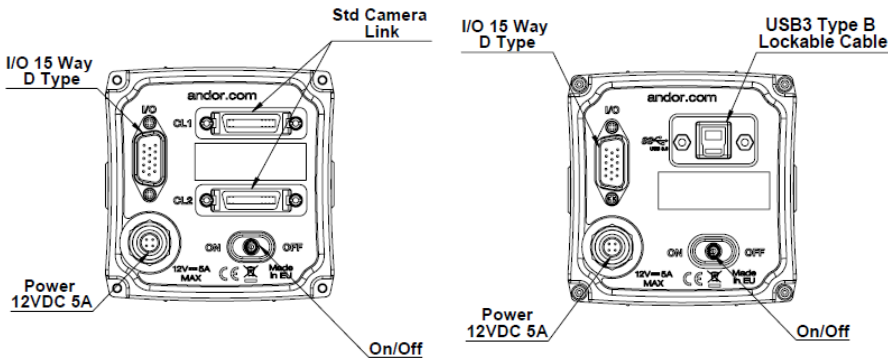

Notes

- Protective cap MEC-08309 not shown
- Optional Scintillator/Be Filter Holder is attached by M4 x 16 caphead screws (4 off).

Connecting to the Zyla

Camera Control

Connector type: 3 meter Camera Link 10-tap connectors or USB 3.0. (Longer lengths available as accessories).

TTL / Logic

Connector type: 15 way D Type with TTL I/Os for External Trigger, Frame Readout and Fire Pulse

Best Practice Guidelines

- ✓ Camera is susceptible to shock damage. The protective plate should always be fitted when the camera is not in use.
- ✓ The FOP should always be protected when mounting to another surface, both surfaces *must* be free of contamination to avoid damage.
- ✓ Dust or contamination can be removed by the drop and drag optical cleaning technique. For cleaning, use lens tissue with a suitable solvent e.g. spectroscopic grade solvent.
- ✗ When mounting a scintillator, do not apply a force exceeding 30 N onto the fibre optic surface.
- ✗ Do not use abrasives, corrosive solvents, avoid impact or point contact.
- ✗ Beryllium foil is very brittle in nature therefore extreme care should be taken to avoid shock damage. If the foil is broken there is a health risk. Please contact Andor for further information if required.

15-way D-type pinouts

1	ARM	Output
2	Aux_Out_1*	Output
3	FIRE row n	Output
4	FIRE row 1	Output
5	Aux_Out_2	Output
6	Ground	GND
7	External Trigger	Input
8	Spare Input	Input
9	Reserved	N/A
10	Reserved	N/A
11	Reserved	N/A
12	Reserved	N/A
13	Reserved	N/A
14	Reserved	N/A
15	Reserved	N/A

* Aux_Out_1 is configurable as Fire, Fire n, Fire All or Fire Any. Refer to the Zyla hardware manual.



Order Today

Need more information? At Andor we are committed to finding the correct solution for you. With a dedicated team of technical advisors, we are able to offer you one-to-one guidance and technical support on all Andor products. For a full listing of our regional sales offices, please see: www.andor.com/contact

Our regional headquarters are:

Europe

Belfast, Northern Ireland
Phone +44 (28) 9023 7126
Fax +44 (28) 9031 0792

Japan

Tokyo
Phone +81 (3) 6732 8968
Fax +81 (3) 6732 8939

North America

Concord, USA
Phone +1 (860) 290 9211
Fax +1 (860) 290 9566

China

Beijing
Phone +86 (10) 8271 9066
Fax +86 (10) 8271 9055

Items shipped with your camera:

For Camera Link 10-Tap Models: 1 x Camera Link Card and 2 x 3 meter connector cables.

For USB 3.0 models: 1 x USB 3.0 PCIe Card and 1 x 3 meter USB 3.0 cable (Type A to B)
1x Power supply with mains cable
1x 7-way Multi I/O timing cable, offering Fire, External Trigger and Arm (3 meter)
1x Quick Start Guide
1x CD containing Andor user guides
1x Individual system performance sheet
1x Protective cap (MEC-08309)

High resolution phase-contrast enhanced X-ray image of mouse paw (front page image)
Courtesy of 4DX Pty. Ltd., Melbourne, Australia.

Footnotes:

- Specifications are subject to change without notice
- IMPORTANT-Due to the sensor/ fibre optic being exposed to environments outside of Andor's control there is no warranty on the sensor. For full details of Andor's Warranty Policy please refer to our webpage at <http://www.andor.com/support>. Please refer to the best practice guidelines on page 7.
 - Figures are typical unless otherwise stated.
 - Edge pixels may exhibit a partial response.
 - Quantum efficiency of the sensor at 20°C as supplied by the sensor manufacturer.
 - Dark current measurement is averaged over the CCD area excluding any regions of blemishes.
 - Readout noise is for the entire system and is taken as a mean over the sensor area excluding any regions of blemishes. It is a combination of sensor readout noise and A/D noise.
 - Linearity is measured from a plot of counts vs exposure time under set photon flux up to the saturation point of the system.
 - Software Exposure Events provide rapid software notification (SDK only) of the start and end of acquisition, useful for tight synchronization to moving peripheral devices e.g. stages.
 - Data as supplied by the fibre optic plate manufacturer.
 - Data as supplied by the scintillator manufacturer. Scintillator peak emission at 550 nm. Please contact your local Andor representative to inquire about other scintillator options.

OXFORD
INSTRUMENTS

The Business of Science®

Minimum Computer Requirements:

- 2.68 GHz Quad Core
- 4GB RAM (increase RAM if to be used for continuous data spooling)
- Hard Drive:
Minimum 450 MB/s continuous write for USB 3.0 models
Minimum 850 MB/s continuous write for Camera Link 10-tap models
- PCI Express x4 or greater for USB 3.0 models
- PCI Express x8 or greater for Camera Link 10-tap models
- Windows (7 or 8) or Linux

* See technical note entitled: 'PC Specifications for sCMOS'

** Note, Andor supply PC workstations for Zyla, see page 8.

Operating & Storage Conditions

- Operating Temperature: 0°C to 30°C ambient
- Relative Humidity: < 70% (non-condensing)
- Storage Temperature: -10°C to 50°C

Power Requirements

- Power: +12 VDC ± 5% @ 5A
- Ripple: 200 mV peak-peak 0 - 20 MHz
- 100 - 240 VAC 50/60 Hz external power supply

External Power Supply Compliance

- UL-certified for Canada and USA
- Japanese PSE Mark



µManager

Windows is a registered trademark of Microsoft Corporation.
Labview is a registered trademark of National Instruments.
Matlab is a registered trademark of The MathWorks Inc.