

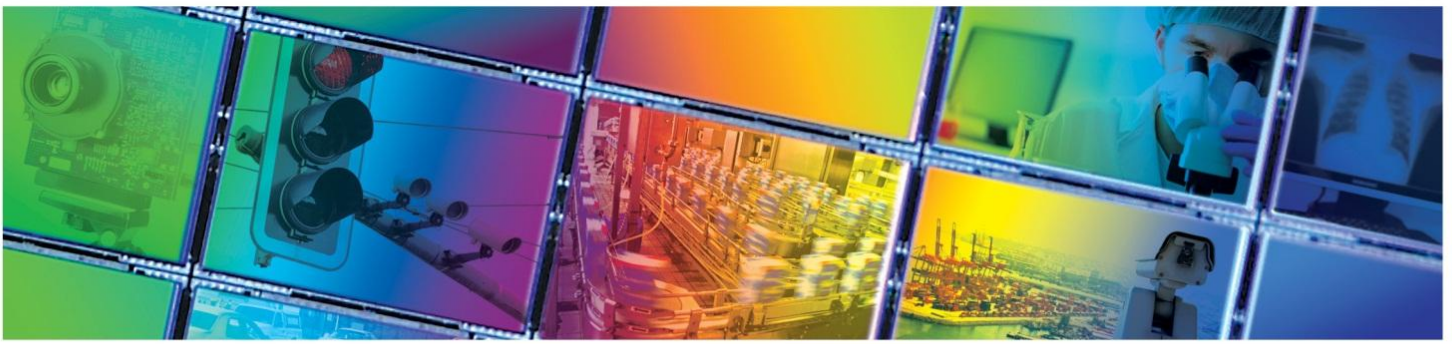

KAI-04022 IMAGE SENSOR
2048 (H) X 2048 (V) INTERLINE CCD IMAGE SENSOR



JUNE 22, 2012
DEVICE PERFORMANCE SPECIFICATION
REVISION 1.0 PS-0015

TABLE OF CONTENTS

Summary Specification	6
Description	6
Features	6
Applications	6
Ordering Information	7
Device Description	8
Architecture	8
Pixel.....	9
Vertical to Horizontal Transfer	10
Horizontal Register to Floating Diffusion	11
Horizontal Register Split.....	12
Single Output Operation	12
Dual Output Operation.....	12
Output.....	13
ESD Protection	15
Pin Description and Physical Orientation	16
Imaging Performance	17
Typical Operational Conditions.....	17
Specifications.....	17
All Configurations	17
KAI-04022-ABA Configuration	18
KAI-04022-CBA Configuration.....	18
Typical Performance Curves	19
Quantum Efficiency.....	19
Monochrome with Microlens.....	19
Monochrome without Microlens	19
Color (Bayer RGB) with Microlens	20
Angular Quantum Efficiency.....	21
Monochrome with Microlens.....	21
Dark Current versus Temperature	21
Power - Estimated	22
Frame Rates	22
Defect Definitions	23
Defect Map.....	23
Test Definitions	24
Test Regions of Interest	24
OverClocking	24
Tests.....	25
Dark Field Center Non-Uniformity	25
Dark Field Global Non-Uniformity.....	25
Global Non-Uniformity.....	25
Global Peak to Peak Non-Uniformity.....	25
Center Non-Uniformity	26
Dark Field Defect Test	26
Bright Field Defect Test.....	26
Operation.....	27
Maximum Ratings	27
Maximum Voltage Ratings Between Pins	27

DC Bias Operating Conditions.....	28
AC Operating Conditions.....	29
Clock Levels	29
Clock Line Capacitances.....	29
Timing Requirements	30
Timing Modes	31
Progressive Scan.....	31
Summed Interlaced Scan	32
Non-Summed Interlaced Scan	33
Frame Timing.....	34
Frame Timing without Binning – Progressive Scan.....	34
Frame Timing for Vertical Binning by 2 – Progressive Scan.....	34
Frame Timing Non-Summed Interlaced Scan (Even).....	35
Frame Timing Non-Summed Interlaced Scan (Odd).....	36
Frame Timing Summed Interlaced Scan (Even).....	37
Frame Timing Summed Interlaced Scan (Odd).....	38
Frame Timing Edge Alignment.....	39
Line Timing.....	40
Line Timing Single Output – Progressive Scan.....	40
Line Timing Dual Output – Progressive Scan.....	40
Line Timing Vertical Binning by 2 – Progressive Scan	41
Line Timing Detail – Progressive Scan.....	42
Line Timing Binning by 2 Detail – Progressive Scan.....	42
Line Timing Interlaced Modes	43
Line Timing Edge Alignment.....	44
Pixel Timing.....	45
Pixel Timing Detail	45
Fast Line Dump Timing.....	46
Electronic Shutter.....	47
Electronic Shutter Line Timing.....	47
Electronic Shutter – Integration Time Definition.....	47
Electronic Shutter – DC and AC Bias Definition.....	47
Electronic Shutter Description.....	48
Large Signal Output.....	49
Storage and Handling	50
Storage Conditions.....	50
ESD	50
Cover Glass Care and Cleanliness	50
Environmental Exposure	50
Soldering Recommendations	50
Mechanical Drawings	51
Completed Assembly.....	51
Die to Package Alignment.....	52
Glass.....	53
Glass Transmission	54
Quality Assurance and Reliability.....	55
Quality and Reliability	55
Replacement.....	55
Liability of the Supplier.....	55
Liability of the Customer	55

Test Data Retention.....	55
Mechanical.....	55
Life Support Applications Policy.....	55
Revision Changes.....	56
MTD/PS-1062.....	56
PS-0015	56

TABLE OF FIGURES

Figure 1: Sensor Architecture	8
Figure 2: Pixel Architecture.....	9
Figure 3: Vertical to Horizontal Transfer Architecture	10
Figure 4: Horizontal Register to Floating Diffusion Architecture	11
Figure 5: Horizontal Register	12
Figure 6: Output Architecture	13
Figure 7: ESD Protection	15
Figure 8: Package Pin Designations - Top View.....	16
Figure 9: Monochrome with Microlens Quantum Efficiency.....	19
Figure 10: Monochrome without Microlens Quantum Efficiency.....	19
Figure 11: Color Quantum Efficiency.....	20
Figure 12: Monochrome with Microlens Angular Quantum Efficiency	21
Figure 13: Dark Current versus Temperature	21
Figure 14: Power	22
Figure 15: Frame Rates.....	22
Figure 16: Overclock Regions of Interest	24
Figure 17: Output Amplifier	28
Figure 18: Clock Line Capacitances	29
Figure 19: Progressive Scan Operation	31
Figure 20: Progressive Scan Flow Chart	31
Figure 21: Summed Interlaced Scan Operation.....	32
Figure 22: Summed Interlaced Scan Flow Chart	32
Figure 23: Non- Summed Interlaced Scan Operation	33
Figure 24: Non- Summed Interlaced Scan Flow Chart	33
Figure 25: Framing Timing without Binning	34
Figure 26: Frame Timing for Vertical Binning by 2	34
Figure 27: Non-Summed Interlaced Scan Even Frame Timing	35
Figure 28: Non-Summed Interlaced Scan Odd Frame Timing	36
Figure 29: Summed Interlaced Scan Even Frame Timing	37
Figure 30: Summed Interlaced Scan Odd Frame Timing	38
Figure 31: Frame Timing Edge Alignment	39
Figure 32: Line Timing Single Output	40
Figure 33: Line Timing Dual Output	40
Figure 34: Line Timing Vertical Binning by 2.....	41
Figure 35: Line Timing Detail	42
Figure 36: Line Timing by 2 Detail	42
Figure 37: Line Timing Interlaced Modes.....	43
Figure 38: Line Timing Edge Alignment	44
Figure 39: Pixel Timing	45
Figure 40: Pixel Timing Detail	45
Figure 41: Fast Line Dump Timing	46
Figure 42: Electronic Shutter Line Timing	47
Figure 43: Integration Time Definition.....	47
Figure 44: Completed Assembly	51
Figure 45: Die to Package Alignment	52
Figure 46: Glass Drawing.....	53
Figure 47: Glass Transmission	54

Summary Specification

KAI-04022 Image Sensor

DESCRIPTION

The KAI-04022 Image Sensor is a high-performance 4-million pixel sensor designed for a wide range of medical, scientific and machine vision applications. The 7.4 μm square pixels with microlenses provide high sensitivity and the large full well capacity results in high dynamic range. The two high-speed outputs and binning capabilities allow for 16-50 frames per second (fps) video rate for the progressively scanned images. The vertical overflow drain structure provides antiblooming protection and enables electronic shuttering for precise exposure control. Other features include low dark current, negligible lag and low smear.

FEATURES

- High resolution
- High sensitivity
- High dynamic range
- Low noise architecture
- High frame rate
- Binning capability for higher frame rate
- Electronic shutter

APPLICATIONS

- Intelligent Transportation Systems
- Machine Vision
- Scientific Imaging
- Surveillance

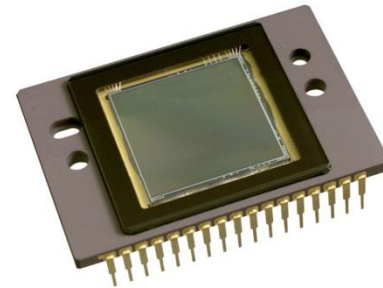

Parameter	Value
Architecture	Interline CCD; Progressive Scan
Total Number of Pixels	2112 (H) x 2072 (V)
Number of Effective Pixels	2056 (H) x 2062 (V)
Number of Active Pixels	2048 (H) x 2048 (V)
Pixel Size	7.4 μm (H) x 7.4 μm (V)
Active Image Size	15.15mm (H) x 15.15mm (V) 21.43mm (diagonal)
Aspect Ratio	1:1
Number of Outputs	1 or 2
Charge Capacity	40,000 e^-
Output Sensitivity	33 $\mu\text{V}/e^-$
Peak Quantum Efficiency	
KAI-04022-ABA	55%
KAI-04022-CBA (BGR)	45%, 42%, 35%
Read Noise (f=10MHz)	9 electrons, rms
Dark Current	< 0.5 nA/cm ²
Dark Current Doubling Temperature	7 °C
Dynamic Range	72 dB
Charge Transfer Efficiency	> 0.99999
Blooming Suppression	300X
Smear	-80 dB
Image Lag	<10 e^-
Maximum Frame Rates	8 fps (single output) 16 fps (dual output)
Package	34 pin cerDIP
Cover Glass	AR Coated, 2 side

All parameters above are specified at T = 40 °C

Ordering Information

Catalog Number	Product Name	Description	Marking Code
4H0957	KAI-04022-AAA-CR-BA	Monochrome, No Microlens, CERDIP Package (sidebrazed), Taped Clear Cover Glass with AR coating (2 sides), Standard Grade	KAI-04022-AAA Serial Number
4H0958	KAI-04022-AAA-CR-AE	Monochrome, No Microlens, CERDIP Package (sidebrazed), Taped Clear Cover Glass with AR coating (2 sides), Engineering Grade	
4H0959	KAI-04022-ABA-CD-BA	Monochrome, Telecentric Microlens, CERDIP Package (sidebrazed), Clear Cover Glass with AR coating (2 sides), Standard Grade	KAI-04022-ABA Serial Number
4H0960	KAI-04022-ABA-CD-AE	Monochrome, Telecentric Microlens, CERDIP Package (sidebrazed), Clear Cover Glass with AR coating (2 sides), Engineering Grade	
4H0961	KAI-04022-ABA-CR-BA	Monochrome, Telecentric Microlens, CERDIP Package (sidebrazed), Taped Clear Cover Glass with AR coating (2 sides), Standard Grade	
4H0962	KAI-04022-ABA-CR-AE	Monochrome, Telecentric Microlens, CERDIP Package (sidebrazed), Taped Clear Cover Glass with AR coating (2 sides), Engineering Grade	
4H0963	KAI-04022-CBA-CD-BA	Color (Bayer RGB), Telecentric Microlens, CERDIP Package (sidebrazed), Clear Cover Glass with AR coating (2 sides), Standard Grade	KAI-04022-CBA Serial Number
4H0964	KAI-04022-CBA-CD-AE	Color (Bayer RGB), Telecentric Microlens, CERDIP Package (sidebrazed), Clear Cover Glass with AR coating (2 sides), Engineering Grade	
4H0965	KAI-04022-CBA-CR-BA	Color (Bayer RGB), Telecentric Microlens, CERDIP Package (sidebrazed), Taped Clear Cover Glass with AR coating (2 sides), Standard Grade	
4H0966	KAI-04022-CBA-CR-AE	Color (Bayer RGB), Telecentric Microlens, CERDIP Package (sidebrazed), Taped Clear Cover Glass with AR coating (2 sides), Engineering Grade	

See Application Note *Product Naming Convention* for a full description of the naming convention used for Truesense Imaging image sensors. For reference documentation, including information on evaluation kits, please visit our web site at www.truesenseimaging.com.

Please address all inquiries and purchase orders to:

Truesense Imaging, Inc.
 1964 Lake Avenue
 Rochester, New York 14615

Phone: (585) 784-5500
 E-mail: info@truesenseimaging.com

Truesense Imaging reserves the right to change any information contained herein without notice. All information furnished by Truesense Imaging is believed to be accurate.

Device Description

ARCHITECTURE

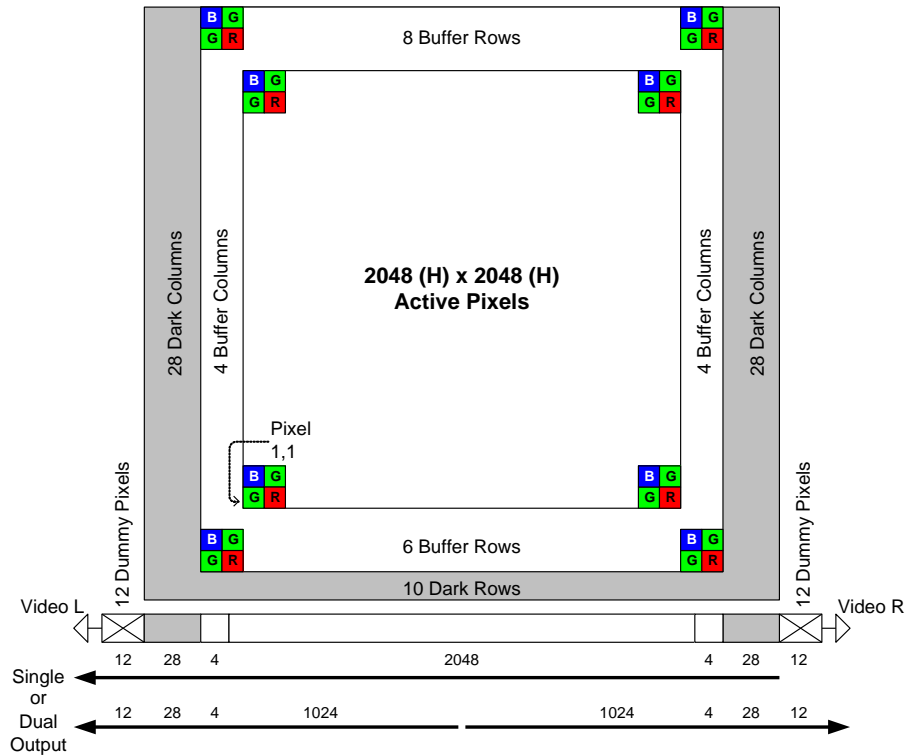

Figure 1: Sensor Architecture

There are 10 light shielded rows followed 2062 photoactive rows. The first 6 and the last 8 photoactive rows are buffer rows giving a total of 2048 lines of image data.

In the single output mode all pixels are clocked out of the Video L output in the lower left corner of the sensor. The first 12 empty pixels of each line do not receive charge from the vertical shift register. The next 28 pixels receive charge from the left light-shielded edge followed by 2056 photo-sensitive pixels and finally 28 more light shielded pixels from the right edge of the sensor. The first and last 4 photosensitive pixels are buffer pixels giving a total of 2048 pixels of image data.

In the dual output mode the clocking of the right half of the horizontal CCD is reversed. The left half of the image is clocked out Video L and the right half of the image is clocked out Video R. Each row consists of 12 empty pixels followed by 28 light shielded pixels followed by 1028 photosensitive pixels. When reconstructing the image, data from Video R will have to be reversed in a line buffer and appended to the Video L data.

There are no dark reference rows at the top and 10 dark rows at the bottom of the image sensor. The 10 dark rows are not entirely dark and so should not be used for a dark reference level. Use the 28 dark columns on the left or right side of the image sensor as a dark reference.

Of the 28 dark columns, the first and last dark columns should not be used for determining the zero signal level. Some light does leak into the first and last dark columns. Only use the center 26 columns of the 28 column dark reference.

PIXEL

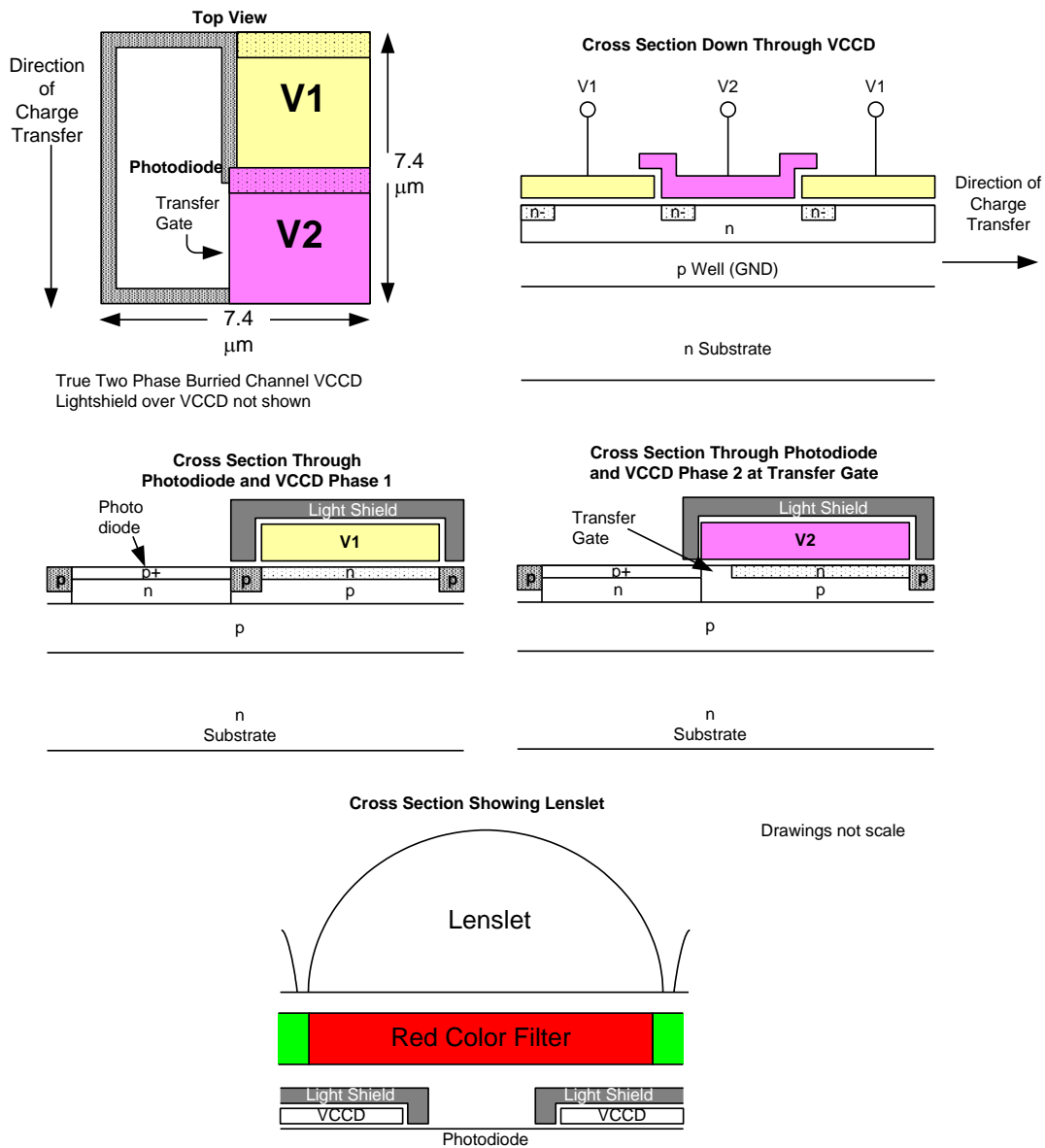

Figure 2: Pixel Architecture

An electronic representation of an image is formed when incident photons falling on the sensor plane create electron-hole pairs within the individual silicon photodiodes. These photoelectrons are collected locally by the formation of potential wells at each photosite. Below photodiode saturation, the number of photoelectrons collected at each pixel is linearly dependent upon light level and exposure time and non-linearly dependent on wavelength. When the photodiodes charge capacity is reached, excess electrons are discharged into the substrate to prevent blooming.

VERTICAL TO HORIZONTAL TRANSFER

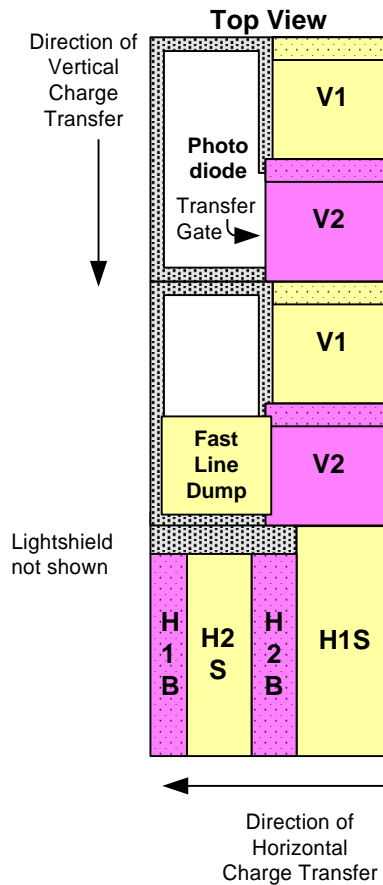

Figure 3: Vertical to Horizontal Transfer Architecture

When the V1 and V2 timing inputs are pulsed, charge in every pixel of the VCCD is shifted one row towards the HCCD. The last row next to the HCCD is shifted into the HCCD. When the VCCD is shifted, the timing signals to the HCCD must be stopped. H1 must be stopped in the high state and H2 must be stopped in the low state. The HCCD clocking may begin T_{HD} μ s after the falling edge of the V1 and V2 pulse.

Charge is transferred from the last vertical CCD phase into the H1S horizontal CCD phase. Refer to Figure 35 for an example of timing that accomplishes the vertical to horizontal transfer of charge.

If the fast line dump is held at the high level (FDH) during a vertical to horizontal transfer, then the entire line is removed and not transferred into the horizontal register.

HORIZONTAL REGISTER TO FLOATING DIFFUSION

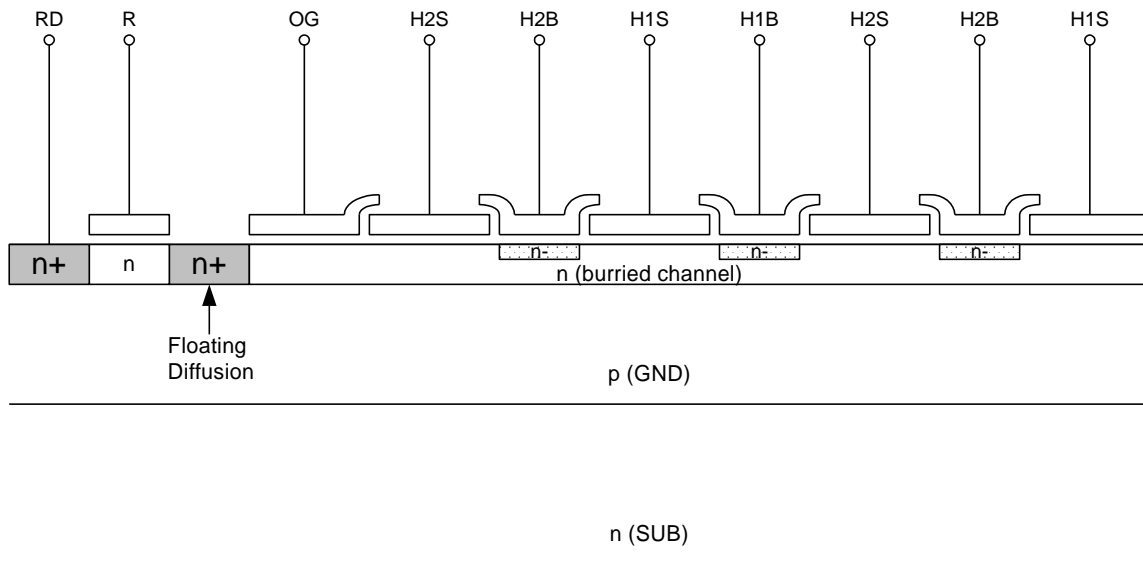

Figure 4: Horizontal Register to Floating Diffusion Architecture

The HCCD has a total of 2124 pixels. The 2112 vertical shift registers (columns) are shifted into the center 2112 pixels of the HCCD. There are 12 pixels at both ends of the HCCD, which receive no charge from a vertical shift register. The first 12 clock cycles of the HCCD will be empty pixels (containing no electrons). The next 28 clock cycles will contain only electrons generated by dark current in the VCCD and photodiodes. The next 2056 clock cycles will contain photoelectrons (image data). Finally, the last 28 clock cycles will contain only electrons generated by dark current in the VCCD and photodiodes. Of the 28 dark columns, the first and last dark columns should not be used for determining the zero signal level. Some light does leak into the first and last dark columns. Only use the center 26 columns of the 28 column dark reference.

When the HCCD is shifting valid image data, the timing inputs to the electronic shutter (SUB), VCCD (V1, V2), and fast line dump (FD) should be not be pulsed. This prevents unwanted noise from being introduced. The HCCD is a type of charge coupled device known as a pseudo-two phase CCD. This type of CCD has the ability to shift charge in two directions. This allows the entire image to be shifted out to the video L output, or to the video R output (left/right image reversal). The HCCD is split into two equal halves of 1068 pixels each. When operating the sensor in single output mode the two halves of the HCCD are shifted in the same direction. When operating the sensor in dual output mode the two halves of the HCCD are shifted in opposite directions. The direction of charge transfer in each half is controlled by the H1BL, H2BL, H1BR, and H2BR timing inputs.

HORIZONTAL REGISTER SPLIT

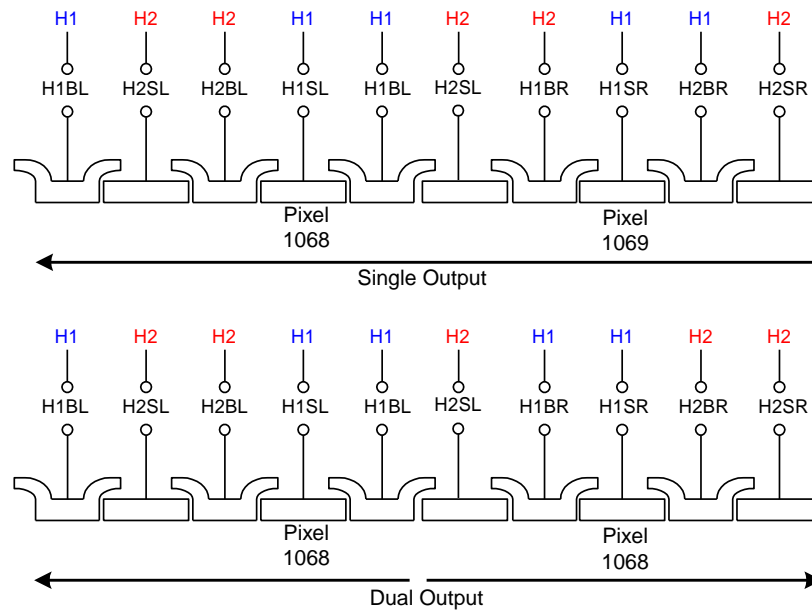

Figure 5: Horizontal Register

Single Output Operation

When operating the sensor in single output mode all pixels of the image sensor will be shifted out the Video L output (pin 12). To conserve power and lower heat generation the output amplifier for Video R may be turned off by connecting VDDR (pin 24) and VOUTR (pin 23) to GND (zero volts).

The H1 timing from the timing diagrams should be applied to H1SL, H1BL, H1SR, H2BR, and the H2 timing should be applied to H2SL, H2BL, H2SR, and H1BR. In other words, the clock driver generating the H1 timing should be connected to pins 16, 15, 19, and 21. The clock driver generating the H2 timing should be connected to pins 17, 14, 18, and 20. The horizontal CCD should be clocked for 12 empty pixels plus 28 light shielded pixels plus 2056 photoactive pixels plus 28 light shielded pixels for a total of 2124 pixels.

Dual Output Operation

In dual output mode the connections to the H1BR and H2BR pins are swapped from the single output mode to change the direction of charge transfer of the right side horizontal shift register. In dual output mode both VDDL and VDDR (pins 11, 24) should be connected to 15 V. The H1 timing from the timing diagrams should be applied to H1SL, H1BL, H1SR, H1BR, and the H2 timing should be applied to H2SL, H2BL, H2SR, and H2BR. The clock driver generating the H1 timing should be connected to pins 16, 15, 19, and 20. The clock driver generating the H2 timing should be connected to pins 17, 14, 18, and 21. The horizontal CCD should be clocked for 12 empty pixels plus 28 light shielded pixels plus 1028 photoactive pixels for a total of 1068 pixels. If the camera is to have the option of dual or single output mode, the clock driver signals sent to H1BR and H2BR may be swapped by using a relay. Another alternative is to have two extra clock drivers for H1BR and H2BR and invert the signals in the timing logic generator. If two extra clock drivers are used, care must be taken to ensure the rising and falling edges of the H1BR and H2BR clocks occur at the same time (within 3 ns) as the other HCCD clocks.

OUTPUT

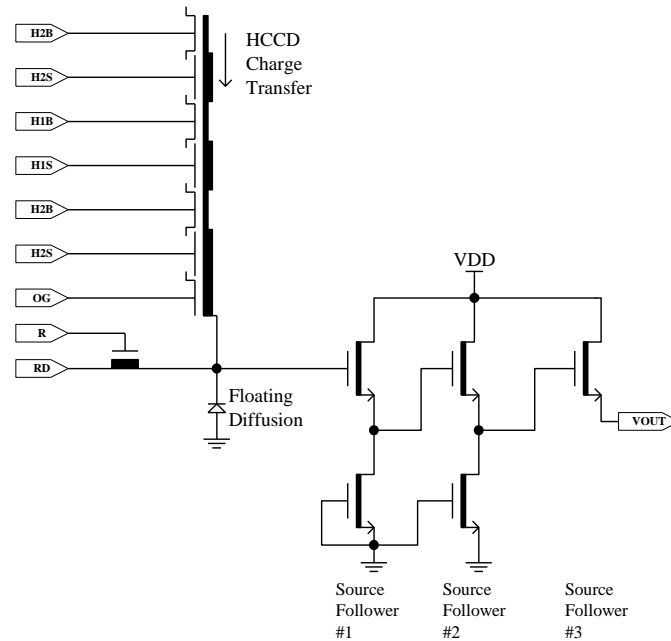

Figure 6: Output Architecture

Charge packets contained in the horizontal register are dumped pixel by pixel onto the floating diffusion (fd) output node whose potential varies linearly with the quantity of charge in each packet. The amount of potential charge is determined by the expression $\Delta V_{fd} = \Delta Q / C_{fd}$. A three-stage source-follower amplifier is used to buffer this signal voltage off chip with slightly less than unity gain. The translation from the charge domain to the voltage domain is quantified by the output sensitivity or charge to voltage conversion in terms of microvolts per electron ($\mu V/e^-$). After the signal has been sampled off chip, the reset clock (R) removes the charge from the floating diffusion and resets its potential to the reset drain voltage (RD).

When the image sensor is operated in the binned or summed interlaced modes there will be more than 20,000 electrons in the output signal. The image sensor is designed with a $31 \mu V/e^-$ charge to voltage conversion on the output. This means a full signal of 20,000 electrons will produce a 640 mV change on the output amplifier. The output amplifier was designed to handle an output swing of 640 mV at a pixel rate of 40 MHz. If 40,000 electron charge packets are generated in the binned or summed interlaced modes then the output amplifier output will have to swing 1280 mV. The output amplifier does not have enough bandwidth (slew rate) to handle 1280 mV at 40 MHz. Hence, the pixel rate will have to be reduced to 20 MHz if the full dynamic range of 40,000 electrons is desired.

The charge handling capacity of the output amplifier is also set by the reset clock voltage levels. The reset clock driver circuit is very simple, if an amplitude of 5 V is used. But the 5V amplitude restricts the output amplifier charge capacity to 20,000 electrons. If the full dynamic range of 40,000 electrons is desired then the reset clock amplitude will have to be increased to 7 V.

If you only want a maximum signal of 20,000 electrons in binned or summed interlaced modes, then a 40 MHz pixel rate with a 5 V reset clock may be used. The output of the amplifier will be unpredictable above 20,000 electrons so be sure to set the maximum input signal level of your analog to digital converter to the equivalent of 20,000 electrons (640 mV).

The following table summarizes the previous explanation on the output amplifier’s operation. Certain trade-offs can be made based on application needs such as Dynamic Range or Pixel frequency.

Pixel Freq. (MHz)	Reset Clock Amplitude (V)	Output Gate (V)	Saturation Signal (mV)	Saturation Signal (ke ⁻)	Notes
40	5	-2	640	20	
20	5	-2	640	20	
20	7	-3	1280	40	
20	7	-3	2560	80	1

Notes:

1. 80,000 electrons achievable in summed interlaced or binning modes.

ESD PROTECTION

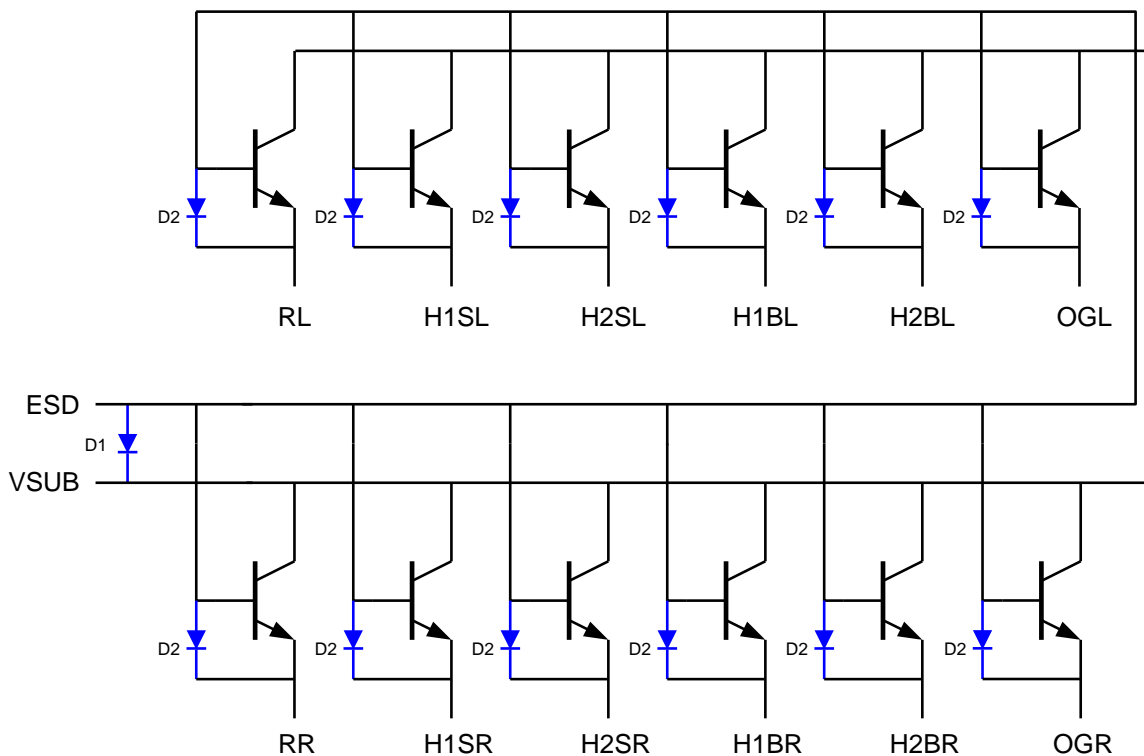

Figure 7: ESD Protection

The ESD protection on the KAI-04022 is implemented using bipolar transistors. The substrate (VSUB) forms the common collector of all the ESD protection transistors. The ESD pin is the common base of all the ESD protection transistors. Each protected pin is connected to a separate emitter as shown in Figure 7.

The ESD circuit turns on if the base-emitter junction voltage exceeds 17 V. Care must be taken while operating the image sensor, especially during the power on sequence, to not forward bias the base-emitter or base-collector junctions. If it is possible for the camera power up sequence to forward bias these junctions then diodes D1 and D2 should be added to protect the image sensor. Put one diode D1 between the ESD and VSUB pins. Put one diode D2 on each pin that may forward bias the base-emitter junction. The diodes will prevent large currents from flowing through the image sensor. Note that external diodes D1 and D2 are optional and are only needed if it is possible to forward bias any of the junctions.

Note that diodes D1 and D2 are added external to the KAI-04022.

PIN DESCRIPTION AND PHYSICAL ORIENTATION

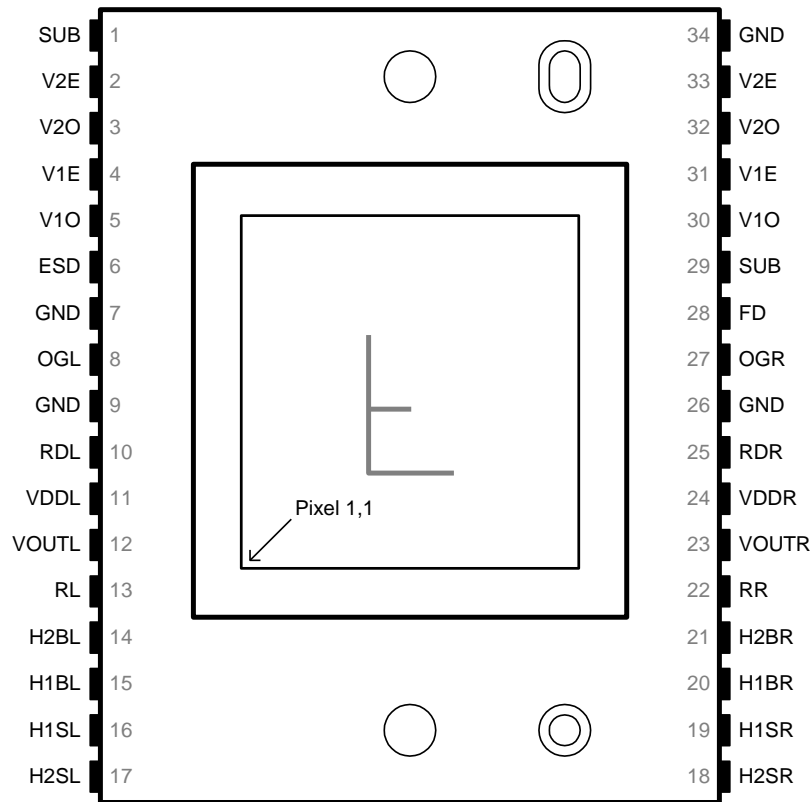

Figure 8: Package Pin Designations - Top View

Pin	Name	Description
1	SUB	Substrate
2	V2E	Vertical Clock, Phase 2, Even
3	V2O	Vertical Clock, Phase 2, Odd
4	V1E	Vertical Clock, Phase 1, Even
5	V1O	Vertical Clock, Phase 1, Odd
6	ESD	ESD
7	GND	Ground
8	OGL	Output Gate, Left
9	GND	Ground
10	RDL	Reset Drain, Left
11	VDDL	Vdd, Left
12	VOU TL	Video Output, Left
13	RL	Reset Gate, Left
14	H2BL	H2 Barrier, Left
15	H1BL	H1 Barrier, Left
16	H1SL	H1 Storage, Left
17	H2SL	H2 Storage, Left

Pin	Name	Description
34	GND	Ground
33	V2E	Vertical Clock, Phase 2, Even
32	V2O	Vertical Clock, Phase 2, Odd
31	V1E	Vertical Clock, Phase 1, Even
30	V1O	Vertical Clock, Phase 1, Odd
29	SUB	Substrate
28	FD	Fast Line Dump Gate
27	OGR	Output Gate, Right
26	GND	Ground
25	RDR	Reset Drain, Right
24	VDDR	Vdd, Right
23	VOU TR	Video Output, Right
22	RR	Reset Gate, Right
21	H2BR	H2 Barrier, Right
20	H1BR	H1 Barrier, Right
19	H1SR	H1 Storage, Right
18	H2SR	H2 Storage, Right

The pins are on a 0.070" spacing

Imaging Performance

TYPICAL OPERATIONAL CONDITIONS

Unless otherwise noted, the Imaging Performance Specifications are measured using the following conditions.

Description	Condition	Notes
Frame Time	538 msec	1
Horizontal Clock Frequency	10 MHz	
Light Source	Continuous red, green and blue illumination centered at 450, 530 and 650 nm	2,3
Operation	Nominal operating voltages and timing	

Notes:

1. Electronic shutter is not used. Integration time equals frame time.
2. LEDs used: Blue: Nichia NLPB500, Green: Nichia NSPG500S and Red: HP HLMP-8115.
3. For monochrome sensor, only green LED used.

SPECIFICATIONS

All Configurations

Description	Symbol	Min.	Nom.	Max.	Units	Verification Plan	Temperature Tested At (°C)	Notes
Dark Center Non-Uniformity		n/a	n/a	2	mVrms	Die	27, 40	
Dark Global Non-Uniformity		n/a	n/a	5.0	mVpp	Die	27, 40	
Global Non-Uniformity		n/a	2.5	5.0	%rms	Die	27, 40	1
Global Peak to Peak Non-Uniformity	PRNU	n/a	10	20	%pp	Die	27, 40	1
Center Non-Uniformity		n/a	1.0	2.0	%rms	Die	27, 40	1
Maximum Photoresponse Nonlinearity	NL	n/a	2		%	Design		2, 3
Maximum Gain Difference Between Outputs	ΔG	n/a	10		%	Design		2, 3
Max. Signal Error due to Nonlinearity Dif.	ΔNL	n/a	1		%	Design		2, 3
Horizontal CCD Charge Capacity	HNe		100		ke ⁻	Design		
Vertical CCD Charge Capacity	VNe	50	60		ke ⁻	Die		
Photodiode Charge Capacity	PNe	38	40		ke ⁻	Die		
Horizontal CCD Charge Transfer Efficiency	HCTE	0.99999		n/a		Design		
Vertical CCD Charge Transfer Efficiency	VCTE	0.99999		n/a		Design		
Photodiode Dark Current	I _{pd}	n/a	40	350	e/p/s	Die		
Photodiode Dark Current	I _{pd}	n/a	0.01	0.1	nA/cm ²	Die		
Vertical CCD Dark Current	I _{vd}	n/a	400	1711	e/p/s	Die		
Vertical CCD Dark Current	I _{vd}	n/a	0.12	0.5	nA/cm ²	Die		
Image Lag	Lag	n/a	<10	50	e ⁻	Design		
Antiblooming Factor	X _{ab}	100	300	n/a				
Vertical Smear	Smr	n/a	-80	-75	dB			
Read Noise	n _{e-T}		9		e ⁻ rms	Design		4
Dynamic Range	DR		72		dB	Design		4, 5
Output Amplifier DC Offset	V _{odc}	4	8.5	14	V	Die		
Output Amplifier Bandwidth	F _{-3db}		140		MHz	Design		
Output Amplifier Impedance	R _{OUT}	100	130	200	Ohms	Die		
Output Amplifier Sensitivity	$\Delta V/\Delta N$		31		μV/e ⁻	Design		

KAI-04022-ABA Configuration

Description	Symbol	Min.	Nom.	Max.	Units	Verification Plan	Temperature Tested At (°C)	Notes
Peak Quantum Efficiency	QE _{max}	45	55	n/a	%	Design		
Peak Quantum Efficiency Wavelength	λQE	XXX	500	n/a	nm	Design		

KAI-04022-CBA Configuration

Description	Symbol	Min.	Nom.	Max.	Units	Verification Plan	Temperature Tested At (°C)	Notes
Peak Quantum Efficiency	Blue Green Red QE _{max}		45 42 35	n/a n/a n/a	%	Design		
Peak Quantum Efficiency Wavelength	Blue Green Red λQE		470 540 620	n/a n/a n/a	nm	Design		

n/a: not applicable

Notes:

1. Per color.
2. Value is over the range of 10% to 90% of photodiode saturation.
3. Value is for the sensor operated without binning
4. At 10 MHz.
5. Uses 20LOG(PNe/n_{e-T})

Typical Performance Curves

QUANTUM EFFICIENCY

Monochrome with Microlens

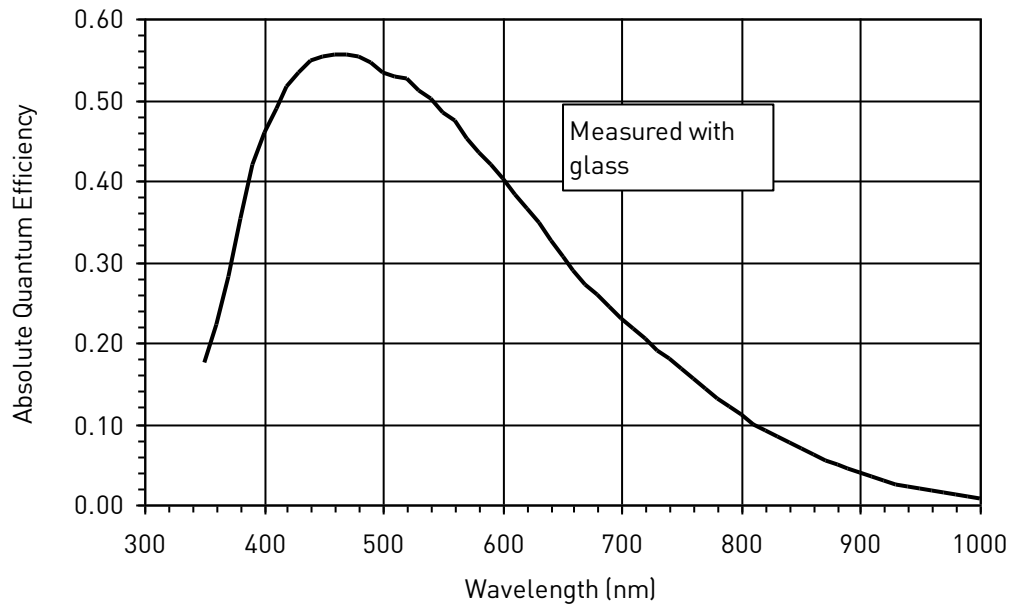

Figure 9: Monochrome with Microlens Quantum Efficiency

Monochrome without Microlens

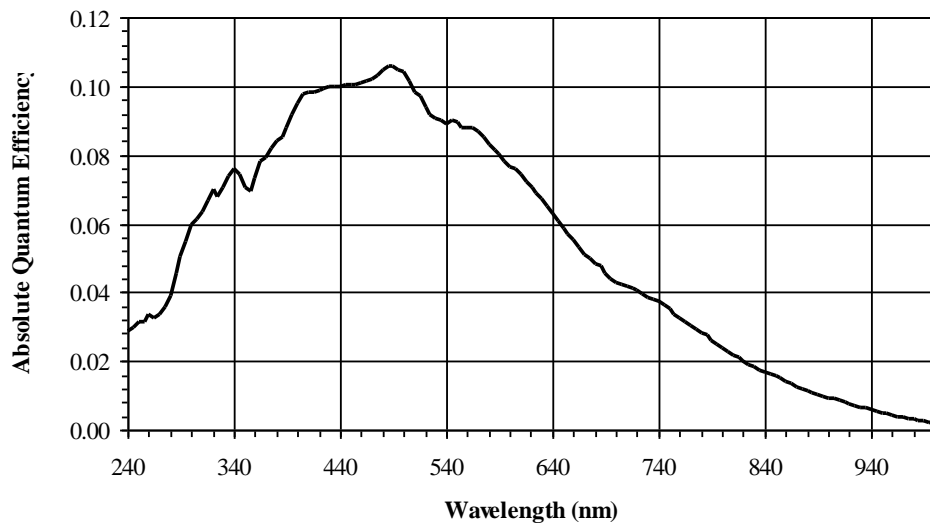

Figure 10: Monochrome without Microlens Quantum Efficiency

Color (Bayer RGB) with Microlens

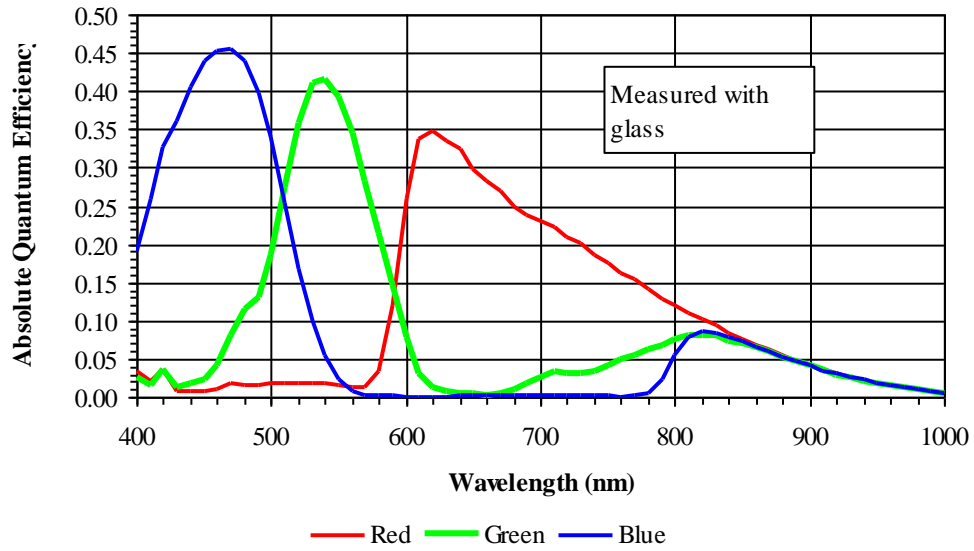

Figure 11: Color Quantum Efficiency

Angular Quantum Efficiency

For the curves marked "Horizontal", the incident light angle is varied in a plane parallel to the HCCD.

For the curves marked "Vertical", the incident light angle is varied in a plane parallel to the VCCD.

Monochrome with Microlens

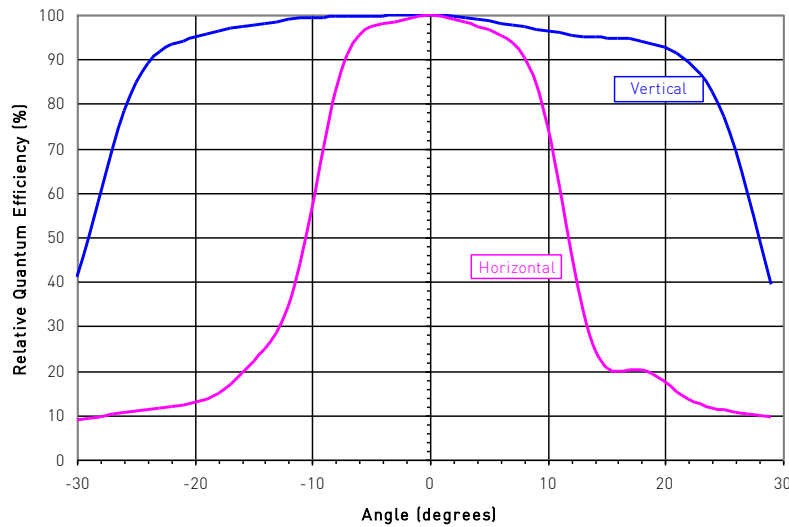

Figure 12: Monochrome with Microlens Angular Quantum Efficiency

DARK CURRENT VERSUS TEMPERATURE

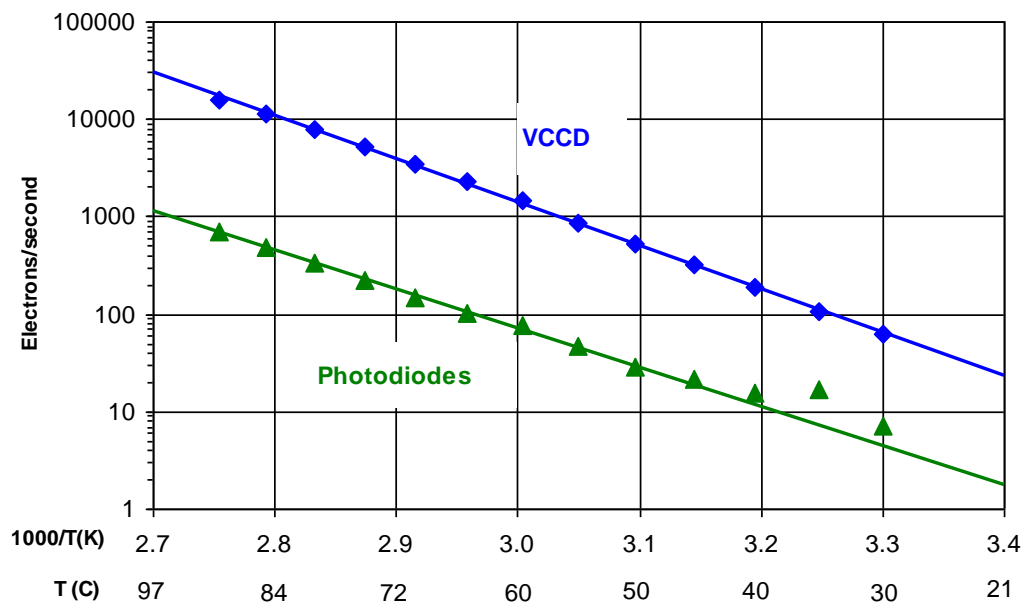

Figure 13: Dark Current versus Temperature

POWER - ESTIMATED

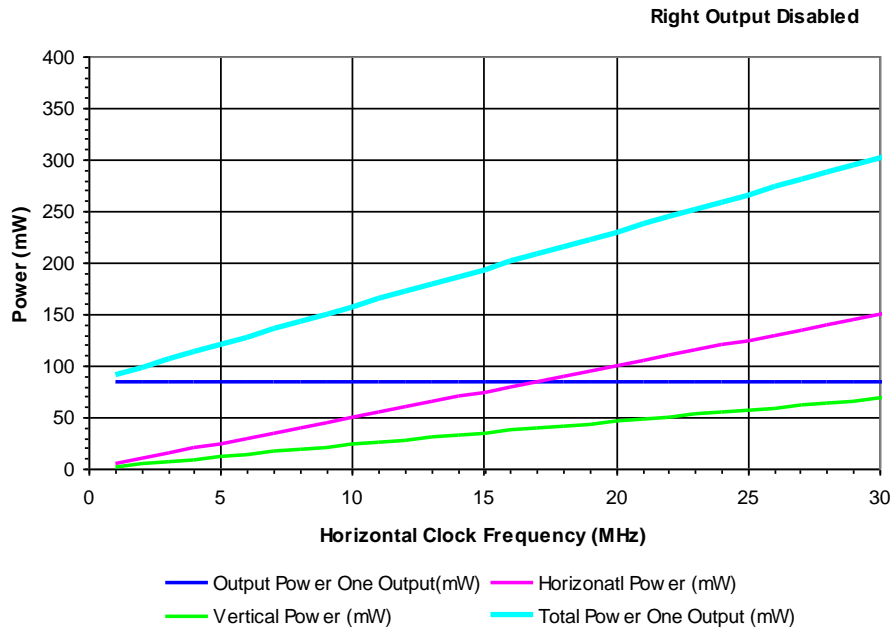

Figure 14: Power

FRAME RATES

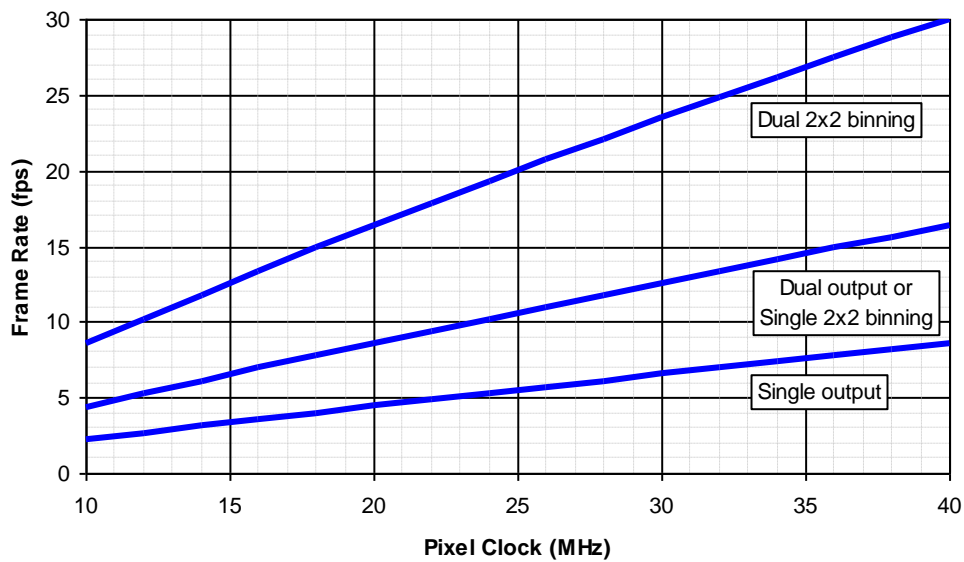

Figure 15: Frame Rates

Defect Definitions

Description	Definition	Maximum	Temperature(s) tested at (°C)	Notes
Major dark field defective pixel	Defect \geq 148 mV	40	27, 40	1
Major bright field defective pixel	Defect \geq 10%			1
Minor dark field defective pixel	Defect \geq 76 mV	400	27, 40	
Dead pixel	Defect \geq 80 %	5	27, 40	1
Saturated pixel	Defect \geq 340 mV	10	27, 40	1
Cluster defect	A group of 2 to 10 contiguous major defective pixels, but no more than 2 adjacent defects horizontally	8	27, 40	1
Column defect	A group of more than 10 contiguous major defective pixels along a single column	0	27, 40	1

Notes:

1. There will be at least two non-defective pixels separating any two major defective pixels.

DEFECT MAP

The defect map supplied with each sensor is based upon testing at an ambient (27 °C) temperature. Minor point defects are not included in the defect map. All defective pixels are reference to pixel 1,1 in the defect maps.

Test Definitions

TEST REGIONS OF INTEREST

Active Area ROI: Pixel (1, 1) to Pixel (2048, 2048)

Center 100 by 100 ROI: Pixel (974, 974) to Pixel (1073, 1073)

Only the active pixels are used for performance and defect tests.

OVERCLOCKING

The test system timing is configured such that the sensor is overclocked in both the vertical and horizontal directions. See Figure 16 for a pictorial representation of the regions.

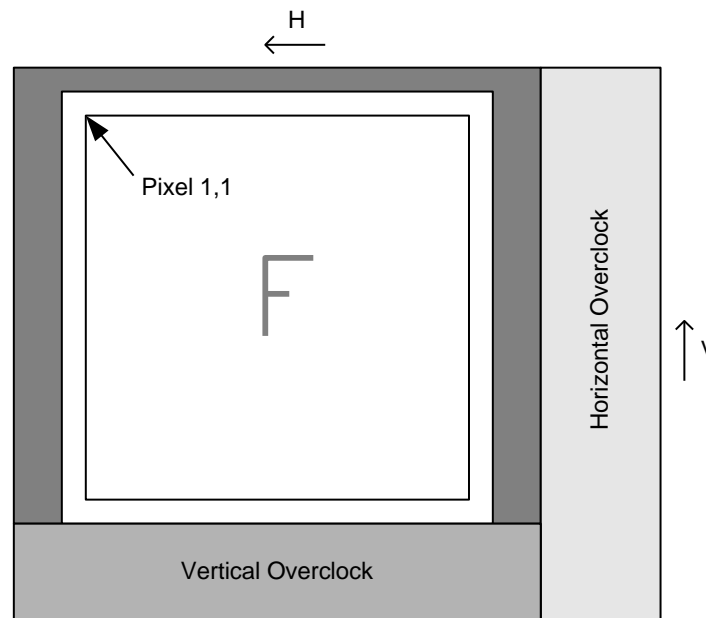

Figure 16: Overclock Regions of Interest

TESTS

Dark Field Center Non-Uniformity

This test is performed under dark field conditions. Only the center 100 by 100 pixels of the sensor are used for this test - pixel (974,974) to pixel (1073,1073).

$$\text{Dark Field Center Non-Uniformity} = \text{Standard Deviation of center 100 by 100 pixels in mV}$$

Units: mV rms

Dark Field Global Non-Uniformity

This test is performed under dark field conditions. The sensor is partitioned into 256 sub regions of interest, each of which is 128 by 128 pixels in size. The average signal level of each of the 256 sub regions of interest is calculated. The signal level of each of the sub regions of interest is calculated using the following formula:

$$\text{Signal of ROI}[i] = (\text{ROI Average in ADU} - \text{Horizontal overclock average in ADU}) * \text{mV per count.}$$

Where $i = 1$ to 256. During this calculation on the 256 sub regions of interest, the maximum and minimum signal levels are found. The dark field global non-uniformity is then calculated as the maximum signal found minus the minimum signal level found.

Units: mVpp (millivolts peak to peak)

Global Non-Uniformity

This test is performed with the imager illuminated to a level such that the output is at 70% of saturation (approximately 868 mV). Prior to this test being performed the substrate voltage has been set such that the charge capacity of the sensor is 1240 mV. Global non-uniformity is defined as

$$\text{Global Non - Uniformity} = 100 * \left(\frac{\text{Active Area Standard Deviation}}{\text{Active Area Signal}} \right) \quad \text{Units: \%rms}$$

Active Area Signal = Active Area Average – Horizontal Overclock Average

Global Peak to Peak Non-Uniformity

This test is performed with the imager illuminated to a level such that the output is at 70% of saturation (approximately 868 mV). Prior to this test being performed the substrate voltage has been set such that the charge capacity of the sensor is 1240 mV. The sensor is partitioned into 256 sub regions of interest, each of which is 128 by 128 pixels in size. The average signal level of each of the 256 sub regions of interest (ROI) is calculated. The signal level of each of the sub regions of interest is calculated using the following formula:

$$A[i] = (\text{ROI Average} - \text{Horizontal Overclock Average})$$

Where $i = 1$ to 256. During this calculation on the 256 sub regions of interest, the maximum and minimum average signal levels are found. The global peak to peak non-uniformity is then calculated as:

$$\text{Global Non - Uniformity} = 100 * \frac{A[i] \text{ Maximum Signal} - A[i] \text{ Minimum Signal}}{\text{Active Area Signal}}$$

Units: %pp. Active Area Signal = Active Area Average – Horizontal Overclock Average.

Center Non-Uniformity

This test is performed with the imager illuminated to a level such that the output is at 70% of saturation (approximately 868 mV). Prior to this test being performed the substrate voltage has been set such that the charge capacity of the sensor is 1240 mV. Defects are excluded for the calculation of this test. This test is performed on the center 100 by 100 pixels (See Test Regions of Interest) of the sensor. Center non-uniformity is defined as:

$$\text{Center ROI Non - Uniformity} = 100 * \left(\frac{\text{Center ROI Standard Deviation}}{\text{Center ROI Signal}} \right) \text{ Units: \%rms}$$

Center ROI Signal = Center ROI Average – Horizontal Overclock Average

Dark Field Defect Test

This test is performed under dark field conditions. The sensor is partitioned into 256 sub regions of interest, each of which is 128 by 128 pixels in size. In each region of interest, the median value of all pixels is found. For each region of interest, a pixel is marked defective if it is greater than or equal to the median value of that region of interest plus the defect threshold specified in “Defect Definitions” section.

Bright Field Defect Test

This test is performed with the imager illuminated to a level such that the output is at 70% of saturation (approximately 28,000 electrons). Prior to this test being performed the substrate voltage has been set such that the charge capacity of the sensor is 40,000 electrons. The average signal level of all active pixels is found. The bright and dark thresholds are set as:

Dark defect threshold = Active Area Signal * threshold

Bright defect threshold = Active Area Signal * threshold

The sensor is then partitioned into 256 sub regions of interest, each of which is 128 by 128 pixels in size. In each region of interest, the average value of all pixels is found. For each region of interest, a pixel is marked defective if it is greater than or equal to the median value of that region of interest plus the bright threshold specified or if it is less than or equal to the median value of that region of interest minus the dark threshold specified.

Example for major bright field defective pixels:

- Average value of all active pixels is found to be 868 mV (28,000 electrons).
- Dark defect threshold: $868\text{mV} * 15\% = 130.2 \text{ mV}$
- Bright defect threshold: $868\text{mV} * 15\% = 130.2 \text{ mV}$
- Region of interest #1 selected. This region of interest is pixels 1,1 to pixels 128,128.
 - Median of this region of interest is found to be 868 mV.
 - Any pixel in this region of interest that is $\geq (868+130.2 \text{ mV})$ 998.2 mV in intensity will be marked defective.
 - Any pixel in this region of interest that is $\leq (868-130.2 \text{ mV})$ 737.8 mV in intensity will be marked defective.
- All remaining 255 sub-regions of interest are analyzed for defective pixels in the same manner.

Operation

MAXIMUM RATINGS

Absolute maximum rating is defined as a level or condition that should not be exceeded at any time per the description. If the level or the condition is exceeded, the device will be degraded and may be damaged.

Description	Symbol	Minimum	Maximum	Units	Notes
Operating Temperature	T	-50	70	°C	1
Humidity	RH	5	90	%	2
Output Bias Current	I _{out}	0.0	10	mA	3
Off-chip Load	CL		10	pF	4

Notes:

- Noise performance will degrade at higher temperatures.
- T=25 °C. Excessive humidity will degrade MTTF.
- Each output. See Figure 17. Note that the current bias affects the amplifier bandwidth.
- With total output load capacitance of CL = 10pF between the outputs and AC ground.
- Absolute maximum rating is defined as a level or condition that should not be exceeded at any time per the description. If the level or the condition is exceeded, the device will be degraded and may be damaged.

MAXIMUM VOLTAGE RATINGS BETWEEN PINS

Description	Minimum	Maximum	Units	Notes
RL, RR, H1S, H2S, H1BL, H2BL, H1BR, H2BR, OGR, OGL to ESD	0	17	V	
Pin to Pin with ESD Protection	-17	17	V	1
VDDL, VDDR to GND	0	25	V	

Notes:

- Pins with ESD protection are: RL, RR, H1S, H2S, H1BL, H2BL, H1BR, H2BR, OGL, and OGR.

DC BIAS OPERATING CONDITIONS

Description	Symbol	Minimum	Nominal	Maximum	Units	Maximum DC Current (mA)	Notes
Output Gate	OG	-3.0	-2.0	-1.5	V	1 μ A	4, 5
Reset Drain	RD	11.5	12.0	12.5	V	1 μ A	4
Output Amplifier Supply	VDD	14.5	15.0	15.5	V	1 mA	3
Ground	GND	0.0	0.0	0.0	V		
Substrate	VSUB	8.0	Vab	17.0	V		1, 7
ESD Protection	ESD	-9.5	-9.0	-8.0	V		2
Output Bias Current	Iout	0.0	5.0	10.0	mA		6

Notes:

1. The operating value of the substrate voltage, Vab, will be marked on the shipping container for each device. The value Vab is set such that the photodiode charge capacity is 40,000 electrons.
2. VESD must be equal to FDL and more negative than H1L, H2L and RL during sensors operation AND during camera power turn on.
3. One output, unloaded. The maximum DC current is for one output unloaded and is shown as I_{ss} in Figure 17. This is the maximum current that the first two stages of one output amplifier will draw. This value is with V_{out} disconnected.
4. May be changed in future versions.
5. Output gate voltage level must be set to -3V for 40,000 – 80,000 electrons output in summed interlaced or binning modes.
6. One output.
7. Refer to Application Note *Using Interline CCD Image Sensors in High Intensity Visible Lighting Conditions*.

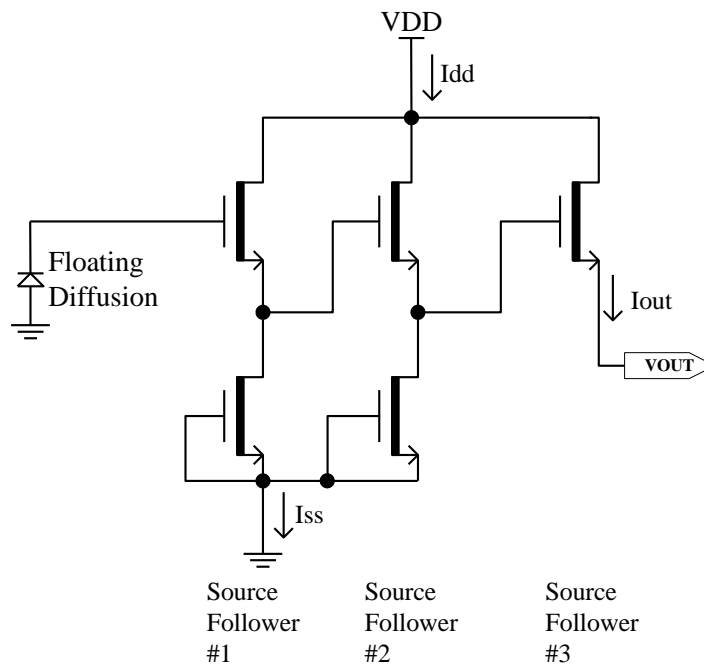

Figure 17: Output Amplifier

AC OPERATING CONDITIONS

Clock Levels

Description	Symbol	Minimum	Nominal	Maximum	Units	Notes
Vertical CCD Clock High	V2H	8.5	9.0	9.5	V	
Vertical CCD Clocks Midlevel	V1M, V2M	-0.5	0.0	0.2	V	
Vertical CCD Clocks Low	V1L, V2L	-9.5	-9.0	-8.5	V	
Horizontal CCD Clocks High	H1H, H2H	0.0	0.5	1.0	V	
Horizontal CCD Clocks Low	H1L, H2L	-5.0	-4.5	-4.0	V	
Reset Clock Amplitude	RH		5.0		V	1
Reset Clock Low	RL	-3.5	-3.0	-2.5	V	
Electronic Shutter Voltage	Vshutter	44	48	52	V	2
Fast Dump High	FDH	4	5	5	V	
Fast Dump Low	FDL	-9.5	-9	-8	V	

Notes:

1. Reset amplitude must be set to 7.0 V for 40,000 – 80,000 electrons output in summed interlaced or binning modes.
2. Refer to Application Note *Using Interline CCD Image Sensors in High Intensity Visible Lighting Conditions*.

Clock Line Capacitances

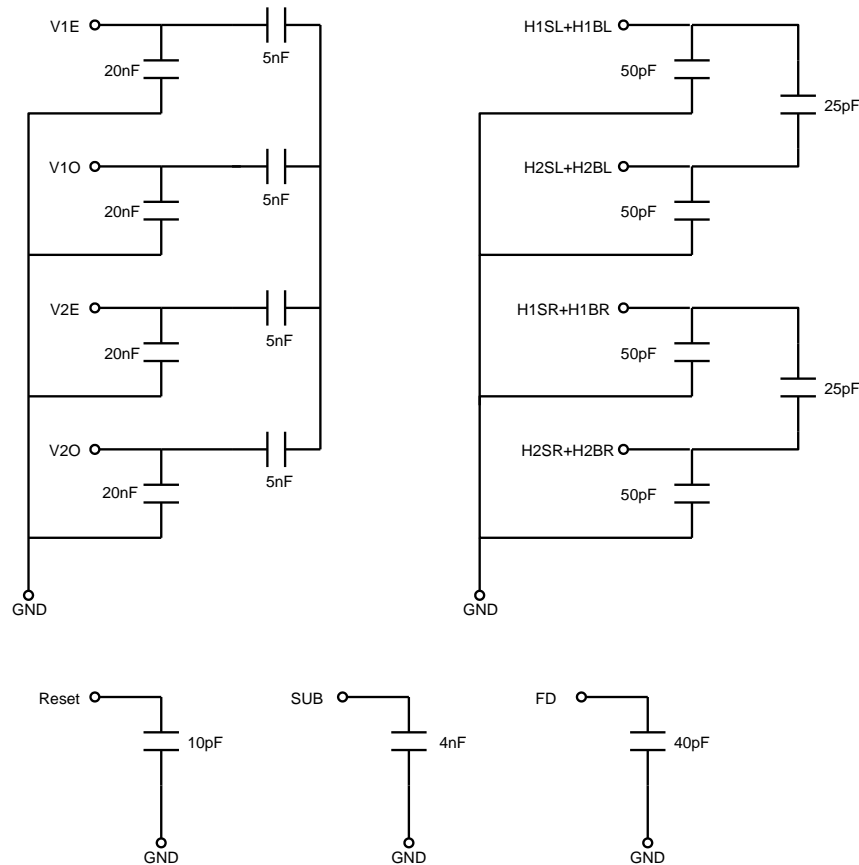

Figure 18: Clock Line Capacitances

TIMING REQUIREMENTS

Description	Symbol	Minimum	Nominal	Maximum	Units	Notes
HCCD Delay	T_{HD}	1.3	1.5	10.0	μs	
VCCD Transfer time	T_{VCCD}	1.3	1.5	20.0	μs	
Photodiode Transfer time	T_{V3rd}	3.0	5.0	15.0	μs	
VCCD Pedestal time	T_{3P}	50.0	60.0	80.0	μs	
VCCD Delay	T_{3D}	10.0	20.0	80.0	μs	
Reset Pulse time	T_R	2.5	5.0		ns	
Shutter Pulse time	T_S	3.0	4.0	10.0	μs	
Shutter Pulse delay	T_{SD}	1.0	1.5	10.0	μs	
HCCD Clock Period	T_H	25.0	50.0	200.0	ns	1
VCCD rise/fall time	T_{VR}	0.0	0.1	1.0	μs	
Fast Dump Gate delay	T_{FD}	0.5			μs	
Vertical Clock Edge Alignment	T_{VE}	0.0		100.0	ns	

Notes:

1. For operation at the minimum HCCD clock period (40MHz), the substrate voltage will need to be raised to limit the signal at the output to 20,000 electrons.

TIMING MODES

Progressive Scan

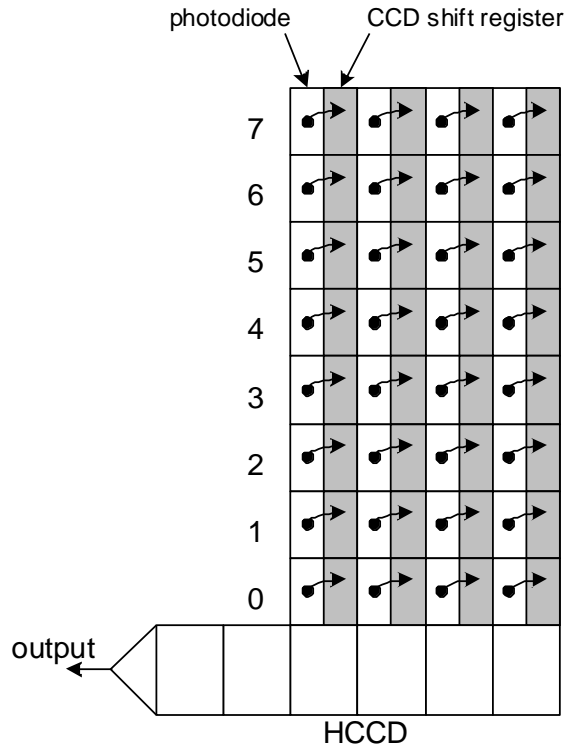

Figure 19: Progressive Scan Operation

In progressive scan read out every pixel in the image sensor is read out simultaneously. Each charge packet is transferred from the photodiode to the neighboring vertical CCD shift register simultaneously. The maximum useful signal output is limited by the photodiode charge capacity to 40,000 electrons.

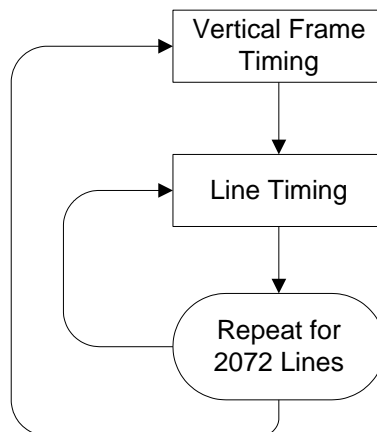

Figure 20: Progressive Scan Flow Chart

Summed Interlaced Scan

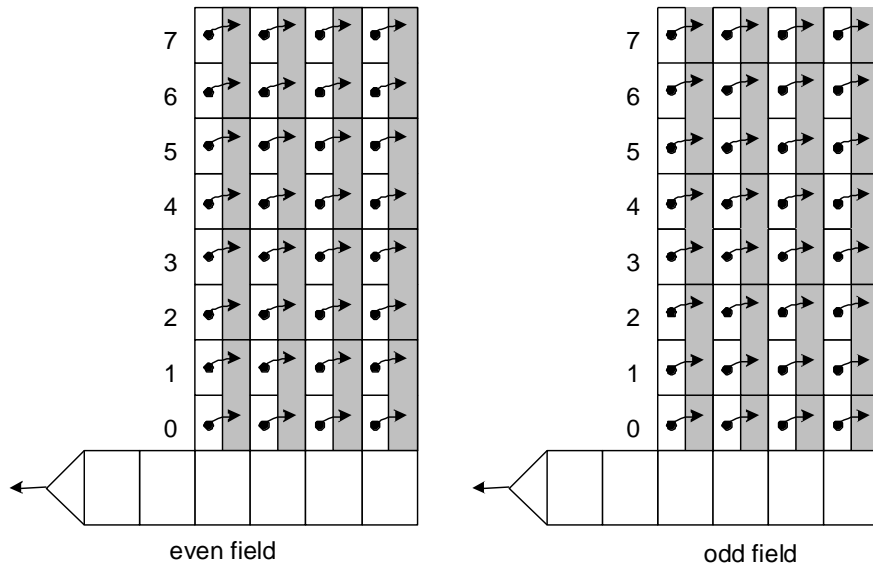

Figure 21: Summed Interlaced Scan Operation

In the summed interlaced scan read out mode, charge from two photodiodes is summed together inside the vertical CCD. The clocking of the VCCD is such that one pixel occupies the space equivalent to two pixels in the progressive scan mode. This allows the VCCD to hold twice as many electrons as in progressive scan mode. Now the maximum useful signal is limited by the charge capacity of two photodiodes at 80,000 electrons. If only one field is read out of the image sensor the apparent vertical resolution will be 1024 rows instead of the 2048 rows in progressive scan (equivalent to binning). To recover the full resolution of the image sensor two fields, even and odd, are read out. In the even field rows 0+1, 2+3, 4+5, ... are summed together. In the odd field rows 1+2, 3+4, 5+6, ... are summed together.

The modulation transfer function (MTF) of the summed interlaced scan mode is less in the vertical direction than the progressive scan. But the dynamic range is twice that of progressive scan. The vertical MTF is better than a simple binning operation. In this mode the VCCD needs to be clocked for only 1037 rows to read out each field.

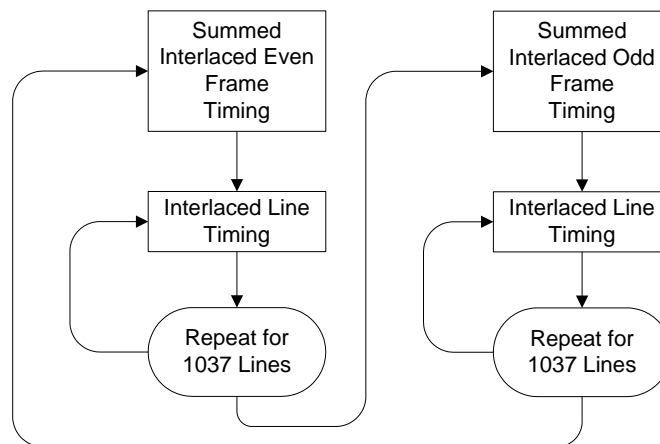

Figure 22: Summed Interlaced Scan Flow Chart

Non-Summed Interlaced Scan

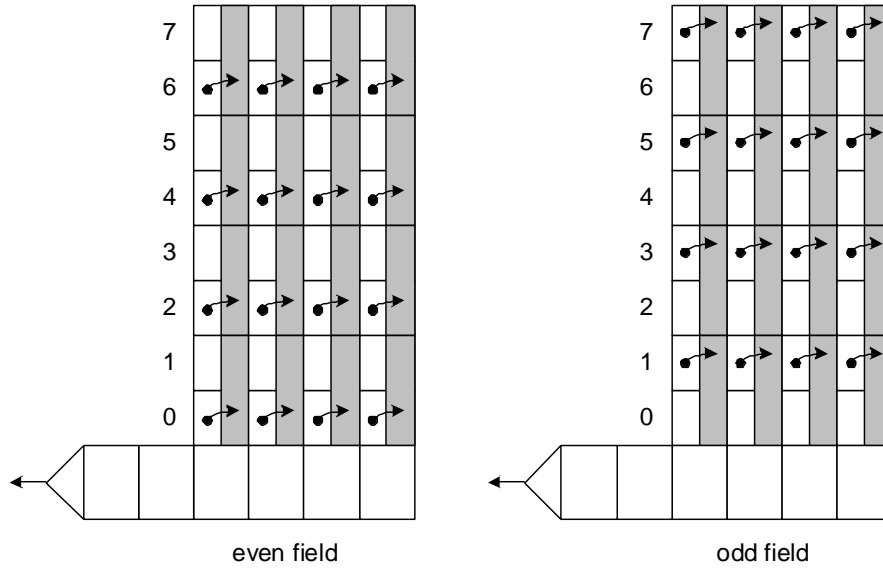

Figure 23: Non-Summed Interlaced Scan Operation

In the non-summed interlaced scan mode only half the photodiode are read out in each field. In the even field rows 0, 2, 4, ... are transferred to the VCCD. In the odd field rows 1, 3, 5, ... are transferred to the VCCD. When the charge packet is transferred from a photodiode it occupies the equivalent of two rows in progressive scan mode. This allows the VCCD to hold twice as much charge a progressive scan mode. However, since only one photodiode for each row is transferred to the VCCD the maximum usable signal is still only 40,000 electrons. The large extra capacity of the VCCD causes the anti-blooming protection to be increased dramatically compared to the progressive scan. The vertical MTF is the same between the non-summed interlaced scan and progressive scan. There will be motion related artifacts in the images read out in the interlaced modes because the two fields are acquired at different times.

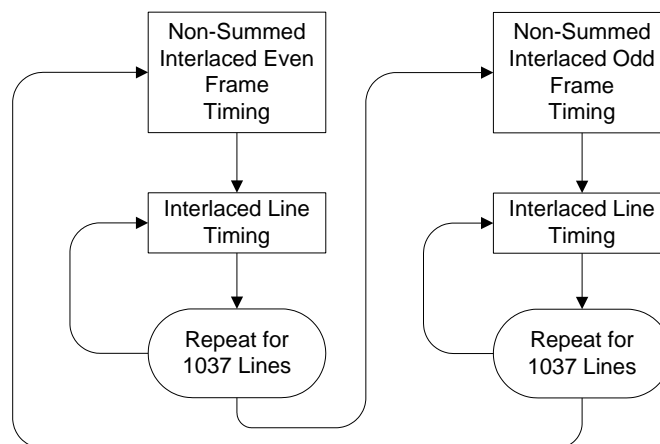

Figure 24: Non-Summed Interlaced Scan Flow Chart

FRAME TIMING

Frame Timing without Binning – Progressive Scan

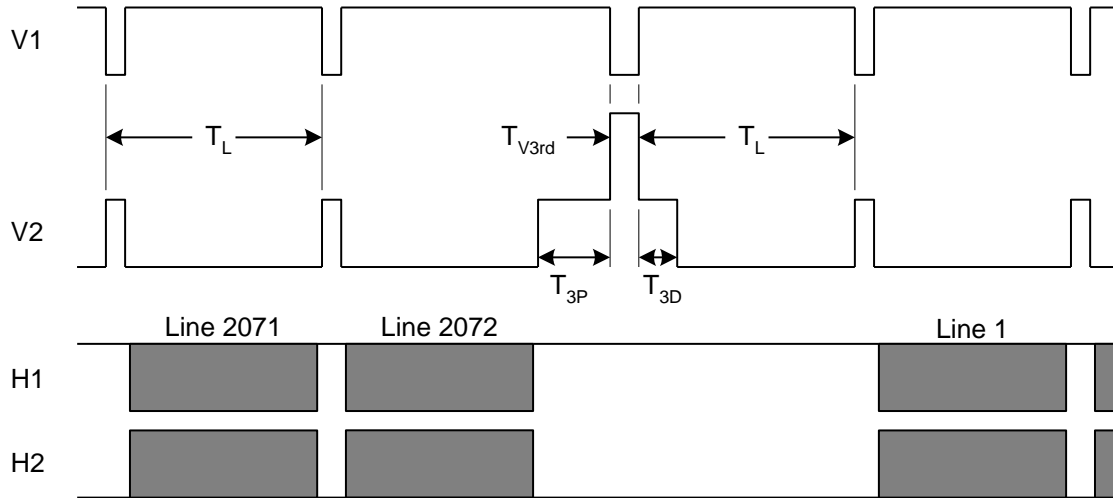

Figure 25: Framing Timing without Binning

Frame Timing for Vertical Binning by 2 – Progressive Scan

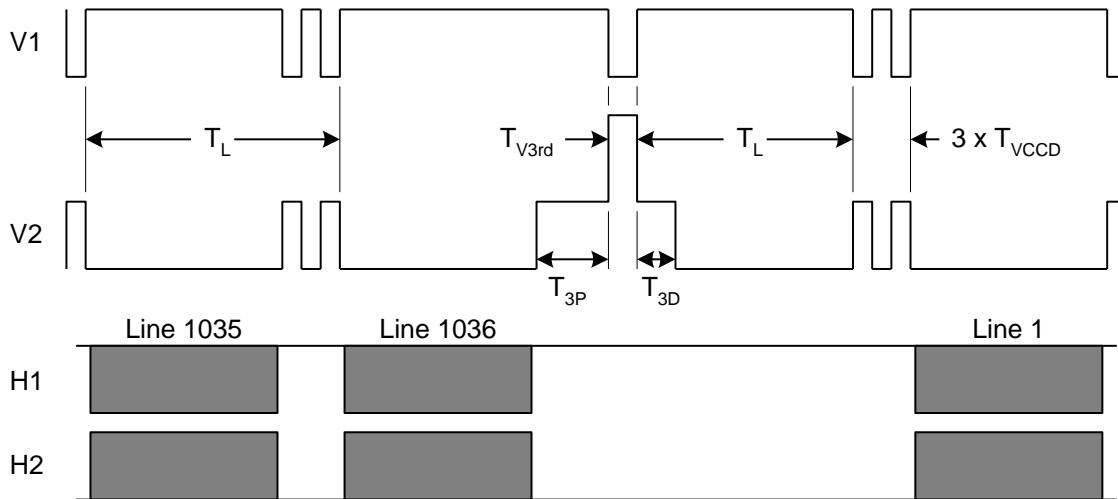

Figure 26: Frame Timing for Vertical Binning by 2

Frame Timing Non-Summed Interlaced Scan (Even)

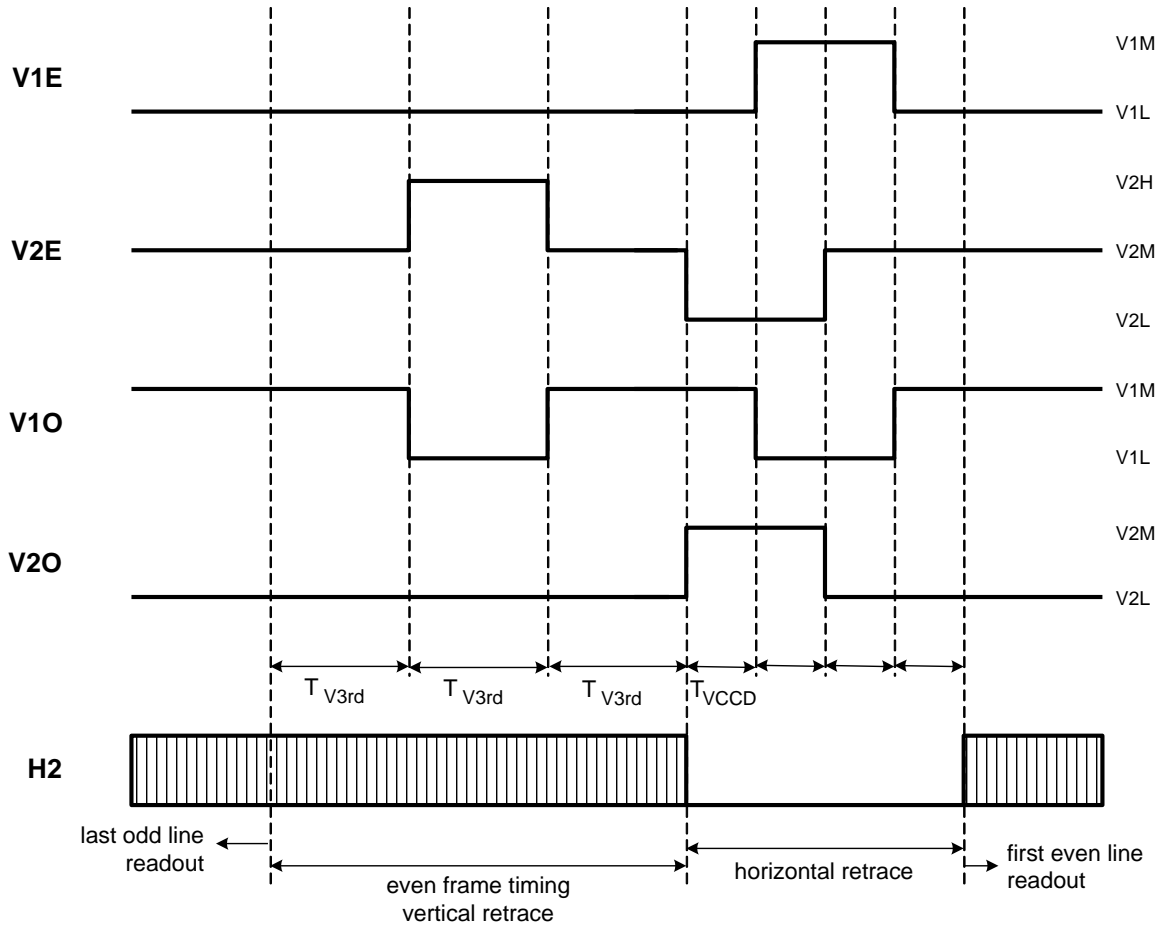

Figure 27: Non-Summed Interlaced Scan Even Frame Timing

Frame Timing Non-Summed Interlaced Scan (Odd)

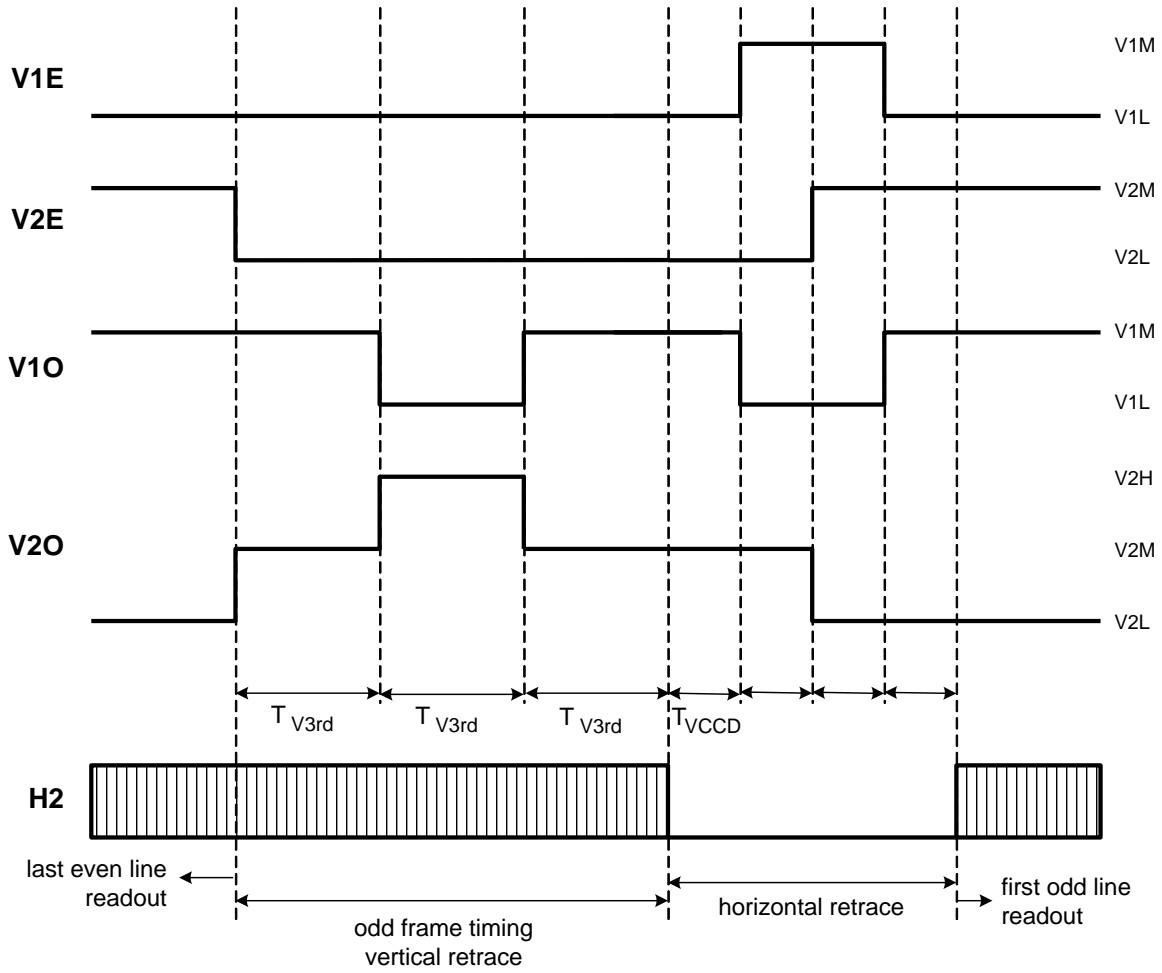

Figure 28: Non-Summed Interlaced Scan Odd Frame Timing

Frame Timing Summed Interlaced Scan (Even)

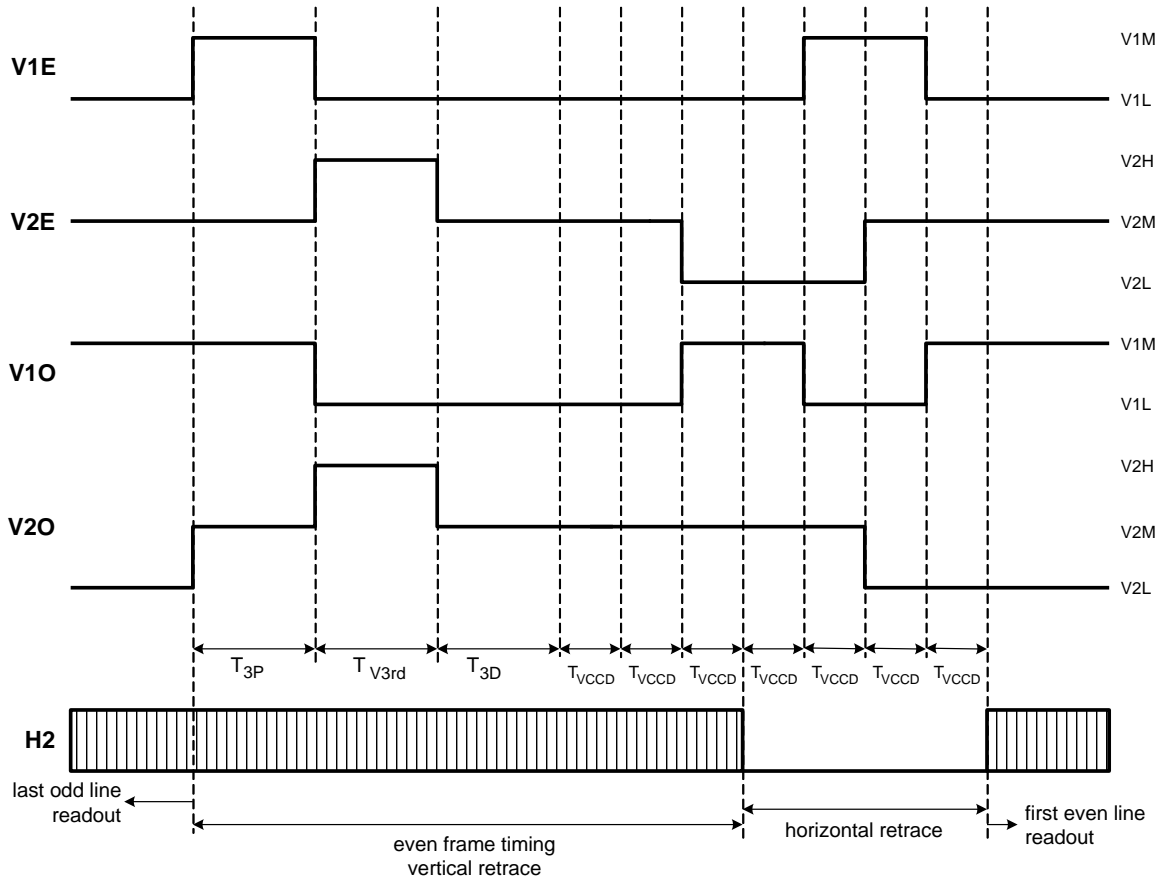

Figure 29: Summed Interlaced Scan Even Frame Timing

Frame Timing Summed Interlaced Scan (Odd)

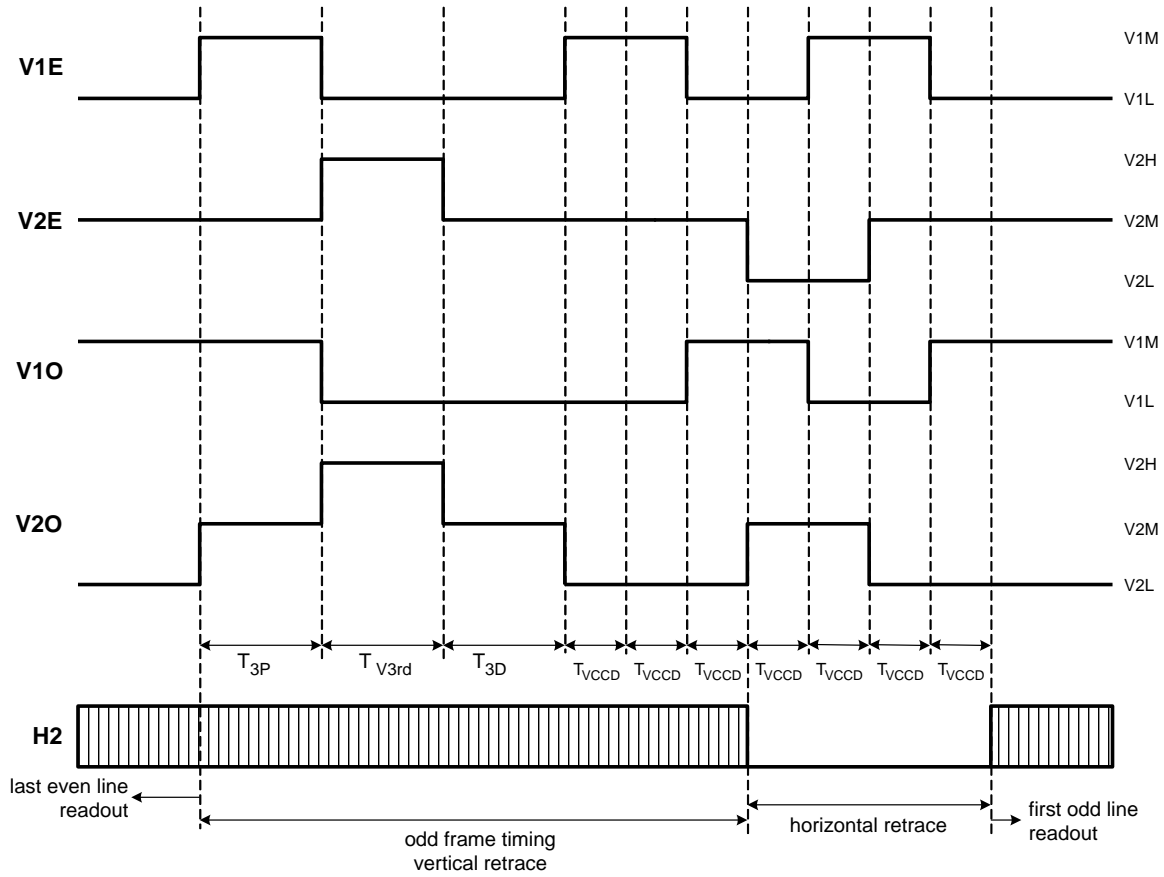

Figure 30: Summed Interlaced Scan Odd Frame Timing

Frame Timing Edge Alignment

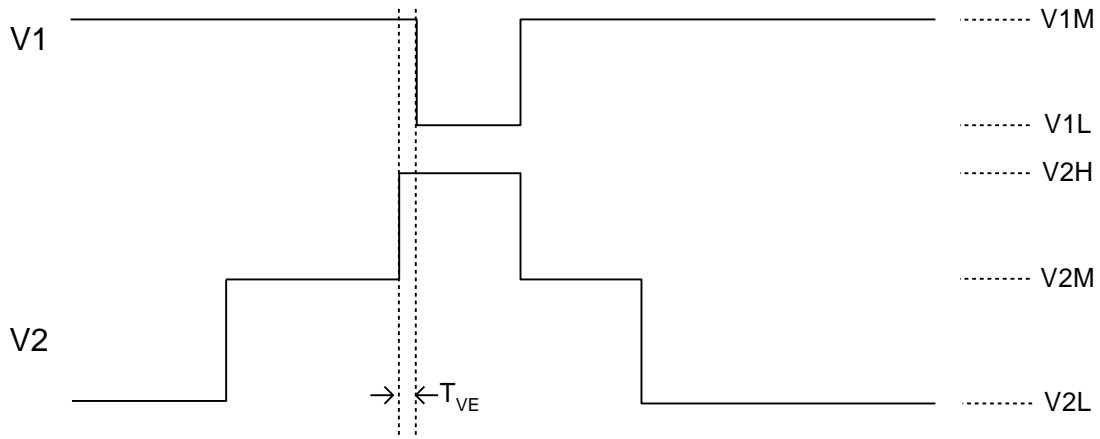

Figure 31: Frame Timing Edge Alignment

LINE TIMING

Line Timing Single Output – Progressive Scan

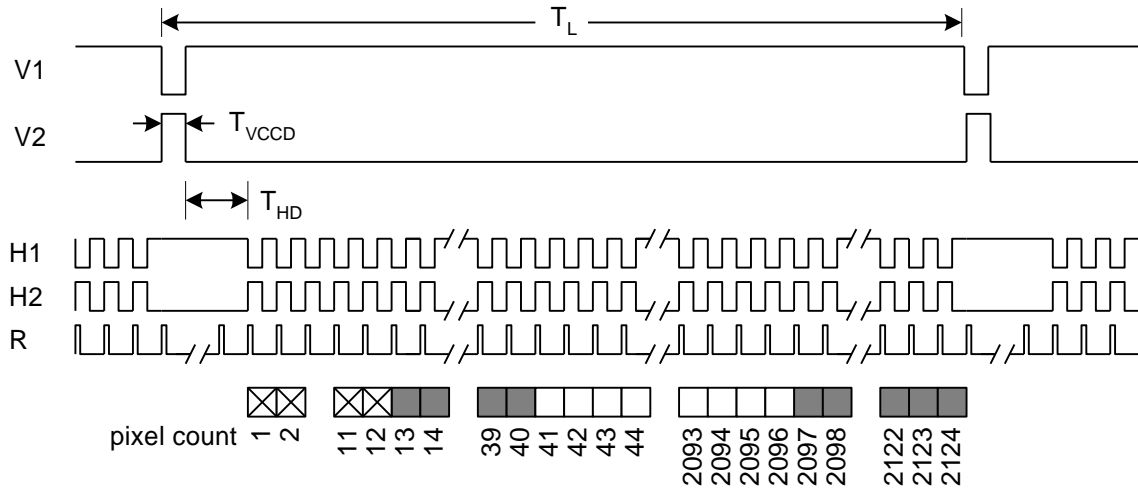

Figure 32: Line Timing Single Output

Line Timing Dual Output – Progressive Scan

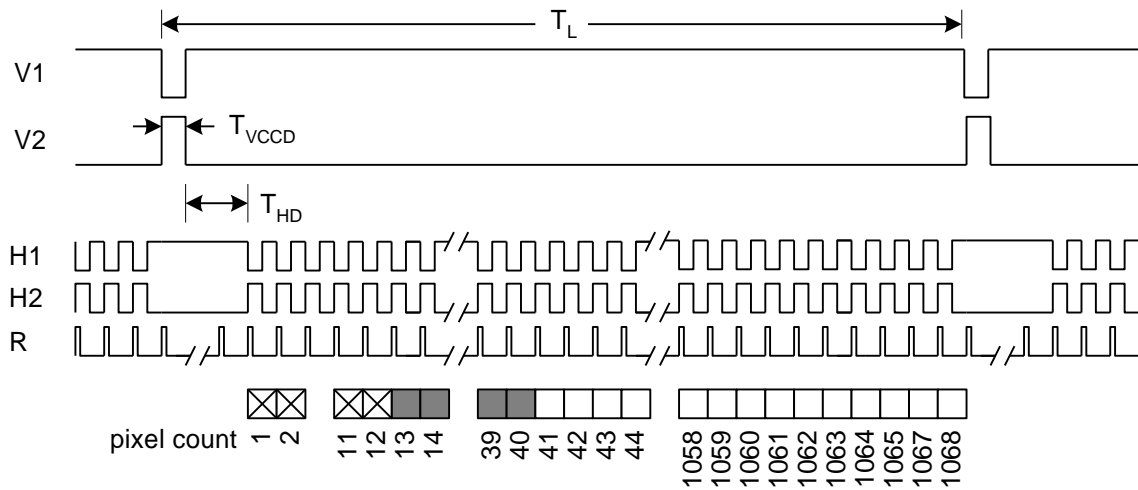

Figure 33: Line Timing Dual Output

Line Timing Vertical Binning by 2 – Progressive Scan

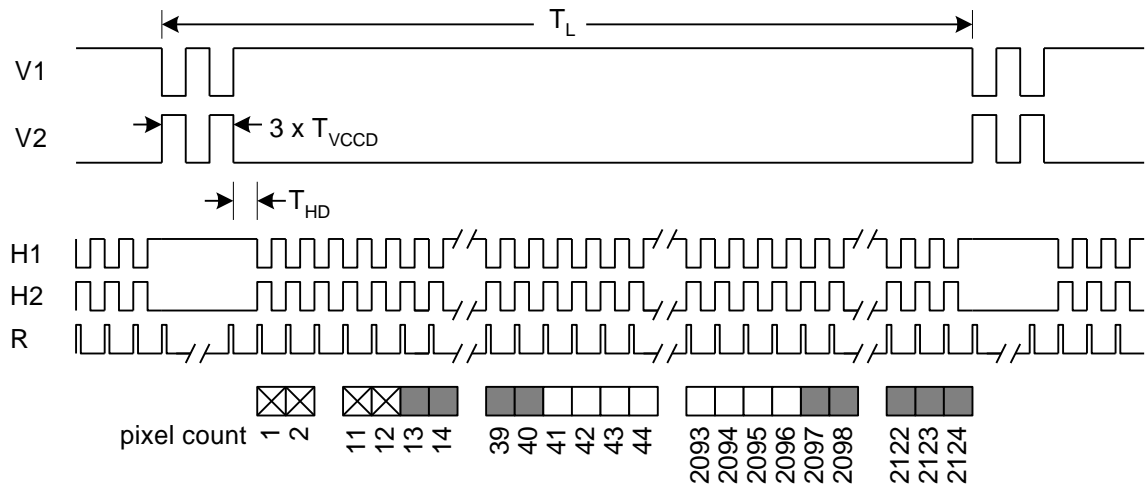

Figure 34: Line Timing Vertical Binning by 2

Line Timing Detail – Progressive Scan

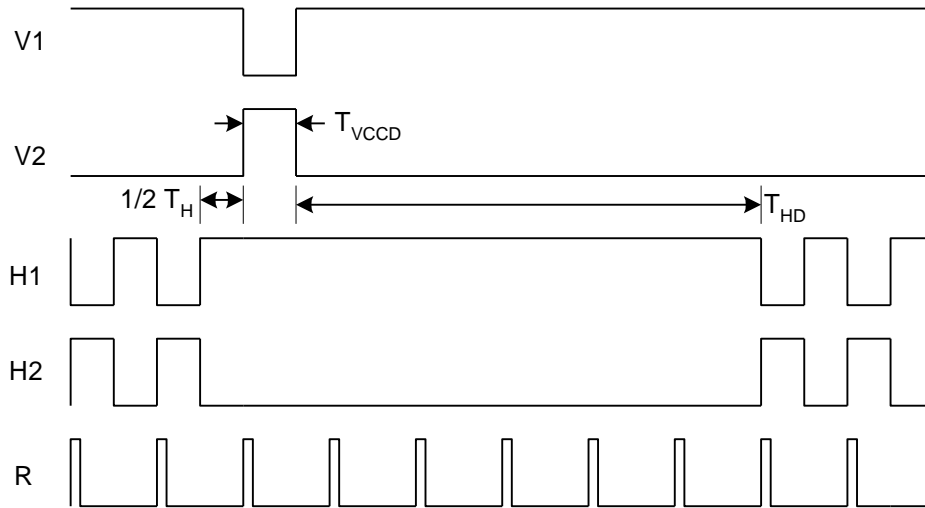

Figure 35: Line Timing Detail

Line Timing Binning by 2 Detail – Progressive Scan

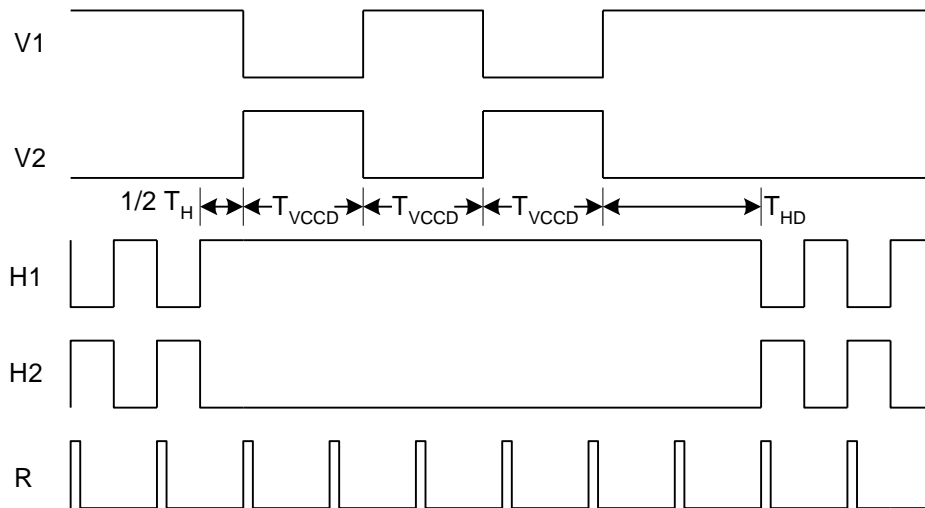

Figure 36: Line Timing by 2 Detail

Line Timing Interlaced Modes

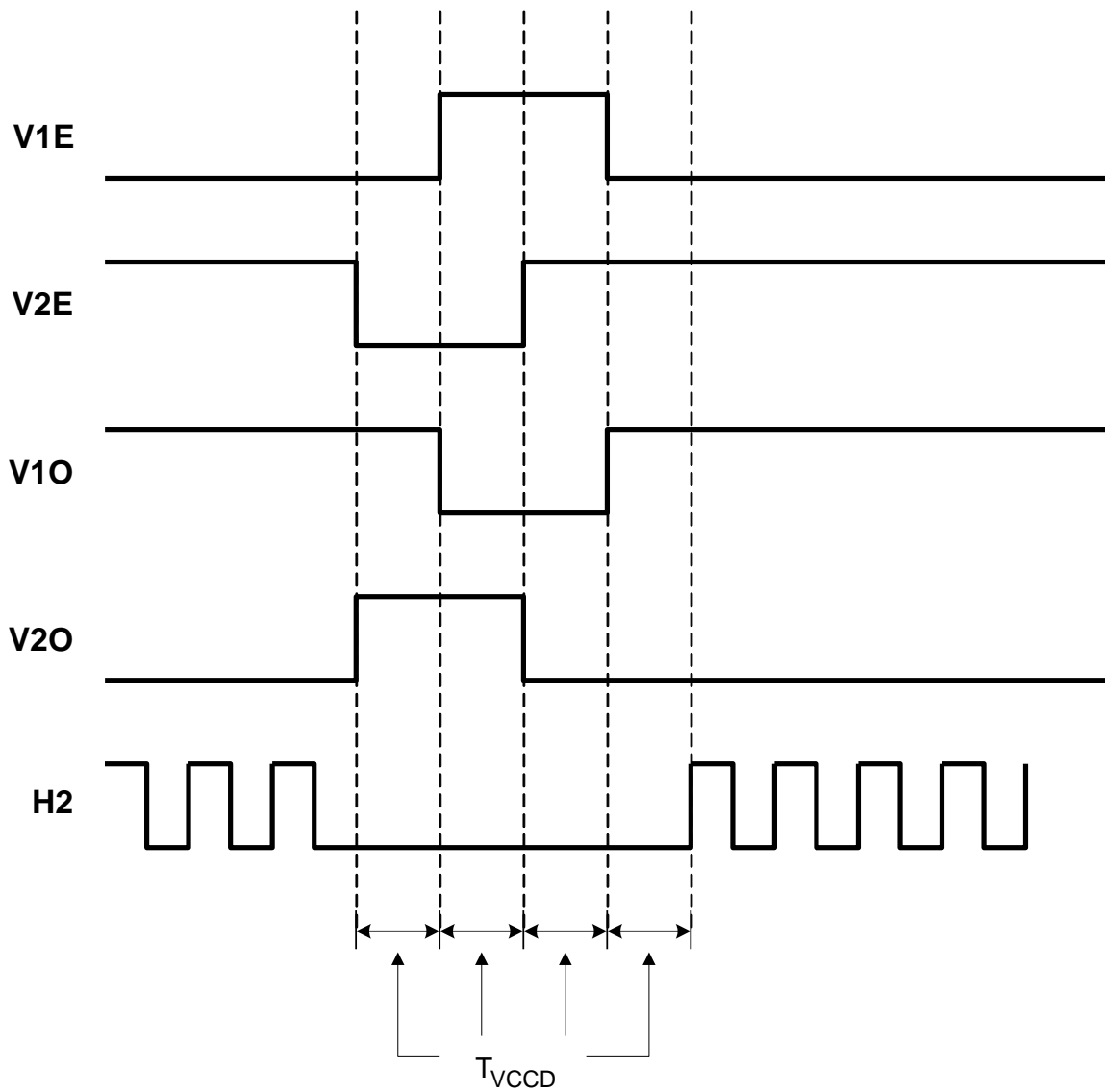

Figure 37: Line Timing Interlaced Modes

Line Timing Edge Alignment

Applies to all modes.

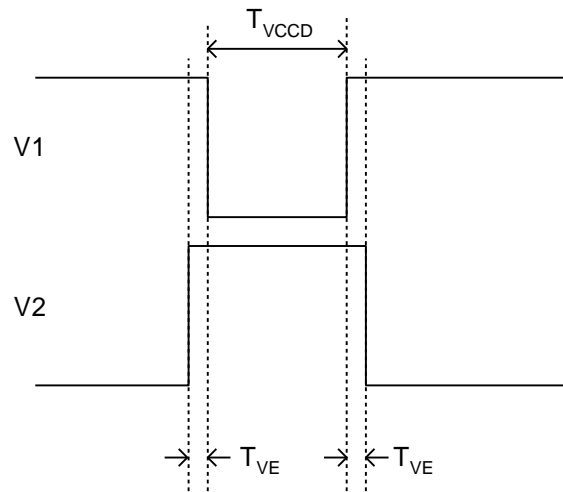

Figure 38: Line Timing Edge Alignment

PIXEL TIMING

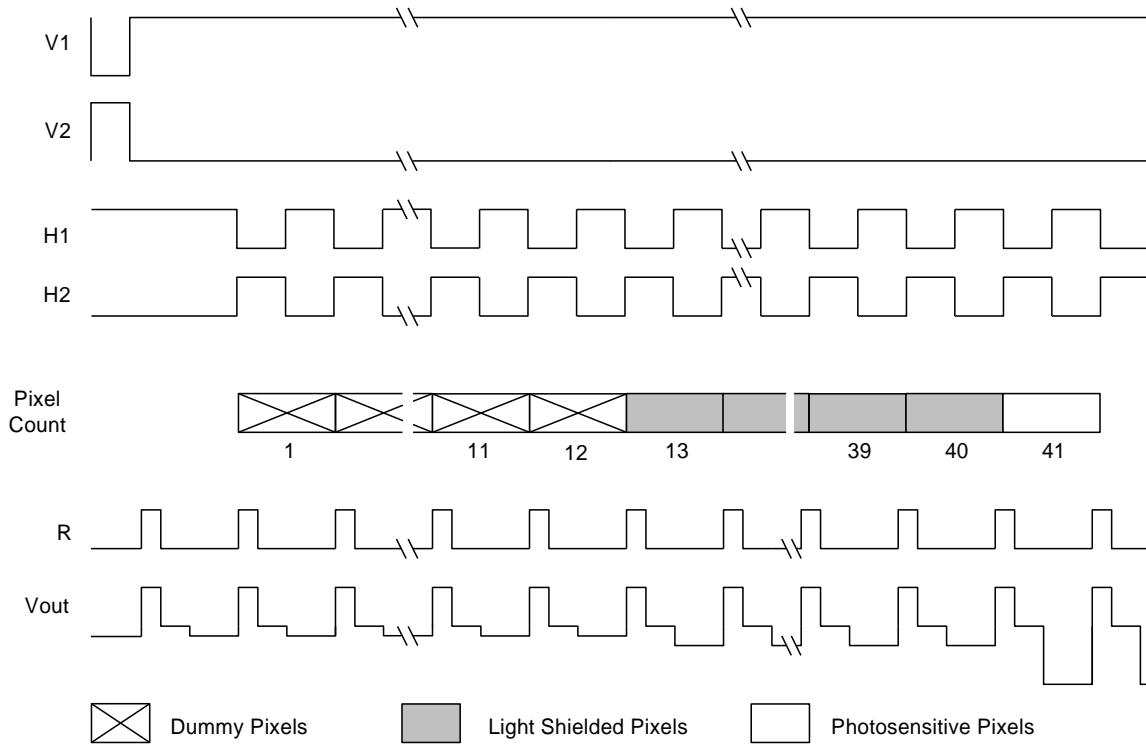

Figure 39: Pixel Timing

Pixel Timing Detail

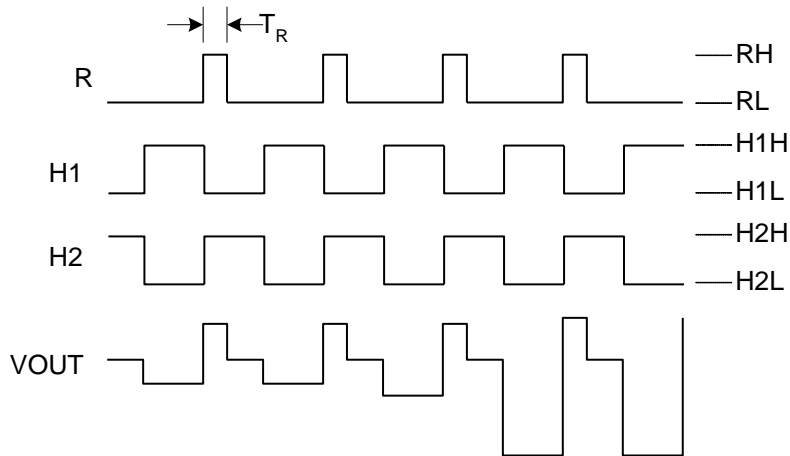

Figure 40: Pixel Timing Detail

FAST LINE DUMP TIMING

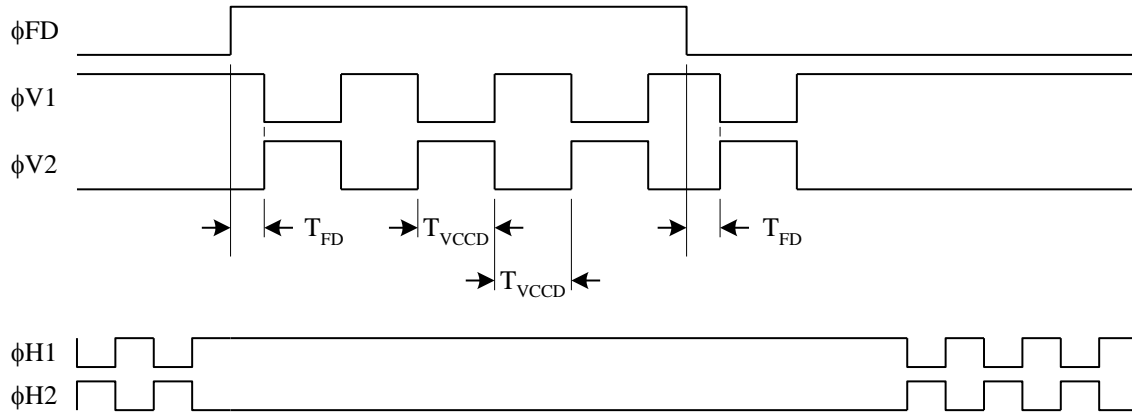

Figure 41: Fast Line Dump Timing

ELECTRONIC SHUTTER

Electronic Shutter Line Timing

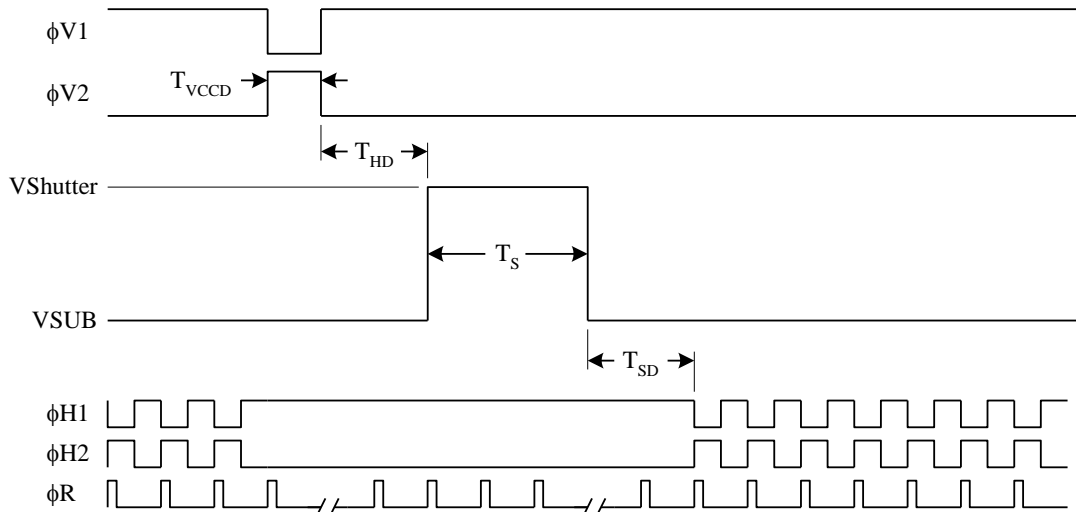

Figure 42: Electronic Shutter Line Timing

Electronic Shutter – Integration Time Definition

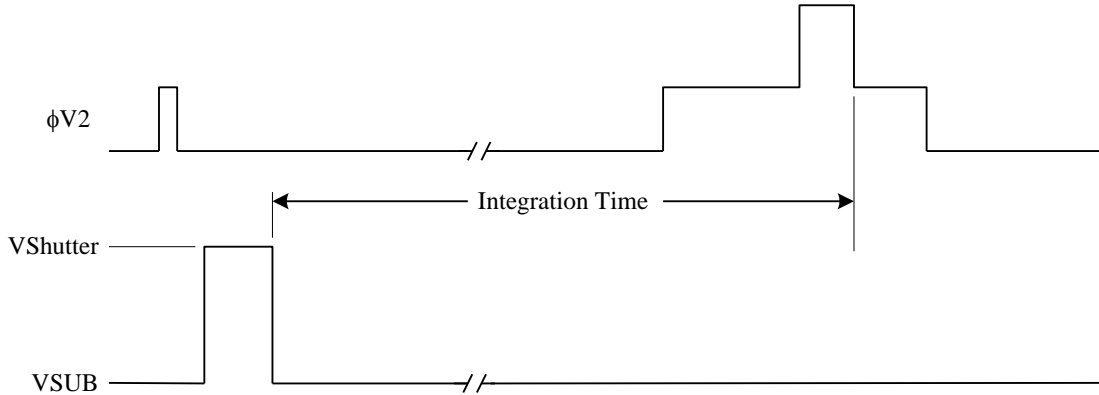
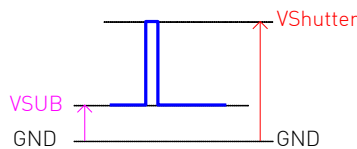

Figure 43: Integration Time Definition

Electronic Shutter – DC and AC Bias Definition

The figure below shows the DC bias (V_{SUB}) and AC clock (V_{ES}) applied to the SUB pin. Both the DC bias and AC clock are referenced to ground.



Electronic Shutter Description

The voltage on the substrate (SUB) determines the charge capacity of the photodiodes. When SUB is 8 V the photodiodes will be at their maximum charge capacity. Increasing V_{SUB} above 8 V decreases the charge capacity of the photodiodes until 48 V when the photodiodes have a charge capacity of zero electrons. Therefore, a short pulse on SUB, with a peak amplitude greater than 48 V, empties all photodiodes and provides the electronic shuttering action.

It may appear the optimal substrate voltage setting is 8 volts to obtain the maximum charge capacity and dynamic range. While setting V_{SUB} to 8 volts will provide the maximum dynamic range, it will also provide the minimum antiblooming protection.

The KAI-04022 VCCD has a charge capacity of 60,000 electrons (60 ke^-). If the SUB voltage is set such that the photodiode holds more than 60 ke^- , then when the charge is transferred from a full photodiode to VCCD, the VCCD will overflow. This overflow condition manifests itself in the image by making bright spots appear elongated in the vertical direction. The size increase of a bright spot is called blooming when the spot doubles in size. The blooming can be eliminated by increasing the voltage on SUB to lower the charge capacity of the photodiode. This ensures the VCCD charge capacity is greater than the photodiode capacity. There are cases where an extremely bright spot will still cause blooming in the VCCD. Normally, when the photodiode is full, any additional electrons generated by photons will spill out of the photodiode. The excess electrons are drained harmlessly out to the substrate. There is a maximum rate at which the electrons can be drained to the substrate. If that maximum rate is exceeded, (for example, by a very bright light source) then it is possible for the total amount of charge in the photodiode to exceed the VCCD capacity. This results in blooming. The amount of antiblooming protection also decreases when the integration time is decreased. There is a compromise between photodiode dynamic range (controlled by V_{SUB}) and the amount of antiblooming protection. A low V_{SUB} voltage provides the maximum dynamic range and minimum (or no) antiblooming protection. A high V_{SUB} voltage provides lower dynamic range and maximum antiblooming protection. The optimal setting of V_{SUB} is written on the container in which each KAI-04022 is shipped. The given V_{SUB} voltage for each sensor is selected to provide antiblooming protection for bright spots at least 100 times saturation, while maintaining at least 40ke^- of dynamic range.

The electronic shutter provides a method of precisely controlling the image exposure time without any mechanical components. If an integration time of T_{INT} is desired, then the substrate voltage of the sensor is pulsed to at least 40 volts T_{INT} seconds before the photodiode to VCCD transfer pulse on V2. Use of the electronic shutter does not have to wait until the previously acquired image has been completely read out of the VCCD.

LARGE SIGNAL OUTPUT

When the image sensor is operated in the binned or summed interlaced modes there will be more than 20,000 electrons in the output signal. The image sensor is designed with a 31 $\mu\text{V}/\text{e}$ charge to voltage conversion on the output. This means a full signal of 20,000 electrons will produce a 640 mV change on the output amplifier. The output amplifier was designed to handle an output swing of 640 mV at a pixel rate of 40 MHz. If 40,000 electron charge packets are generated in the binned or summed interlaced modes then the output amplifier output will have to swing 1280 mV. The output amplifier does not have enough bandwidth (slew rate) to handle 1280 mV at 40 MHz. Hence, the pixel rate will have to be reduced to 20 MHz if the full dynamic range of 40,000 electrons is desired.

The charge handling capacity of the output amplifier is also set by the reset clock voltage levels. The reset clock driver circuit is very simple if an amplitude of 5V is used. But the 5V amplitude restricts the output amplifier charge capacity to 20,000 electrons. If the full dynamic range of 40,000 electrons is desired then the reset clock amplitude will have to be increased to 7 V.

If you only want a maximum signal of 20,000 electrons in binned or summed interlaced modes, then a 40 MHz pixel rate with a 5V reset clock may be used. The output of the amplifier will be unpredictable above 20,000 electrons so be sure to set the maximum input signal level of your analog to digital converter to the equivalent of 20,000 electrons (640mV).

Storage and Handling

STORAGE CONDITIONS

Description	Symbol	Minimum	Maximum	Units	Notes
Storage Temperature	T _{ST}	-55	80	°C	1
Humidity	RH	5	90	%	2

Notes:

1. Long-term exposure toward the maximum temperature will accelerate color filter degradation.
2. T=25 °C. Excessive humidity will degrade MTTF.

ESD

1. This device contains limited protection against Electrostatic Discharge (ESD). ESD events may cause irreparable damage to a CCD image sensor either immediately or well after the ESD event occurred. Failure to protect the sensor from electrostatic discharge may affect device performance and reliability.
2. Devices should be handled in accordance with strict ESD procedures for Class 0 (<250V per JESD22 Human Body Model test), or Class A (<200V JESD22 Machine Model test) devices. Devices are shipped in static-safe containers and should only be handled at static-safe workstations.
3. See Application Note *Image Sensor Handling Best Practices* for proper handling and grounding procedures. This application note also contains workplace recommendations to minimize electrostatic discharge.
4. Store devices in containers made of electro-conductive materials.

COVER GLASS CARE AND CLEANLINESS

1. The cover glass is highly susceptible to particles and other contamination. Perform all assembly operations in a clean environment.
2. Touching the cover glass must be avoided.
3. Improper cleaning of the cover glass may damage these devices. Refer to Application Note *Image Sensor Handling Best Practices*.

ENVIRONMENTAL EXPOSURE

1. Extremely bright light can potentially harm CCD image sensors. Do not expose to strong sunlight for long periods of time, as the color filters and/or microlenses may become discolored. In addition, long time exposures to a static high contrast scene should be avoided. Localized changes in response may occur from color filter/microlens aging. For Interline devices, refer to Application Note *Using Interline CCD Image Sensors in High Intensity Visible lighting Conditions*.
2. Exposure to temperatures exceeding maximum specified levels should be avoided for storage and operation, as device performance and reliability may be affected.
3. Avoid sudden temperature changes.
4. Exposure to excessive humidity may affect device characteristics and may alter device performance and reliability, and therefore should be avoided.
5. Avoid storage of the product in the presence of dust or corrosive agents or gases, as deterioration of lead solderability may occur. It is advised that the solderability of the device leads be assessed after an extended period of storage, over one year.

SOLDERING RECOMMENDATIONS

1. The soldering iron tip temperature is not to exceed 370 °C. Higher temperatures may alter device performance and reliability.
2. Flow soldering method is not recommended. Solder dipping can cause damage to the glass and harm the imaging capability of the device. Recommended method is by partial heating using a grounded 30 W soldering iron. Heat each pin for less than 2 seconds duration.

Mechanical Drawings

COMPLETED ASSEMBLY

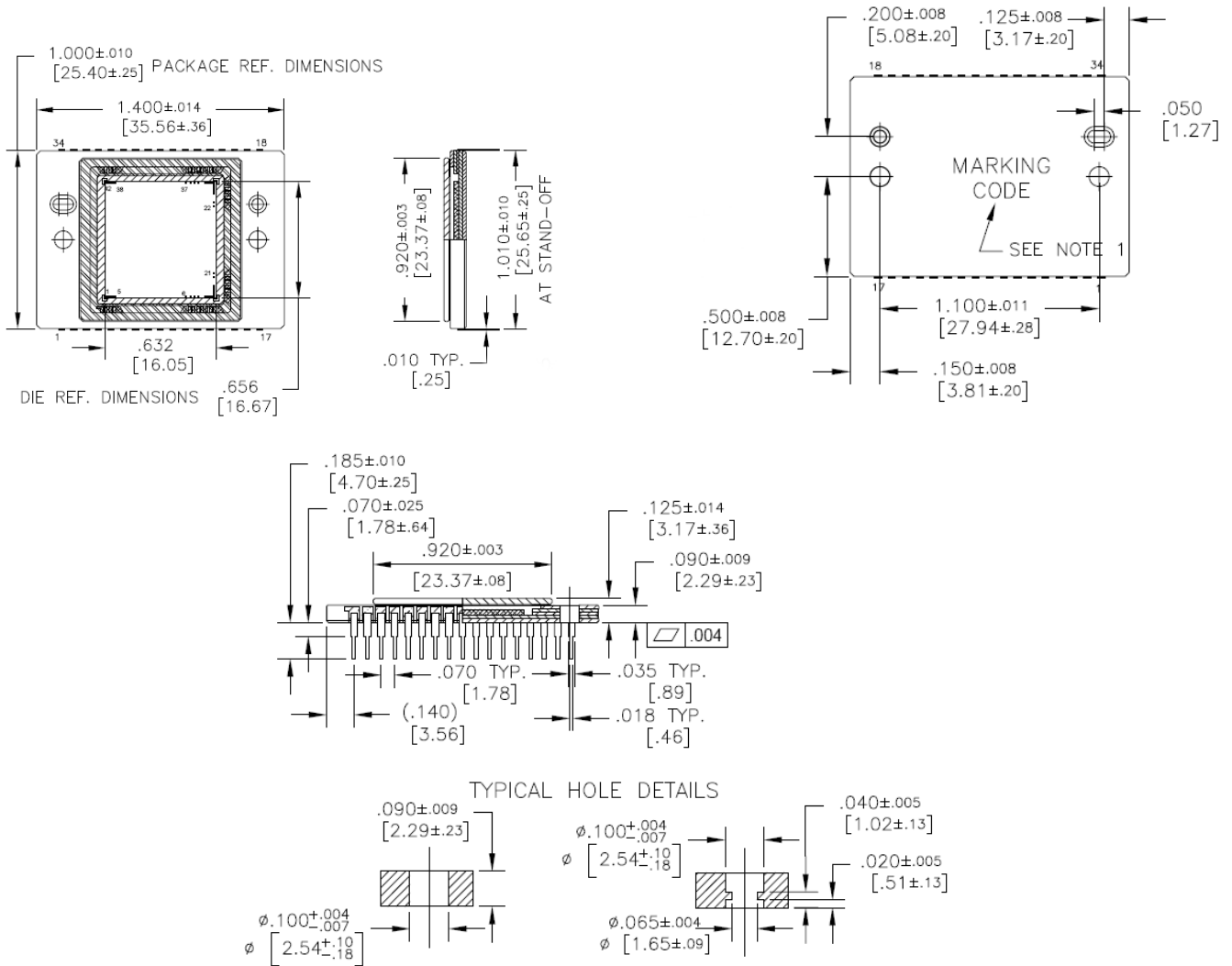
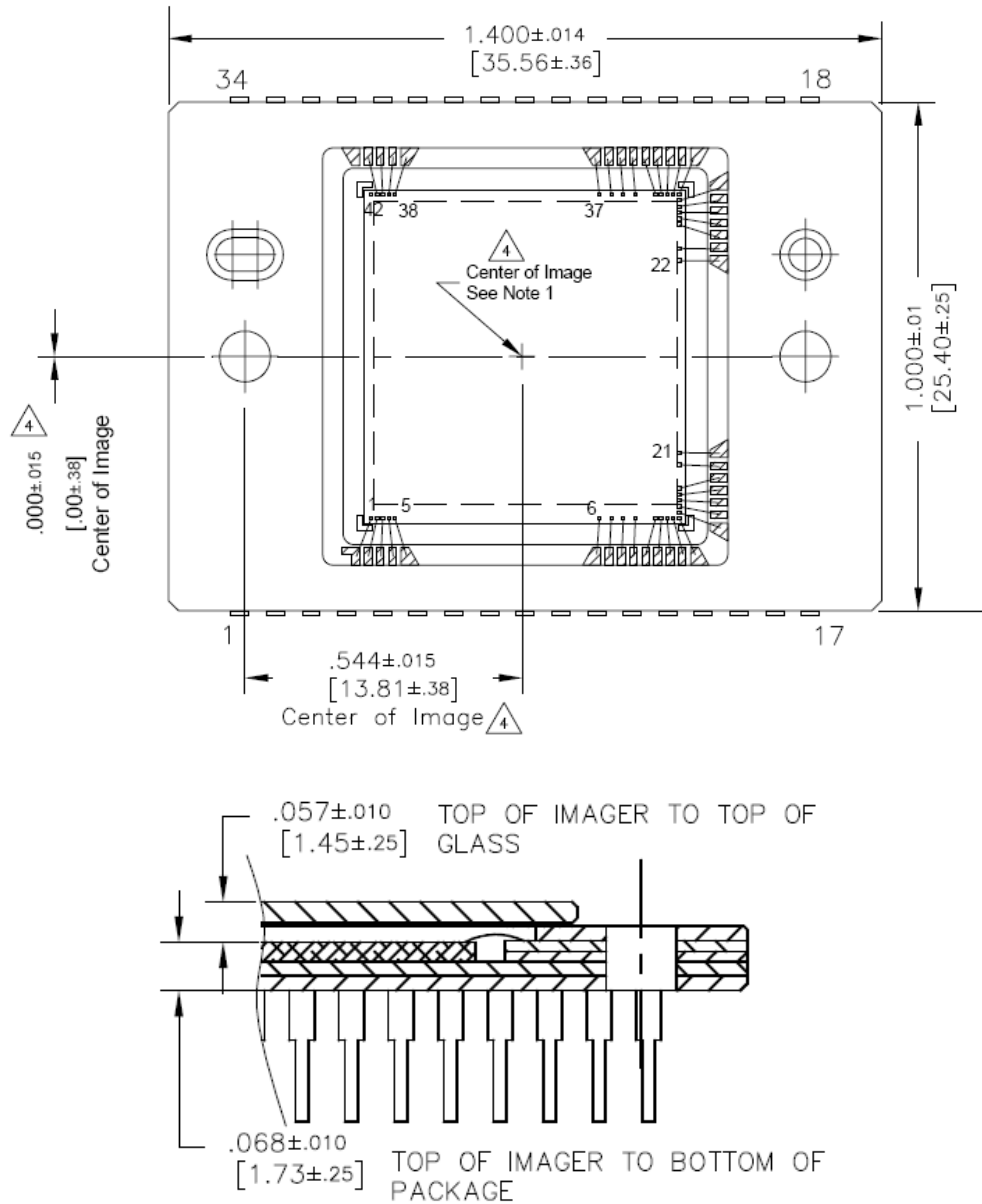

Figure 44: Completed Assembly

Notes:

1. See Ordering Information for Marking Code
2. The cover glass is manually placed and aligned.

DIE TO PACKAGE ALIGNMENT



- NOTES:
- ④ 1. CENTER OF IMAGE IS OFFSET FROM CENTER OF PACKAGE BY COORDINATES $(-.157, 0.000)$ mm NOMINAL.
 2. DIE IS ALIGNED IN WITHIN ± 1 DEGREES OF ANY PACKAGE CAVITY EDGE.

Figure 45: Die to Package Alignment

GLASS

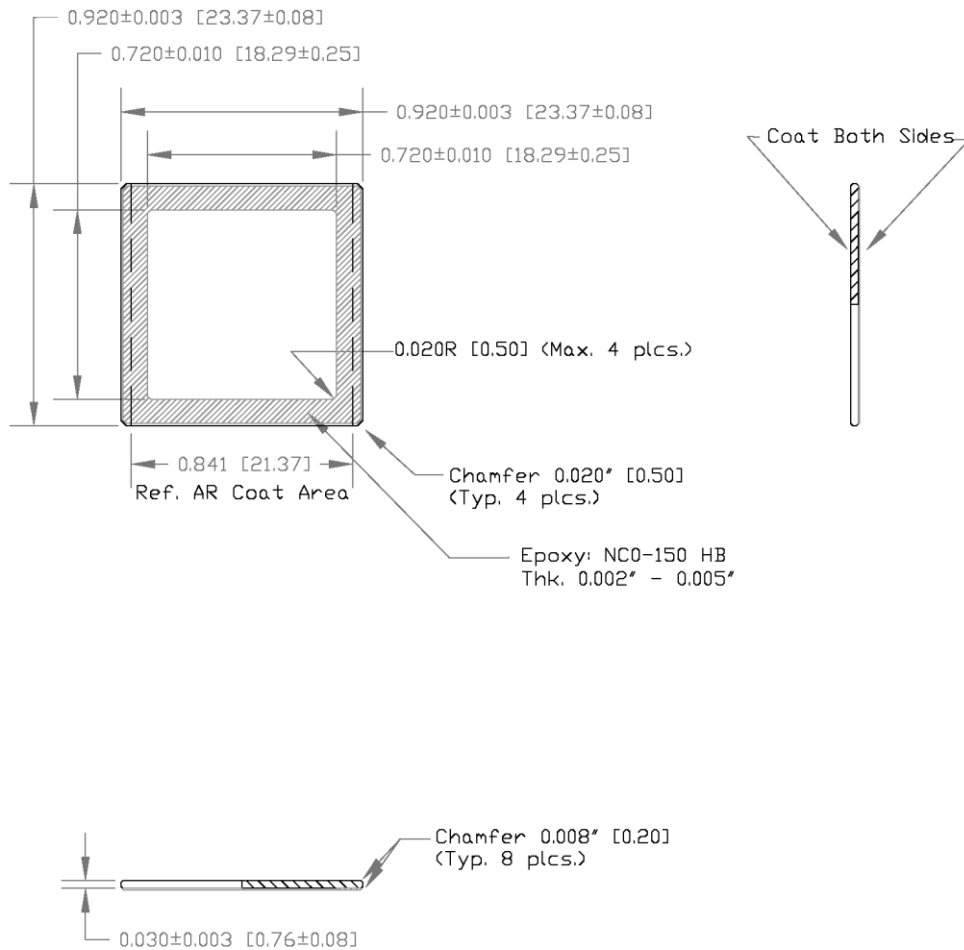

Figure 46: Glass Drawing

Notes:

1. Multi-Layer Anti-Reflective Coating on 2 sides:
 - a. Double Sided Reflectance:
 - b. Range (nm)
 - i. 420 – 435 nm < 2.0%
 - ii. 435 – 630 nm < 0.8%
 - iii. 630 – 680 nm < 2.0%
2. Dust, Scratch specification – 10 microns max.
3. Substrate – Schott D263T eco or equivalent
4. Epoxy: NCO-150HB
 - a. Thickness: $0.002'' - 0.005''$
5. Dimensions
 - a. Units: INCH [MM]
6. Tolerance, unless otherwise specified
 - a. Ceramic: $\pm 1\%$ no less than $0.004''$
 - b. L/F: $\pm 1\%$ no more than $0.004''$

GLASS TRANSMISSION

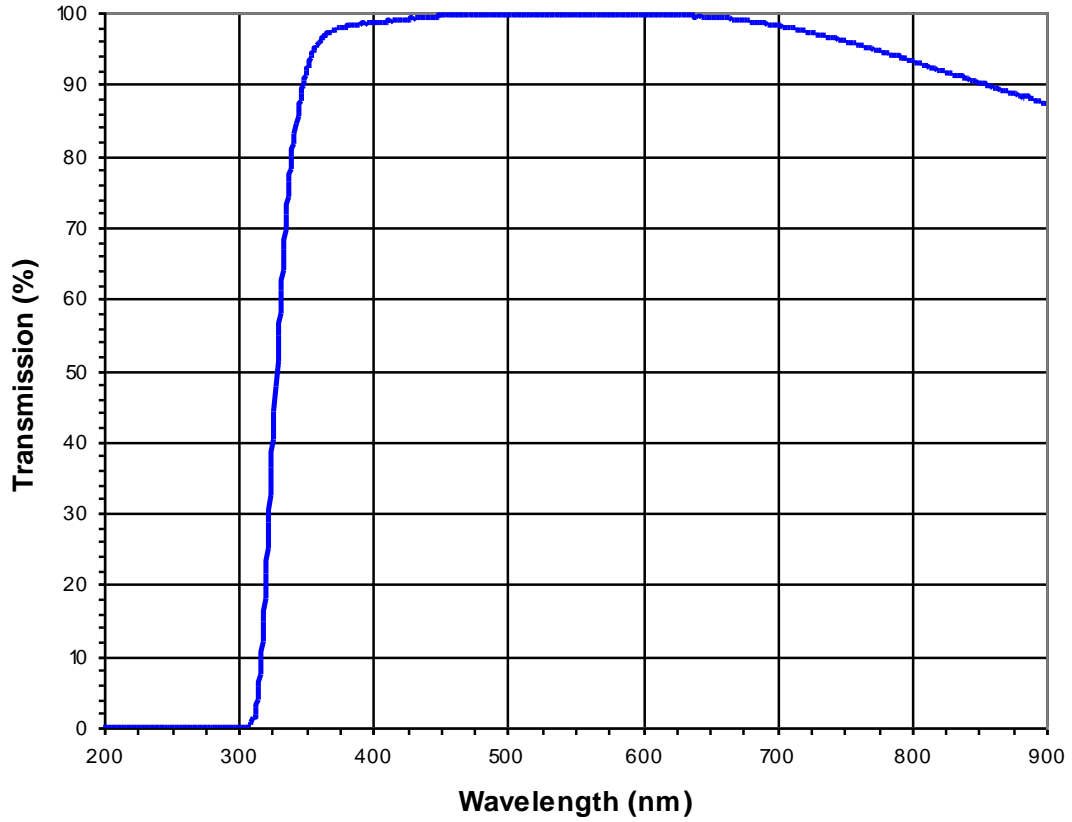

Figure 47: Glass Transmission

Quality Assurance and Reliability

QUALITY AND RELIABILITY

All image sensors conform to the specifications stated in this document. This is accomplished through a combination of statistical process control and visual inspection and electrical testing at key points of the manufacturing process, using industry standard methods. Information concerning the quality assurance and reliability testing procedures and results are available from Truesense Imaging upon request. For further information refer to Application Note *Quality and Reliability*.

REPLACEMENT

All devices are warranted against failure in accordance with the *Terms of Sale*. Devices that fail due to mechanical and electrical damage caused by the customer will not be replaced.

LIABILITY OF THE SUPPLIER

A reject is defined as an image sensor that does not meet all of the specifications in this document upon receipt by the customer. Product liability is limited to the cost of the defective item, as defined in the *Terms of Sale*.

LIABILITY OF THE CUSTOMER

Damage from mishandling (scratches or breakage), electrostatic discharge (ESD), or other electrical misuse of the device beyond the stated operating or storage limits, which occurred after receipt of the sensor by the customer, shall be the responsibility of the customer.

TEST DATA RETENTION

Image sensors shall have an identifying number traceable to a test data file. Test data shall be kept for a period of 2 years after date of delivery.

MECHANICAL

The device assembly drawing is provided as a reference.

Truesense Imaging reserves the right to change any information contained herein without notice. All information furnished by Truesense Imaging is believed to be accurate.

Life Support Applications Policy

Truesense Imaging image sensors are not authorized for and should not be used within Life Support Systems without the specific written consent of Truesense Imaging, Inc.

Revision Changes

MTD/PS-1062

Revision Number	Description of Changes
1.0	<ul style="list-style-type: none"> Initial release
2.0	<ul style="list-style-type: none"> Ordering Information - Corrected Product Name descriptions for Standard Grade parts.
3.0	<ul style="list-style-type: none"> Added the note "Refer to Application Note <i>Using Interline CCD Image Sensors in High Intensity Visible Lighting Conditions</i>" to the following sections <ul style="list-style-type: none"> DC Bias Operating Conditions AC Operating Conditions Storage and Handling Changed cover glass material to D263T eco or equivalent

PS-0015

Revision Number	Description of Changes
1.0	<ul style="list-style-type: none"> Initial release with new document number, updated branding and document template Updated <i>Storage and Handling</i> and <i>Quality Assurance and Reliability</i> sections Reorganized structure for consistency with other Interline Transfer CCD documents