

UNIQA+ 16k CL
Cmos Monochrome Camera



User Manual

Summary

1	<i>CAMERA OVERVIEW</i>	4
1.1	Features	4
1.2	Key Specifications	4
1.3	Description	5
1.4	Typical Applications	5
1.5	Models	5
2	<i>CAMERA PERFORMANCES</i>	6
2.1	Camera Characterization	6
2.3	Response & QE curves	7
2.3.1	Quantum Efficiency	7
2.3.2	Spectral Response	7
3	<i>CAMERA HARDWARE INTERFACE</i>	8
3.1	Mechanical Drawings	8
3.2	Input/output Connectors and LED	9
3.2.1	Power Connector	10
3.2.2	Status LED Behaviour	11
3.2.3	CameraLink Output Configuration	11
4	<i>STANDARD CONFORMITY</i>	12
4.1	CE Conformity	12
4.2	FCC Conformity	12
4.3	RoHs Conformity	12
5	<i>GETTING STARTED</i>	14
5.1	Out of the box	14
5.2	Setting up in the system	14
6	<i>CAMERA SOFTWARE INTERFACE</i>	15
6.1	Control and Interface	15
6.2	Serial Protocol and Command Format	16
6.2.1	Syntax	16
6.2.2	Command Processing	16
6.2.3	GenICam ready	16
6.3	Camera Commands	17
6.3.1	Information	17
6.3.2	Image Format	19
6.3.3	Acquisition Control	21
6.3.4	Gain and Offset	22
6.3.5	Flat Field Correction	25
6.3.5.1	Activation and Auto-Adjust	27
6.3.5.2	Automatic Calibration	28
6.3.5.3	Manual Flat Field Correction	29
6.3.5.4	FFC User Bank Management	30
6.3.6	Look Up Table	31
6.3.7	Statistics and Line Profile	33

6.3.8	Privilege Level.....	34
6.3.9	Save & Restore Settings.....	35
7	<i>APPENDIX A: Test Patterns</i>	36
7.1	Test Pattern 1: Vertical wave.....	36
7.2	Test Pattern 2: Fixed Horizontal Ramps.....	36
7.2.1	In 8 bits (Full) format.....	36
7.2.2	In 12 bits (Medium) format.....	37
8	<i>APPENDIX B: Timing Diagrams</i>	38
8.1	Synchronization Modes with Variable Exposure Time.....	38
8.2	Synchronisation Modes with Maximum Exposure Time.....	39
8.3	Timing Values.....	39
9	<i>APPENDIX C: CameraLink Data Cables</i>	40
10	<i>APPENDIX D: Lenses Compatibility</i>	41
11	<i>APPENDIX E: TROUBLESHOOTING</i>	43
11.1	Camera.....	43
11.2	CommCam Connection.....	43
12	<i>APPENDIX F: Command Summary Tables</i>	44
12.1	Device Control.....	44
12.2	Image Format.....	44
12.3	Synchro and Acquisition.....	45
12.4	Gain & Offset.....	45
12.5	Flat Field Correction.....	46
12.6	LUT.....	46
12.7	Save and Restore.....	47
12.8	Camera Status.....	47
12.9	communication.....	47
12.10	Line Profile Average.....	48
13	<i>APPENDIX G: Revision History</i>	49

1 CAMERA OVERVIEW

1.1 Features

- Cmos Sensor 16384 Pixels, 5 x 5µm
- Interface : Medium/Full/ Full+ (10 Taps) CameraLink®, 85MHz per Channel
- Line Rate : Up to 50000 l/s
- Data Rate : Up to 850 MB/s
- Bit Depth : 8 or 12bits
- Flat Field Correction
- Look Up Table
- Low Power Consumption : <13W
- Compliant with Standard Lenses of the Market



1.2 Key Specifications

Note : All values in LSB is given in 12 bits format

Characteristics	Typical Value	Unit
Sensor Characteristics at Maximum Pixel Rate		
Resolution	16384	Pixels
pixel size (square)	5 x 5	µm
Max line rate – CameraLink Full+ 10 x 85MHz	50	
Max line rate – CameraLink Full 8 x 85MHz	40	kHz
Max line rate – CameraLink Medium 4 x 85MHz	20	
Radiometric Performance at Maximum Pixel Rate and minimum camera gain		
Bit depth	8, 12	Bits
Response (broadband)	112	LSB/(n)/cm²
Full Well Capacity	13500	electrons
Response non linearity	0,3	%
PRNU HF Max	3	%
Dynamic range	67,6	dB

Functionality (Programmable via Control Interface)		
Analog Gain	Up to 12 (x4)	dB
Offset	-4096 to +4096	LSB
Trigger Mode	Timed (Free run) and triggered (Ext Trig, Ext ITC) modes	
Mechanical and Electrical Interface		
Size (w x h x l)	100 x 156 x 36	mm
Weight	700	g
Lens Mount	M95x1	-
Sensor alignment (see chapter 4)	±100	µm
Sensor flatness	±35	µm
Power supply	Single 12 DC to 24 DC	V
Power dissipation - CameraLink	< 13	W
General Features		
Operating temperature	0 to 55 (front face) or 70 (Internal)	°C
Storage temperature	-40 to 70	°C
Regulatory	CE, FCC and RoHS compliant	

1.3 Description

e2v's next generation of line scan cameras are setting new, high standards for line rate and image quality. Thanks to e2v's recently developed CMOS technology, the camera provides 50 000 lines/s in a 16k pixel format and combines high response with an extremely low noise level; this delivers high signal to noise ratio even when short integration times are required or when illumination is limited. The 5µm pixel size is arranged in one single active line, ensuring optimal spatial resolution in both scanning and sensor directions with off-the-shelf lenses.

1.4 Typical Applications

- Flat Panel Color Filter Inspection
- PCB Inspection
- Solar Cell Inspection
- Glass Inspection
- Print Inspection

1.5 Models

EV71YC1MCL1605-BA0 : 16384 Pixels 5x5µm CameraLink 50kl/s

2 CAMERA PERFORMANCES

2.1 Camera Characterization

	Unit	Gain x1 (0dB)			Gain x2 (6dB)			Gain x4 (12dB)		
		Min	Typ.	Max	Min	Typ.	Max	Min	Typ.	Max
Dark Noise RMS	LSB	-	1,7	2,2	-	3,4	4,4	-	6,8	8,8
Dynamic Range	-	-	2400:1	-	-	1200:1	-	-	600:1	-
Readout Noise	e-	-	5,7	-	-	5,7	-	-	5,7	-
Full Well Capacity	e-	-	13650	-	-	13650	-	-	13650	-
SNR	dB	-	40	-	-	37	-	-	34	-
Peak Response (660nm)	LSB/ (n)/cm ²	-	137	-	-	274	-	-	547	-
Non Linearity	%	-	0,3	-	-	0,3	-	-	0,3	-
Without Flat Field Correction :										
FPN rms	LSB	-	0,4	1,5	-	0,7	1,5	-	0,8	1,5
FPN pk-pk	LSB	-	3,2	15	-	5	15	-	5,6	15
PRNU hf (3/4 Sat)	%	-	0,13	0,25	-	0,1	0,25	-	0,1	0,25
PRNU pk-pk (3/4 Sat)	%	-	1	3	-	0,8	3	-	0,8	3

Test conditions :

- Figures in LSB are for a 12bits format.
- Measured at exposure time = 50µs and line period = 50µs in Ext Trig Mode (Max Exposure Time)
- Maximum data rate
- Stabilized temperature 30/40/55 °C (Room/Front Face/Internal)
- SNR Calculated at 75% Vsat with minimum Gain.

2.3 Response & QE curves

2.3.1 Quantum Efficiency

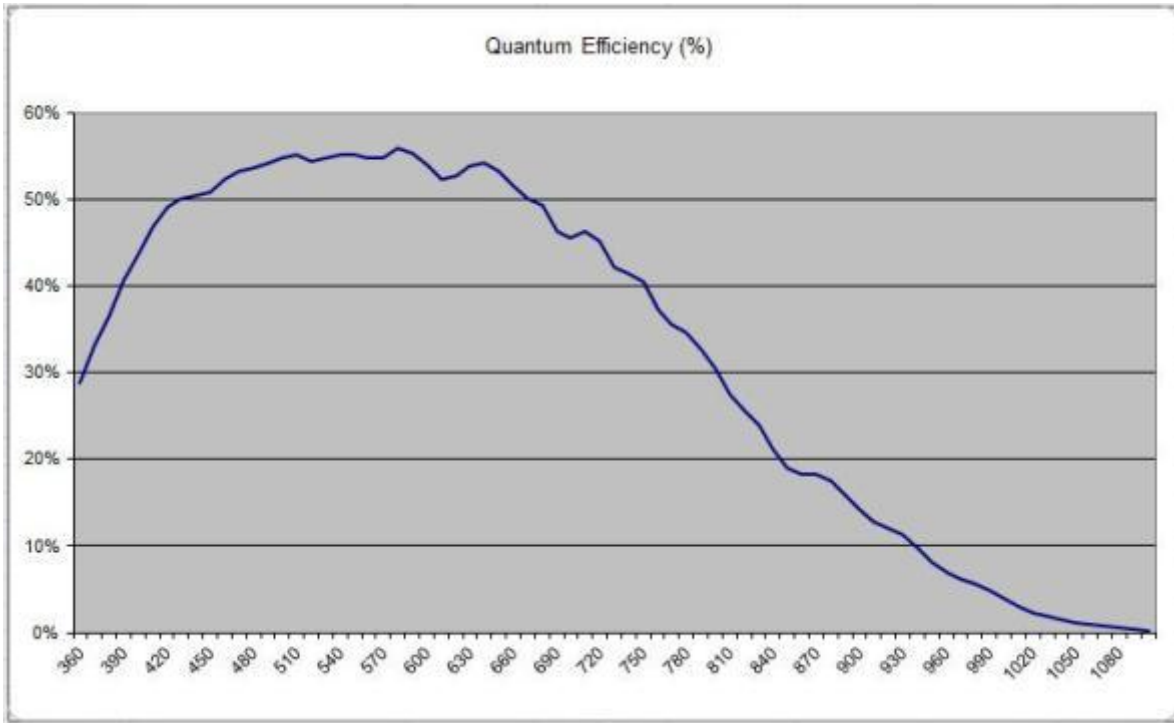

2.3.2 Spectral Response

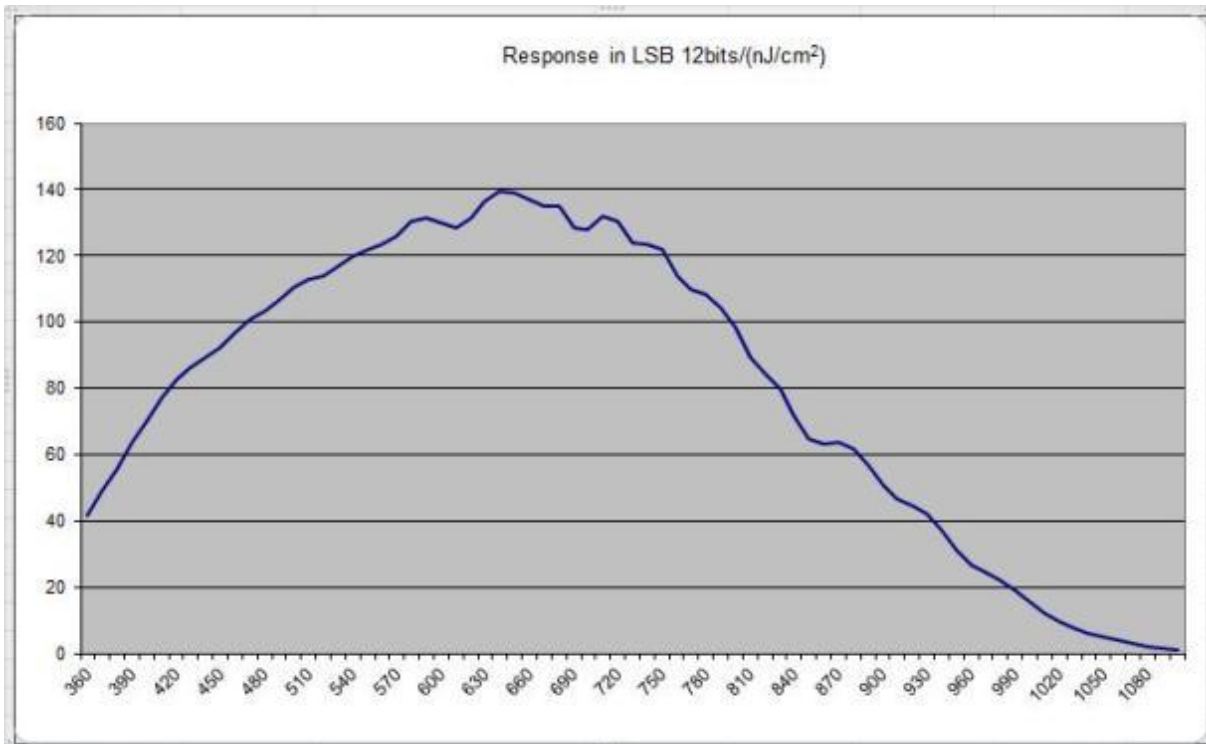

3 CAMERA HARDWARE INTERFACE

3.1 Mechanical Drawings

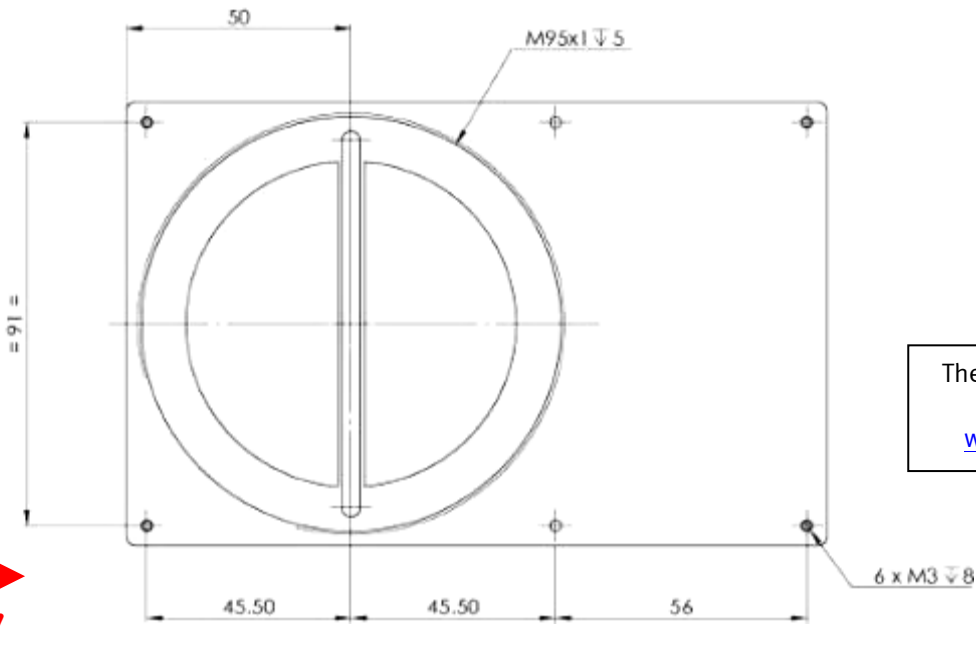
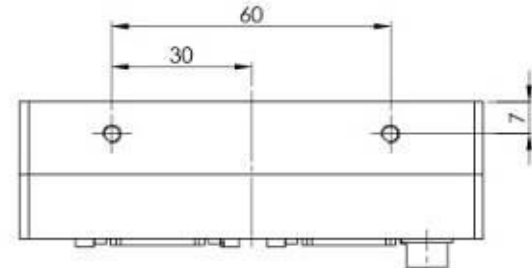
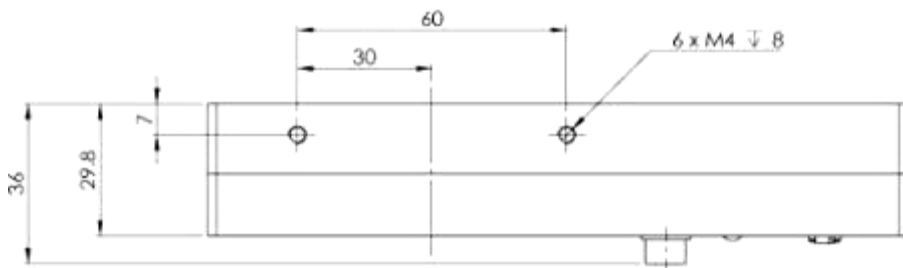
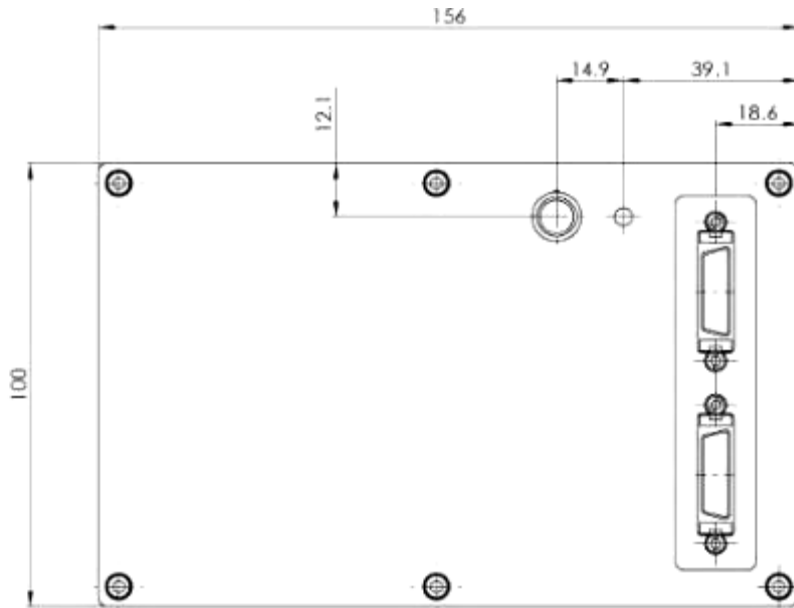

The Step file is available on the web :
www.e2v.com/cameras

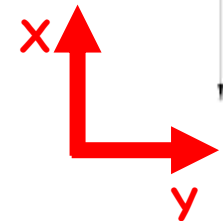

Sensor alignment	
Z = -9.4 mm	±100µm
X = 9 mm	±100 µm
Y = 50mm	±100 µm
Flatness	±25 µm
Rotation (X,Y plan)	±0,1°
Tilt (versus lens mounting plane)	50µm

3.2 Input/output Connections

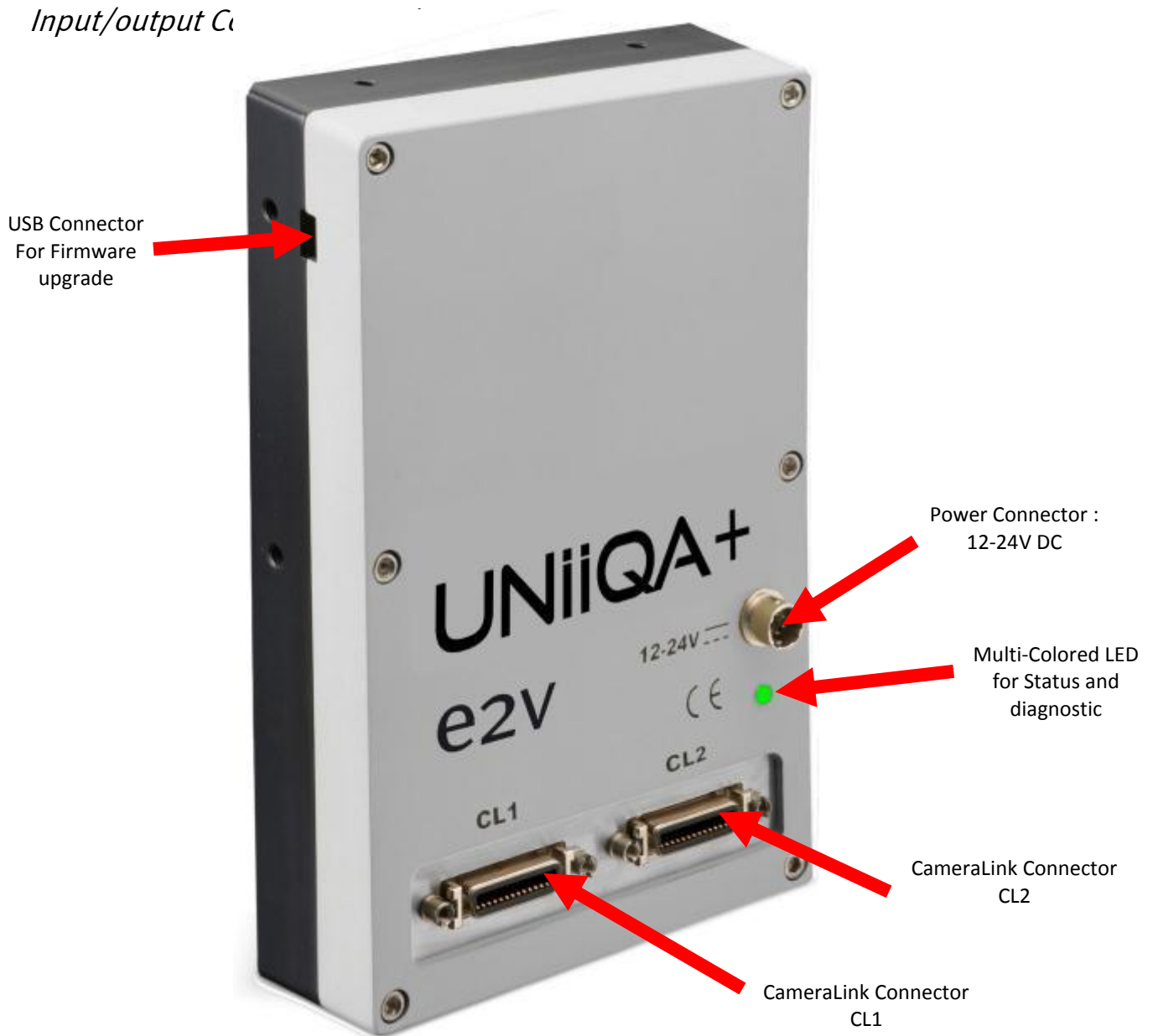

3.2.1 Power Connector

Camera connector type: Hirose HR10A-7R-6PB (male)

Cable connector type: Hirose HR10A-7P-6S (female)

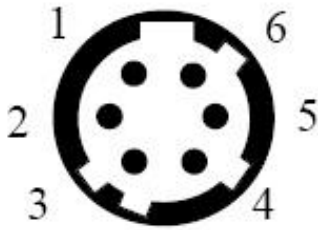

Camera side description

Signal	Pin	Signal	Pin
PWR	1	GND	4
PWR	2	GND	5
PWR	3	GND	6

Power supply from 12 to 24v

Power 13W max with an typical inrush current peak of **1,8A** during power up

Typical values	Current consumption	
	12V	24V
UNIQA+ CL (normal)	1,06A	0,54A
UNIQA+ CL (Standby)	0,47A	0,25A

Power up Time : Around 43s (Green Light)

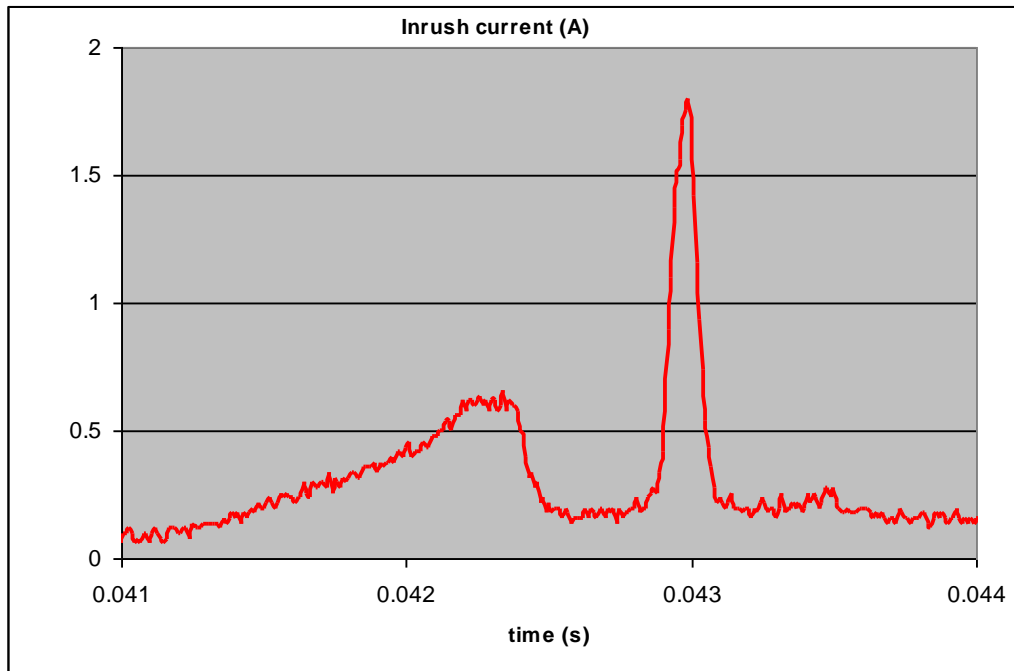

3.2.2 Status LED Behaviour

After less than 2 seconds of power establishment, the LED first lights up in ORANGE. Then after a Maximum of 30 seconds, the LED must turn in a following colour :

Colour and state	Meaning
Green and continuous	OK
Green and blinking slowly	Waiting for Ext Trig (Trig1 and/or Trig2)
Red and continuous	Camera out of order : Internal firmware error

3.2.3 CameraLink Output Configuration

	Connector CL1 + CL2	Pixels per Channel
Medium CameraLink Mode		
4 Channels 8bits	4 x 85MHz	4 x 4096
4 Channels 12bits	4 x 85MHz	4 x 4096
Full CameraLink Mode		
8 Channels 8bits	8 x 85MHz	8 x 2048
Full + CameraLink Mode		
10 Channels 8bits	10 x 85MHz	10 x 1638

4 STANDARD CONFORMITY

The UNIIQA+ cameras have been tested using the following equipment:

- A shielded power supply cable
- A Camera Link data transfer cable ref. 14B26-SZLB-500-OLC(3M)

e2v recommends using the same configuration to ensure the compliance with the following standards.

4.1 CE Conformity

The UNIIQA + cameras comply with the requirements of the EMC (European) directive 2004/108/CE (EN50081-2, EN 61000-6-2).

4.2 FCC Conformity

The UNIIQA + cameras further comply with Part 15 of the FCC rules, which states that: Operation is subject to the following two conditions:

- This device may not cause harmful interference, and
- This device must accept any interference received, including interference that may cause undesired operation

This equipment has been tested and found to comply with the limits for Class A digital device, pursuant to part 15 of the FCC rules. These limits are designed to provide reasonable protection against harmful interference when the equipment is operated in a commercial environment. This equipment generates, uses and can radiate radio frequency energy and, if not installed and used in accordance with the instruction manual, may cause harmful interference to radio communications. Operation of this equipment in a residential area is likely to cause harmful interference in which case the user will be required to correct the interference at his own expense.

Warning: Changes or modifications to this unit not expressly approved by the party responsible for compliance could void the user's authority to operate this equipment.

4.3 RoHS Conformity

UNIIQA + cameras comply with the requirements of the RoHS directive 2011/65/EU.



EU Declaration of Conformity

Declaration Number: NE31S208701

We,

e2v semiconductors
rue de Rochepleine
38120 Saint-Egrève
France

declare the product(s)

Product Family:

UNIQA+ 16k Cameras

Model Identification:

EV71YC1MCL1605-Bxx
x = 0-9-A-Z

in conformance with the requirements of the following standards:

EN55022 : ed. 2006, A class

EN61000-6-2 : ed. 2005

IEC 61000-4-2 : ed.2009

IEC 61000-4-3 : ed.2006 + A1/2008 +A2/2011

IEC 61000-4-4 : ed.2004

IEC 61000-4-5 : ed.2006

IEC 61000-4-6 : ed.2009

IEC 61000-4-11 : ed.2004

when used in conformity with the recommended set-up (as per the Product Specification or Data Sheet).

applicable to:

Information Technology Equipments (I.T.E.)

This (These) product(s) complies(y) with the requirements of the:

- Electromagnetic Compatibility Directive 2004/108/EC,
- CE Marking European Directive 93/68/EEC

and carry the CE marking accordingly.

Saint-Egrève, France, on August 23rd, 2013

Martine WOOLF,
Quality Manager

5 GETTING STARTED

5.1 Out of the box

The contains of the Camera box is the following :

- One Camera UNIQA+



There is no CDROM delivered with the Camera : Both User Manual (this document) and CommCam control software have to be downloaded from the web site : This ensure you to have an up-to-date version.

Main Camera page : www.e2v.com/cameras

On the appropriate Camera Page (UNIQA+) you'll find a download link first version of CommCam compliant is indicated in the last Chapter CommCam download requires a login/password :

- Login : [commcam](#)
- Password : [chartreuse](#)



5.2 Setting up in the system

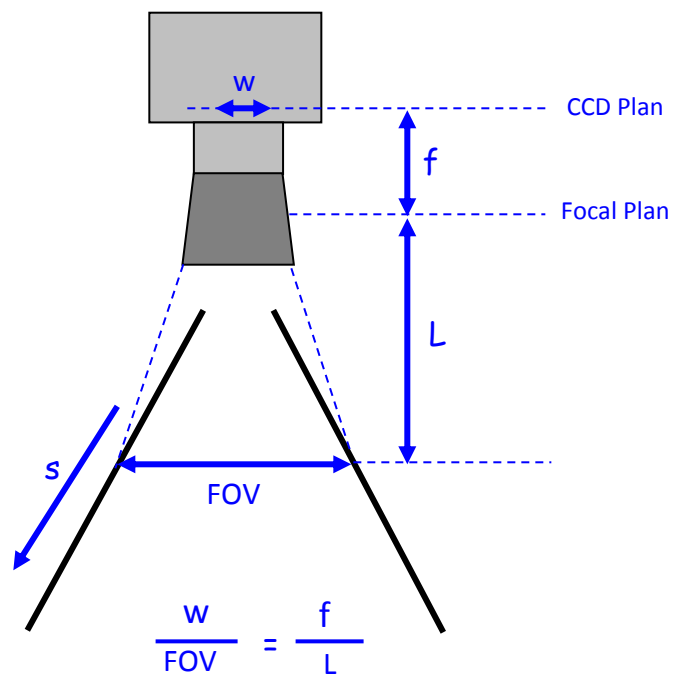
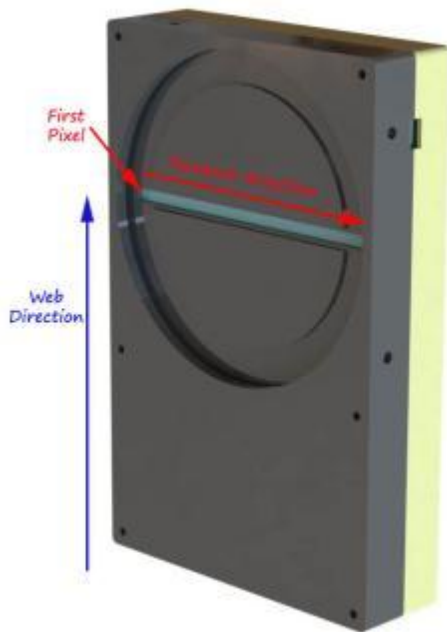

The Compliant Lenses and their accessories are detailed in Appendix C

6 CAMERA SOFTWARE INTERFACE

6.1 Control and Interface

As all the e2v Cameras, the UNIIQA+ CL is delivered with the friendly interface control software COMMCAM.UCL (as “Ultimate Camera Link”) which is based on the GenICam standard
 COMMCAM recognizes and detects automatically all the UCL Cameras connected on any transport layers (Camera Link or COM ports) of your system.
 Once connected to the Camera you have an easy access to all its features. The visibility of these features can be associated to three types of users: Beginner, Expert or Guru. Then you can make life easy for simple users.
 Minimum version of CommCam is 2.2.2 in order to recognize the UNIIQA +



6.2 Serial Protocol and Command Format

The Camera Link interface provides two LVDS signal pairs for communication between the camera and the frame grabber. This is an asynchronous serial communication based on RS-232 protocol.

The serial line configuration is:

- Full duplex/without handshaking
- 9600 bauds (default), 8-bit data, no parity bit, 1 stop bit. The baud rate can be set up to 115200

6.2.1 Syntax

Internal camera configurations are activated by write or readout commands.

The command syntax for write operation is:

w <command_name> <command_parameters>CR

The command syntax for readout operation is:

r <command_name>CR

6.2.2 Command Processing

Each command received by the camera is processed:

- The setting is implemented (if valid)
- The camera returns ">"<return code>CR

The camera return code has to be received before sending a new command.



The camera return code has to be received before sending a new command. Some commands are longer than the others : Waiting for the return code ensure a good treatment of all the commands Without saturating the buffer of the camera

Table 5-1. Camera Returned Code

Returned code	meaning
>0	(or "OK") : All right, the command will be implemented
>3	Error Bad CRC (for write command only)
>16	Invalid Command ID (Command not recognize or doesn't exist)
>33	Invalid Access (the receipt of the last command has failed).
>34	Parameter out of range (the parameter of the last command send is out of range).
>35	Access Failure (bad communication between two internal devices).

6.2.3 GenICam ready



The CameraLink Standard is not yet compliant with GenICam Standard, but as much as possible, each command of the UNIQA+ will have its correspondence with the Standard Feature Naming Convention of the GenICam Standard.

This correspondence is given in parenthesis for each feature/command as the following example :

- **Vendor name** (*DeviceVendorName*) : "e2v"

6.3 Camera Commands

6.3.1 Information

These values allow to identify the Camera. They can be accessed in CommCam software in the “Info” section
All these values are fixed in factory and can’t be changed (shaded) except the Camera User ID which can be fixed by the Customer :

- **Vendor name** (*DeviceVendorName*) : “e2v”
 - ⇒ Read function : “**r vdnm**”;
 - Returned by the camera : “e2v”, string of 32 bytes (including “/o”)
 - ⇒ Cannot be written
- **Model Name** (*DeviceModelName*) : Internal name for GenICam :
 - ⇒ Read function : “**r mdnm**”;
 - Returned by the camera : String of 32 bytes (including “/o”) :
 - ⇒ Cannot be written
- **Device Manufacturer Info** (*DeviceManufacturerInfo*) : Get Camera ID
 - ⇒ Read function : “**r idnb**”;
 - Returned by the camera : String of 128 bytes (including “/o”)
 - ⇒ Cannot be written
- **Device Version** (*DeviceVersion*) : Get Camera Hardware version
 - ⇒ Read function : “**r dhvw**”;
 - Returned by the camera : String of 32 bytes (including “/o”)
 - ⇒ Cannot be written
- **Device Firmware Version** (*DeviceFirmwareVersion*): Get camera synthetic firmware
 - ⇒ Read function : “**r dfvw**”;
 - Returned by the camera : String of 16 bytes (including “/o”)
 - ⇒ Cannot be written
- **Device SFNC Version : 1.5.0**
These Parameters (Major, Minor, Sub Minor) are only virtual ones in order to give the SFNC compliance of the Camera.
- **Device ID** (*DeviceID*) : Camera Factory identifier ID
 - ⇒ Read function : “**r cust**”;
 - Returned by the camera : String of 128 bytes (including “/o”)
 - ⇒ Write function : “**w cust <idstr>**”
- **Device User ID** (*DeviceUserID*) : Camera user identifier ID
 - ⇒ Read function : “**r cust**”;
 - Returned by the camera : String of 128 bytes (including “/o”)
 - ⇒ Write function : “**w cust <idstr>**”
- **Electronic board ID** (*ElectronicBoardID*) : Get PcB Board ID
 - ⇒ Read function : “**r boid**”;
 - Returned by the camera : String of 32 bytes (including “/o”)
 - ⇒ Can not be written

- **Device Temperature Selector** (*DeviceTemperatureSelector*) : MainBoard
 - ⇒ Can not be written
- **Device Temperature** (*DeviceTemperature*) : Get Main Board Temperature
 - ⇒ Read function : “r temp”;
 - Return by the camera : Temperature in Q10.2 format (8 bits signed + 2 bits below comma). Value is between -512 to 511 in °C.
- **Device Serial Port Selection** : Indicates the Serial Port on which the Camera is connected.
- **Device Serial Port Baud Rate** (*ComBaudRate*): Set the Camera BaudRate
 - ⇒ Read function : “r baud”;
 - Returned by the camera : Value of the Baud Rate
 - ⇒ Write function : “w baud” <index> with the index as follows :
 - 1 : 9600 Bauds (default value at power up)
 - 2 : 19200Bauds
 - 6 : 57600Bauds
 - 12 : 115200Bauds
- **Standby Mode** (*Standby*) : Activation of the Standby mode of the Camera
 - ⇒ Read function : “r stby”;
 - Returned by the camera : Boolean.
 - 0 : Disable Standby mode (False)
 - 1 : Enable standby mode (True)
 - ⇒ Write function : “w stby <val>”; <val> is 0 or 1.



A standby mode, what for ?

The Standby mode stops all activity on the sensor level. The power dissipation drops down to about **6W**. During the standby mode, **the grab is stopped**

Once the Standby mode turned off, the Camera recovers in less than **1ms** to send images again from the sensor.

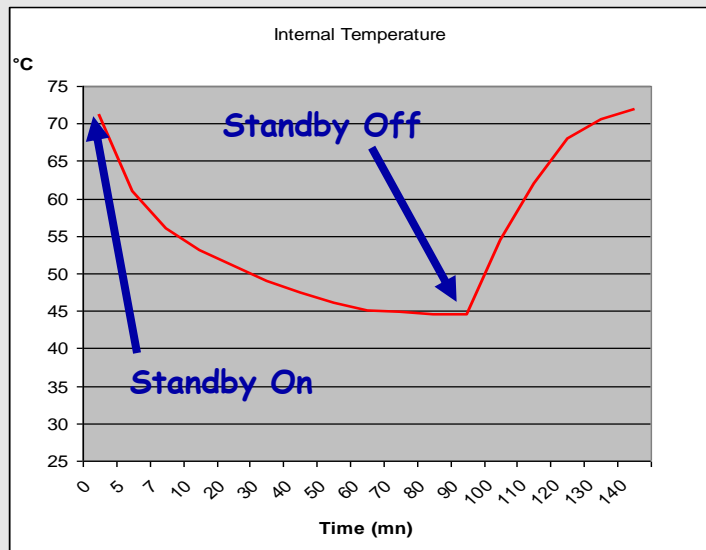

- **Camera status** : Get the Camera status register (32bits Integer)
 - ⇒ Read function : “**r stat**”;
 - Returned by the camera : 32bits integer :
 - **Bit 0** : (*StatusWaitForTrigger*) : True if no trig received from more than 1sec
 - **Bit 1** : (*StatusTriggerTooFast*) : Missing triggers. Trig signal too fast
 - **Bit 2** : (*StatusSensorConnection*) : True is the Sensor pattern is checked as failed.
 - Bit 3, 4, 5, 6, 7 : Reserved
 - **Bit 8** : (*StatusWarningOverflow*) : True is an overflow occurs during FFC or Tap balance processing.
 - **Bit 9** : (*StatusWarningUnderflow*) : True is an underflow occurs during FFC or Tap balance processing
 - Bits 10 : Reserved
 - **Bits 11** : Scrolling Direction : 0 = Forward, 1 = Reverse. Updated only by external CC3 (CameraLink)
 - Bits, 12, 13, 14, 15 : Reserved
 - **Bit 16** : (*StatusErrorHardware*) : True if hardware error detected
 - Bits 17 to 31 : Reserved

6.3.2 Image Format

- **Sensor Width** (*SensorWidth*) : Get the physical width of the Sensor. This value is available in the CommCam “Image Format Control” section :
 - ⇒ Read function : “**r snsW**”;
 - Return by the sensor : Integer 16384.
 - ⇒ Can not be written;
- **Sensor Height** (*SensorHeight*) : Get the physical height of the Sensor. This value is available in the CommCam “Image Format Control” section :
 - ⇒ No Access. Virtual command in xml”; Value always = 1
- **Width Max** (*WidthMax*) : Get the Maximum Width of the Sensor. This value is available in the CommCam “Image Format Control” section :
 - ⇒ No Access. The value is mapped on “SensorWidth”
- **Height Max** (*HeightMax*) : Get the Maximum height of the Sensor. This value is available in the CommCam “Image Format Control” section :
 - ⇒ No Access. Virtual command in xml”; Value always = 1
- **Output mode** (*OutputMode*) : Set the CameraLink Output mode (refer also to Chap 3. : CameraLink Output Configuration). This command is available in the CommCam “Image Format Control” section :
 - ⇒ Read function : “**r mode**”;
 - Returned by the camera : Output mode from 0 to 3 (see table below).
 - ⇒ Write function : “**w mode**” <value> :
 - detailed in the table below :

Modes	Connector CL1	Mode value
Medium 4 Outputs 8bits	4 x 85MHz 8 bits	0
Medium 4 Outputs 12bits	4 x 85MHz 12 bits	1
Full 8 Outputs 8bits	8 x 85MHz 8 bits	2
Full+ 10 Outputs 8bits	10 x 85MHz 8 bits	3



Structure of the Camera Link Channels for interfacing

➤ Medium Mode 4x4096 Pixels at 85MHz each Channel

4 Taps Separate, from Left to Right

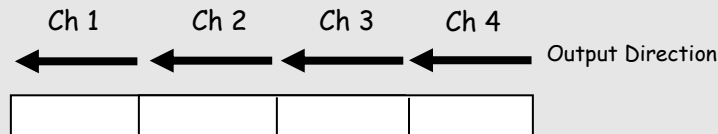

➤ FULL Mode 8x2048 Pixels at 85MHz each Channel

8 Taps Separate, from Left to Right

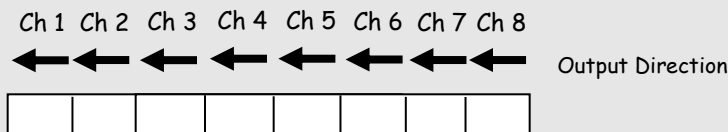

➤ FULL+ Mode 10x1638 Pixels at 85MHz each Channel

10 Taps Separate, from Left to Right :

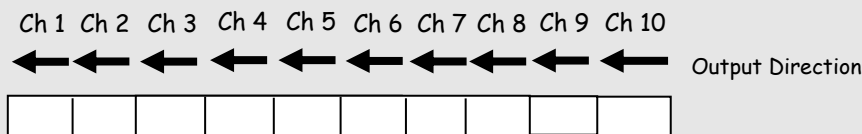

- **Output Frequency (*OutputFrequency*)** : Get the CameraLink Data Output Frequency. This value is available in the CommCam “Image Format Control” section :
 - ⇒ Read function : “**r clfq**”;
 - Return by the Camera : 0 (Frequency = 85MHz)
 - ⇒ Can not be written;
- **Reverse Reading (X) (*ReverseReading*)** : Allows to output the line in the Reverse-X direction. This value is available in the CommCam “Image Format Control” section :
 - ⇒ Read function : “**r revr**”;
 - Return by the Camera : 0 or 1 (enabled/disabled)
 - ⇒ Write function : “**w revr <value>**”;
 - “0” : Disabled.
 - “1” : Enables the reverse reading out (see below for “normal” direction)
- **Test Image Selector (*TestImageSelector*)** : Defines if the data comes from the Sensor or the FPGA (test Pattern). This command is available in the CommCam “Image Format” section :
 - ⇒ Read function : “**r srce**”;
 - Returned by the camera : “0” if Source from the Sensor and “1 to 5” if test pattern active
 - ⇒ Write function : “**w srce <value>**” :
 - “0” : To switch to CCD sensor image
 - “1” : Grey Horizontal Ramp (Fixed) : **See AppendixA**
 - “2” : White Pattern (Uniform white image : 255 in 8Bits or 4095 in 12bits)
 - “3” : Grey Pattern (Uniform middle Grey : 128 in 8bits or 2048 in 12 bits)
 - “4” : Black Pattern (Uniform black : 0 in both 8 and 12 bits)
 - “5” : Grey vertical Ramp (moving)

The test pattern is generated in the FPGA : It’s used to point out any interface problem with the Frame Grabber. When any of the Test pattern is enabled, the whole processing chain of the FPGA is disabled.

6.3.3 Acquisition Control

This section deals with all the Exposure, Line period and synchronisation modes

- **Synchronisation Mode** ([TriggerPreset](#)) : Timed or Triggered, it defines how the grabbing is synchronized. This command is available in the CommCam “Acquisition Control” section :
 - ⇒ Read function : “**r sync**”;
 - Returned by the camera :
 - “0” : Internal Line Trigger with Exposure time Internally Controlled (Free Run). “1” : External Trigger with Exposure Time Internally Controlled
 - “2” : External Trigger with maximum Exposure time
 - “3” : One External with Exposure Time Externally Controlled. The same Trigger signal defines the line period and its low level defines the exposure time.
 - “4” : Two External Triggers with Exposure Time Externally Controlled : CC2 defines the start of the exposure (and also the start Line) and CC1 defines the Stop of the exposure.
 - “5” : Internal Line Trigger with maximum Exposure Time
 - ⇒ Write function : “**w sync**” <value>



The Timing diagrams associated to each Synchronization mode and the Timing values associated are detailed in the APPENDIX B of this document.

- **Exposure time** ([ExposureTime](#)): Defines the exposure time when set in the Camera. This command is available in the CommCam “Acquisition Control” section :
 - ⇒ Read function : “**r tint**”;
 - Returned by the camera : Integer from 15 to 65535 (=1,5µs to 6553,5µs by step 0,1µs)
 - ⇒ Write function : “**w tint**” <value> ;

This value of exposure time is taken in account only when the synchronisation mode is “free run” (0) or “Ext Trig with Exposure time set” (1). Otherwise it’s ignored.



Due to the limitation of the timing pixel inside the sensor, the Exposure time has to be set by taking in account the limitation detailed in the APPENDIX B of this document.
The **Minimum exposure time** which can be set is : **1,5µs**

- **Line Period** ([LinePeriod](#)) : Defines the Line Period of the Camera in Timed mode. This command is available in the CommCam “Acquisition Control” section :
 - ⇒ Read function : “**r tper**”;
 - Returned by the camera : Integer from 1 to 65536 (=0,1µs to 6553,6µs by step 0,1µs)
 - ⇒ Write function : “**w tper**” <value> ;

The line period is active only in Free Run modes. It’s also disabled if in this mode, the Integration time is set higher than the Line Period.



Minimum Line Period

Medium modes (4 Taps) : **50µs**
Full Mode (8 Taps) : **25µs**
Full+ Mode (10 Taps) : **20µs**

6.3.4 Gain and Offset

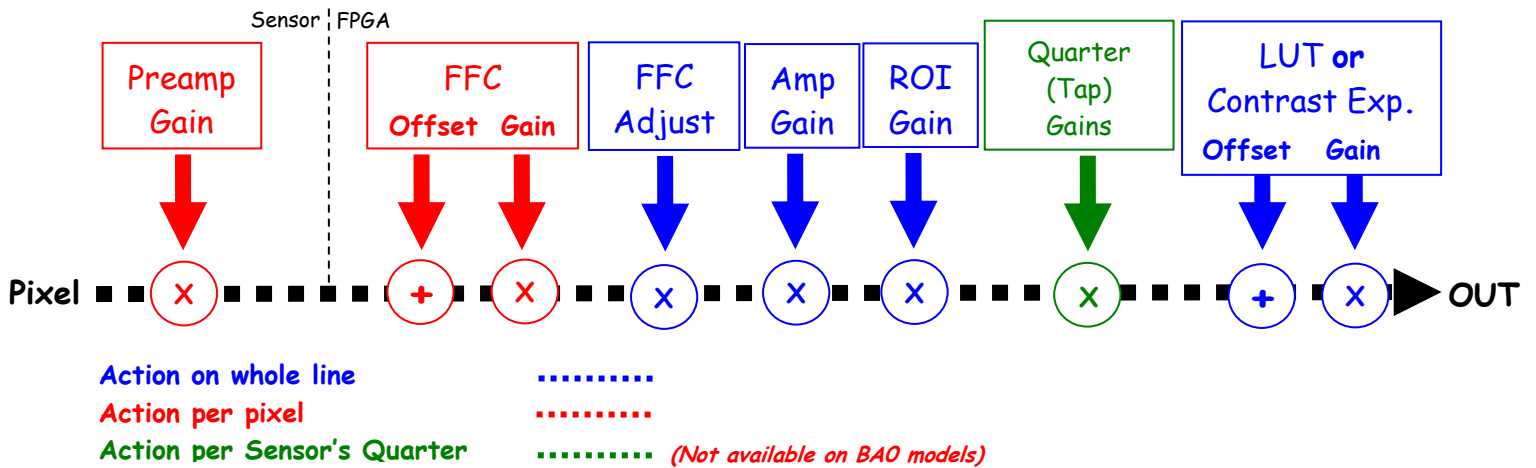

Analog Gain in the ADC

The only analog Gain available in the UNIQA+ is located at the sensor level, in the ADC converter. This "Preamp Gain" is in fact a variation of the ramp of the comparator of the ADC. Then 3 Values are available : x1, x2 and x4. A gain x1 in a 12 bits conversion is equivalent to x4 in 10 bits.

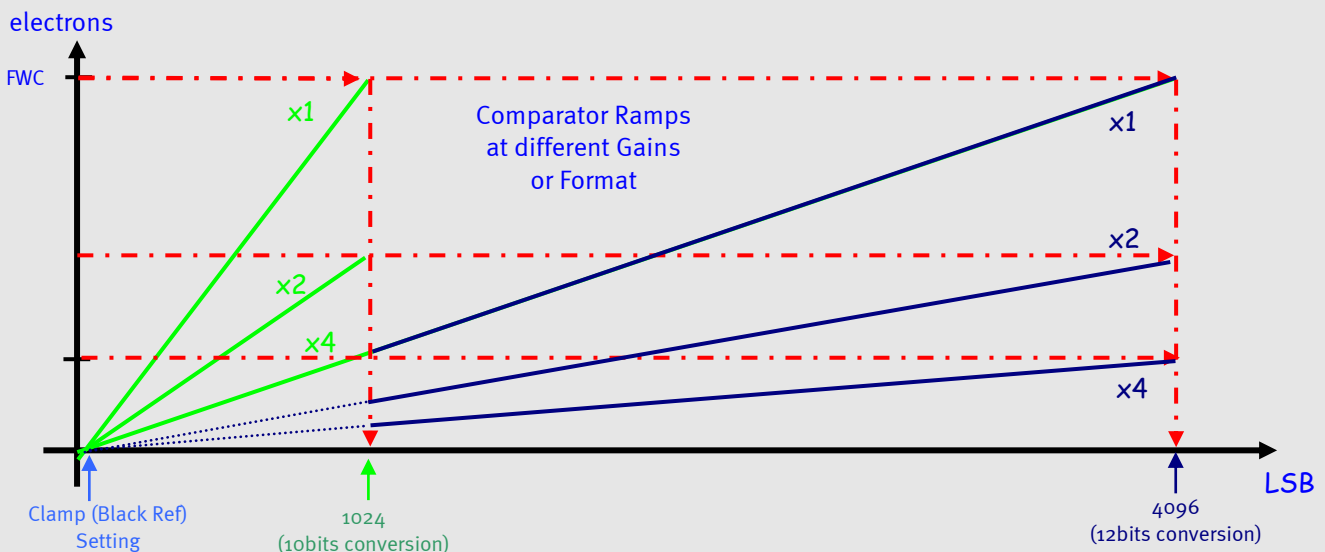

- **Preamp Gain :** (*Gain* with *GainSelector= AnalogAll*)
Set the Pre-amplification Gain. This command is available in the CommCam "Gain & Offset" section.
 - ⇒ Read function : **"r pamp"**;
Returned by the camera : Integer corresponding to one of the 3 different step values :
 - 0 : x1 (0dB)
 - 1 : x2 (6dB)
 - 2 : x4 (12dB)
 - ⇒ Write function : **"w pamp" <int>** ;

- **Gain:** (*Gain* with *GainSelector=GainAll*)
Set the Amplification Gain. This command is available in the CommCam “Gain & Offset” section :
 - ⇒ Read function : “**r gain**”;
Returned by the camera : Value from 0 to 6193 corresponding to a Gain range of 0dB to +8dB calculated as following : $\text{Gain(dB)} = 20 \cdot \log(1 + \text{Gain}/4096)$.
 - ⇒ Write function : “**w gain**” <int>;
- **Tap Gain** (*Gain* with *GainSelector=TapX*) :
 - ⇒ Read function : “**r fga**<tap>”; <tap> is 1 to 4
Returns the Gain value for the tap. Ex : “*r fga1*” returns Gain value Tap1.
 - ⇒ Write function : “**w fga**<tap> <value>”
 - <tap> : 1 to 4
 - <value> : from -128 to +127 by step of 1 (0,0021dB each step)
- **Digital Gain** (*Gain* with *GainSelector=DigitalAll*) : Set the global Digital Gain. This command is available in the CommCam “Gain & Offset” section :
 - ⇒ Read function : “**r gdig**”;
Returned by the camera : Integer value from 0 to 255. The corresponding Gain is calculated as $20 \log(1 + \text{val}/64)$ in dB
 - ⇒ Write function : “**w gdig**” <int>;
- **Digital Offset** (*BlackLevelRaw* with *BlackLevelSelector=All*) : Set the global Digital Offset. This command is available in the CommCam “Gain & Offset” section :
 - ⇒ Read function : “**r offs**”;
Returned by the camera : Value from -4096 to +4095 in LSB
 - ⇒ Write function : “**w offs**” <int>;



The Contrast Expansion (both Digital Gain & Offset) will be automatically disabled if the LUT is enabled..

- **Tap Balance Gains Enable Switch** (*TapBalanceGainEnable*) :
 - ⇒ Read function : “**r tbe**”;
Returns the Gain value for the tap. Ex : “*r fga1*” returns Gain value Tap1.
 - ⇒ Write function : “**w tbe** <val>” with <val> : 0 or 1
 - 0 : Disables the Tap Balance Gains
 - 1 : Enables the Tap Balance Gains
- **ROI Gain 0** : Set the Gain for the ROI Gain feature.
 - ⇒ Read function : “**r roig**”;
Returned by the camera : Value from 0 to 2047 (U1.9) corresponding to a Gain range from x1 to x1,999 and calculated as following : $(1 + \text{Gain}/1024)$.
 - ⇒ Write function : “**w roig**” <value>;
- **ROI Set 0** : Set the ROI and apply the Gain for ROI Gain Feature.
 - ⇒ Read function : “**r rois**”;
Returns the ROI set for the last ROI gain command
 - ⇒ Write function : “**w rois** <val>” with <val> : Hexadecimal combination of Start and Stop address for the ROI (both on 16bits) : *oxStartAdroxStopAdr*
 - Start address : from 0 to 16382 (0x000 to 0x3FFE)
 - Stop address : from 1 to 16383 (0x001 to 0x3FFF)



ROI Gain : How does it works

The ROI Gain feature comes in addition with the FFC (it's applied and calculated after).

The maximum complementary Gain is x2.

It can be applied in 2 commands :

- First, set the ROI Gain value.
 - Second, set the ROI (Region of Interest).
- ⇒ This second command applies the Gain on the ROI in memory and this is immediately activated.
- ⇒ The ROI Gain is a "live" feature that can be overlapped but can't be saved in memory.

Here is an example to apply a complementary gain of x1,5 (512) between the pixels #5263 (0x148F) and #9002 (0x232A), pixels included. The two commands are :

- "w roig 512"
- "w rois 0x148F232A"

Result with FFC activated :

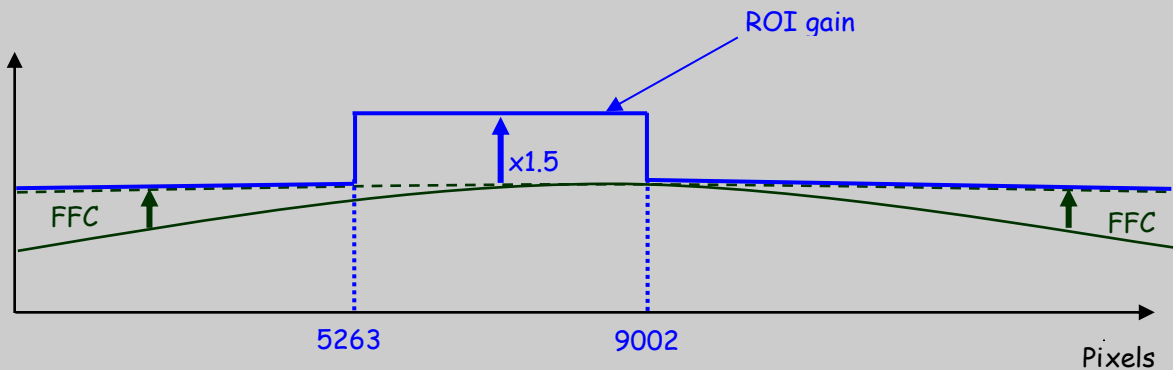

Result with FFC not activated :

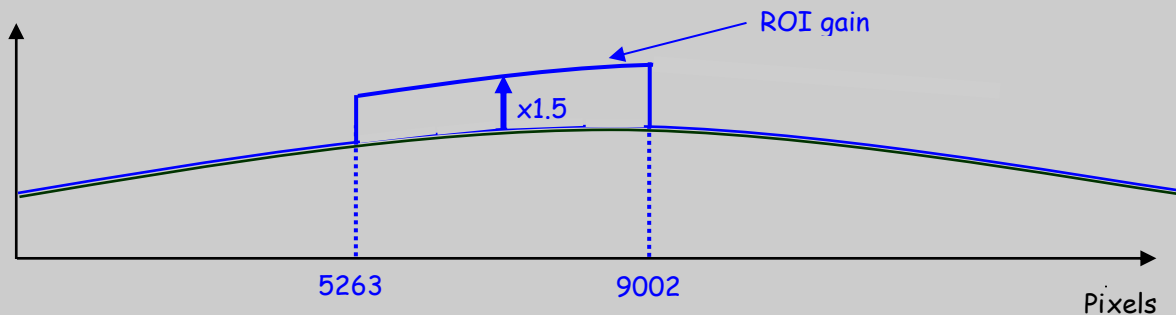

6.3.5 Flat Field Correction



How is performed the Flat Field Correction ?

What is the Flat Field correction (FFC) ?

The Flat Field Correction is a digital correction on each pixel which allows :

- To correct the Pixel PRNU (Pixel Response Non Uniformity) and DSNU (Dark Signal Non Uniformity)
- To Correct the shading due to the lens
- To correct the Light source non uniformity

Before

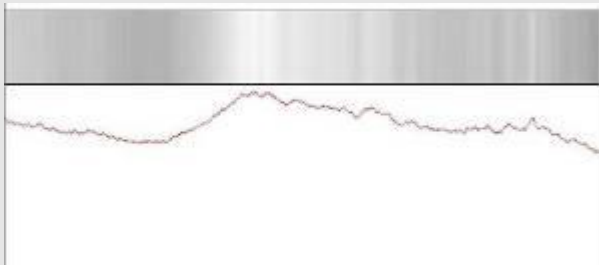

After



How is calculated / Applied the FFC ?

The FFC is a digital correction on the pixel level for both Gain and Offset.

- Each Pixel is corrected with :
 - An Offset on 10 bits (Signed Int S9.1). They cover a dynamic of ± 256 LSB in 12bits with a resolution of 1/2 LSB 12bits. Offset : the MSB is the sign, the rest of 9bits is from 0 .. 256 with precision of 1/2
 - A Gain on 12 bits (Unsigned Int U2.12) with a max gain value of $\times 5^{(*)}$

The calculation of the new pixel value is : $P' = (P + \text{Off}).(1 + \text{Gain}/1024^{(*)})$. Gain : 0 to 4095

The FFC processing can be completed with an automatic adjustment to a global target. This function is designed as “**FFC Adjust**”. This adjustment to a User target is done by an internal hidden gain which is re-calculated each time the FFC is processed while the FFC adjust function is enabled.

The FFC is always processed with the max pixel value of the line as reference. If enabled, the FFC adjust module (located at the output of the FFC module) calculates the adjustment gain to reach the target defined by the User.

When the FFC result is saved in memory, the adjust gain and target are saved in the same time in order to associate this gain value with the FFC result.

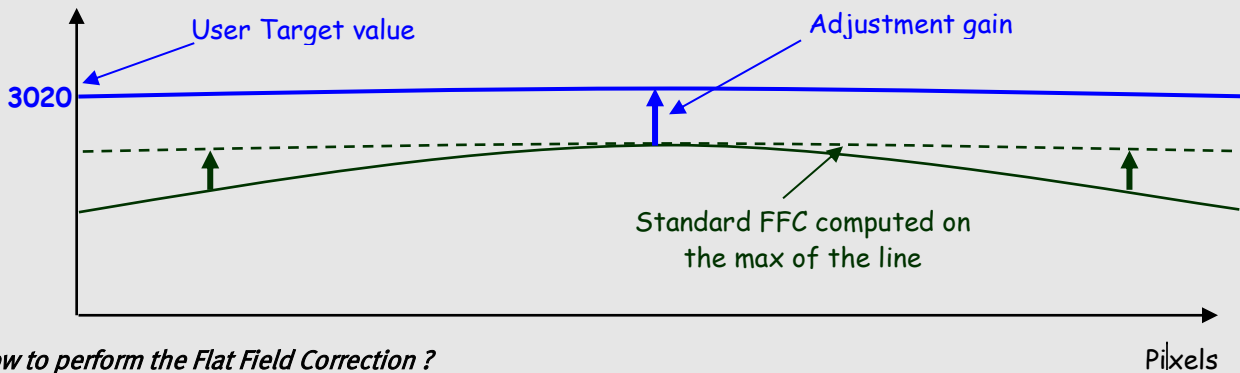

How to perform the Flat Field Correction ?

FPN/DSNU Calibration

- Cover the lens
- Launch the FPN Calibration : Grab and calculation is performed in few seconds

PRNU Calibration

The User must propose a white/gray uniform target to the Camera (not a fixed paper).

The Gain/Light conditions must give a non saturated image in any Line.

The Camera must be set in the final conditions of Light/ Gain and in the final position in the System.

If required, set a user target for the FFC adjust and enable it.

- White uniform (moving) target. Use The FFC Low Band Filter if the Target can't move. This will remove the defects of the target itself
- Launch the FFC
- Enable the FFC
- You can save the FFC result (both FPN+PRNU in the same time) in one of the 8 x FFC User Banks.
- The user target and Gain are saved with the associated FFC in the same memory.

Advices

The UNIQA+ Cameras have 8 x FFC Banks to save 8 x different FFC calibrations. You can use this feature if your system needs some different conditions of lightning and/or Gain because of the inspection of different objects : You can perform one FFC to be associated with one condition of Gain/setting of the Camera (4 Max) and recall one of the four global settings (Camera Configuration + FFC + Line Quarters Balance) when required.

6.3.5.1 Activation and Auto-Adjust

- **FFC Activation** (*FFCEnable*) : Enable/disable the Flat Field Correction. This command is available in the CommCam “Flat Field Correction” section :
 - ⇒ Read function : “**r ffc**” : Returns the FFC Status (0 if disabled, 1 if enabled)
 - ⇒ Write function :
 - “**w ffc 1**” : Enable the FFC.
 - “**w ffc 0**” : Disabled the FFC

- **FFC Adjust Function** : This Feature is available in the CommCam “Flat Field Correction/ Automatic Calibration” section :
 - **Gains adjust** (*FFCAdjust*): Enable/Disable the function
 - ⇒ Read function : “**r ffad**”. Returns the status of the function (0 if disabled)
 - ⇒ Write function :
 - “**w ffad 0**” : Disable the FFC Adjust function.
 - “**w ffad 1**” : Enable the FFC Adjust function.

 - **Auto Adjust Target Level** (*FFCAutoTargetLevel*): set the value for the User Target.
 - ⇒ Read function : “**r tfad**”. Returns the Target value (from 0 to 4095)
 - ⇒ Write function : “**w tfad <value>**” : Set the Target Value (in 12bits)
 - ⇒



FFC Adjust : A good usage.

When there are several Cameras to set up in a system on a single line, the most difficult is to have a uniform lightning whole along the line.

If each Camera performs its own Flat field correction, relative to the max of each pixel line, the result will be a succession of Camera lines at different levels.

⇒ The FFC Adjust function allows to set the same target value for all the Cameras in the system and then to get a perfect uniform line whole along the system with a precision of 1 LSB to the Target.

The Maximum correction is x2 the highest value of the line.

The reasonable value for the User Target is not more than around 20% of the max value of the line.

6.3.5.2 Automatic Calibration

- **FFC Low Band Filter** (*FFCAutoTargetLevel*): set the value for the User Target.
 - ⇒ Read function : “**r lffw**”. Returns the Filter Interval size (from 0 to 255)
 - ⇒ Write function : “**w lffw <value>**” : Set the Interval size for the filter (0 / 1 ... 255)
 - 0 : Disables the FFC Low Band Filter
 - 1 to 255 : Set the interval size (+/- the value around the pixel) for the Low Band filter

When you can't provide a moving Target to the Camera during the PRNU Calibration you can setup the FFC Low Band Filter in order to remove the defect from the Target before calculating the FFC parameters. The Value set in the FFC filter defined the size of the interval around each pixel : The Filter will replace each pixel value by the average on the interval.

- **FPN/DSNU Calibration :**
 - **FPN Calibration Control** (*FPNCalibrationCtrl*) : Launch or abort of the FPN process for the Offsets calculation. These commands are available in the CommCam “Flat Field Correction / Automatic Calibration ” section :
 - ⇒ Read function : “**r calo**” : Returns the FPN Calculation Process Status (0 if finished, 1 if processing)
 - ⇒ Write function :
 - “**w calo 1**” : Launch the FPN Calibration Process.
 - “**w calo 0**” : Abort the FPN Calibration Process.
 - **FPN Coefficient Reset** (*FPNReset*) : Reset the FPN (Offsets) coefficient in Memory. This command is available in the CommCam “Flat Field Correction / Manual Calibration ” section :
 - ⇒ Write function : “**w rsto 0**” : Reset (set to 0) the FPN coefficients in memory. This doesn't affect the FFC User Memory Bank but only the active coefficients in Memory.
- **PRNU Calibration :**
 - **PRNU Calibration Control** (*FFCCalibrationCtrl*) : Launch or abort of the PRNU process for the Gains calculation. This command is available in the CommCam “Flat Field Correction / Automatic Calibration ” section :
 - ⇒ Read function : “**r calg**” : Returns the PRNU Calculation Process Status (0 if finished, 1 if processing)
 - ⇒ Write function :
 - “**w calg 1**” : Launch the PRNU Calibration Process.
 - “**w calg 0**” : Abort the PRNU Calibration Process.
 - **PRNU coefficient Reset** (*PRNUReset*) : Reset the PRNU (Gains) coefficient in Memory. This command is available in the CommCam “Flat Field Correction / Manual Calibration ” section :
 - ⇒ Write function : “**w rstg 0**” : Reset (set to “x1”) the PRNU coefficients in memory. This doesn't affect the FFC User Memory Bank but only the active coefficients in Memory.



Some Warnings can be issued from the PRNU/FPN Calibration Process as “pixel Overflow” or “Pixel Underflow” because some pixels have been detected as too high or too low in the source image to be corrected efficiently. The Calculation result will be proposed anyway as it's just a warning message. The Status Register is the changed and displayed in CommCam “Status” section :

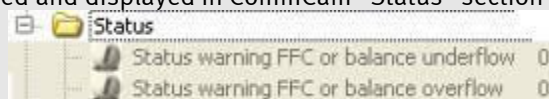

Register status is detailed chap §6.3.1.

6.3.5.3 Manual Flat Field Correction

The FFC Coefficients can also be processed outside of the Camera or changed manually by accessing directly their values in the Camera : This is the “Manual” FFC.

In CommCam, the User can access to a specific interface by clicking on “click for extended control” in both “Manual FFC calibration” and “Manual FPN calibration sections” :



This will allow the user to upload/download out/in the Camera the FFC coefficients in/from a binary or text file that can be processed externally.



It is recommended to setup the baud rate at the maximum value possible (115000 for example) otherwise the transfer can take a long time.

- **FPN coefficients modification** : Direct access to the FPN coefficients for reading or writing.
The FPN coefficients are read packets of x128 coefficients :
 - ⇒ Read function : “**r ffco <addr>**” : Read 128 consecutive FPN user coefficients starting from **<addr>** address. Returned value is in hexadecimal, without space between values (one unsigned short per coefficient).
 - ⇒ Write function :” **w ffco <addr><val>**” : Write 128 consecutive FPN user coefficients starting from the **<addr>** address. **<val>** is the concatenation of individual FPN values, without space between the values (one unsigned short per coefficient).
- **PRNU coefficients modification** : Direct access to the PRNU coefficients for reading or writing.
The PRNU coefficients are read packets of x128 coefficients :
 - ⇒ Read function : “**r ffcg <addr>**” : Read 128 consecutive PRNU user coefficients starting from **<addr>** address. Returned value is in hexadecimal, without space between values (one unsigned short per coefficient).
 - ⇒ Write function :” **w ffcg <addr><val>**” : Write 128 consecutive PRNU user coefficients starting from the **<addr>** address. **<val>** is the concatenation of individual PRNU values, without space between the values (one unsigned short per coefficient).

6.3.5.4 FFC User Bank Management

The new-processed FFC values can be saved or restored in/from 4 x User banks. Both Gains and Offsets in the same time but also the FFC Adjust User target and associated gain. These functions are available in the Flat Field correction/Save & Restore FFC section :

- **Restore FFC from Bank** (*RestoreFFCFromBank*) : Restore the FFC from a Bank in the current FFC.
 - ⇒ Read function : “**r rffc**” : Get the current FFC Bank used
Returned by the camera : 0 for Factory bank or 1 to 8 for User banks
 - ⇒ Write function : “**w rffc <val>**” : Bank <val> 1 to 8 for User banks

Note : Factory means neutral FFC (no correction).

- **Save FFC in User Bank** (*SaveFFCToBank*) : Save current FFC in User Bank
 - ⇒ Can not be read
 - ⇒ Write function : “**w sffc <val>**” : User bank <val> if from 1 to 8.

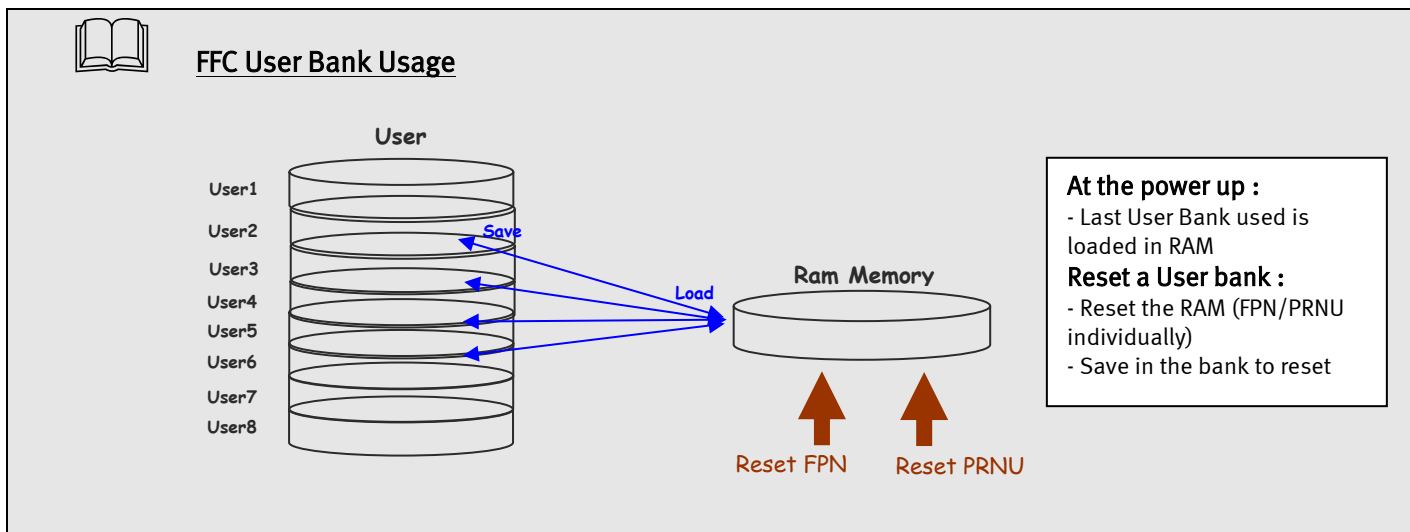

6.3.6 Look Up Table

The User can define an upload a LUT in the Camera that can be used at the end of the processing.

The LUT is defined as a correspondence between each of the 4096 gray levels (in 12 bits) with another outputted value.

For example, a “negative” or “reverse” LUT is the following equivalence :

Real value	Output value
0	4095
1	4094
2	4093
...	...

Then the size of each value is 12bits but the exchanges with the Application/PC are done on 16 bits :

For 4096 gray levels (from 0 to 4095) the total file size for a LUT is 8Ko.

If this LUT is enables, the “Contrast Expansion” feature (digital Gain and Offset) will be disabled

- **LUT Enable (*LUTEnable*)** : Enable the LUT and sizable the Digital Gain / Offset
This function is available in the LUT section :.
 - ⇒ Read function : “**r lute**” : Get the LUT status
Returned by the camera : 0 is LUT disabled, 1 if enabled
 - ⇒ Write function : “**w lute <val>**” : <val> is 0 for disable, 1 for enable
- **Upload / Download the LUT coefficients** : Direct access to the LUT coefficients for reading or writing. In CommCam, the User can access to a specific interface by clicking on “click for extended control” in the LUT section :



- ⇒ Read function : “**r lutc <addr>**” : Read 128 LUT coefficients starting from address <addr> from 0 to 4095-128.
Returned value is the concatenation in hexadecimal of individual LUT values, without space between values. (one unsigned short per coefficient)
 - ⇒ Write function : “**w lutc <addr><val>**” : Write 128 LUT coefficients starting from address <addr> form 0 to 4095-128.
<val> is the concatenation in hexadecimal of individual LUT values, without space between values. (one unsigned short per coefficient)
- **Save & Restore LUT in User Banks** : The LUT loaded in RAM memory can be saved or restored in/from 4 User banks. These functions are available in the LUT/Save & Restore LUT Settings section :
 - **Restore LUT from Bank (*RestoreLUTFromBank*)** : Restore the LUT from a User Bank in the current RAM Memory.
 - ⇒ Read function : “**r rlut**” : Get the current LUT Bank used
Returned by the camera : 1 to 4 for User banks
 - ⇒ Write function : “**w rlut <val>**” : Bank <val> 1 to 4 for User banks
 - **Save LUT in User Bank (*SaveLUTToBank*)** : Save current LUT in User Bank
 - ⇒ Can not de read
 - ⇒ Write function : “**w slut <val>**” : User bank <val> if from 1 to 4.

The bank number <val> is given in (*LUTSetSelector*)

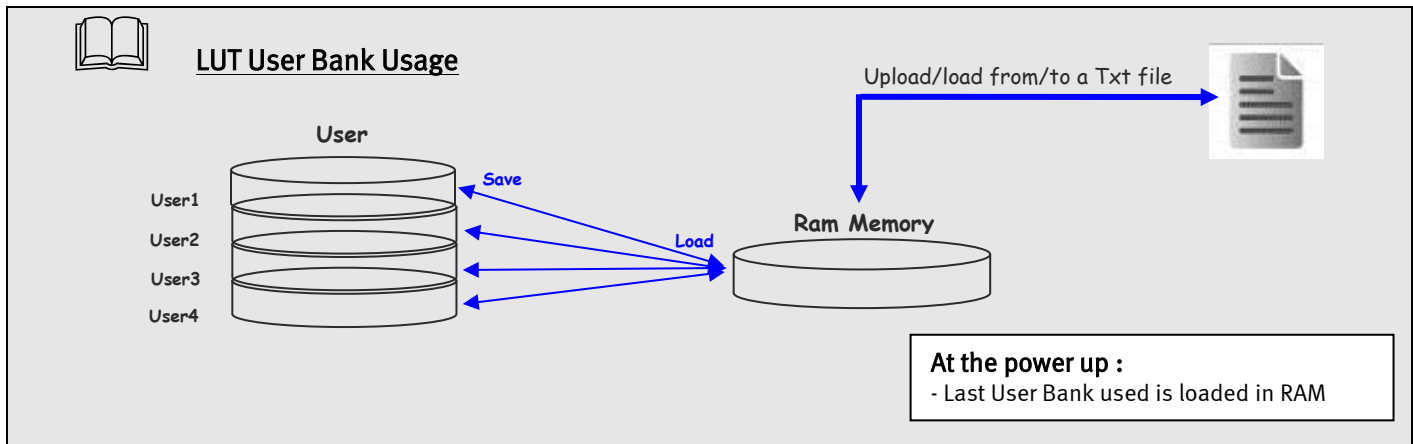

6.3.7 Statistics and Line Profile

This function allows the User to get some statistics on a pre-defined ROI. On request, the Camera acquires and then calculates some key values as the min, the max, the average or the standard deviation in this Region of Interest. The grab and calculation command and also the collection of the results is not performed in real time as it is done through the serial connection.

This function and the results are available in CommCam in the “Line Profile Average” Section :

- **Line Profile average measurement (*LineAverageProfile*)** : Control the grab and computation of the statistics.
 - ⇒ Read function : “**r pixs**” : Get the status of the calculation
 - Returned by the camera : 0 : finished, 1: running
 - ⇒ Write function :
 - “**w pixs 1**” : Start the accumulation and then the computing
 - “**w pixs 0**” : Abort the computing.

The Calculated values are detailed as following :

- **Pixel average Value (*PixelROIMean*)** : Average gray level value calculated on whole Region of interest
 - ⇒ Read function : “**r pavr**” : Get the average value
 - Returned by the camera : Unsigned format value : U12.4
 - **Pixel Standard deviation (*PixelROIStandardDeviation*)** : standard deviation of all the pixel gray level values of Region of interest
 - ⇒ Read function : “**r pstd**” : Get the standard deviation
 - Returned by the camera : Unsigned format value : U12.4
 - **Pixel Min value (*PixelROIMin*)** : Minimum gray level pixel value on the whole region of interest.
 - ⇒ Read function : “**r pmin**” : Get the Minimum value
 - Returned by the camera : Unsigned format value : U12.4
 - **Pixel Max Value (*PixelROIMax*)** : Maximum gray level pixel value on the whole region of interest
 - ⇒ Read function : “**r pmax**” : Get the maximum value
 - Returned by the camera : Unsigned format value : U12.4
- **Pixel access Line number (*PixelAccessLineNumer*)** : Set the number of lines to accumulate.
 - ⇒ Read function : “**r pixl**” : Get the number of line
 - Returned by the camera : 1, 256, 512 or 1024
 - ⇒ Write function : “**w pixl <val>**” : Set the number of lines. <val> is 1, 256, 512 or 1024.
 - **Pixel ROI Start (*PixelRoiStart*)** : Set the Region of Interest start position.
 - ⇒ Read function : “**r prod**” : Get the starting pixel
 - Returned by the camera : value between 0 and 16383
 - ⇒ Write function : “**w prod <val>**” : Set the starting pixel. <val> is between 0 and 16383
 - **Pixel ROI Width (*PixelRoiWidth*)** : Set the Width of the Region of Interest.
 - ⇒ Read function : “**r prow**” : Get the width in pixel
 - Returned by the camera : value between 1 and 16384
 - ⇒ Write function : “**w prow <val>**” : Set the ROI width in pixels. <val> is between 1 and 16384



After performing a line profile measurement, all the values computed which are described below are not refreshed automatically in CommCam : You have to right-click on each value and ask for an individual refresh.

6.3.8 Privilege Level

There are 3 privilege levels for the camera :

- Factory (0) : Reserved for the Factory
- Integrator (1) : Reserved for system integrators
- User (2) : For all Users.

The Cameras are delivered in Integrator mode. They can be locked in User mode and a specific password is required to switch back the Camera in Integrator mode. This password can be generated with a specific tool available from the hotline (hotline-cam@e2v.com)

This function is available in the Privilege section :

- **Privilege level Management** (*PrivilegeLevel*) : Get the current Camera privilege level..
 - ⇒ Read function : “**r lock**” : Get the current privilege
Returned by the camera : 0 to 2
 - ⇒ Write function : “**w lock <val>**” : <val> is as follow
 - **2** : Lock the Camera in Integrator or “privilege User”
 - **<computed value>** : Unlock the Camera back in Integrator mode

6.3.9 Save & Restore Settings

The settings (or Main configuration) of the Camera can be saved in 4 different User banks and one Integrator bank. This setting includes also the FFC and LUT enable

This function is available in the Save & Restore Settings section :

- **Load settings from Bank** : Allows to restore the Camera settings.
 - ⇒ Read function : **"r rcfg"** : Get the current Tap Bank in use
 - ⇒ Write function : **"w rcfg <val>"** : Load settings from bank <val> (0: Factory , 1 to 4 for Users, 5 for Integrator)
- **Save settings to Bank** : Allows to save the Camera settings in User or Integrator Bank
 - ⇒ Write function : **"w scfg <val>"** : Save the current settings in the User bank <val> (1 to 4 for User, 5 for Integrator)



The integrator bank (User Sets5) can be written only if the Camera is set in integrator mode (Privilege level = 1). This integrator bank can be used as a « Factory default » by a system integrator.



Configuration Bank Usage

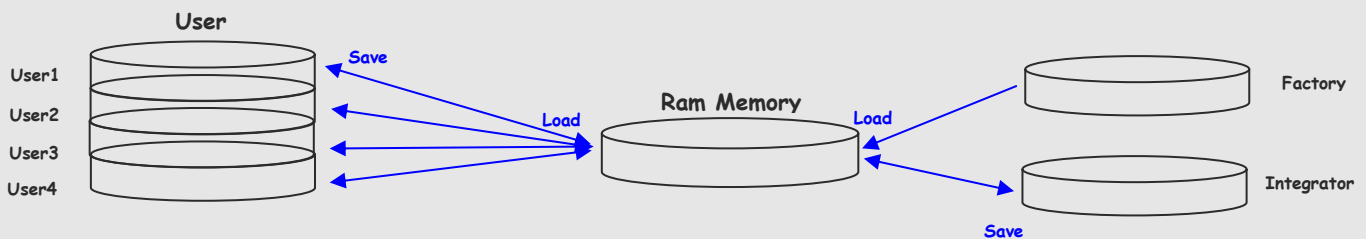

At the power up : Last User Bank used is loaded in RAM
 "Integrator" Bank (5) can be locked by switching the Camera in "User" mode (cf : Privilege feature). Then it can't be saved any more without switching back the Camera in "Integrator" Mode.

7 APPENDIX A: Test Patterns

7.1 Test Pattern 1: Vertical wave

The Test pattern 1 is a vertical moving wave : each new line will increment of 1 gray level in regards with the previous one.

- In 12 bits the level reaches 4095 before switching down to 0
- In 8 bits the level reaches 255 before switching down to 0

7.2 Test Pattern 2: Fixed Horizontal Ramps

7.2.1 In 8 bits (Full) format

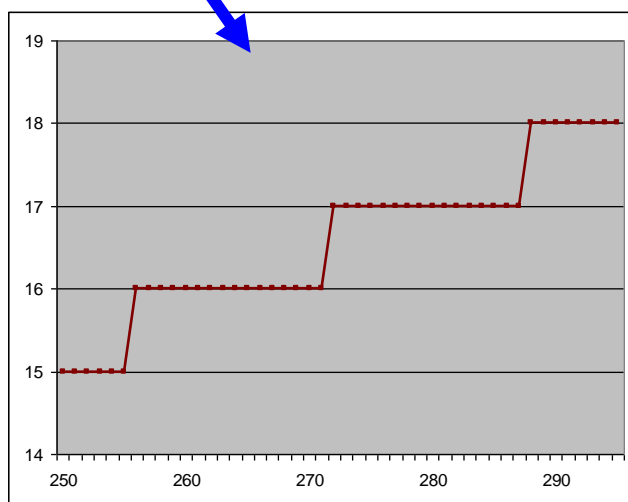
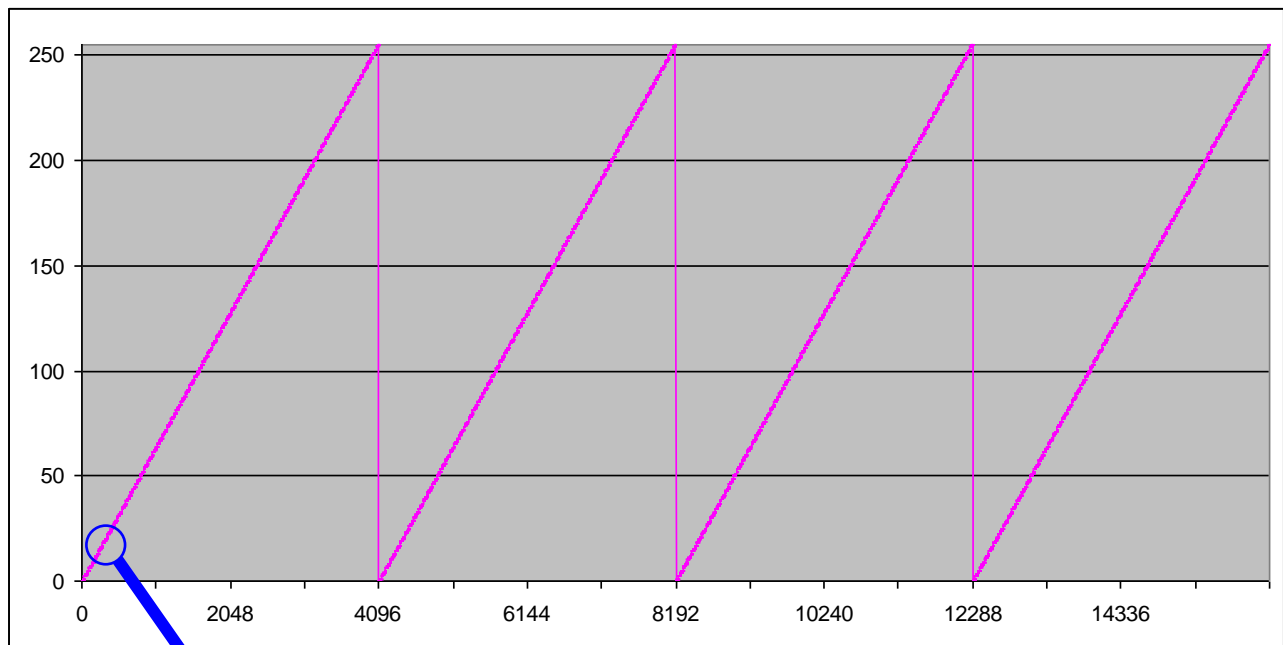

An increment of 1 LSB is made every 16 pixels
When it reaches 255, turns back to 0 and starts again

7.2.2 In 12 bits (Medium) format

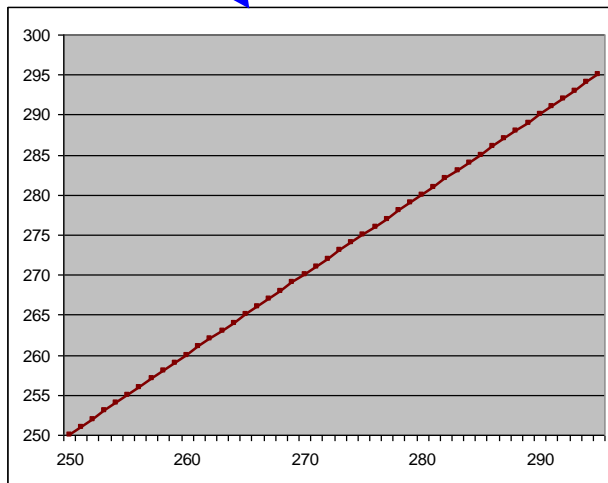
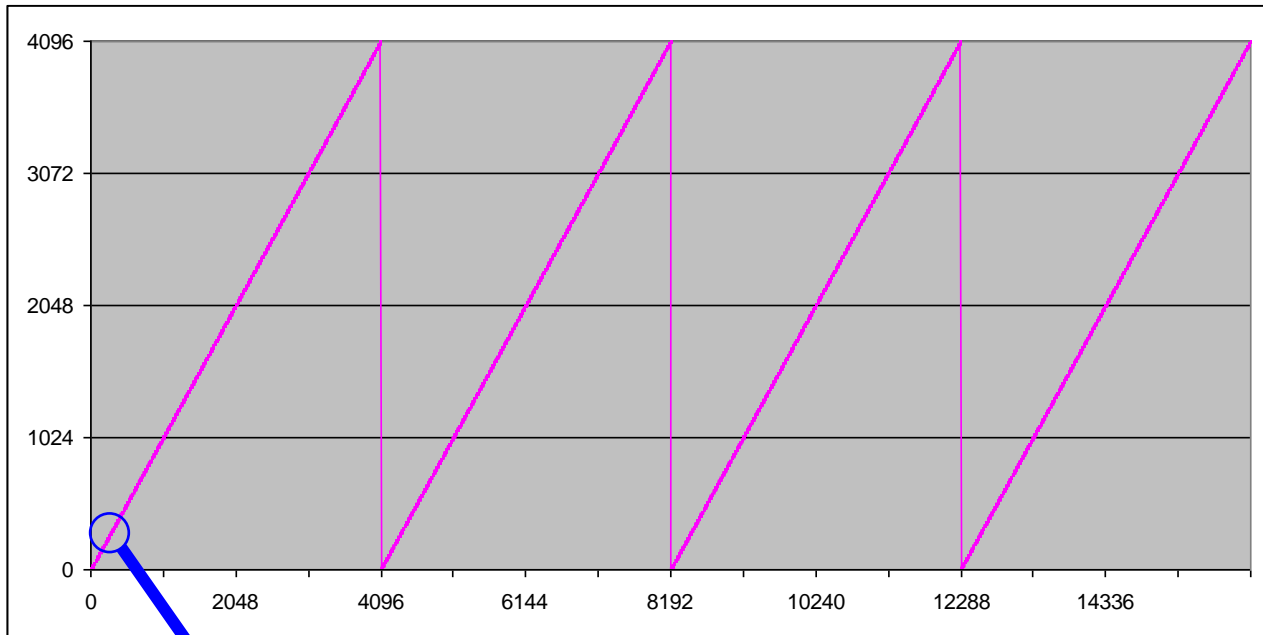

An increment of 1 LSB is made for each pixel. When it reaches 4095, turns back to 0 and starts again

8 APPENDIX B: Timing Diagrams

8.1 Synchronization Modes with Variable Exposure Time

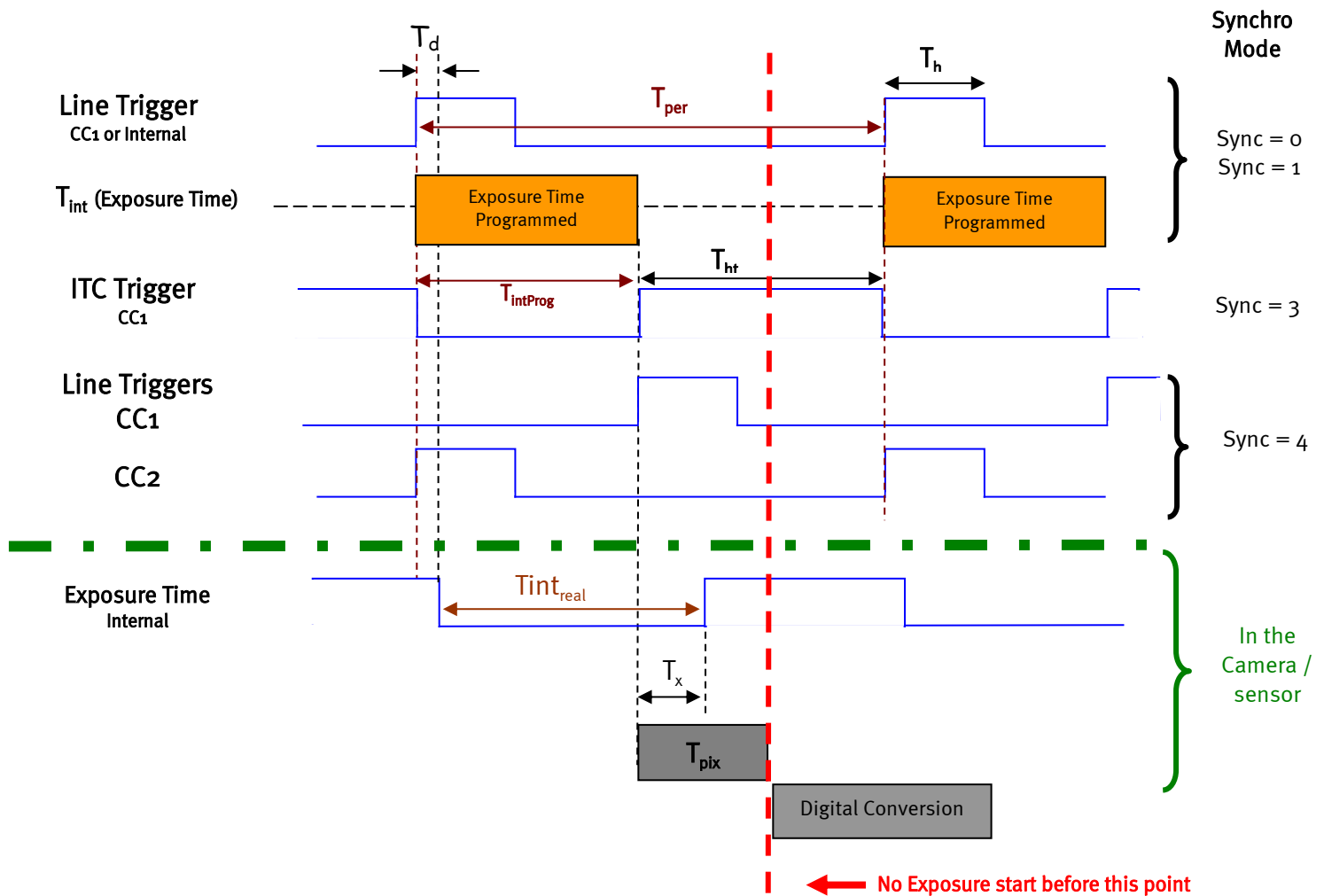

T_{pix} : Timing Pixel. During this uncompressible period, the pixel and its black reference are read out to the Digital converter. During the first half of this timing pixel (read out of the black reference), we can consider that the exposure is still active.

Digital Conversion : During the conversion, the analog Gain is applied by the gradient of the counting ramp (see next chapter : Gain & Offset). The conversion time depends on the pixel format :

- 8 or 10 bits : **6 μ s**
- 12 bits : **24 μ s**

This conversion is done in masked time, eventually during the next exposure period.

T_d : Delay between the Start exposure required and the real start of the exposure.



If T_{per} is the Line Period (internal or external coming from the Trigger line), in order to respect this line Period, the Exposure Time as to be set by respecting : $T_{int} + T_{dix} \leq T_{der}$
 Then, the real exposure time is : $T_{int_{real}} = T_{int} + T_x - T_d$
 In the same way, The high level period of the Trig signal in sync=3 mode, $T_{ht} \geq T_{dix}$

For a Line Period of $LinePer$, the maximum exposure time possible without reduction of line rate is : $T_{int_{max}} = T_{der} - T_{dix}$ (T_{dix} is defined above) but the effective Exposure Time will be about $T_{int_{real}} = T_{int} + T_x - T_d$.

8.2 Synchronisation Modes with Maximum Exposure Time

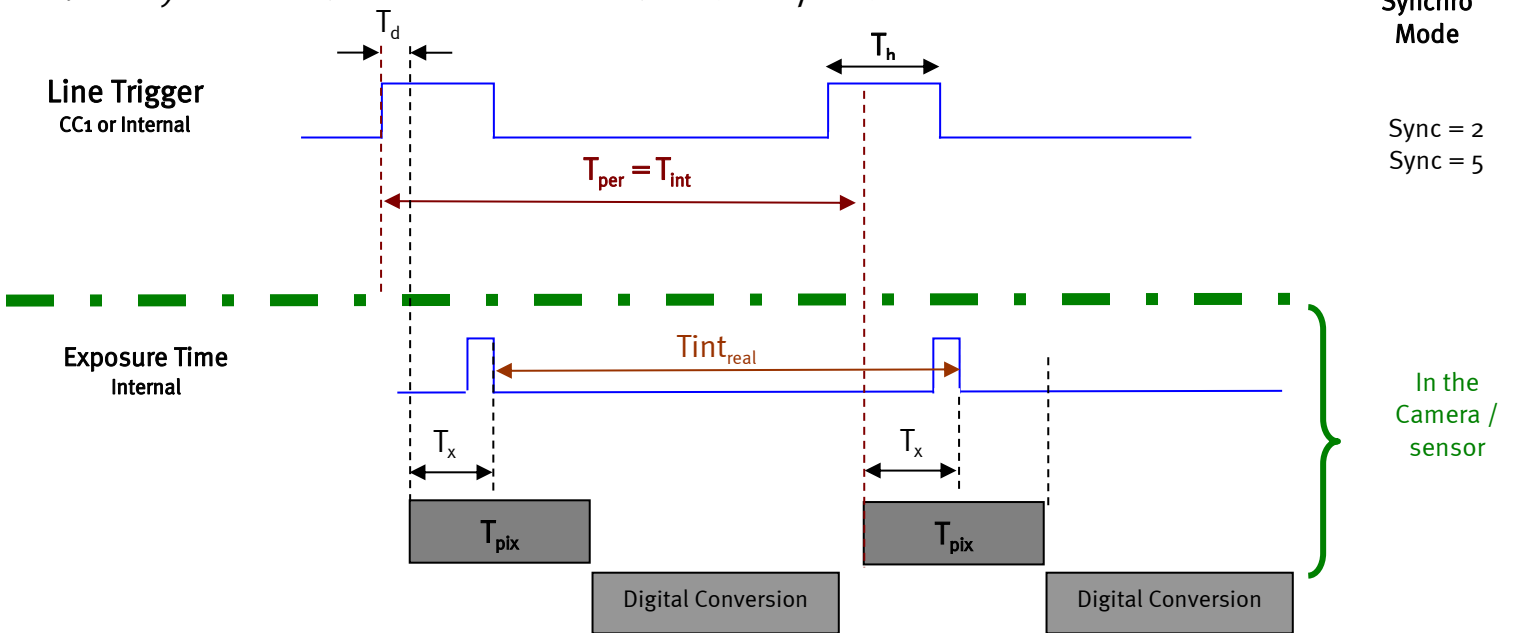

In these modes, the rising edge of the Trigger (internal or External) starts the readout process (T_{pix}) of the previous integration. The Real exposure time ($T_{int_{real}}$) is finally equal to the Line Period (T_{per}) even if it's delayed from ($T_x + T_d$) from the rising edge of the incoming Line Trigger.

8.3 Timing Values

Label	Min	Unit
T_{pix}	5	μs
T_x	3,1	μs
T_h	0,120	μs
T_{ht}	T_{pix}	μsec
T_d	1.1	μs

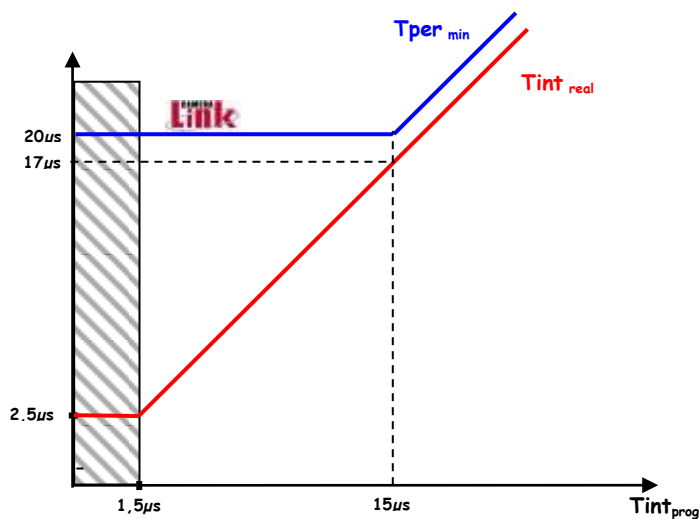

9 APPENDIX C: CameraLink Data Cables

You may check the compliance of your CameraLink cables with the transportation of the 85MHz data rate. The main parameter to be checked in the cable specification is the skew (in picoseconds) This parameter is given for a dedicated maximum value per meter of cable (as max : 50ps/m)

The CameraLink Standards defines the maximum total skew possible for each data rate :

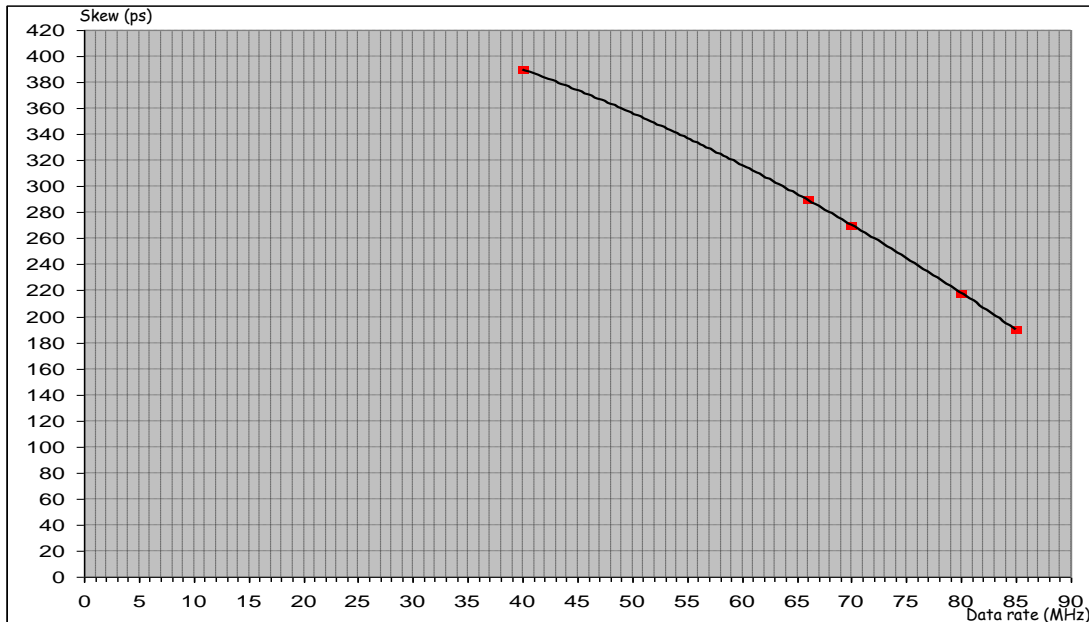

Here is a following example of cable and the cable length limitation in accordance with the standard :

Conductor Size:	28 AWG Stranded
Propogation Velocity:	1.25 ns/ft [4.1 ns/m]
Skew (within pair):	50 ps/meter maximum
Skew (channel skew per chipset):	50 ps/meter maximum

<u>DataRate</u>	<u>Skew</u>	<u>Cable Length</u>
40Mhz	390ps	7,8m
66MHz	290ps	5,8m
70MHz	270ps	5,4m
80MHz	218ps	4,36m
85MHz	190ps	3,8m



Starting with the firmware version 2.0.4B, the camera has been improved in term data output quality in order to push back the limitation and allow about 5m of length on some good cables (even specified at 50ps/m).

10 APPENDIX D: Lenses Compatibility

QIOPTICS (LINOS)				
	Nominal Magnification	Magnification Range	M95 Focus tube Reference	Lens Reference Part number
Inspec.x. L 5.6/105	0,33 X	0,25 – 0,45 X	2408-012-000-41	0703-085-000-20
Inspec.x. L 5.6/105	0,5 X	0,4 – 0,65 X	2408-012-000-41	0703-084-000-20
Inspec.x. L 5.6/105	0,87 X	0,6 – 0,9 X	2408-012-000-43	0703-083-000-20
Inspec.x. L 5.6/105	1 X	0,85 – 1,2 X	2408-012-000-43	0703-082-000-20
Inspec.x. L 4/105	3 X	2,8 – 3,3 X	2408-012-000-46	0703-104-000-20
Inspec.x. L 4/105	3,5 X	3,3 – 3,7 X	2408-012-000-44	0703-095-000-21
Inspec.x. L 3.5/105	5 X	4,8 – 5,2 X	2408-012-000-45	0703-102-000-20
SCHNEIDER KREUZNACH				
	Nominal Magnification	Magnification Range	Working Distance (at nom. Mag.)	Reference Part number
SR 5.6/120-0058	1 X	0,88 – 1,13 X	212 mm	1002647
SR 5.6/120-0059	0,75 X	0,63 – 0,88 X	252 mm	1002648
SR 5.6/120-0060	0,5 X	0,38 – 0,63 X	333 mm	1002650
SR 5.6/120-0061	0,33 X	0,26 – 0,38 X	453 mm	1004611
Accessories	V mount 25mm macro-extension tube		Necessary to combine the whole lens system	20179
	V mount to Leica adapter			20054
	Unifoc 76			13048
	Adapter M58x0.75 – M95x1			1062891
	Extension tube M95x1, 25mm		To be combined to reach the appropriate magnification	1062892
	Extension tube M95x1, 50mm			1062893
	Extension tube M95x1, 100mm			1062894
MYUTRON				
	Nominal Magnification	Working Distance	M95 Custom Mount available Aperture (∞) : 4.7	
XLS03-E	x0,3	477mm		
XLS53-E	x0,5	324mm		
XLS75-E	x0,75	246mm		
XLS010-E	x1	197mm		
XLS014-E	x1,4	170mm		
XLS203-E	x2	146mm		

EDMUND OPTICS			
	Nominal Magnification	Working Distance (at nom. Mag.)	Reference Part number
TechSpec F4	1 X	151 mm	NT68-222
TechSpec F4	1,33 X	158,5 mm	NT68-223
TechSpec F4	2,0 X	129 mm	NT68-224
TechSpec F4	3,0 X	110 mm	NT68-225
Accessories	Large Format Tip/Tilt Bolt Pattern Adapter, 2X		NT69-235
	Large Format Focusing Module		NT69-240
	Large Format Adapter Set		NT69-241
NAVITAR			
Raptar Pro 4/86	1 X	Extension Tubes on request	1 - 17494
NIKON			
Rayfact F4	0,05 X – 0,5 X	1820,4mm – 230,3mm	Rayfact ML90mm F4

11 APPENDIX E: TROUBLESHOOTING

11.1 Camera

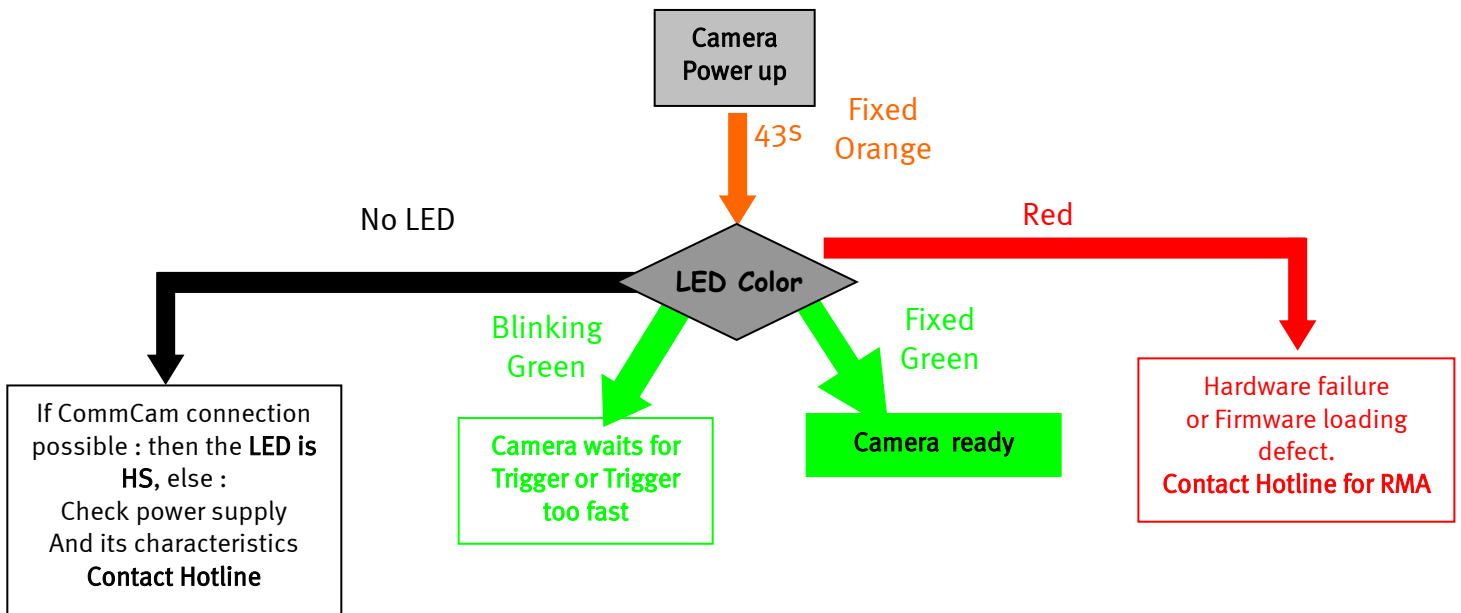

11.2 CommCam Connection

Refer to CommCam software Help for the connection issues.

12 APPENDIX F: Command Summary Tables

12.1 Device Control

Feature	CL Command	Description
DeviceVendorName	r vdnm	Get camera vendor name as a string (32 bytes long including '\0')
DeviceModelName	r mdnm	Get camera model name as a string (32 bytes long including '\0')
DeviceFirmwareVersion	r dfvw	Get camera synthetic firmware version (PKG version) as a string (32 bytes long including '\0')
DeviceVersion	r dhvw	Get camera version as a string (hardware version) (32 bytes long including '\0')
DeviceManufacturerInfo	r idnb	Get camera ID as a string (48 bytes long including '\0')
DeviceUserID	r cust	Get device user identifier as a string (16 bytes long including '\0')
	w cust <idstr>	Set camera identifier to <idstr>
DeviceID	r deid	Read Serial Nb
ElectronicBoardID	r boid	Read Electronic Board ID
DeviceSFNCVersionMajor	Xml Virtual	
DeviceSFNCVersionMinor	Xml Virtual	
DeviceSFNCVersionSubMinor	Xml Virtual	

12.2 Image Format

Feature	Command	Description
SensorWidth	r sns w	Get sensor physical width.
SensorHeight	Xml virtual	
WidthMax	Map on SensorWidth	
HeightMax	Xml virtual	
Height	Xml virtual	
Width	Xml virtual	Depends on (OuputRegion, OuputRegionWidth) and SensorWidth
ReverseReading	r revr	Get reverse reading value
	w revr 0	Set reverse reading to "disable"
	w revr 1	Set reverse reading to "enable"
OutputMode	r mode	Get output mode (CameraLink configuration and CMOS sensor resolution)
	w mode 0	Set output mode to "Medium4Outputs8bits"
	w mode 1	Set output mode to "Medium4Outputs12bits"
	w mode 2	Set output mode to "Full8Outputs8bits"
	w mode 3	Set output mode to "FullPlus10Outputs8bits"
OutputFrequency	r clfq	Get Camera Link frequency
TestImageSelector	r srce	Get test (output FPGA) image pattern
	w srce 0	Set test (output FPGA) image pattern to "Off", processing chaine activated
	w srce 1	Set test (output FPGA) image pattern to "GreyHorizontalRamp", processing chaine deactivated
	w srce 2	Set test (output FPGA) image pattern to "White pattern", processing chaine deactivated
	w srce 3	Set test (output FPGA) image pattern to "gray pattern", processing chaine deactivated
	w srce 4	Set test (output FPGA) image pattern to "Black pattern", processing chaine deactivated
	w srce 5	Set test (output FPGA) image pattern to "GreyVerticalRampMoving", processing chaine deactivated

12.3 Synchro and Acquisition

Feature	Commands	Description
LinePeriod	r tper	Get current line period
	w tper <val>	Set line period, from from 1 (0,1µs) to 65535 (6553,5µs), step 1 (0,1µs)
LinePeriodMin	r tpmi	Get current line period min (0..65535 step 0,1µs)
AcquisitionLineRate	Xml Virtual	= 1 / LinePeriod en Hertz
ExposureTimeAbs	r tint	Get exposure time
	w tint <val>	Set exposure time, from 1 (0,1µs) to 65535 (6553,5µs), step 1 (0,1µs)
TriggerPreset	r sync	Get trigger preset mode
	w sync 0	Set trigger preset mode to Free run timed mode, with exposure time and line period programmable
	w sync 1	Set trigger preset mode to Triggered mode with exposure time settings
	w sync 2	Set trigger preset mode to Triggered mode with maximum exposure time
	w sync 3	Set trigger preset mode to Triggered mode with exposure time controlled by one signal
	w sync 4	Set trigger preset mode to Triggered mode with exposure time controlled by two signals
	w sync 5	Set trigger preset mode to Free run mode, with max exposure time and programmable line period

12.4 Gain & Offset

Feature	Commands	Description
GainAbs GainSelector= AnalogAll	r pamp	Get the current pre-amp gain
	w pamp <val>	Set pre amplifier gain to: 0 (-12dB), 1 (-6dB), 2 (0dB) (analog gain) Change balances and compensation
GainAbs GainSelector= gainAll	r gain	Get current digital gain
	w gain <val>	Set gain from 0dB(0) to +8 dB (6193)
Gain Abs GainSelector=DigitalAll	r gdig	Get contrast expansion digital gain
	w gdig <val>	Set contrast expansion digital gain from 0 (0 dB) to 255 (+14 dB), step 1 (TBD dB)
BlackLevelRaw BlackLevelSelector=All	r offs	Get common black level.
	w offs <val>	Set common black from -4096 to 4095, step 1
GainAbs GainSelector=DigitalTap<j>	r fga<j> <val>	Get tap<j> digital gain. Dynamically updated on AnalogAll gain changes
	w fga<j> <val>	Set tap<j> digital gain from -128 to 127 by step 1 (0.0021dB). Dynamically updated on AnalogAll gain changes
ROI Gain Set	r roig	Read the last ROI gain set
	w roig <val>	Set the Value for the ROI Gain : <val> from 0 to 2047 : U1.11 (1+coeff/1024) => x1..x1.999877 step 1/1024
ROI Set	r rois	Read the last ROI set
	w rois <val>	Set the ROI and applies the ROI Gain on it. <val> is a combination of Start and Stop Addresses for ROI. - Start Address : From 0 to 16382 (0x0000 to 0x3FFE) - Stop Address : From 1 to 16383 (0x0001 to 0x3FFF)

12.5 Flat Field Correction

Feature	Commands	Description
FFCEnable	r ffc	Get Flat Field Correction processing status
	w ffc 0	Disable Flat Field Correction ("False")
	w ffc 1	Enable Flat Field Correction ("True")
FPNReset	w rst 0	Reset FPN coefficients
PRNUReset	w rstg 0	Reset PRNU coefficients
No direct feature	r ffc <addr>	Read 128 Fpn coefficients starting from address <addr>. Return value is in hexadecimal, without space between values (one unsigned short per coef). Format: S9.1 => -256..+255,5 step 1/2
	w ffc <addr> <val>	Write 128 Fpn coefficients (straight to FPGA) starting from address <addr>. <val> is the concatenation of individual Fpnvalue, without space between values.
No direct feature	r ffcg <addr>	Read 128 Prnu coefficients (straight from FPGA) starting from address <addr>. Return value is in hexadecimal, without space between values. Coeff from 0 to 4095 : U2.12 (1+coeff/1024) => x1..x4.999877 step 1/1024
	w ffcg <addr> <val>	Write 128 Prnu coefficients (straight to FPGA) starting from address <addr>. <val> is the concatenation of individual PRNUvalue, without space between values.
FFCCalibrationCtrl	r calg	Get the PRNU calibration status
	w calg 0	Abort PRNU calibration by setting it to "Off" (no effect if already stopped)
	w calg 1	Launch PRNU calibration by setting it to "Once" (no effect if already launched)
PnuCalibrationCtrl	r calo	Get the fpn calibration status
	w calo 0	Abort fpn calibration by setting it to "Off" (no effect if already stopped)
	w calo 1	Launch fpn calibration by setting it to "Once" (no effect if already launched)
FFCAdjust	r ffad	Get ffc adjust state
	w ffad 0	Disable ffc adjust
	w ffad 1	Enable ffc adjust
FFCAutoTargetLevel	r tfad	Get the FFC target adjust level
	w tfad <val>	Set FFC target adjust level, from 0 to 4095, step 1
LowFrequencyFilterWidth	r lffw	Configure windows (width) around the pixel (+/- val) for the average filter o : filter is disable 1-255 : nb pixels around the pixel to filter. Interval : [-nb to +nb]
	w lffw <val>	

12.6 LUT

Feature	Commands	Description
LUTEnable	r lute	Get LUT status
	w lute 0	Disable LUT ("False")
	w lute 1	Enable LUT ("True")
No direct feature	r lutc <addr>	Read 128 LUT coefficients starting from address <addr> from 0 to 4095-128. Return value is in hexadecimal, without space between values. (one unsigned char per coef)
	w lutc <addr> <val>	Write 128 LUT coefficients starting from address <addr> from 0 to 4095-128. <val> is the concatenation of individual LUTvalue, without space between values.

12.7 Save and Restore

Feature	Commands	Description
UserSetLoad	r rcfg	Get the current user configuration bank (saved or restored)
	w rcfg <val>	Restore current UserSet from UserSet bank number <val>, from 0 to 5; <val> comes from UserSetSelector.
UserSetSave	w scfg <val>	Save current UserSet to UserSet bank number <val>, from 1 to 5; <val> comes from UserSetSelector. 0 cannot be saved. 5 (Integrator) can't be saved in User mode
UserSetControl	Xml virtual	
RestoreLUTFromBank	r rlut	Get the current LUT bank (saved or restore)
	w rlut <val>	Restore current LUT from LUT bank number <val>, from 1 to 4; <val> comes from LUTSetSelector.
SaveLUTToBank	w slut <val>	Save current LUT to LUT FFC bank number <val>, from 1 to 4; <val> comes from LUTSetSelector.
RestoreFFCFromBank	r rffc	Get the current FFC bank (save or restore)
	w rffc <val>	Restore current FFC (including FPN and FFCGain) from FFC bank number <val>, from 1 to 8; <val> comes from UserFFCSelector (XML feature).
SaveFFCToBank	w sffc <val>	Save current FFC (including FPN and FFCGain) to FFC bank number <val>, from 1 to 8; <val> comes from FFCSelector (XML feature).

12.8 Camera Status

Feature	Commands	Description
PrivilegeLevel	r lock	Get camera running privilege level 0 = Privilege Factory 1 = Privilege Advanced User 2 = Privilege User
ChangePrivilegeLevel	w lock 1	Lock camera privilege to "Advanced User"
	w lock 2	Lock camera privilege to "User"
	w lock <val>	Unlock camera privilege depending on <val> (min=256; max=2 ³² -1)
DeviceTemperature	r temp	Read Mainboard internal temperature (format signed Q10.2 = signed 8 bits, plus 2 bits below comma. Value from -512 to +511) in °C
DeviceTemperatureSelector	Xml Virtual	
Standby	r stby	Read Standby state (CMOS sensor)
	w stby 0	Disable standby mode ("False")
	w stby 1	Enable standby mode ("True"), no more video available but save power and temperature
	r stat	Get camera status (see below for details)
StatusWaitForTrigger		Bit 0: true if camera waits for a trigger during more than 1s
Status trigger too fast		Bit 1: true if camera trigger is too fast
StatusWarningOverflow		Bit 8: true if an overflow occurs during FFC calibration or Tap balance (available only for integrator/user mode)
StatusWarningUnderflow		Bit 9: true if an underflow occurs during FFC calibration or Tap balance (available only for integrator/user mode)
Cc3 Scrolling direction		Bit 11: 0 : forward, 1: reverse
StatusErrorHardware		Bit 16 : true if hardware error detected

12.9 communication

Feature	Commands	Description
ComBaudRate	r baud	Get current baud rate (This feature is not saved in camera)
	w baud 1	Set baud rate to "9600Bds"
	w baud 2	Set baud rate to "19200Bds"
	w baud 6	Set baud rate to "57600Bds"
	w baud 12	Set baud rate to "115200Bds"

12.10 Line Profile Average

Feature	Commands	Description
LineAverageProfile	r pixs	Get the line Line Average Profile status - 1 : running - 0 : finished
	w pixs 0	Abort the Line Average Profile
	w pixs 1	Run the Line Average Profile
PixelAccessLineNumer	r pixl	Get the number of line for average
	w pixl <val>	Set the number of line to accumulate - <val> : 1,256,512,1024
No direct feature	r pixv <add>	Read 128 pixel values starting from address <add>, from SensorWidth-128-1. Return value is in hexadecimal, without space between values. (one unsigned short per coef)
PixelRoiStart	r prod	Get Roi start
	w prod <val>	Set Roi start for pixel statistic computing (0 to SensorWidth -1-1)
PixelRoiWidth	r prow	Get Roi width
	w prow <val>	Set Roi width for pixel statistic computing (1 to SensorWidth)
PixelROI Mean	r pavr	Get ROI Mean (format U12.4)
PixelROI StandardDeviation	r pstd	Get ROI Stand deviation (format U12.4)
PixelROI Min	r pmin	Get ROI Min (format U12.4)
PixelROI Max	r pmax	Get ROI Max (format U12.4)

13 APPENDIX G: Revision History

Manual Revision	Comments / Details	Firmware version	1 st CommCam compliant Version
Rev A	First release	1.0.0	2.2.2
Rev B	Changing Documentation Template FFC Low Band Filter and 8 FFC Memory Banks	1.2.0	2.3.3
Rev C	AVIIVA+ 16k change in UNIIQA+ 16k	1.2.0	2.4.0

Contact us online at:
e2v.com/imaging

