

SkiaGraph X-Ray Camera

DATASHEET



Key Features

- Superior resolution and image quality at 2000 x 2048 pixels
- Scalable active image area of up to 20 x 25 cm
- Supports x-ray energies up to 160 kVp
- Fiber optic technology increases lifetime and improves DQE
- LVDS camera interface easily integrates with image acquisition hardware
- Diverse range of frame grabber options, including Ethernet
- Ready-to-run software and drivers

Overview

The SkiaGraph™ line of CMOS x-ray imaging cameras were specifically designed to exceed the rigorous imaging requirements for a wide variety of medical and industrial radiography applications.

Each camera leverages Rad-Icon's field-proven imaging technology, and combines a large field of view with low cost of ownership to deliver exceptional value to end users. With our state-of-the-art CMOS x-ray cameras, end users can accommodate any general radiography procedure within fixed or portable systems. The SkiaGraph product line is based on our Very Large Area (VLA) sensor technology that delivers superior image quality, high resolution, and an active area of up to 20 x 25 cm. In addition, our cameras are highly cost effective, which enables end users to easily upgrade their existing equipment.

Rad-Icon has extensive experience in medical and industrial imaging with more than 10 years of addressing customers' needs in digital x-ray applications. The company offers OEMs comprehensive consultations and direct access to technologists who have in-depth knowledge of custom application integration. Our technical experts are available to provide customized solutions for various applications, such as General Radiography, Veterinary Diagnostics, Tissue Biopsy, Bone Densitometry, Non-Destructive Testing, and Industrial Imaging.



Description

The SkiaGraph product line leverages CMOS image sensing technology which enables the delivery of lower-dose x-ray images yielding higher image quality than a-Si flat panels and image intensified devices. SkiaGraph features include: (1) superior resolution of over four million pixels at 5 lp/mm; (2) scalable active area up to 20 x 25 cm leveraging our Very Large Area (VLA) sensor technology; (3) a two centimeter border between the active matrix and the edge of the panel, minimizing image obstructions; (4) multiple scintillator options including Kodak Min-R 2190, Kasei DRZ-Std, and custom rare-earth screens; (5) integrated fiber optic technology increases sensor lifetime and improves DQE; and (6) easy integration with camera interface options such as LVDS, USB or Ethernet and software options such as Windows-compatible drivers and application software.

SkiaGraph cameras build upon a tiled configuration of Rad-Icon's RadEye100 image sensors to achieve an active sensing area of 8" x 8" (20 x 20 cm) and larger. The cameras feature low power consumption, high resolution, excellent DQE, and the same flexible readout modes and ease of integration as their predecessors, the Shad-o-Box x-ray camera product line. The SkiaGraph cameras are capable of real-time imaging at up to 1.4 fps (5.2 fps in binned mode), 12-bit digital contrast resolution, 5 lp/mm spatial resolution, and feature a choice of scintillators providing impressive sensitivity as high as 500 ADU/mR. A Gd₂O₂S (Gadox) integrated direct-contact scintillator converts x-ray photons into visible light that is sensed by the CMOS photodiodes. A thin graphite cover protects the sensor from accidental damage as well as ambient light. Analog signals from the photodiode sensors are digitized in eight or more parallel A/D channels and then interleaved for maximum transmission across a high-speed parallel digital interface.

SkiaGraph Camera Options

Model	Resolution	Active Area	Notes
SkiaGraph8	2000x2048 pixels	192x197 mm	Standard model for low-dose applications below 50 kVp
SkiaGraph8 EV	2000x2048 pixels	192x197 mm	For applications requiring increased radiation hardness and DQE at up to 160 kVp
SkiaGraph8 PT - Q3 2009	2000x2048 pixels	192x197 mm	Integrated Ethernet interface for portable, laptop-based applications
SkiaGraph10 EV - Q4 2009	2000x2560 pixels	192x246 mm	Standard 8x10" image format for medical & industrial applications

SkiaGraph Camera Specifications

	Minimum	Typical	Maximum	Units
Resolution		2000x2048		pixels
Active Area		192x197		mm
Pixel Spacing		96		µm
Dark Current (23°C) ⁽¹⁾		15		ADU/s ⁽²⁾
Read Noise (rms, at 1 fps)		<1		ADU
Dynamic Range		72		dB
Conversion Gain ⁽³⁾		1400		elec/ADU
Frame Rate	0.05		1.4	fps
Supply Voltage	6.0	6.5	8.0	V
Supply Current			750	mA
Power Dissipation		<5		W
Operating Temperature	0		50	°C
Humidity (non-condensing)	10		80	% R.H.
Dimensions (LxWxH)		244x279x33		mm
Weight		3.5		kg

(1) Dark current doubles approx. every 8°C

(2) ADU = Analog-Digital Unit = 1 LSB (Least Significant Bit)

(3) High-gain option (2x) available

Resolution & Sensitivity

The intrinsic resolution of the detector within the SkiaGraph camera is determined by the pixel size of the sensor. The actual Modulation Transfer Function (MTF) for various scintillator options is shown in the chart on the following page. A thicker phosphor screen will produce more signal, but at the expense of high-frequency contrast. Please refer to our application note AN07 for more information on scintillator performance and tradeoffs.

Scintillator	Typical Sensitivity
Min-R 2190	98 ADU/mR @ 35kVp 105 ADU/mR @ 50kVp
DRZ-Std	214 ADU/mR @ 35kVp 257 ADU/mR @ 50kVp

SkiaGraph Modulation Transfer Function (MTF) Chart

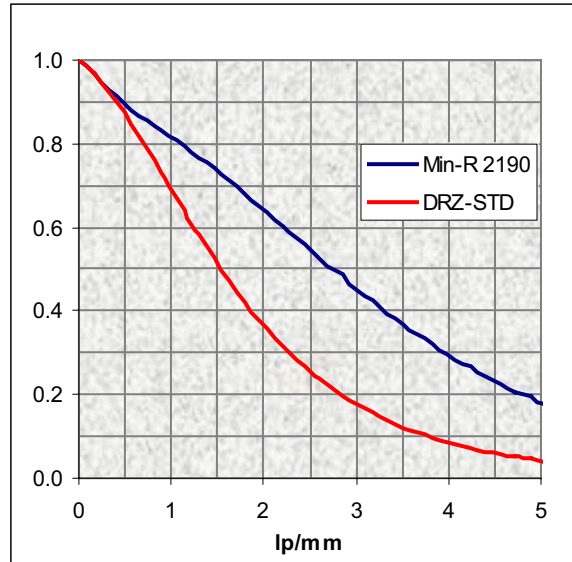

Camera Timing

The camera frame rate can be controlled through the external frame sync inputs on either the parallel interface (EXSYNC) or the separate SMA receptacle. If these inputs are pulled high (SMA not connected) the camera will run continuously at its maximum frame rate of 1.4 fps. To ensure proper synchronization, it is recommended that either one (but not both) of the frame sync inputs be used to control the frame rate. The camera controller will wait for a rising edge on this input before starting the next frame readout.

The digital data on the parallel interface are valid when the pixel clock (PXCLK) is high. To minimize transmission errors, the data should be sampled on its falling edge. The line enable signal (LN_EN) goes high 32 clock cycles before the first valid pixel. It is low for 176 pixel clock cycles during the horizontal blanking interval. It is also low for a minimum of 200 cycles between frames. Frame enable (FR_EN) goes low during the vertical blanking interval to signal the beginning of a new frame. This signal is also available on one of the SMA connectors and can be used to synchronize external events to the camera.

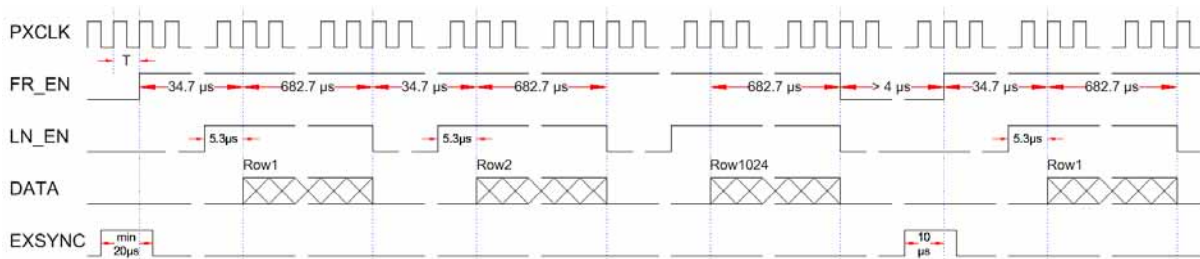

Camera Timing Information

Signal	Parameter	Value	Unit
EXSYNC	min. pulse width	20	μs
	max. pulse width	730 / 190 ⁽¹⁾ / 40 ⁽²⁾	ms
	delay to FR_EN rising edge (typ.)	10	μs
FR_EN	high period (frame active)	734.5 / 192.5 ⁽¹⁾ / 43.7 ⁽²⁾	ms
	low period (EXSYNC high)	4.0	μs
	low period (EXSYNC low)	until next edge on EXSYNC	
	delay to LN_EN rising edge	29.3	μs
LN_EN	high period (line active)	688.0 / 346.7 ⁽¹⁾ / 13.3 ⁽²⁾	μs
	low period (between lines)	29.3	μs
	low period (between frames)	29.3 μs + FR_EN low period	
PXCLK	period (T)	166.7	ns
	duty cycle	50	%

(1) BIN Mode (CTRL1 input low)

(2) SCAN Mode (SC_IN input low)

The binning (CTRL1) and fast scan (SC_IN) control inputs offer additional functionality in the camera. The bin mode (CTRL1 low) causes the readout to skip every other row and column. This shortens the readout time and raises the maximum frame rate of the camera to 5.2 fps. A low level on the SC_IN input puts the camera into a rapid-readout mode in which only the first six pixels of each sensor row are read. In this mode it is possible to scan all rows of the sensor in just 44 ms. This feature can be used to rapidly reset the dark signal prior to an exposure.

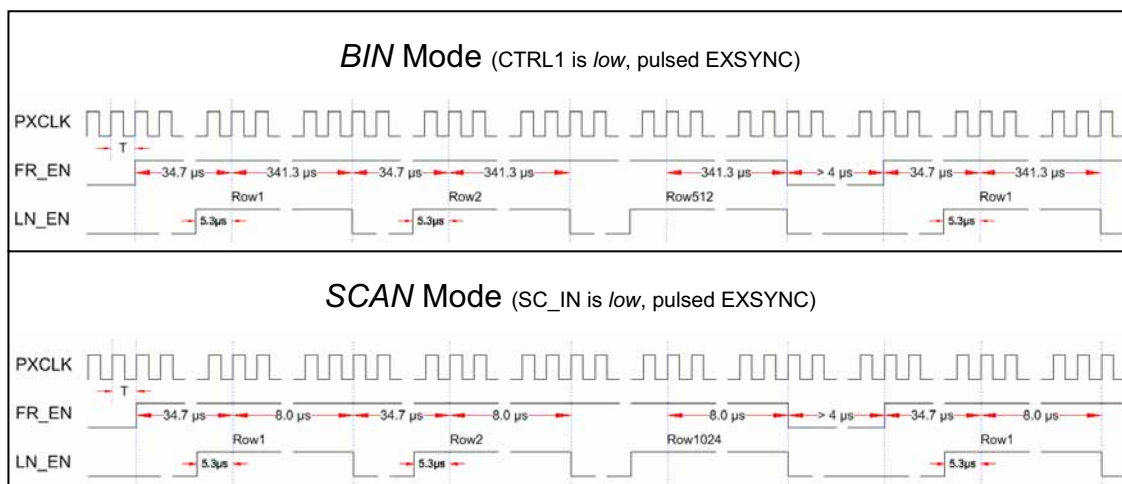

Mechanical Drawings

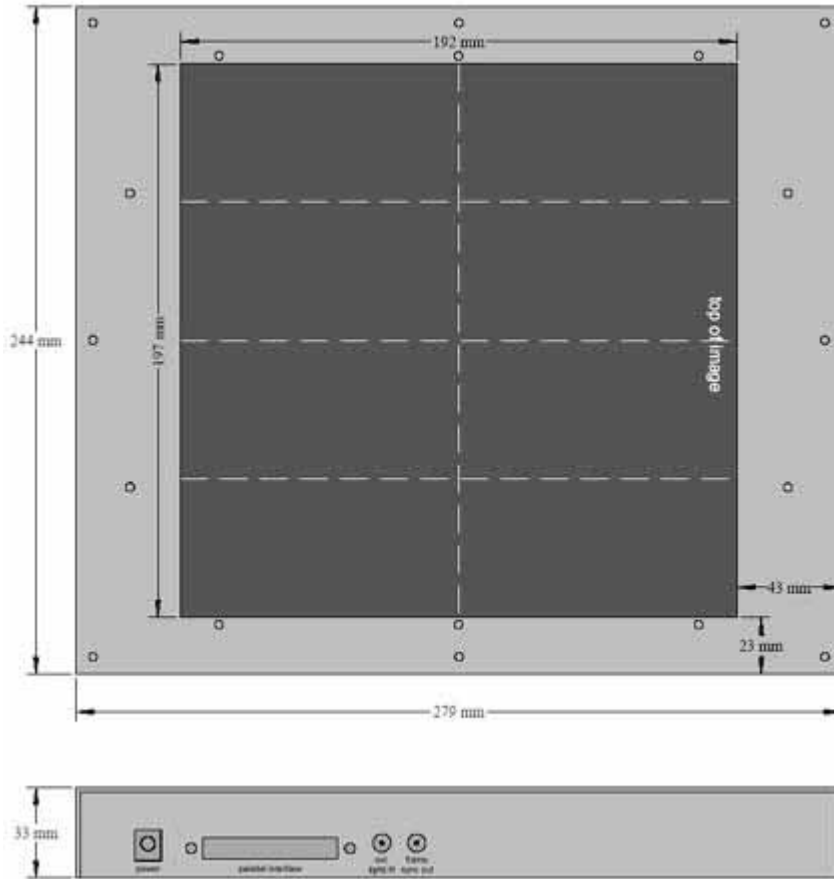

Power Connector

The SkiaGraph camera uses a standard DC power jack with 2.0mm center pin diameter. The matching female plug carries +6.5V on a 2.1mm inside diameter, and the ground return on its 5.5mm outside diameter.

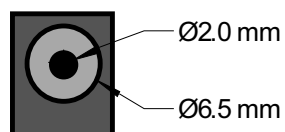

Data Connector

68-pin mini-D (SCSI-3) receptacle

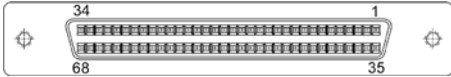

mating connector: AMP 749621-7 (or equivalent)

shell: AMP 786152-3 or 750752-1 (2-56 jackscrews)

Ordering Information

All SkiaGraph cameras are available in a single image quality grade. The default scintillator option is Kodak Min-R 2190 although additional scintillators options such as DRZ-Std are available upon request. Please note that the camera features a digital frame grabber interface, but the frame grabber software and cable are not included. Please contact us for a complete list of options. Cameras ship with a universal input power supply (90-264V, 50-60Hz). For international orders, please specify the type of power cord you require.

Part #	Description	Notes
SK1225	SkiaGraph8 Camera	for the 10-50 kVp energy range
SK1251	SkiaGraph8 EV Camera	for the 10-160 kVp energy range

About Rad-icon

Rad-icon Imaging Corporation is the leading provider of high-performance CMOS image sensors and cameras for the digital radiography market worldwide. Our products enable medical practitioners, industrial manufacturers, and scientific researchers to create superior image quality, high resolution, and large active area images based on our CMOS active pixel sensor (APS) technology. Rad-icon's products address diverse applications such as tissue biopsy, non-destructive testing, circuit board testing, and x-ray crystallography. Our customers are able to implement cost-effective and high-performance digital imaging solutions. Rad-icon Imaging Corporation is a division of DALSA Corporation and based in Santa Clara, CA with integration partners and distributors worldwide. For more information, please visit our website at <http://www.rad-icon.com> or call (408) 486-0886.