

e2v

ELIIXA+ 16k/8k CXP Color
Cmos Multi-Line Color Camera
User Manual



CoaXPress

Summary

1	<i>CAMERA OVERVIEW</i>	5
1.1	Features.....	5
1.2	Key Specifications.....	5
1.3	Description.....	6
1.4	Typical Applications.....	6
2	<i>CAMERA PERFORMANCES</i>	7
2.1	Camera Characterization.....	7
2.2	Image Sensor.....	8
2.2.1	True Colour Mode (TC).....	8
2.2.2	Full Definition Single Mode (FD Single).....	9
2.2.3	Full Definition Enhanced Mode (FD Enhanced).....	9
2.3	Response & QE curves.....	10
2.3.1	Quantum Efficiency.....	10
2.3.2	Spectral Response.....	10
3	<i>CAMERA HARDWARE INTERFACE</i>	11
3.1	Mechanical Drawings.....	11
3.2	Input/output Connectors and LED.....	12
3.2.1	Power Over CoaXPress.....	13
3.2.2	Status LED Behaviour.....	13
3.2.3	Trigger Connector.....	14
4	<i>STANDARD CONFORMITY</i>	15
4.1	CE Conformity.....	15
4.2	FCC Conformity.....	15
4.3	RoHs Conformity.....	15
5	<i>GETTING STARTED</i>	17
5.1	Out of the box.....	17
5.2	Setting up in the system.....	17
6	<i>CAMERA SOFTWARE INTERFACE</i>	18
6.1	Control and Interface.....	18
6.2	Camera Commands.....	19
6.2.1	Device Control.....	19
6.2.2	Image Format.....	21
6.2.2.1	Structure of the Sensor.....	21
6.2.2.2	Forward/Reverse.....	22
6.2.2.3	Test Image Pattern Selector.....	23
6.2.3	Acquisition Control.....	24
6.2.3.1	External Triggers on GPIO Connector.....	25

ELIIXA+® 16k/8k CXP Color

6.2.3.2	CXP Trigger	25
6.2.3.3	Trigger Presets	27
6.2.3.4	Rescaler	28
6.2.4	Digital I/O Control	30
6.2.5	Counters and Timers Control	31
6.2.5.1	Counters	33
6.2.5.2	Timers	33
6.2.6	Gain and Offset	34
6.2.6.1	White Balance	35
6.2.7	Flat Field Correction	36
6.2.7.1	Automatic Calibration	38
6.2.7.2	Manual Flat Field Correction	38
6.2.7.3	Save & Restore FFC	38
6.2.8	Statistics and Line Profile	39
6.2.9	Privilege Level	40
6.2.10	Save & Restore Settings	41
7	APPENDIX A: Test Patterns	42
7.1	Fixed Horizontal Ramps	42
7.2	Color RGBW Fixed Pattern	43
7.3	Vertical wave	43
8	APPENDIX B: Timing Diagrams	44
8.1	Synchronization Modes with Variable Exposure Time	44
8.2	Synchronisation Modes with Maximum Exposure Time	45
8.3	Timing Values	46
9	APPENDIX C: Data Cables	47
10	APPENDIX D: Lenses Compatibility	48
11	Frame Grabbers Compliance	50
12	APPENDIX E: COMMANDS SUMMARY	51
12.1	Category "Device Control"	51
12.2	Image Format	51
12.3	Synchro and Acquisition modes	52
12.4	Scan Direction	53
12.5	GenICam Trigger	53
12.6	Digital IO Control	54
12.7	Counters	55
12.8	Timers	57
12.9	Rescaler	58
12.10	Gain & Offset	58
12.11	Flat Field Correction	59
12.12	Save and restore User Configurations	60

ELIIXA+® 16k/8k CXP Color

12.13	Camera Status.....	60
12.14	Line Profile Average.....	61
13	<i>APPENDIX F: Revision History</i>	62

1 CAMERA OVERVIEW

1.1 Features

- Cmos Colour Sensor :
 - 16384 RGB Pixels, 5 x 5µm (Full Definition)
 - 8192 RGB Pixels 10x10µm (True Colour)
- Interface : CoaXPress® (4x 6Gb/sLinks)
- Line Rate :
 - Up to 47500 l/s In 16k Full Definition Mode
 - Up to 95000 l/s in 8k True Colour Mode
- Bit Depth : 24bits (RGB 8bits)
- Scan Direction
- Flat Field Correction
- Low Power Consumption : <19W
- Compliant with Standard Lenses of the Market



1.2 Key Specifications

Note : All values in LSB is given in 8 bits format

Characteristics	Typical Value	Unit
Sensor Characteristics at Maximum Pixel Rate		
Resolution	16384 or 8192	RGB Pixels
pixel size (square)	5 or 10	µm
Max line rate		
8192 RGB Pixels True Color Mode	95	KHz
16384 RGB Pixels Full Definition Modes	47.5	KHz
Radiometric Performance at Maximum Pixel Rate and minimum camera gain		
Bit depth	3 x 8	Bits
Response (Peak) : True Color or Full Def. Enhanced		
Red	11.8	LSB 8bits/(nJ/cm ²)
Green	11.2	LSB 8bits/(nJ/cm ²)
Blue	7.8	LSB 8bits/(nJ/cm ²)
Response non linearity	< 1	%
PRNU HF Max	3	%
Dynamic range	65	dB

ELIIXA+® 16k/8k CXP Color

Functionality (Programmable via GenICam Control Interface)		
Analog Gain	Up to 12 (x4)	dB
Offset	-4096 to +4096	LSB
Trigger Mode	Timed (Free run) and triggered (Ext Trig, Ext ITC) modes	
Sensor Modes	<ul style="list-style-type: none"> • True Color : 8192 RGB Pixels of 10x10µm • Full Definition Enhanced : 16384 RGB Pixels 5x5µm • Full Definition Single : 16384 RGB Pixels 5x5µm 	
Mechanical and Electrical Interface		
Size (w x h x l)	100 x 156 x 36	mm
Weight	700	g
Lens Mount	M95 x 1	-
Sensor alignment (see chapter 4)	±100	µm
Sensor flatness	±35	µm
Power supply	Power Over CoaXPress : 24	V
Power dissipation - Typ. while grabbing	< 19	W
General Features		
Operating temperature	0 to 55 (front face) or 70 (Internal)	°C
Storage temperature	-40 to 70	°C
Regulatory	CE, FCC and RoHS compliant	

1.3 Description

e2v's next generation of line scan cameras are setting new, high standards for line rate and image quality. Thanks to e2v's recently developed multi-line CMOS technology, the camera provides an unmatched 95,000 lines/s and combines high response with an extremely low noise level; this delivers high signal to noise ratio even when short integration times are required or when illumination is limited. The 5µm pixel size is arranged in four active lines and dual line filter configuration allowing the camera to be operated in several modes: True colour mode with 10µm RGB pixels to provide equivalent colour fidelity to 10µm pixel tri-linear solutions with advanced immunity to web variation or Full definition mode with a unique 16,384 RGB pixel resolution.

1.4 Typical Applications

- Printing Inspection
- High Resolution Document Scanning
- Printed Circuit Board Inspection
- Flat Panel Display Inspection
- High Quality Raw material Surface Inspection



2 CAMERA PERFORMANCES

2.1 Camera Characterization

	Unit	True Color (8k)		Full Definition Single		Full Definition Enhanced	
		Typ.	Max	Typ.	Max	Typ.	Max
Dark Noise RMS	LSB	0.12	1.2	0.11	1.2	0.12	1.2
Dynamic Range	-	2125:1	-	2125:1	-	2125:1	-
RMS Noise (3/4 Sat)	LSB	2.2	-	2.15	4	2.2	4
Full Well Capacity	e ⁻ (per color)	13650	-	13650	-	13650	-
SNR (3/4 Sat)	dB	40	-	40	-	40	-
Peak Response (460/530/660nm)	LSB 8bits/ (nJ/cm ²)	8/10/12	-	4/5/6	-	8/10/12	-
Non Linearity	%	0,3	-	0,3	-	0,3	-
Without Flat Field Correction :							
FPN rms	LSB	0.21	1	0.23	1	0.22	1
FPN pk-pk	LSB	1	2	1	2	1	2
PRNU hf (3/4 Sat)	%	0.13	0,35	0.123	0,35	0.14	0,35
PRNU pk-pk (3/4 Sat)	%	1.1	3	1	3	1.25	3

Test conditions :

- All values are given at Nominal Gain (0dB) : Preamp Gain x1, Amp Gain 0dB
- Figures in LSB are for a 8bits format
- Measured at exposure time = 400μs and line period = 400μs in Ext Trig Mode (Max Exposure Time)
- Maximum data rate

ELIIXA+® 16k/8k CXP Color

2.2 Image Sensor

The Eliixa+ Colour 16k sensor is composed of two pairs of sensitive lines.

The Colour version has been completed with RGB colour Filter and disposed as detailed beside.

Each pair of lines use the same Analog to Digital Column converter (ADC Column). An appropriate (embedded) Time delay in the exposure between each line this allows to combine two successive exposures in order to double the sensitivity of a single line.

This Time Delay Exposure is used only in the Full Definition Enhanced mode (See Below).

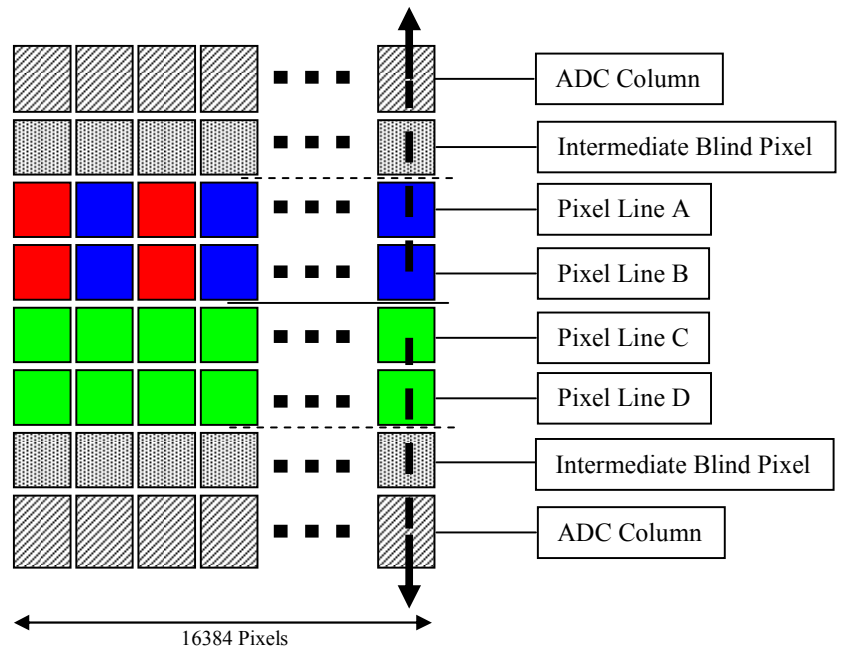

2.2.1 True Colour Mode (TC)

10µm pixels (R,G,B)
Twice less pixels than B/W
Requires x3/2 the data flow of B&W

- Only one (High Sensitivity) TC mode available : Equivalent to 6 x Pixels of 5µm (with their respective colour filters).
- "Full Exposure control" not needed in TC as the TDI is not active (only binning). The Exposure time can be control as for a single line mode.

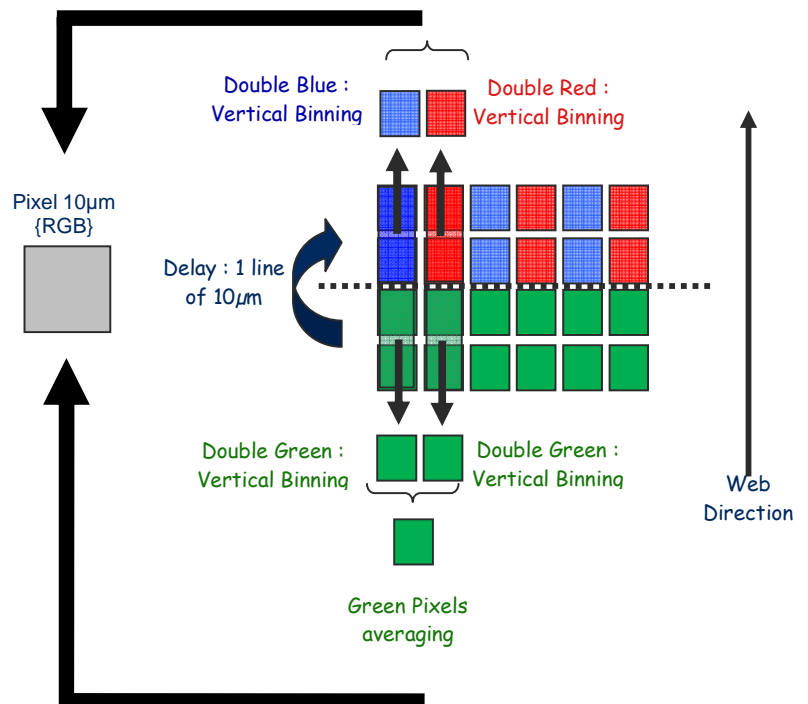

ELIIXA+® 16k/8k CXP Color

2.2.2 Full Definition Single Mode (FD Single)

5µm pixels (R,G,B)
 Same definition than B&W
 Requires x3 the data flow of the B&W

- Sensitivity is half of the TC mode available : Equivalent to 3 x Pixels of 5µm (with their respective colour filters).
- "Full Exposure control" not needed in this mode as the Time Delay Exposure is not active. The Exposure time can be control as for a single line mode.

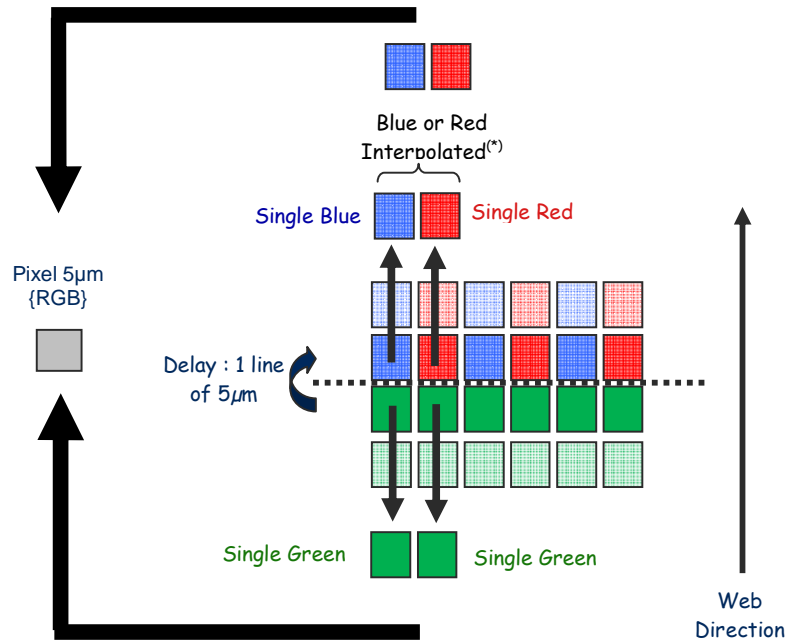

2.2.3 Full Definition Enhanced Mode (FD Enhanced)

5µm pixels (R,G,B)
 Same definition than B&W
 Requires x3 the data flow of the B&W

- Sensitivity is the same as the TC mode available : Equivalent to 6 x Pixels of 5µm (with their respective colour filters).
- "Full Exposure control" is activated in this mode as the Time Delay Exposure is active.

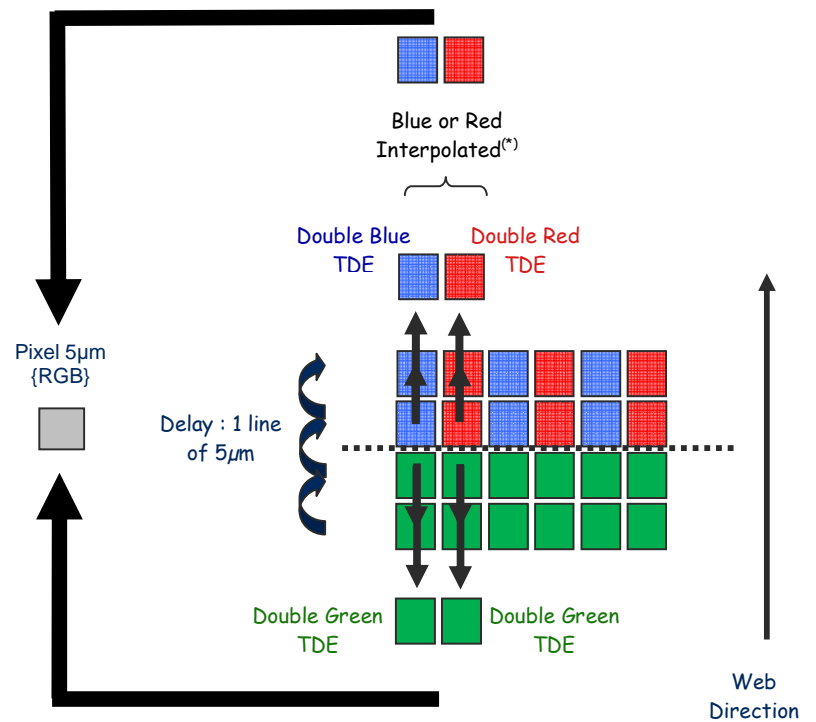

2.3 Response & QE curves

2.3.1 Quantum Efficiency

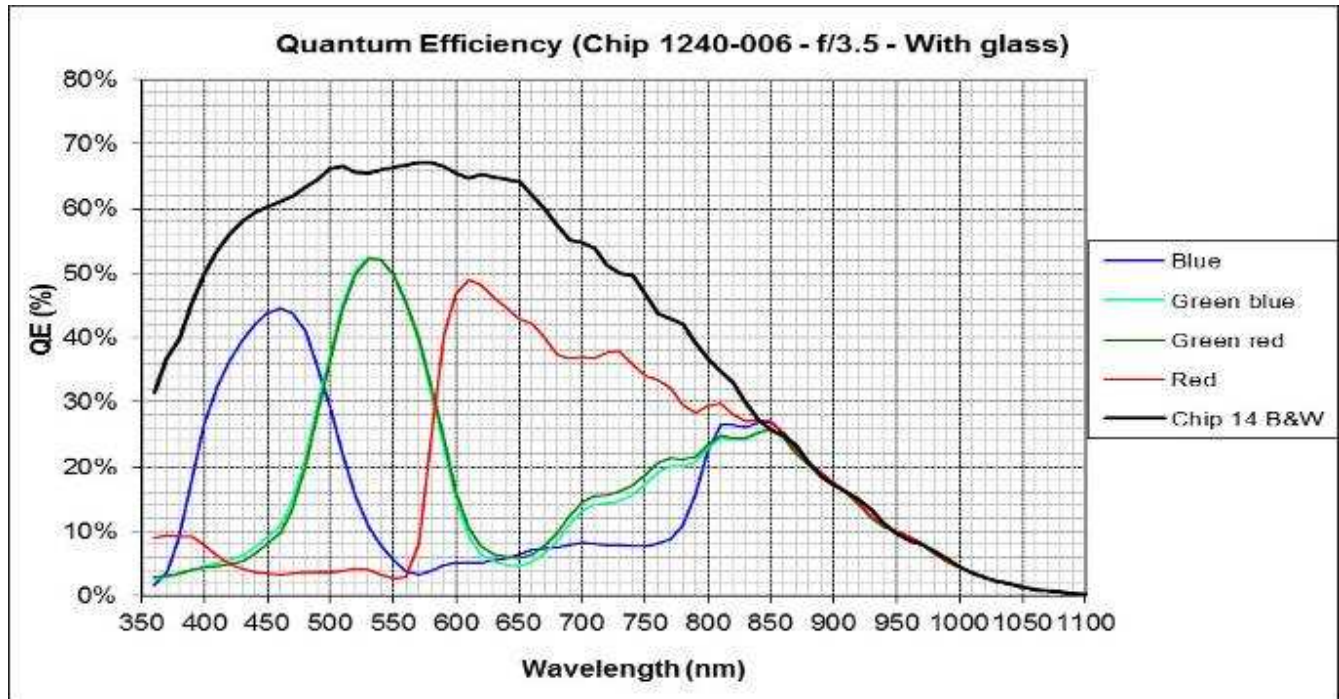

2.3.2 Spectral Response

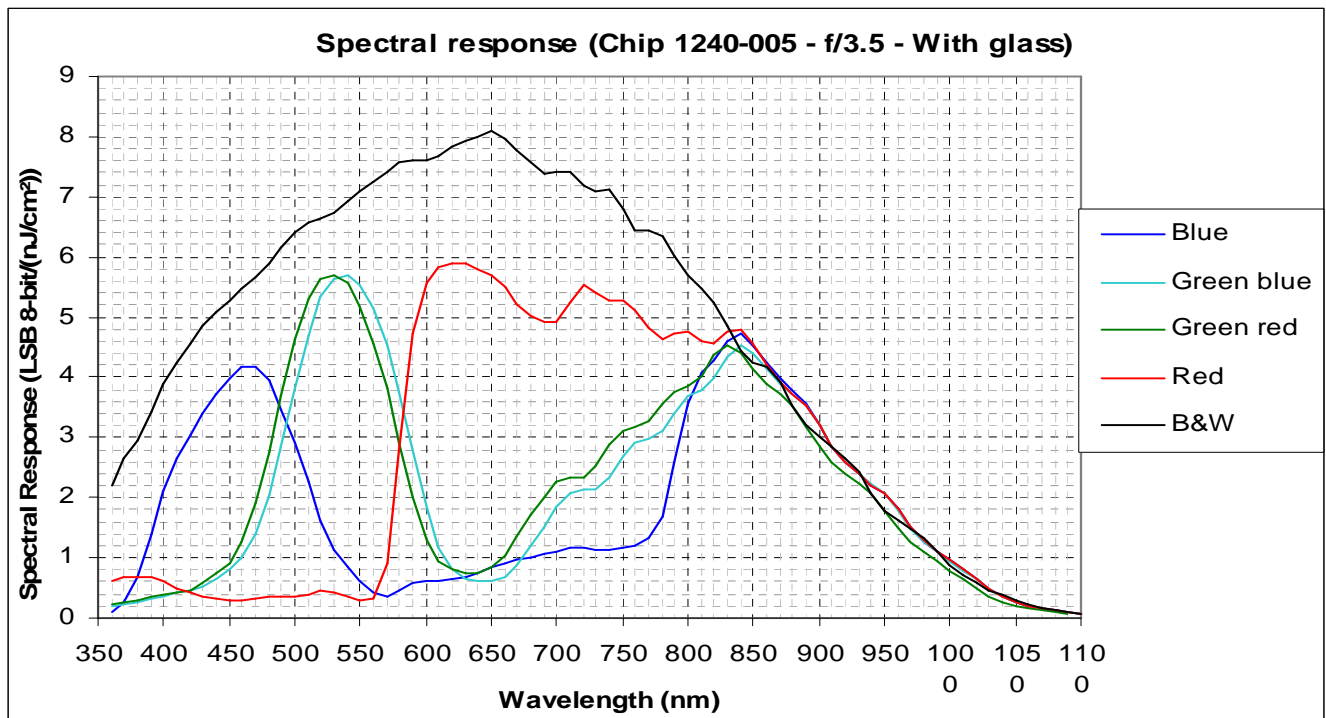

3 CAMERA HARDWARE INTERFACE

3.1 Mechanical Drawings

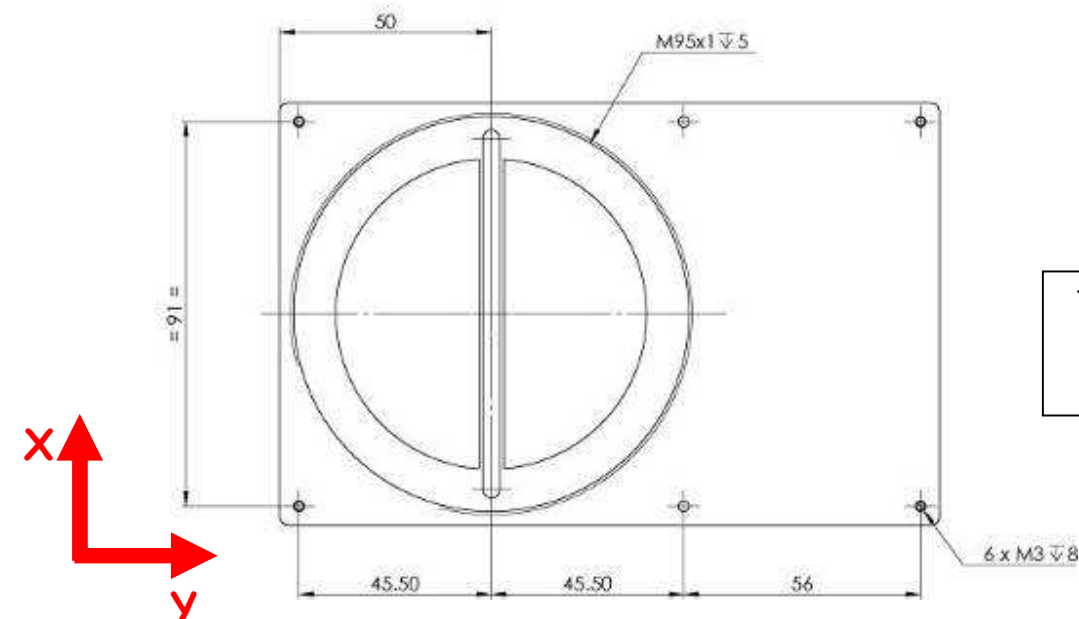
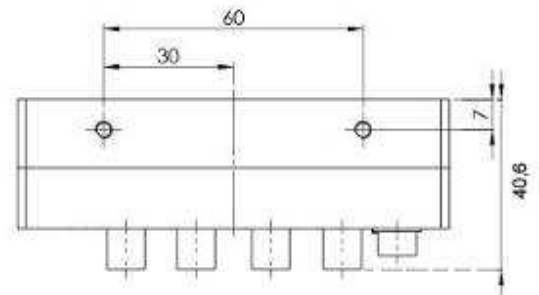
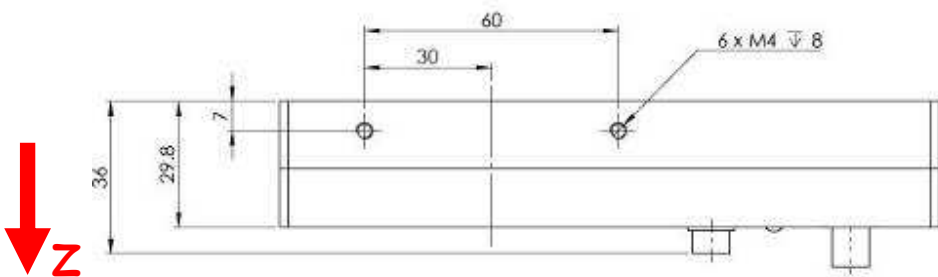
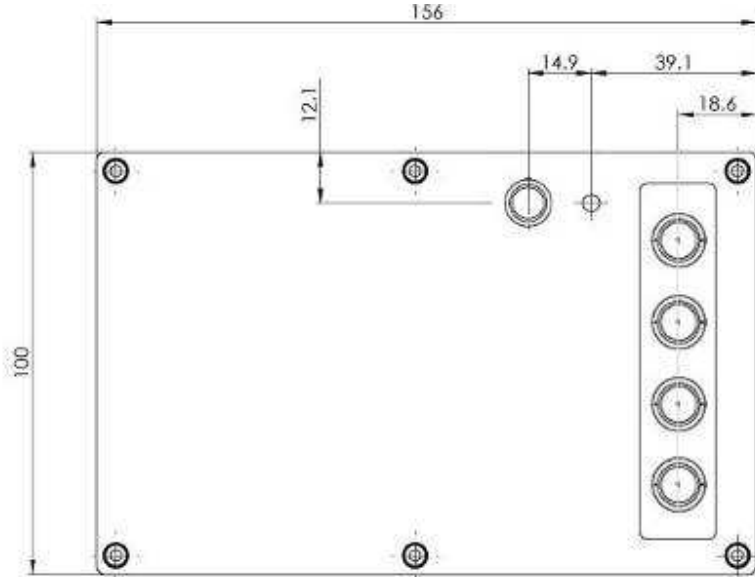

The Step file is available on the web :
www.e2v.com/cameras

ELIIXA+® 16k/8k CXP Color

Sensor alignment	
Z = -9.4 mm	±100µm
X = 9 mm	±100 µm
Y = 50mm	±100 µm
Flatness	±25 µm
Rotation (X,Y plan)	±0,1°
Tilt (versus lens mounting plane)	50µm

3.2 Input/output Connectors and LED

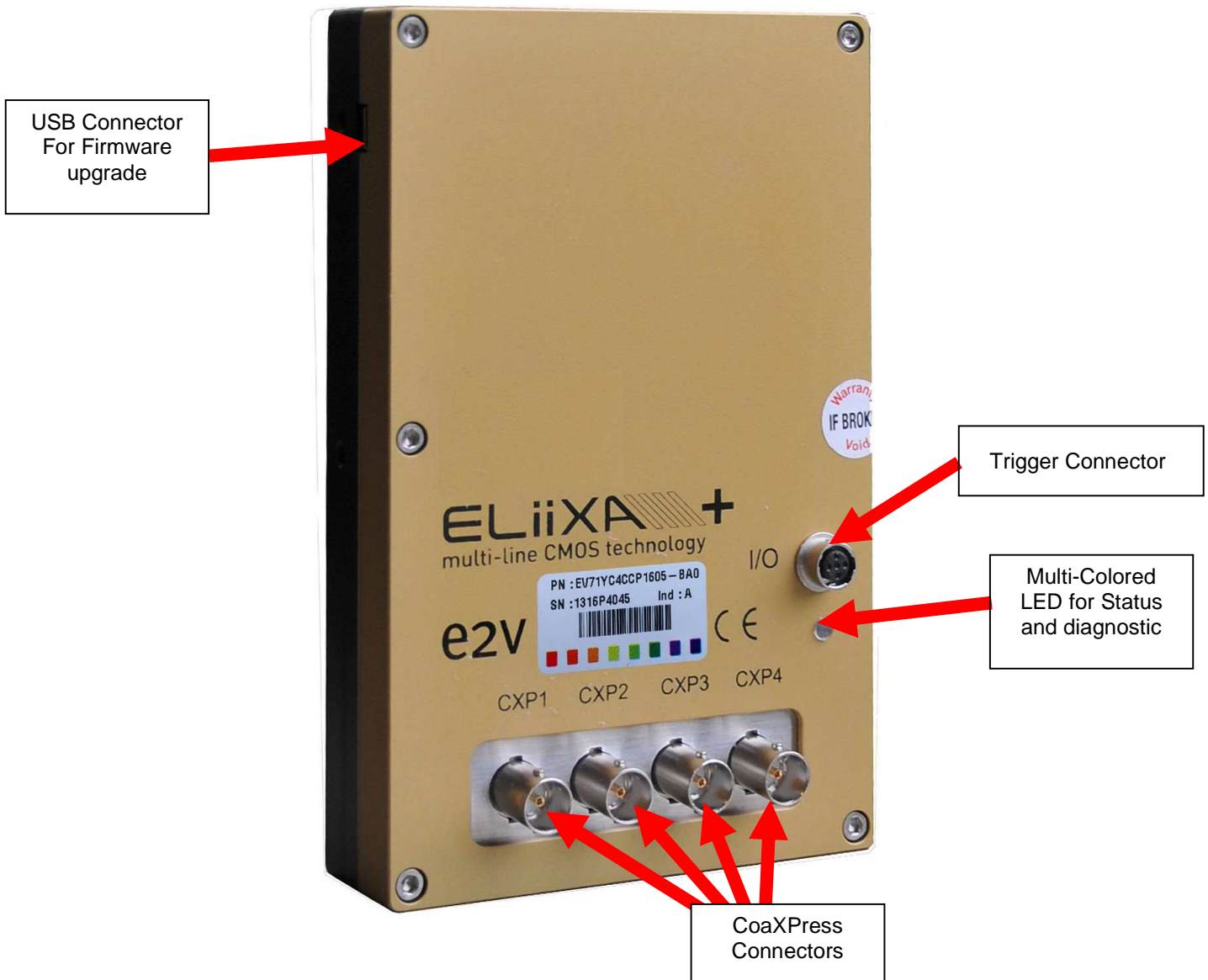

3.2.1 Power Over CoaXPress

The ELIIXA+ CXP is compliant with the Power Over CoaXPress : There is no Power connector as the power is delivered through the Coaxial Connectors 1 and 2.

In the Standard, the Power Over CoaXPress allows to deliver 13W (under 24V) per Channel.

The ELIIXA+ CXP requires 19W then two connectors are required for the power : The two first are used for this purpose.

If you want to Power ON the Camera you have to connect the Coaxial connector output 1 of the camera to the coaxial connector 1 of the Frame Grabber.









Note 1 : Only the connector 1 position is mandatory. The other 3 connectors can be inverted but the camera still needs the 2 first connectors to get its power and be able to start up.

Note 2 : Removing the 2 first connectors will shut down the Camera : You can reset the Camera by quickly (**less than 1s**) connect/disconnect the Connector CXP1 but after a longer shut down, you'll have to reboot the PC with the Camera full connected to the frame grabber in order to synchronize the discovery of each power line.

Note 3 : With some frame grabber you have access to a specific command (from the Frame Grabber interface) for shutting down/up the power of the CoaxPress : This solution, with the complete reboot, is the better solution to ensure a complete power On of the Camera.

3.2.2 Status LED Behaviour

The Power LED behavior detail is the following :

Colour and State		Meaning
Off		No power
Solid orange		System booting
Fast flash green Shown for a minimum of 1s even if the link detection is faster		Link detection in progress
Slow flash alternate red / green		Device / Host incompatible
Slow pulse green		Device / Host connected, but no data being transferred
Slow pulse orange		Device / Host connected, waiting for event (e.g. trigger, exposure pulse)
Solid green whenever data transferred (i.e. blinks synchronously with data)		Device / Host connected, data being transferred
500ms red pulse In case of multiple errors, there shall be at least 200ms green before the next error is indicated		Error during data transfer (e.g. CRC error, single bit error detected)
Fast flash red		System error (e.g. internal error)

3.2.3 Trigger Connector

Camera connector type:

Hirose HR10A-7R-5SB or compliant

Cable connector type:

Hirose HR10A-7P-5P (male) or compliant, Provided with the Camera

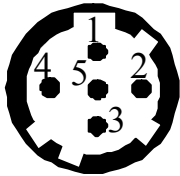

Receptacle viewed from camera back

Signal	Pin
LVDS IN1+ / TTL IN1	1
LVDS IN1-	2
LVDS IN2+ / TTL IN2	3
LVDS IN2-	4
GND	5

IN1/IN2 are connected respectively to Line0/Line1 and allow to get external line triggers or the forward/Reverse "Live" indication.

On the Connector side, the 120Ω termination is validated only if the input is switched in LVDS or RS422. The electrical schematic is detailed below :

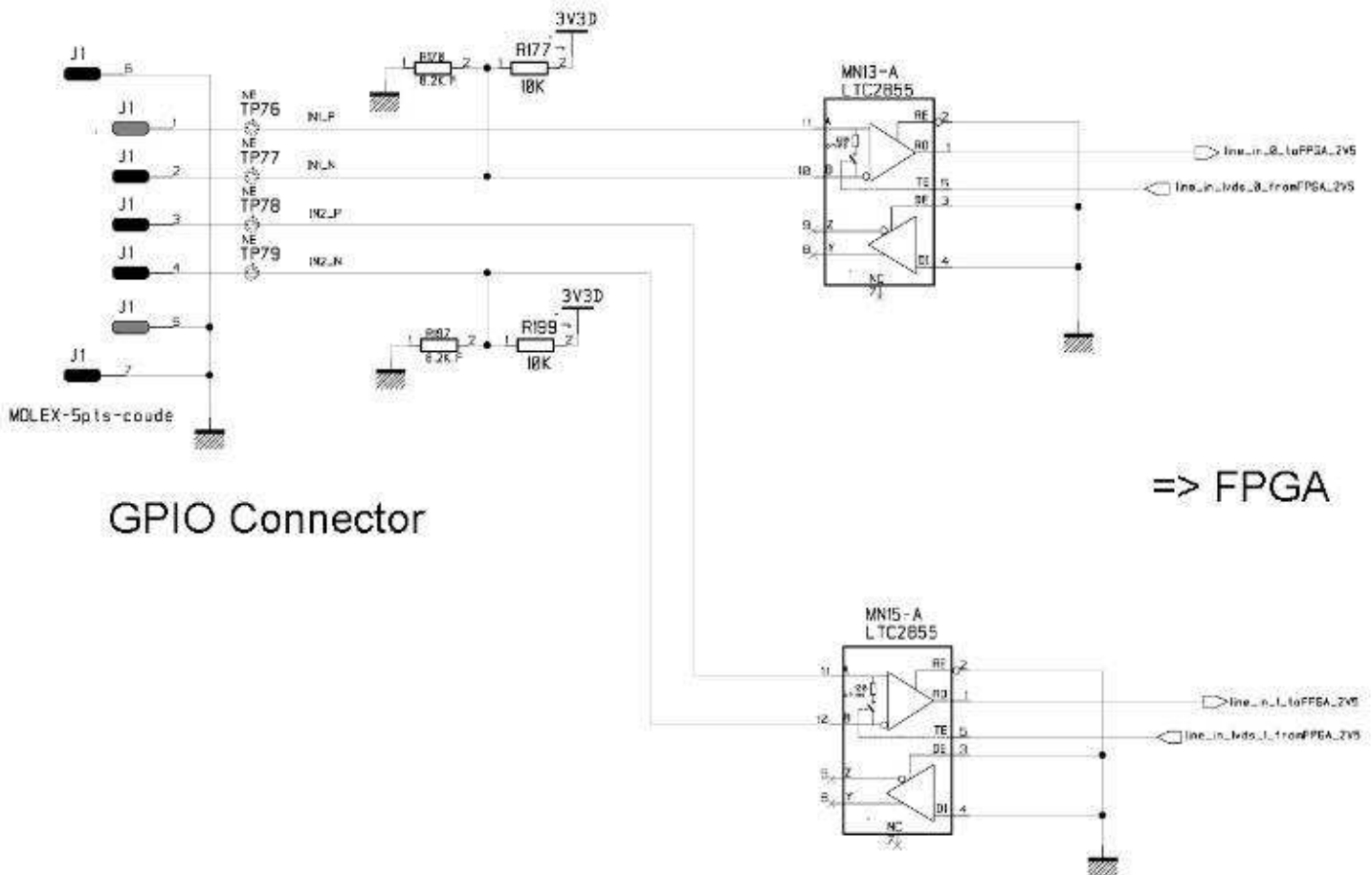

4 STANDARD CONFORMITY

The ELIIXA+ cameras have been tested using the following equipment:

- A shielded Trigger cable
- A 10m CoaXPress Cable for the data transfer, certified at 6Gb/s

e2v recommends using the same configuration to ensure the compliance with the following standards.

4.1 CE Conformity

The ELIIXA+ cameras comply with the requirements of the EMC (European) directive 2004/108/CE (EN50081-2, EN 61000-6-2) (see next page).

4.2 FCC Conformity

The ELIIXA+ cameras further comply with Part 15 of the FCC rules, which states that: Operation is subject to the following two conditions:

- This device may not cause harmful interference, and
- This device must accept any interference received, including interference that may cause undesired operation

This equipment has been tested and found to comply with the limits for Class A digital device, pursuant to part 15 of the FCC rules. These limits are designed to provide reasonable protection against harmful interference when the equipment is operated in a commercial environment. This equipment generates, uses and can radiate radio frequency energy and, if not installed and used in accordance with the instruction manual, may cause harmful interference to radio communications. Operation of this equipment in a residential area is likely to cause harmful interference in which case the user will be required to correct the interference at his own expense.

Warning: Changes or modifications to this unit not expressly approved by the party responsible for compliance could void the user's authority to operate this equipment.

4.3 RoHS Conformity

ELIIXA+ cameras comply with the requirements of the RoHS directive 2002/95/EC.

ELIIXA+® 16k/8k CXP Color

Declaration Number: NE31S208701

We,

e2v semiconductors
rue de Rochepleine
38120 Saint-Egrève
France

declare the product(s)

Product Family:

EliIXA+ 16k Cameras

Model Identification:

**EV71YC4MCL1605-Bxx / EV71YC4MCP1605-Bxx
EV71YC4CCP1605-Bxx**

x = 0-9-A-Z

in conformance with the requirements of the following standards:

EN55022 : ed. 2006, A class

EN61000-6-2 : ed. 2005

IEC 61000-4-2 : ed.2009
IEC 61000-4-3 : ed.2006 + A1/2008 +A2/2011
IEC 61000-4-4 : ed.2004
IEC 61000-4-5 : ed.2006
IEC 61000-4-6 : ed.2009
IEC 61000-4-11 : ed.2004

when used in conformity with the recommended set-up (as per the Product Specification or Data Sheet).

applicable to:

Information Technology Equipments (I.T.E.)

This (These) product(s) complies(y) with the requirements of the:

- Electromagnetic Compatibility Directive 2004/108/EC,
- CE Marking European Directive 93/68/EEC

and carry the CE marking accordingly.

Saint-Egrève, France, on June 13th, 2013



Martine WOOLF,
Quality Manager

5 GETTING STARTED

5.1 Out of the box

The contains of the Camera box is the following :

- One Camera ELIIXA+
- Trigger connector (Hirose HR10A-7P-5P-male or compliant)



There is no CDROM delivered with the Camera : This User Manual , and any other corresponding documents can be dowlaoded on the Web site.

Main Camera page : www.e2v.com/cameras

➤ Select the appropriate Camera Page (ELIIXA+)

5.2 Setting up in the system

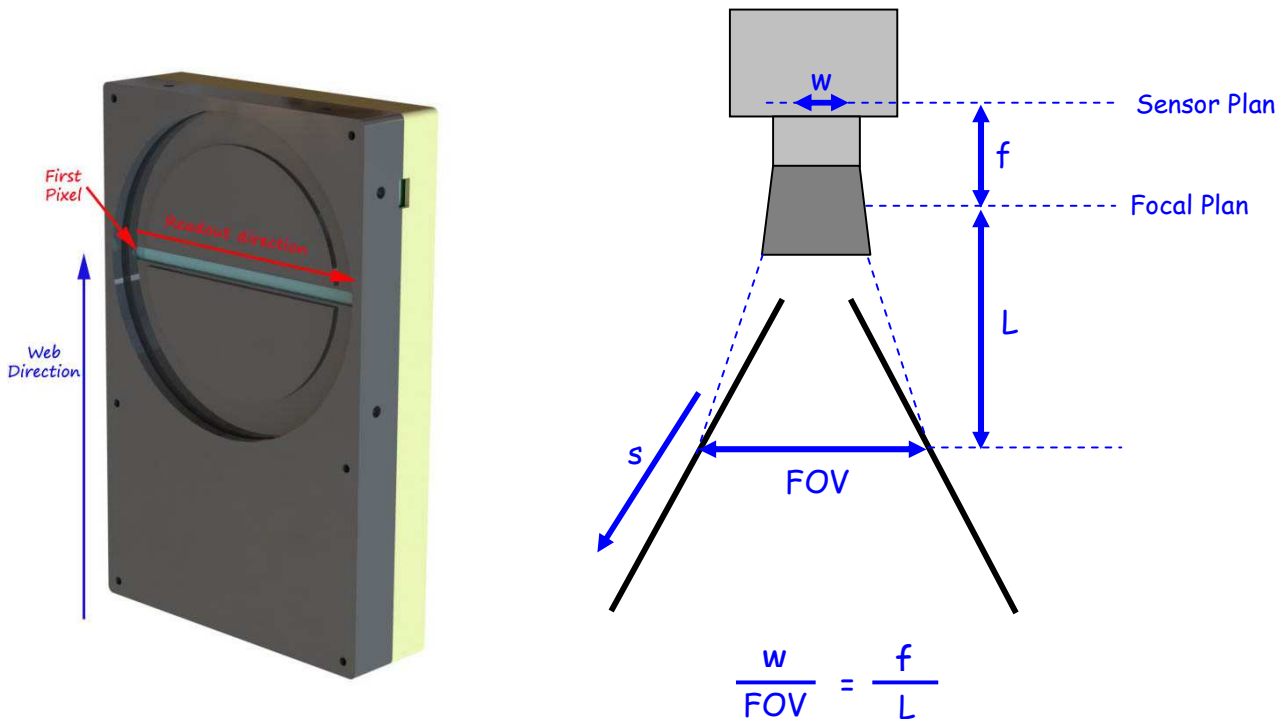

The Compliant Lenses and their accessories are detailed in Appendix E

6 CAMERA SOFTWARE INTERFACE

6.1 Control and Interface

The ELIIXA+ CoaxPress Camera is compliant with GenICam 2.1 and the SFNC 1.5 standards. This means that the Camera embeds its own definition and parameter description in an xml file. Most of these Parameters are compliant with the SNFC. The specific parameters (non SNFC) are still compliant with GenICam and can be detailed through the GenICam API process to the application.

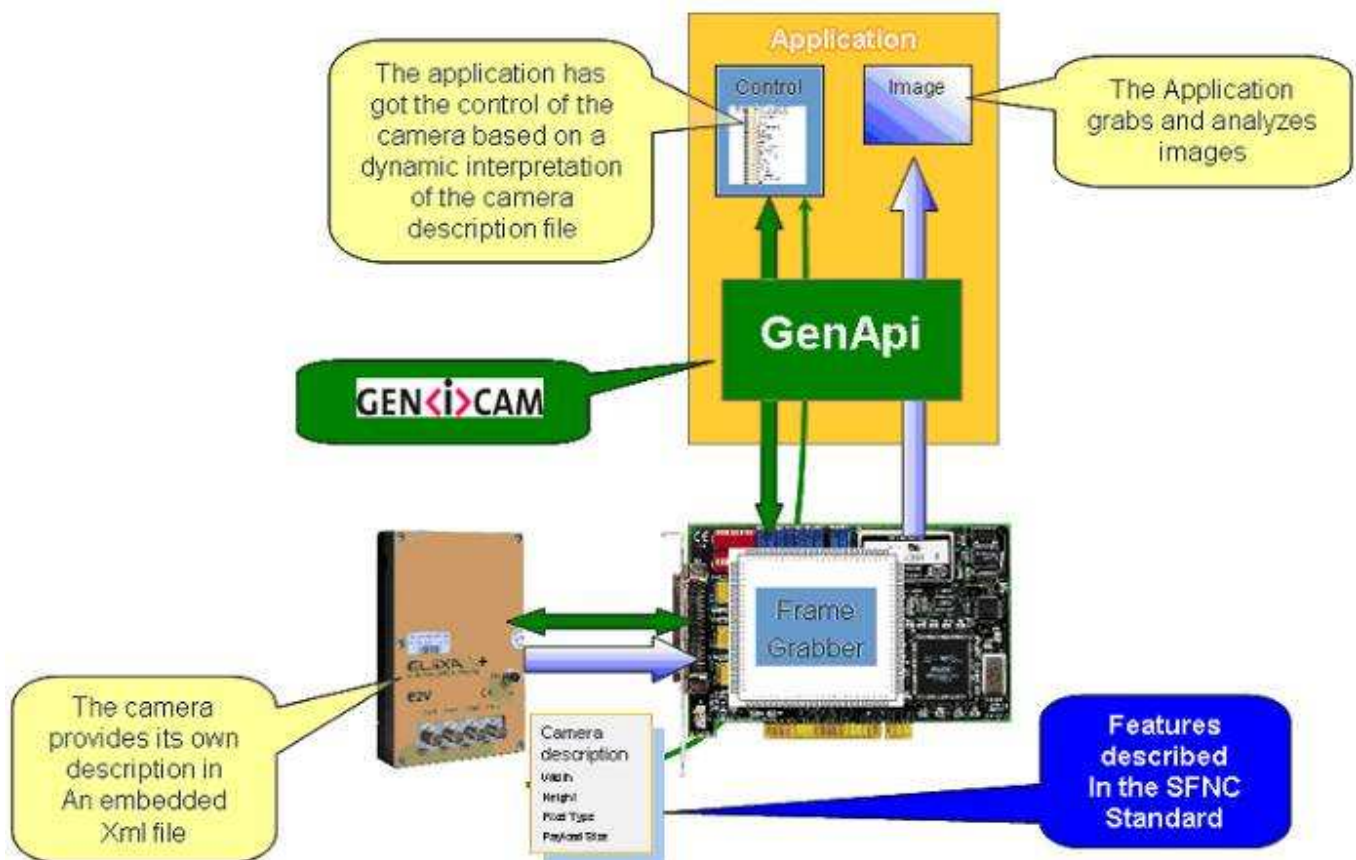

The Frame Grabber software is supposed to propose a feature Brother, based on GenICam, which lists and allows the modification of the parameters of the Camera. This feature brother based on GenICam API uploads the xml file of the parameters description embedded in the Camera.

Then the following description of the parameters and commands is based on the GenICam name of these parameters. Behind each parameter is a register address in the Camera memory. The mapping of these registers is not given in this manual because it can change from one version or the firmware to the next one.

6.2 Camera Commands

6.2.1 Device Control

These are Identification values of the Camera. They can be accessed in the "Device Control" section

Feature	Description
DeviceVendorName	Get camera vendor name as a string (including '\0')
DeviceModelName	Get camera model name as a string (including '\0')
DeviceFirmwareVersion	Get camera synthetic firmware version (PKG version) as a string (including '\0')
DeviceVersion	Get camera version as a string (hardware version) (including '\0')
DeviceManufacturerInfo	Get camera ID as a string (including '\0')
DeviceUserID	Get device user identifier as a string (including '\0')
DeviceID	Read Serial Nb
ElectronicBoardID	Read Electronic Board ID
DeviceSFNCVersionMajor	1
DeviceSFNCVersionMinor	5
DeviceSFNCVersionSubMinor	0
DeviceTemperatureSelector	Device Temperature selector
DeviceTemperature	Read Main board internal temperature (format signed Q10.2 = signed 8 bits, + 2 bits below comma. Value from -512 to +511) in °C
DeviceScanType	Linescan
Standby	Disable : Standby mode ("False") Enable : Standby mode ("True"), no more video available but save power and temperature
Status Register	
StatusWaitForTrigger	Bit 0 : true if camera waits for a trigger during more than 1s
Status trigger too fast	Bit 1 : true if camera trigger is too fast
<i>Reserved for Factory</i>	Bit 2 to 7
StatusWarningOverflow	Bit 8 : true if a an overflow occurs during FFC calibration or Tap balance (available only for integrator/user mode)
StatusWarningUnderflow	Bit 9 : true if a an underflow occurs during FFC calibration or Tap balance (available only for integrator/user mode)
<i>Reserved for Factory</i>	Bit 10
Scrolling direction	Bit 11 : 0 : forward, 1: reverse
StatusErrorHardware	Bit 16 : true if hardware error detected



A standby mode, what for ?

The Standby mode stops all activity on the sensor level. The power dissipation drops down to about **6W**. During the standby mode, the **grab is stopped**

Once the Standby mode turned off, the Camera recovers in less than **1ms** to send images again from the sensor.

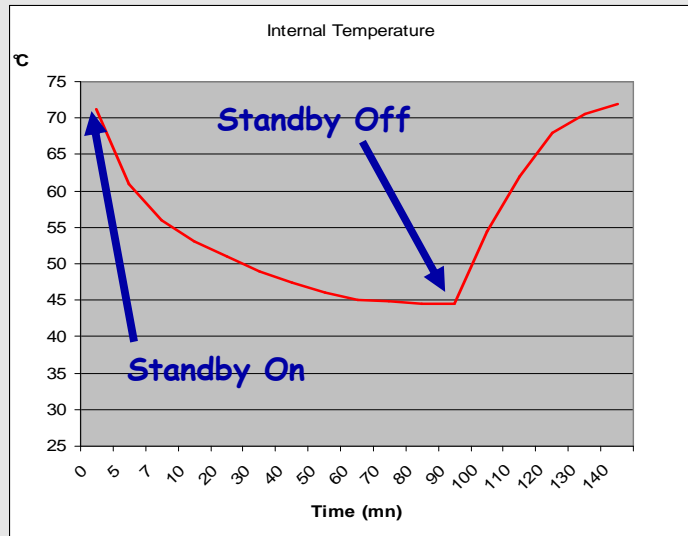

6.2.2 Image Format

Feature	Description
SensorWidth	Get sensor physical width : 16384
SensorHeight	1
WidthMax	Mapped on SensorWidth : 16384 or 8192 in binning mode
HeightMax	1
Width	Mapped on SensorWidth : 16384 or 8192 in binning mode
Height	1
InputSource	Signal source from CMOS sensor, processing chain activated
SensorMode	0 : True Color Mode (8192 pixels outputted) 1 : Full Definition Single Mode (16386 Pixels Outputted) 2 : Full Definition Enhanced Mode (16386 Pixels Outputted)
PixelFormat	0x0401: RGB Mono8
Color Selection	Disable color components Bit 0 : Disable Red color Bit 1 : Disable Blue color Bit 2 : Disable Green colors (both Green _{Red} and Green _{Blue})
TestImageSelector	Off : Image pattern disabled Grey Horizontal Ramp : Set image pattern to a Grey Horizontal Ramp, White : Set image pattern to a full White pattern. Gray Pattern : Set image pattern to a gray pattern (Half Dynamic) Color RGBW Pattern : Set image pattern to a RGB+W Pattern, GreyVerticalRampMoving : Set image pattern to Grey Vertical Ramp Moving

6.2.2.1 Structure of the Sensor

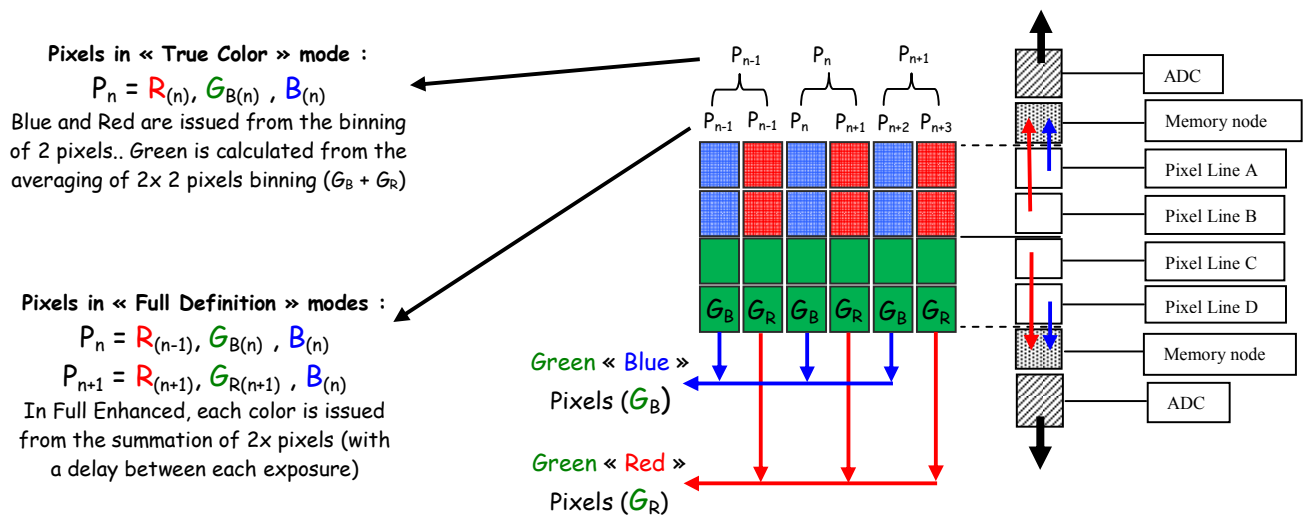

Full Exposure Control



As the « Full Definition Enhanced » color mode is performing an internal Time delay exposure on the Four Color lines, normally, the variation of the Exposure time should not be possible in this sensor mode.

Thanks to an e2v licensed solution, two of the Exposure controlled mode (Ext Trig with internal or External exposure control) are still available in this color mode.

The "Free Run" synchronization mode (line Trigger and Exposure time controlled internally) is not available in the "FDE" color mode.

6.2.2.2 Forward/Reverse

Forward/reverse information has to be set correctly as soon as one of the following modes : "2S", "4S" or 2SB of the sensor is set.

In these modes, the sensor/Camera need to know what is the real order of the lines for the exposure delays.

The Forward direction is defined as detailed below :

Note : The delay for the Camera to take in account a change in the ScanDirection value is **200ms**

This information can be set dynamically by using one of the two External Trig lines (Line0 or Line1) of the GPIO connector (change the direction "on the fly").

In these case, the Trigger low level signification is :

- "0" : Forward.
- "1" : Reverse

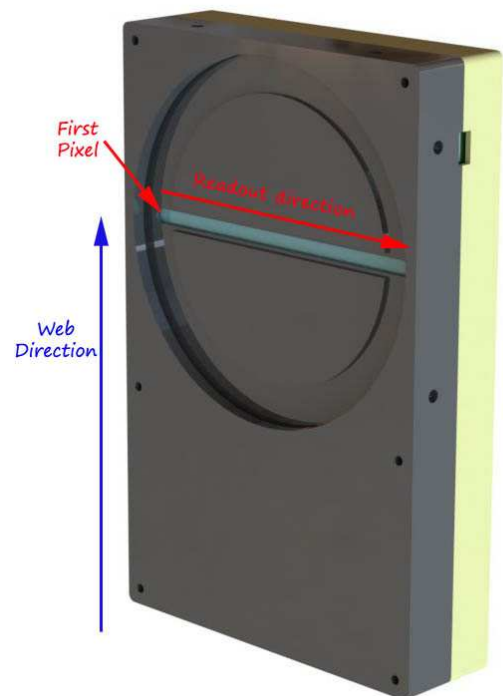

6.2.2.3 Test Image Pattern Selector

This selection Defines if the data comes from the normal Sensor operation and FPGA Chain or from digital patterns generated at the end of the FPGA. This is mainly useful to detect some interfacing or connection issues.

- To switch to Cmos sensor image
- Grey Horizontal Ramp (Fixed) : **See AppendixA**
- White Pattern (Uniform white image : 255)
- Grey Pattern (Uniform middle Grey : 128 on each color)
- RGBW Pattern **See AppendixA**
- Grey vertical Ramp (moving)

When any of the Test pattern is enabled, the whole processing chain of the FPGA is disabled.

Note : When the camera is set with the RGBW pattern test, it's no more taking in account the Line Trigger and working in Free Run (line period controlled by the camera)

6.2.3 Acquisition Control

The Acquisition Control section describes all features related to image acquisition, including the trigger and exposure control. It describes the basic model for acquisition and the typical behavior of the device.

An **Acquisition** is defined as the capture of a sequence of one or many **Frame(s)**. This Acquisition mode and its command is managed by the Frame Grabber.

A **Frame** is defined as the capture of **Width** pixels x **Height** lines.

As for the Acquisition Mode, the **Frame Management** (Start, stop ...) is also managed by the Frame Grabber.

The ELIIXA+ CXP Camera is considered as a LineScan Camera (as in the CameraLink version) then only deals with the Line/Exposure Triggers.

A **Line** starts with an optional **Exposure** period and ends with the completion of the sensor read out.

The Line/Exposure Triggers can be connected :

- Either on the GPIO connector of the Camera (2x Lines Triggers : Line0/1 available if Forward/reverse command is controlled by software)
- Or by the CoaxPress Cable : Only one Trigger available (Line2).

If the single CoaxPress Trigger is used, the Synchronization mode using 2xTriggers can't be used.

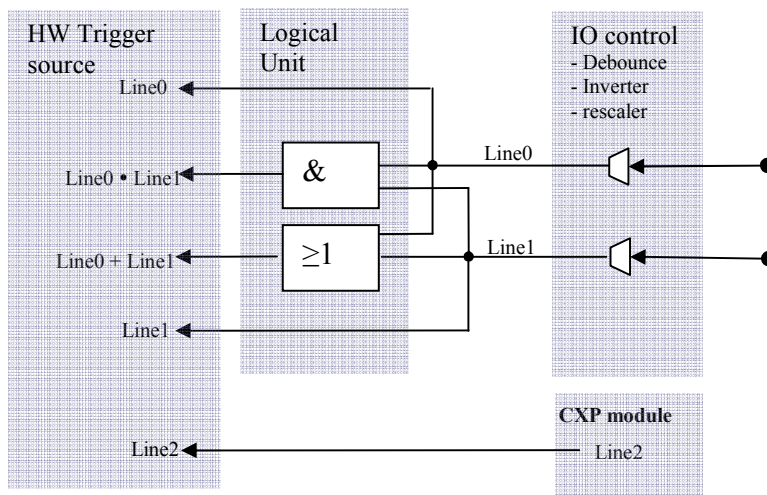
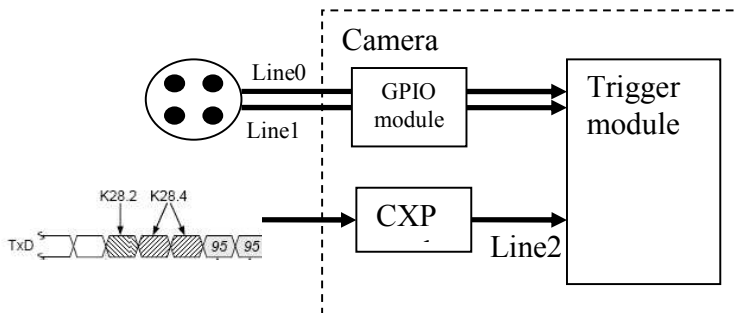

6.2.3.1 External Triggers on GPIO Connector

An External GPIO connector allows the camera to used 2 lines for triggering (Line0 and Line1)
 The end-user has the responsibility of the definition of the triggering system.
 The mapping describes all features available to define a trigger system

6.2.3.2 CXP Trigger

CXP specification allows the frame grabber to send triggers through the low speed link0 (@20MHz)
 The CXP specification describes the behavior of the trigger, where only the edge of the signal and a timer to limit the latency is described.

For the camera, the CXP trigger is consider to be the "line2". The Frame grabber itself can also manage several lines, timers, counter and finally send this single CXP trigger to the camera.

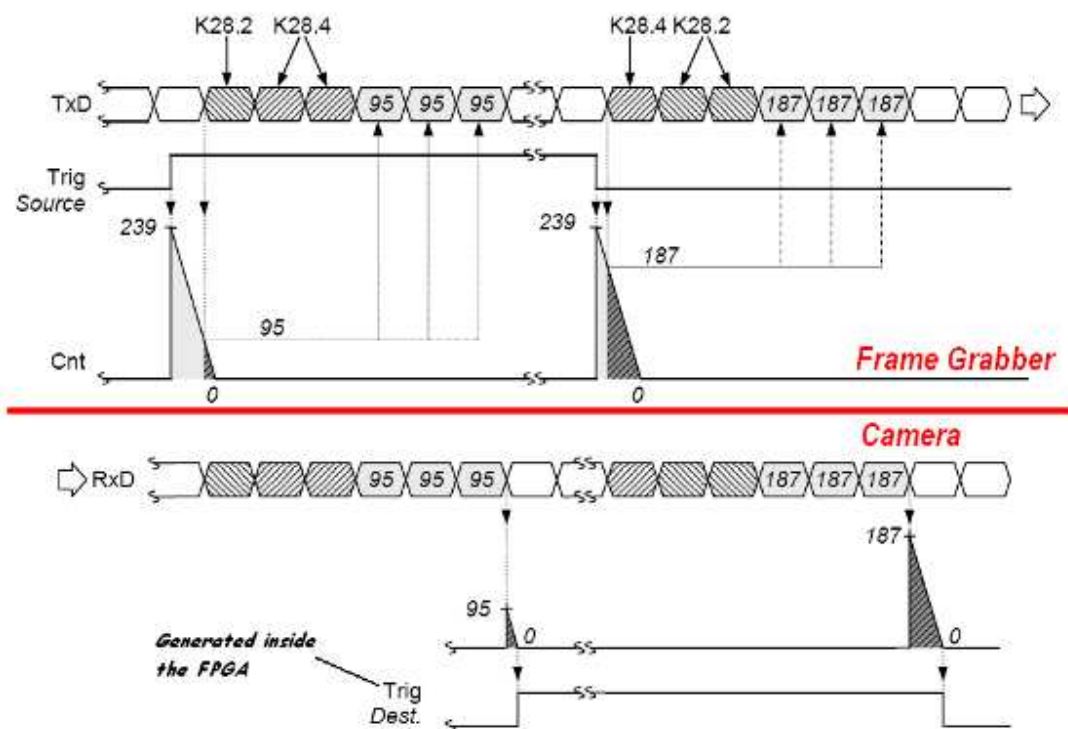

ELIIXA+® 16k/8k CXP Color

Feature	Description
AcquisitionMode	Continuous (on Line Scan side)
AcquisitionStart	Start the acquisition
AcquisitionStop	Stop the acquisition
LinePeriod	Set line period, from 10,5µs to 6553,5µs, by step 0,1µs
LinePeriodMin	Get current line period min : 10,5µs
ExposureTime	Set exposure time, from 1,5µs to 6553,5µs, by step 0,1µs
Synchronisation Mode (non SFNC)	<p>These are preset for the Camera Synchronization mode (detailed above) :</p> <p>Mode 0 : Internal Line Trigger with Exposure Time internally controlled (*)</p> <p>Mode 1 : External Line Trigger with Exposure Time internally controlled (**)</p> <p>Mode 2 : External Line Trigger with maximum Exposure Time</p> <p>Mode 3 : One External Line Trigger Exposure Time Externally controlled (**)</p> <p>Mode 4 : Two External Line Trigger Exposure Time Externally controlled (*)</p> <p>Mode 5 : Internal Line Trigger with maximum Exposure Time</p>
ExposureMode	Operation mode for the exposure control: <ul style="list-style-type: none"> - Off - Timed - TriggerWidth - TriggerControlled
Triggers	
TriggerSelector	<ul style="list-style-type: none"> - ExposureStart, - ExposureEnd, - ExposureActive
<i>The 3 following parameters are relative to the selection of the TriggerSelector above</i>	
TriggerMode	Enable the Trigger : <ul style="list-style-type: none"> - Off - On
TriggerSource	Specifies the source for the trigger : <ul style="list-style-type: none"> - Software - Line0 - Line1 - Line2 : CoaxPress Trigger - TimerEnd1 - TimerEnd2 - CounterStart1 - CounterStart2 - CounterEnd1 - CounterEnd2 - Line0 OR line1 - Line0 AND Line1 - RescalerLine
TriggerActivation	Specifies the activation mode of the trigger : <ul style="list-style-type: none"> - RisingEdge - FallingEdge - AnyEdge, - LevelHigh - LevelLow
Scanning Direction	
ScanDirectionMode	<p>Forward: Set scan direction to "forward"</p> <p>Reverse: Set scan direction to "reverse"</p> <p>Externally controlled: Set scan direction to Externally controlled direction via the selected Trigger Input (0=forward, 1=reverse)</p>
ExternalLine	Select the Hardware source (Ext Trigger connector) of the Forward/Reverse indication : <ul style="list-style-type: none"> - Line0 - Line1 Disabled is managed internally (ScanDirectionMode parameter)
(*) <i>Not available when Sensor is set in "Full Definition Enhanced" mode.</i>	
(**) <i>"Full Exposure control" mode activated when Sensor is set in "Full Definition Enhanced" mode.</i>	

6.2.3.3 Trigger Presets

Several triggers are pre-defined to help the user to define its trigger configuration.
For external trigger, 5 modes are available (Same than in the Camera Link version) :

	Exposure Mode	Acquisition Mode	TriggerSelector					
			ExposureActive		ExposureStart		ExposureStop	
Mode 0	Timed	Continuous	TriggerMode	Off	TriggerMode	Off	TriggerMode	Off
			TriggerSource	NA	TriggerSource	NA	TriggerSource	NA
			TriggerActivation	NA	TriggerActivation	NA	TriggerActivation	NA
Mode 1	Timed	Continuous	TriggerMode	Off	TriggerMode	On	TriggerMode	Off
			TriggerSource	NA	TriggerSource	Line0	TriggerSource	NA
			TriggerActivation	NA	TriggerActivation	RisingEdge	TriggerActivation	NA
Mode 2	Off	Continuous	TriggerMode	Off	TriggerMode	On	TriggerMode	Off
			TriggerSource	NA	TriggerSource	Line0	TriggerSource	NA
			TriggerActivation	NA	TriggerActivation	RisingEdge	TriggerActivation	NA
Mode 3	TriggerWidth	Continuous	TriggerMode	On	TriggerMode	Off	TriggerMode	Off
			TriggerSource	Line0	TriggerSource	NA	TriggerSource	NA
			TriggerActivation	LevelLow	TriggerActivation	NA	TriggerActivation	NA
Mode 4	TriggerControlled	Continuous	TriggerMode	Off	TriggerMode	On	TriggerMode	On
			TriggerSource	NA	TriggerSource	Line0	TriggerSource	Line1
			TriggerActivation	NA	TriggerActivation	RisingEdge	TriggerActivation	RisingEdge
Mode 5	Off	Continuous	TriggerMode	Off	TriggerMode	Off	TriggerMode	Off
			TriggerSource	NA	TriggerSource	NA	TriggerSource	NA
			TriggerActivation	NA	TriggerActivation	NA	TriggerActivation	NA

For CXP triggers, only one line is available where only the rising and falling edge is defined.

Mode 0 :

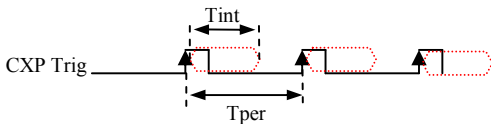

Mode 1 :

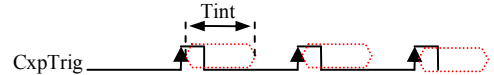

Mode 2 :



Mode 3 :

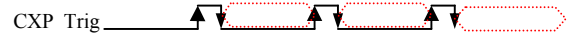

Mode 4 :

Not available because only 1 Trigger CXP

Mode 5 :

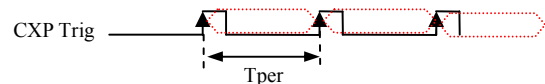

The Timing diagrams associated to each Synchronization mode and the Timing values associated are detailed in the APPENDIX B of this document.

Rescaler	
Feature Name	Description
TriggerRescalerSource	Selection of the input source of the Rescaler : - Line0 - Line1 - Bypass Rescaler
TriggerRescalerMultiplier	Multiplier factor : 1 to 4096
TriggerRescalerDivider	Divider factor : 1 to 4096
TriggerRescalerGranularity	- 20 ns - 80 ns - 320 ns - 5120 ns
TriggerRescalerCountInt	count_int overflow
TriggerRescalerCountIntOverflow	count_int counter of rescaler bloc count between 2 input trig

6.2.3.4 Rescaler

The camera has two registers per line which can define a rescaler: a multiplier and a divider. With these two registers, the end-user can change the frequency of the line.

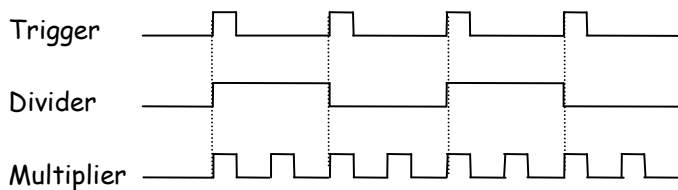

The generated line has always a 50% duty cycle. With the combination of a multiplier and divider, the system can generate any frequency

The system must sample the input signal to compute its frequency.

Two parameters define the sample settings:

- RescalerSize
- Granularity

The Rescaler Size defines the maximum number of samples. Two values are possible: 12bit (4096 samples) or 16bit (65536 samples).

The Granularity allows the rescaler to generate the sample periodicity. Four values are possible: 1, 4, 16 or 256 system clock cycles.

The system clock period is 20ns. So the time between samples is (Granularity x 20ns)

With these two parameters, the user must determine the best sample range. It is the user responsibility to configure the rescaler.

ELIIXA+® 16k/8k CXP Color

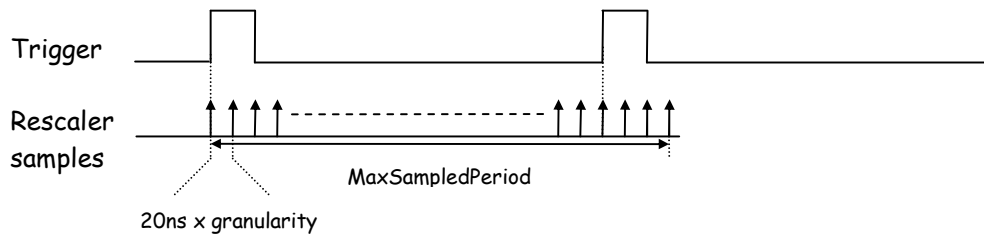

The *MaxSampledPeriod* must be as close as possible to the trigger period while still being longer

$$\text{MaxSampledPeriod} = 20\text{ns} \times \text{granularity} \times 2^{\text{rescalerSize}}$$

The array below gives the *MaxSampledPeriod* in millisecond

RescalerSize	12	16
granularity		
1	8,19E-02	1,31E+00
4	3,28E-01	5,24E+00
16	1,31E+00	2,10E+01
256	2,10E+01	3,36E+02

The trigger frequency is calculated at each Trigger pulse.

6.2.4 Digital I/O Control

Feature Name	Description
LineStatusAll	Return the current status of all lines (bit0 for Line0, bit1 for Line1, bit2 for Line2) A VOIR
LineSelector	- Line0, - Line1
<i>The 5 following parameters are relative to the selection of the LineSelector above</i>	
LineMode	Define the physical line as input {Input} - Input - Output
LineInverter	Define the signal inversion: - False - True
LineDebounceFilter	Activate debounce filter - False - True
LineStatus	Return the current status of the selected : - False - True
LineFormat	Select the electrical format of the selected line : - TTL - LVDS - RS422

6.2.5 Counters and Timers Control

Counters	
CounterSelector	Select which counter to be configured - Counter1, - Counter2
<i>All the following parameters are relative to the selection of the CounterSelector above</i>	
CounterTriggerSource	Select the signal that start (reset) the counter: 0: Off 9: ExposureStart 10: ExposureEnd 11: Line0 12: Line1 13: Line2 16: Counter1End 17: Counter2End 18: Timer1End 19: Timer2End
CounterTriggerActivation	Select the type of activation for the trigger to start (reset) the counter : 0: RisingEdge 1: FallingEdge 2: AnyEdge, 3: LevelHigh 4: LevelLow
CounterEventSource	Select the event that will be the source to increment the counter : 0: Off 9: ExposureStart 10: ExposureEnd 11: Line0 12: Line1 13: Line2 16: Counter1End 17: Counter2End 18: Timer1End 19: Timer2End 21: MissedTrigger
CounterEventActivation	Select the type of activation for the event that increment the counter : 0: RisingEdge 1: FallingEdge 2: AnyEdge, 3: LevelHigh 4: LevelLow
CounterStatus	Get counter status : 0: CounterIdle 1: CounterTriggerWait 2: CounterActive, 3: CounterCompleted 4: CounterOverflow
CounterDuration	Set the counter duration (or number of events) before CounterEnd event is generated
CounterReset	Reset the selected counter
CounterValue	Read the current value of the selected counter
CounterValueAtReset	Read the value of the selected counter, when the counter was reset by a trigger or by an explicit CounterReset.

ELIIXA+® 16k/8k CXP Color

Counters	
CounterResetSource	Select the signal that reset the counter: 0: Off 1: Software 2: Line0, 3: Line1 4: Line2
CounterResetActivation	Select the type of activation for the counter reset source : 0: RisingEdge 1: FallingEdge 2: AnyEdge, 3: LevelHigh 4: LevelLow

Timers	
TimerSelector	Select which timer to be configured - Timer1, - Timer2
<i>All the following parameters are relative to the selection of the TimerSelector above</i>	
TimerTriggerSource	Select which internal signal will trigger the timer: 0: Off 9: ExposureStart 10: ExposureEnd 11: Line0 12: Line1 13: Line2 16: Counter1End 17: Counter2End 18: Timer1End 19: Timer2End
TimerTriggerActivation	Select the type of signal that will trig the timer: 0: RisingEdge 1: FallingEdge 2: AnyEdge, 3: LevelHigh 4: LevelLow
TimerDelay	Set the delay in μs from the TimerTrigger to the actual Timer pulse output ((0,31/30MHz, step 1/30MHz)
TimerStatus	Get counter status 0: TimerIdle 1: TimerTriggerWait 2: TimerActive, 3: TimerCompleted
TimerDuration	Set the length of the ouput pulse in μs (0,65535, step 0.1)
TimerValue	Return the actual value of the selected timer (0,65535/30MHz, step 1/30MHz)

6.2.5.1 Counters

Here is a following description of the counters :



6.2.5.2 Timers

Here is a following description of the counters :

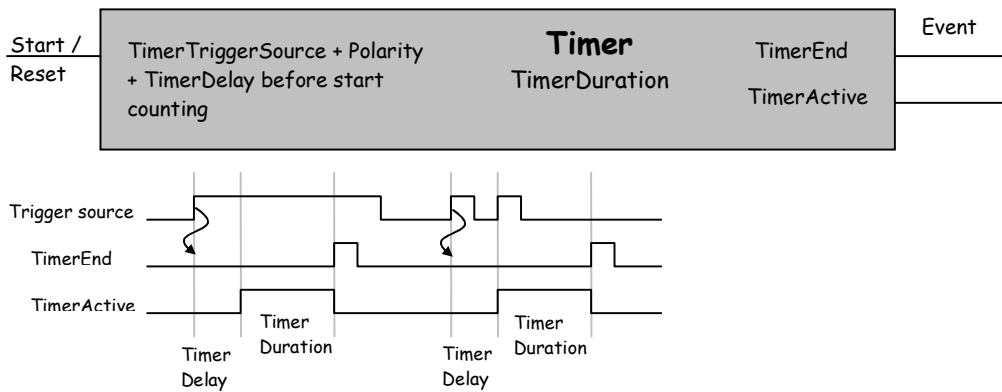

6.2.6 Gain and Offset

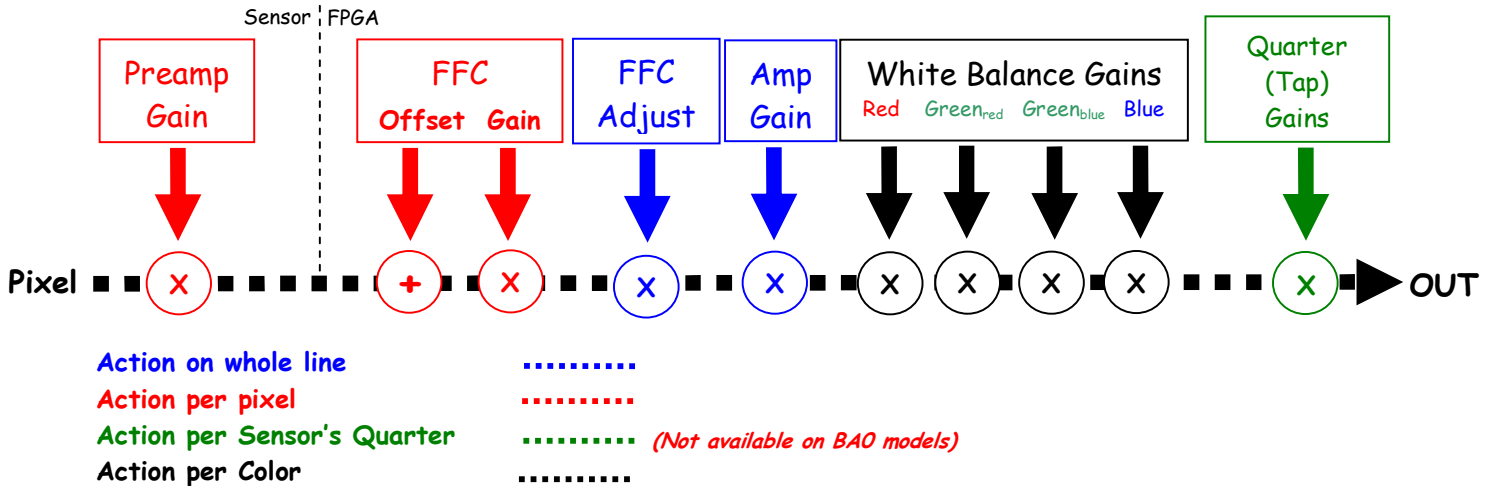

Analog Gain in the ADC

The only analog Gain available in the ELIIXA+ is located at the sensor level, in the ADC converter. This "Preamp Gain" is in fact a variation of the ramp of the comparator of the ADC. Then 3 Values are available : x1, x2 and x4. A gain x1 in a 12 bits conversion is equivalent to x4 in 10 bits.

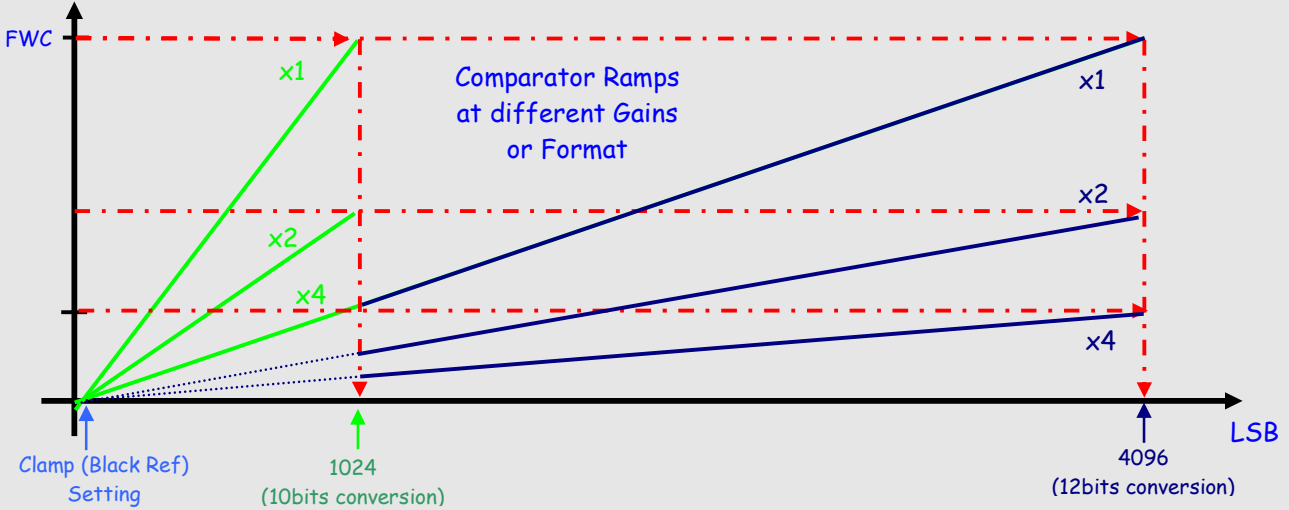

ELIIXA+® 16k/8k CXP Color

Feature	Description
PreampGain	Set pre amplifier gain (analog gain) to: x1: (0dB) x2: (6dB) x4: (12dB)
Gain	Set Adjustment gain from 0dB to +8 dB
Digital Quarter Gain Selector	Select the Quarter Gain (1-4) to be set by Digital Quarter Gain
Digital Quarter Gain	Value of the Quarter Gain selected by the Digital Quarter Gain Selector (-128 to +127)
Quarter Balance Enable	Enables the quarter Gains (0 : Gains disabled).
White Balance Enable	Enables the White Balance Gains (below) 0 : Disabled 1 : Enabled
Digital Red	Set gain for Red color form 0 (0db) to 6193 (8dB)
Digital Blue	Set gain for Blue color form 0 (0db) to 6193 (8dB)
Digital Green (Red)	Set gain for Green _{Red} color form 0 (0db) to 6193 (8dB)
Digital Green (Blue)	Set gain for Green _{Blue} color form 0 (0db) to 6193 (8dB)
AutoWhiteBalanceStart	Auto White Balance calibration Control : 0 : Abort the White Balance 1 : Launch the White Balance Calibration

6.2.6.1 White Balance

As described in chapter 6.2.2.1, the structure of the sensor differentiates Green pixels facing Blue or Red pixels. Then the white balance is associated with 4 color Gains :

- Red Gain
- Green_{Red} Gain
- Green_{Blue} Gain
- Blue Gain

The Color Selection or enabling (Image Format Chapter) can affect the way you're performing the white balance : For example, if you disable the Blue and the Red color, the "White Balance" will be performed only between the two Green Gains.

The dissociation of Green (blue) and Green (Red) is justified by the possible difference of response of the two types of Green because of their respective neighbor color influence and then the necessity to tune them separately.

As usual, for a perfect White balance, provide to the Camera a non-saturating white (gray) target in the center of the sensor.

The White balance has to be performed after the Flat Field Correction as each color is performing its own FFC with its own reference.

In any case, the best tuning of the Camera Gains is performed from the left to the right of the Gain Chain described above : Preamp Gain first and quarter Gains last (if required).

6.2.7 Flat Field Correction



How is performed the Flat Field Correction ?

What is the Flat Field correction (FFC) ?

The Flat Field Correction is a digital correction on each pixel which allows :

- To correct the Pixel PRNU (Pixel Response Non Uniformity) and DSNU (Dark Signal Non Uniformity)
- To Correct the shading due to the lens
- To correct the Light source non uniformity

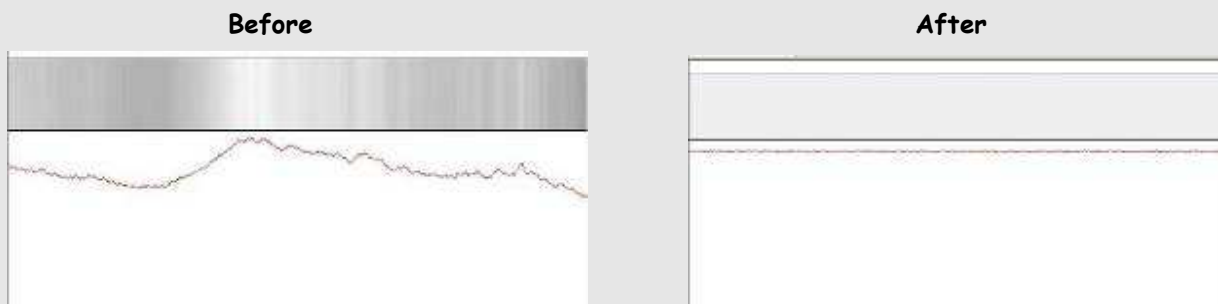

How is calculated / Applied the FFC ?

The FFC is a digital correction on the pixel level for both *Gain* and *Offset*.

- Each Pixel is corrected with :
 - An *Offset* on 8 bits (Signed Int 5.3). They cover a dynamic of $\pm 16\text{LSB}$ in 12bits with a resolution of $1/8\text{ LSB}$ 12bits.
 - A *Gain* on 14 bits (Unsigned Int 14) with a max gain value of $\times 5^{(*)}$
 - The calculation of the new pixel value is : $P' = (P + \text{Off}).(1 + \text{Gain}/1024^{(*)})$

The FFC is always processed separately on each color and with the max pixel value of each color as reference. Then the white balance has to be performed after the FFC.

How to perform the Flat Field Correction ?

FPN/DSNU Calibration

- Cover the lens
- Launch the FPN Calibration : Grab and calculation is performed in few seconds

PRNU Calibration

The User must propose a white/gray uniform target to the Camera (not a fixed paper).

The Gain/Light conditions must give a non saturated image in any Line.

The Camera must be set in the final conditions of Light/ Gain and in the final position in the System.

If required, set a user target for the FFC adjust and enable it.

- White uniform (moving) target
- Launch the FFC
- Enable the FFC
- You can save the FFC result (both FPN+PRNU in the same time) in one of the 4 x FFC User Banks.
- The user target and Gain are saved with the associated FFC in the same memory.

Advices

The ELIIXA+ Cameras have 4 x FFC Banks to save 4 x different FFC calibrations. You can use this feature if your system needs some different conditions of lightning and/or Gain because of the inspection of different objects : You can perform one FFC per condition of Gain/setting of the Camera (4 Max) and recall one of the four global settings (Camera Configuration + FFC + Line Balance) when required.

Feature	Description
FFCEnable	- Disable Flat Field Correction - Enable Flat Field Correction
FPNReset	Reset FPN coefficients of the RAM memory
PRNUReset	Reset PRNU coefficients of the RAM memory
FPNValueAll	Memory containing FPN Format: S9.1 => -256..+255.5 step $\frac{1}{2}$
FPNValueSize	Integer providing FPN value size in byte
PRNUValueAll	Memory containing PRNU Value from 0 to 4095 Format: U2.10 : (1+coeff/1024) => x1..x4.999877 step 1/1024
PRNUValueSize	Integer providing PRNU value size in byte
FFCCalibrationCtrl	FFC calibration 0 = Abort PRNU calibration by setting it to "Off" (no effect if already stopped) 1 = Launch PRNU calibration by setting it to "Once" (no effect if already launched)
FPNCalibrationCtrl	FPN calibration 0 = Abort FPN calibration by setting it to "Off" (no effect if already stopped) 1 = Launch FPN calibration by setting it to "Once" (no effect if already launched)

6.2.7.1 Automatic Calibration



Some Warnings can be issued from the PRNU/FPN Calibration Process as "pixel Overflow" or "Pixel Underflow" because some pixels have been detected as too high or too low in the source image to be corrected efficiently.

The Calculation result will be proposed anyway as it's just a warning message.

The Status Register is the changed and displayed in Device Control Status section.

6.2.7.2 Manual Flat Field Correction

The FFC Coefficients can also be processed outside of the Camera or changed manually by accessing directly their values in the Camera : This is the "Manual" FFC.

This will allow the user to upload/download out/in the Camera the FFC coefficients in/from a binary or text file that can be processed externally.

6.2.7.3 Save & Restore FFC

The new-processed FFC values can be saved or restored in/from 4 x User banks.

Both Gains and Offsets in the same time but also the FFC Adjust User target and associated gain.

These functions are available in the Flat Field correction/Save & Restore FFC section :

Feature	Description
FFCSetSelector	FFC bank selector
RestoreFFCFromBank	Restore current FFC (including FPN and FFCGain) from FFC bank number <val>, from 1 to 4; <val> comes from FFC SetSelector 0: Factory Bank 1,2,3,4: User Bank
SaveFFCToBank	Save current FFC (including FPN and FFCGain) to FFC bank number <val>, from 1 to 4; <val> comes from FFC SetSelector 1,2,3,4: User Bank



FFC User Bank Usage

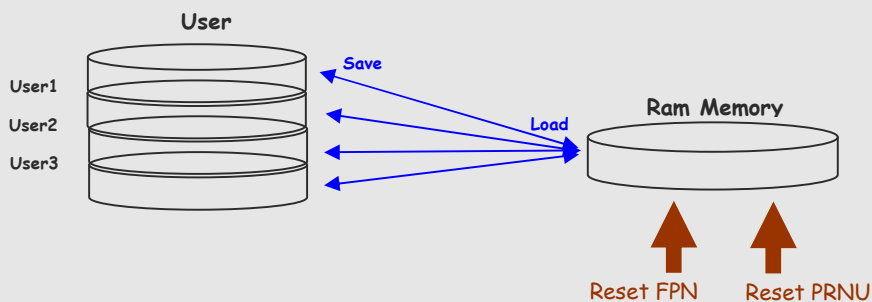

At the power up :
 - Last User Bank used is loaded in RAM
Reset a User bank :
 - Reset the RAM (FPN/PRNU individually)
 - Save in the bank to reset

6.2.8 Statistics and Line Profile

This function allows the User to get some statistics on a pre-defined ROI. On request, the Camera acquires and then calculates some key values as the min, the max, the average or the standard deviation in this Region of Interest.

The grab and calculation command and also the collection of the results is not performed in real time as it is done through the serial connection.

This function and the results are available in the "Line Profile Average" Section :

The Calculated values are detailed as following :

- **Pixel average Value** (*PixelROI*Mean) : Average gray level value calculated on whole Region of interest
- **Pixel Standard deviation** (*PixelROI*StandardDeviation) : standard deviation of all the pixel gray level values of Region of interest
- **Pixel Min value** (*PixelROI*Min) : Minimum gray level pixel value on the whole region of interest.
- **Pixel Max Value** (*PixelROI*Max) : Maximum gray level pixel value on the whole region of interest

Feature	Description
LineAverageProfile	Launches the Line Profile calculation on the selected ROI 0 = Abort the Line Average Profile 1 = Run the Line Average Profile
PixelAccessLineNumer	Set the number of line to accumulate - <val> : 1,256,512,1024
PixelRoiStart	Roi start for pixel statistic computing (0 to SensorWidth -1-1)
PixelRoiWidth	Roi width for pixel statistic computing (1 to SensorWidth)
For each color : Red, Blue, Green-red and Green-blue	
<i>Color</i> PixelROI	Get ROI Mean, Unsigned format value : U12.4
<i>Color</i> PixelROI	Get ROI Stand deviation, Unsigned format value : U12.4
<i>Color</i> PixelROI	Get ROI Min, Unsigned format value : U12.4
<i>Color</i> PixelROI	Get ROI Max , Unsigned format value : U12.4

6.2.9 Privilege Level

There are 3 privilege levels for the camera :

- Factory (0) : Reserved for the Factory
- Integrator (1) : Reserved for system integrators
- User (2) : For all Users.

The Cameras are delivered in Integrator mode. They can be locked in User mode and a specific password is required to switch back the Camera in Integrator mode. This password can be generated with a specific tool available from the hotline (hotline-cam@e2v.com)

Feature	Description
PrivilegeLevel	<p>Get camera running privilege level</p> <p>- In Read Mode:</p> <ul style="list-style-type: none"> 0 = Privilege Factory 1 = Privilege Advanced User 2 = Privilege User <p>- In Write Mode:</p> <ul style="list-style-type: none"> 1 = Lock camera o "Advanced User" 2 = Lock camera to "User" <p>other values = Unlock camera privilege depending on <val> (min=256; max=$2^{32}-1$)</p>

6.2.10 Save & Restore Settings

The settings (or Main configuration) of the Camera can be saved in 4x different User banks and one Integrator bank. This setting includes also the FFC and LUT enable parameters
 This function is available in the User Set Control section :

Feature	Description
UserSetSelector	User bank selector
UserSetLoad	Restore current UserSet from UserSet bank number <val>, from 0 to 5; <val> comes from UserSetSelector Default: Factory Bank User Set1, 2, 3, 4: User Banks User Set5: Integrator Bank
UserSetSave	Save current UserSet to UserSet bank number <val>, from 1 to 5; <val> comes from UserSetSelector User Set1, 2, 3, 4: User Bank User Set5: Integrator Bank (Not available in User Mode)



The integrator bank (User Set5) can be written only if the Camera is set in integrator mode (Privilege level = 1). This integrator bank can be used as a « Factory default » by a system integrator.



Configuration Bank Usage

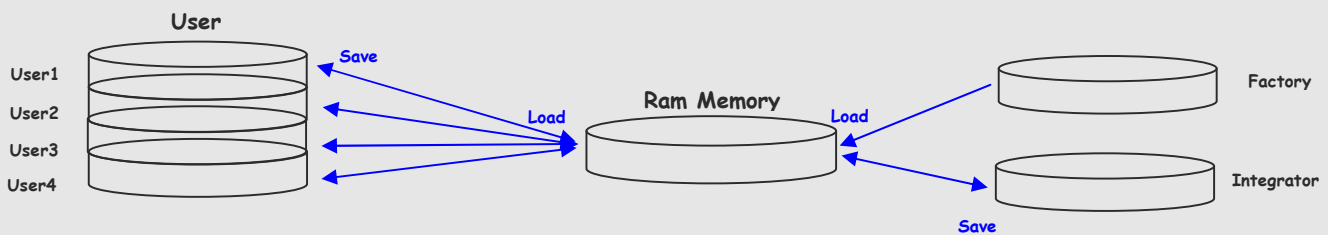

At the power up : Last User Bank used is loaded in RAM
 "Integrator" Bank (5) can be locked by switching the Camera in "User" mode (cf : Privilege feature).
 Then it can't be saved any more without switching back the Camera in "Integrator" Mode.

7 APPENDIX A: Test Patterns

7.1 Fixed Horizontal Ramps

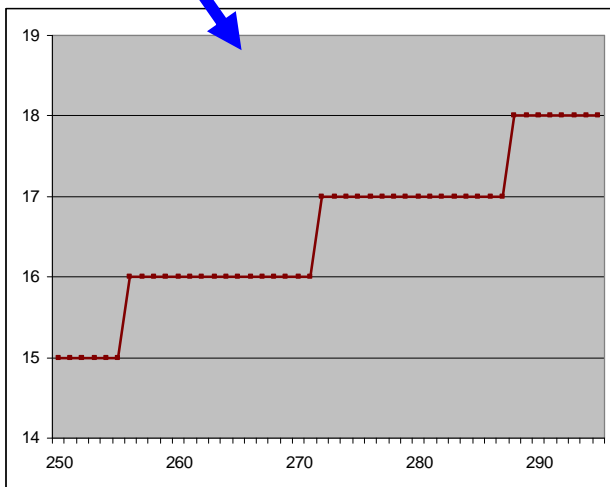
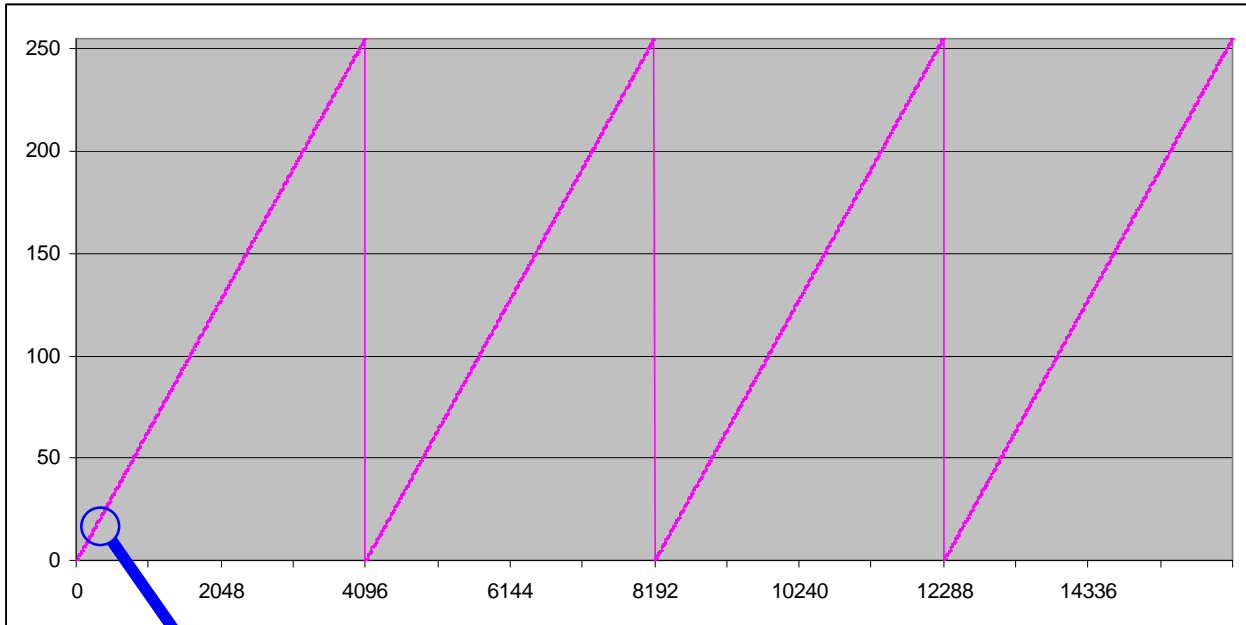

An increment of 1 LSB is made every 16 pixels
When it reaches 255, turns back to 0 and starts again

7.2 Color RGBW Fixed Pattern

This pattern is composed blocks of 512 pixels showing alternatively Red, Green, Blue and White colors :

Note : When the camera is set with this pattern test, it's no more taking in account the Line Trigger and working in Free Run (line period controlled by the camera)



7.3 Vertical wave

The Test pattern 1 is a vertical moving wave : each new line will increment of 1 gray level : Form 0 to 255 before switching down to 0 and increasing again.

8 APPENDIX B: Timing Diagrams

8.1 Synchronization Modes with Variable Exposure Time

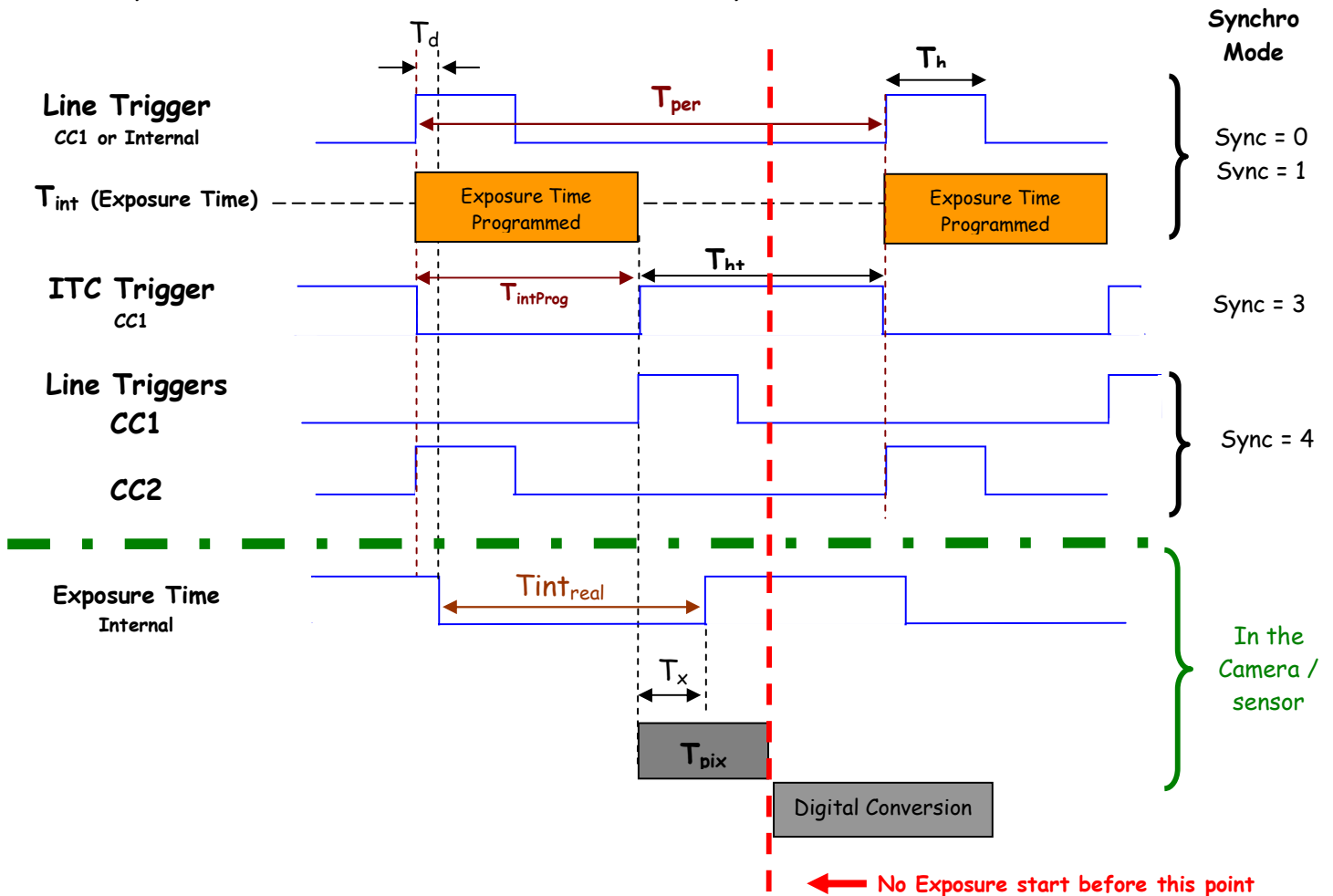

T_{pix} : Timing Pixel. During this uncompressible period, the pixel and its black reference are read out to the Digital converter. During the first half of this timing pixel (read out of the black reference), we can consider that the exposure is still active.

Digital Conversion : During the conversion, the analog Gain is applied by the gradient of the counting ramp (see next chapter : Gain & Offset). The conversion time depends on the pixel format :

- 8 or 10 bits : $6\mu s$
- 12 bits : $18\mu s$

This conversion is done in masked time, eventually during the next exposure period.

T_d : Delay between the Start exposure required and the real start of the exposure.



If T_{per} is the Line Period (internal or external coming from the Trigger line), in order to respect this line Period, the Exposure Time as to be set by respecting : $T_{int} + T_{pix} \leq T_{per}$
 Then, the real exposure time is : $T_{int_{real}} = T_{int} + T_x - T_d$
 In the same way, The high level period of the Trig signal in sync=3 mode, $T_{ht} \geq T_{pix}$

For a Line Period of $LinePer$, the maximum exposure time possible without reduction of line rate is : $T_{int_{max}} = T_{per} - T_{pix}$ (T_{pix} is defined above) but the effective Exposure Time will be about $T_{int_{real}} = T_{int} + T_x - T_d$

8.2 Synchronisation Modes with Maximum Exposure Time

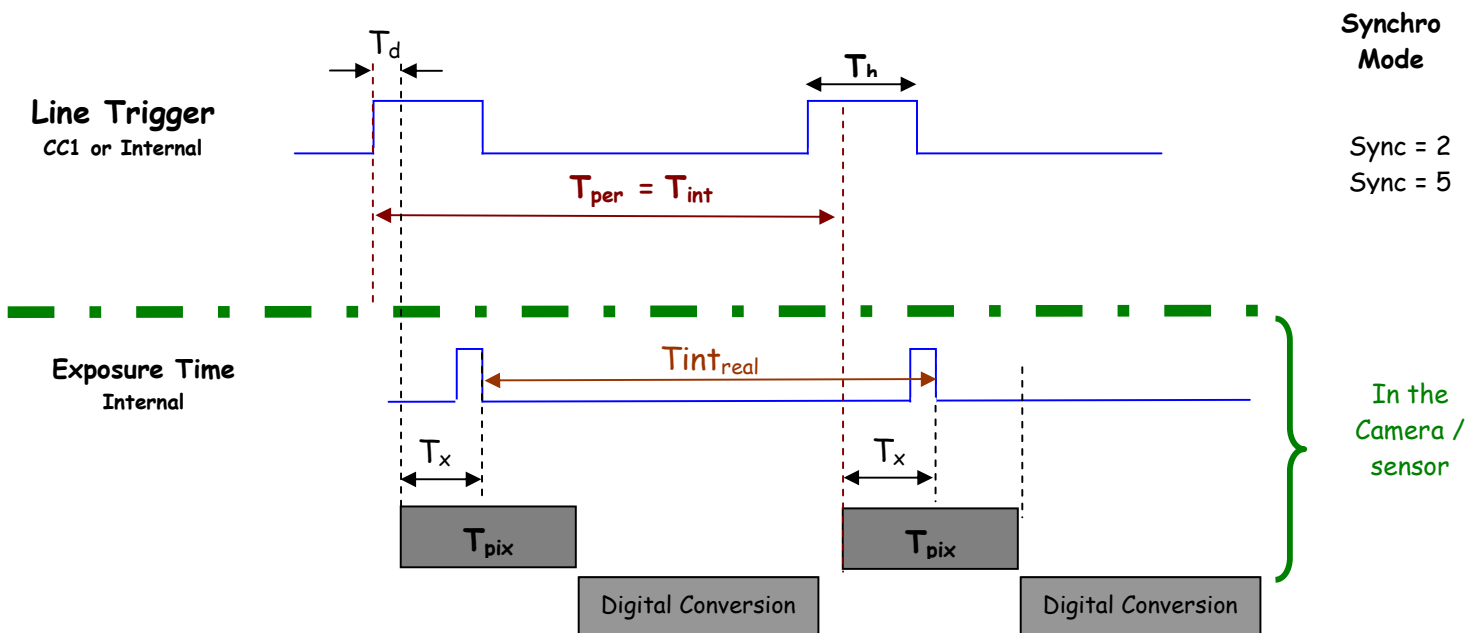

In these modes, the rising edge of the Trigger (internal or External) starts the readout process (T_{pix}) of the previous integration. The Real exposure time ($T_{int_{real}}$) is finally equal to the Line Period (T_{per}) even if it's delayed from ($T_x + T_d$) from the rising edge of the incoming Line Trigger.

8.3 Timing Values

Label	Min	Unit
T_{pix}	5	μS
T_x	3,1	μS
T_h	0,120	μS
T_{ht}	T_{pix}	μsec
T_d	1,1	μS

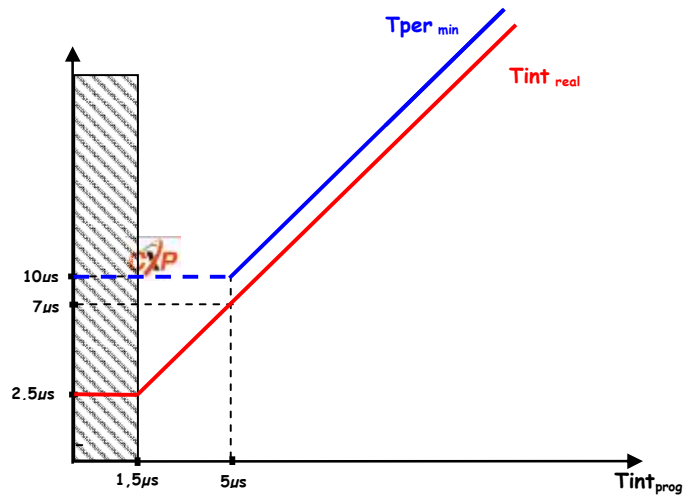

9 APPENDIX C: Data Cables

- CXP cables and the separate lanes of a CXP-multi-cable shall be coaxial with a characteristic impedance of $75\Omega \pm 4\Omega$. When a series connection of CXP-cables is considered, all of the BNC connectors used have to be of the 75Ω type, including any inline couplers.
- A CXP cable and the separate lanes of a CXP-multi-cable shall have a return loss better than or equal to :

• Frequency Range	• Return Loss
• 0-500MHz	• -20dB
• 500MHz - 3.2GHz	• -15dB

- The maximum length of a CoaXPress cable is the lowest figure from three different requirements: power supply voltage drop, high speed link requirements and low speed link requirements.
 - Power Supply Voltage Drop : A CXP cable and the separate lanes of a CXP multi-cable shall each have a total DC roundtrip resistance of less than 4.98Ω for each of the coax cables.
 - High Speed Link Requirement : A CXP cable and the separate lanes of a CXP-multi-cable that are specified for a given bit rate shall have an attenuation that is less or equal to the following attenuation at its corresponding frequency (example with Belden 1694A Cable) :

Bit Rate (Gbps)	Maximum Attenuation (dB)	@ Frequency (GHz)	Belden 1694A (m)
1.250	-21.2	0.625	130
2.500	-26	1.25	110
3.125	-26.8	1.5625	100
5.000	-20.9	2.5	60
6.250	-15.8	3.125	40

- Low Speed Link Requirement : A CXP cable and the separate lanes of a CXP-multi-cable shall have a signal attenuation at 30 MHz of less than, or equal to, -4.74dB.
- Cable Current Capacity : A CXP cable and the separate lanes of a CXP-multi-cable shall each be designed to carry 1A in normal operation.
- A CXP-cable and the separate lanes of a CXP-multi-cable shall have attenuation versus frequency characteristic exhibiting cable-like behaviour over the frequency ranges as indicated in the table below. A series connection of cables shall also fulfil this requirement as if it is one cable including all of its connectors and inline couplers.

Cable Rating (Gbps)	Frequency Range	
	From	To
1.250	1	0.625
2.500	1	1.25
3.125	1	1.5625
5.000	1	2.5
6.250	-15.8	3.125

10 APPENDIX D: Lenses Compatibility

QIOPTICS (LINOS)				
	Nominal Magnification	Magnification Range	M95 Focus tube Reference	Lens Reference Part number
Inspec.x. L 5.6/105	0,33 X	0,25 - 0,45 X	2408-012-000-41	0703-085-000-20
Inspec.x. L 5.6/105	0,5 X	0,4 - 0,65 X	2408-012-000-41	0703-084-000-20
Inspec.x. L 5.6/105	0,87 X	0,6 - 0,9 X	2408-012-000-43	0703-083-000-20
Inspec.x. L 5.6/105	1 X	0,85 - 1,2 X	2408-012-000-43	0703-082-000-20
Inspec.x. L 4/105	3 X	2,8 - 3,3 X	2408-012-000-46	0703-104-000-20
Inspec.x. L 4/105	3,5 X	3,3 - 3,7 X	2408-012-000-44	0703-095-000-21
Inspec.x. L 3.5/105	5 X	4,8 - 5,2 X	2408-012-000-45	0703-102-000-20
SCHNEIDER KREUZNACH				
	Nominal Magnification	Magnification Range	Working Distance (at nom. Mag.)	Reference Part number
SR 5.6/120-0058	1 X	0,88 - 1,13 X	212 mm	1002647
SR 5.6/120-0059	0,75 X	0,63 - 0,88 X	252 mm	1002648
SR 5.6/120-0060	0,5 X	0,38 - 0,63 X	333 mm	1002650
SR 5.6/120-0061	0,33 X	0,26 - 0,38 X	453 mm	1004611
Accessories	V mount 25mm macro-extension tube		Necessary to combine the whole lens system	20179
	V mount to Leica adapter			20054
	Unifoc 76			13048
	Adapter M58x0.75 - M95x1			1062891
	Extension tube M95x1, 25mm		To be combined to reach the appropriate magnification	1062892
	Extension tube M95x1, 50mm			1062893
	Extension tube M95x1, 100mm			1062894
MYUTRON				
	Nominal Magnification	Working Distance	M95 Custom Mount available Aperture (∞) : 4.7	
XLS03-E	x0,3	477mm		
XLS53-E	x0,5	324mm		
XLS75-E	x0,75	246mm		
XLS010-E	x1	197mm		
XLS014-E	x1,4	170mm		
XLS203-E	x2	146mm		

ELIIXA+® 16k/8k CXP Color

EDMUND OPTICS			
	Nominal Magnification	Working Distance	Reference
TechSpec F4	1 X	151 mm	NT68-222
TechSpec F4	1,33 X	158,5 mm	NT68-223
TechSpec F4	2,0 X	129 mm	NT68-224
TechSpec F4	3,0 X	110 mm	NT68-225
Accessories	Large Format Tip/Tilt Bolt Pattern Adapter, 2X		NT69-235
	Large Format Focusing Module		NT69-240
	Large Format Adapter Set		NT69-241
NAVITAR			
Raptar Pro 4/86	1 X	Extension Tubes on request	1 - 17494
NIKON			
Rayfact F4	0,05 X - 0,5 X	1820,4mm - 230,3mm	Rayfact ML90mm F4

11 Frame Grabbers Compliance

Brand	F.G. Name	Detailed Reference	e2v tested
Active Silicon	FireBird CoaXPress	FBD-4XCXP6 in PCIe x8 (Gen2)	OK
Bitflow	Karbon CoaXPress	KBN-PCE-CXP4	On testing
	Cyton CoaXPress	Cyton-CXP4	To be tested
Matrox	Radiant CoaXPress	Radiant eV-CXP	OK
Silicon Software	MicroEnable 5	AQ8-CXP6B	OK

12 APPENDIX E: COMMANDS SUMMARY

12.1 Category "Device Control"

Feature	CXP @	Size in bytes	Description	By default
DeviceVendorName	0x02000 Bootstrap	32	Get camera vendor name as a string (including '\0')	"e2v"
DeviceModelName	0x02020 Bootstrap	32	Get camera model name as a string (including '\0')	See R5 document
DeviceFirmwareVersion	0x02090 Bootstrap	32	Get camera synthetic firmware version (PKG version) as a string (including '\0')	"1.0.0"
DeviceVersion	0x02070 Bootstrap	32	Get camera version as a string (hardware version) (including '\0')	""; to update by test bench
DeviceManufacturerInfo	0x02040 Bootstrap	48	Get camera ID as a string (including '\0')	""; to update by test bench
DeviceUserID	0x020C0 Bootstrap	16	Get device user identifier as a string (including '\0')	"camera identification for user purpose"
DeviceID	0x020B0 Bootstrap	16	Read Serial Nb	""; to update by test bench
ElectronicBoardID	0x08000	32	Read Electronic Board ID	""; to update by test bench
ElectronicBoardTestStatus	0x08020	16	Read Electronic board status	"" to update by test bench
DeviceSFNCVersionMajor	Xml			1
DeviceSFNCVersionMinor	Xml			5
DeviceSFNCVersionSubMinor	Xml			0

12.2 Image Format

Feature	CXP @	Size in bytes	Description	By default
Width	0x07000	4	Depends on SensorWidth	
Height	0x07004	4		
AcquisitionMode	0x07008		1: Continuous	
AcquisitionStart	0x0700C		0: Start the acquisition	
AcquisitionStop	0x07010		0: Stop the acquisition	
PixelFormat	0x07014	4	0x0401: RGB Mono8	0
SensorWidth	0x08200	4	Get sensor physical width.	Given by the sensor
SensorHeight	Xml			
WidthMax	Map on SensorWidth			Value of SensorWidth
HeightMax	Xml			
SensorMode	0x08204	4	0 : True Color Mode (8192 pixels outputted) 1 : Full Definition Single Mode (16386 Pixels Outputted) 2 : Full Definition Enhanced Mode (16386 Pixels Outputted)	1

ELIIXA+® 16k/8k CXP Color

Feature	CXP @	Size in bytes	Description	By default
MultiLineGain	0x08208	4	0: Set MultiLine gain to "x1" 1: Set MultiLine gain to "x1/2" : not available if SensorMode = 0 ("1S" mode)	0
ReverseReading	0x08210	4	0: Set reverse reading to "disable" 1: Set reverse reading to "enable"	0
TestImageSelector	0x08214	4	0: Set test (output FPGA) image pattern to "Off", processing chain activated 1: Set test (output FPGA) image pattern to "GreyHorizontalRamp", processing chain disabled 2: Set test (output FPGA) image pattern to "White pattern", processing chain disabled 3: Set test (output FPGA) image pattern to "gray pattern", processing chain disabled 4: Set test (output FPGA) image pattern to "Black pattern", processing chain disabled 5: Set test (output FPGA) image pattern to "GreyVerticalRampMoving", processing chain disabled	0
InputSource	0x08218	4	0: Set signal source to CMOS sensor, processing chain activated	0
Color Selection	0x08230	4	Disable color components Bit 0 : Disable Red color Bit 1 : Disable Blue color Bit 2 : Disable Green colors (both Green _{Red} and Green _{Blue})	

12.3 Synchro and Acquisition modes

Feature	CXP @	Size in bytes	Description	By default
LinePeriod	0x08400	4	Set line period, from from 1 (0,1 μ s) to 65535 (6553,5 μ s), step 1 (0,1 μ s)	500
LinePeriodMin	0x08404	4	Get current line period min (0..65535 step 0,1 μ s)	Depends on Sensor mode
AcquisitionLineRate	Xml		= 1 / LinePeriod en Hertz	
ExposureTime	0x08408	4	Set exposure time, from 1 (0,1 μ s) to 65535 (6553,5 μ s), step 1 (0,1 μ s)	500
TriggerPreset	0x0840C	4	0: Set trigger preset mode to Free run timed mode, with exposure time and line period programmable d 1: Set trigger preset mode to Triggered mode with exposure time settings 2: Set trigger preset mode to Triggered mode with maximum exposure time 3: Set trigger preset mode to Triggered mode with exposure time controlled by one signal 4: Set trigger preset mode to Triggered mode with exposure time controlled by two signals 5: Set trigger preset mode to Freerun mode, with max exposure time and programmable line period	5

12.4 Scan Direction

Feature	CXP @	Size in bytes	Description	By default
ScanDirectionMode	0x0820C	4	0: Set scan direction to "forward" 1: Set scan direction to "reverse" 2: Set scan direction to "Externally controlled direction via External Line on I/O Connector (0 : forward, 1 : reverse)	0
ExternalLine	0x08570	4	0: Line0 1: Line1	0

12.5 GenICam Trigger

Feature Name	CXP @	Size bytes	Bit field	Description	By default
ExposureMode	0x08414	4	[31-30]	Operation mode for the exposure control: 0: Off 1: Timed 2: TriggerWidth 3: TriggerControlled	Timed
TriggerSelector	Not a register			Select the trigger to control { ExposureStart, ExposureEnd, ExposureActive}	ExposureStart
TriggerSelector = ExposureActive					
TriggerMode	0x08420	4	[31]	Specifies the operation mode of the trigger for the acquisition : 0: Off 1: On	Off
TriggerSource			[30-26]	Specifies the source for the trigger : 0: Software 1: Line0 2: Line1 3: Line2 4: TimerStart1 5: TimerStart2 6: TimerEnd1 7: TimerEnd2 8: CounterStart1 9: CounterStart2 10: CounterEnd1 11: CounterEnd2 17: Line0 OR line1 18: Line0 AND Line1 19: RescalerLine	Software
TriggerActivation			[25-23]	Specifies the activation mode of the trigger : 0: RisingEdge 1: FallingEdge 2: AnyEdge, 3: LevelHigh 4: LevelLow	RisingEdge
TriggerDelayAbs			[20-16]	Specifies the absolute delay in μs to apply after the trigger reception before effectively activating it (0,31/30MHz,step 1/30MHz μs)	

ELIIXA+® 16k/8k CXP Color

Feature Name	CXP @	Size bytes	Bit field	Description	By default
TriggerSoftware	0x08424	4		Generate a software trigger to start the acquisition when trigger mode is active and trigger source is software	
TriggerSelector = ExposureEnd					
TriggerMode, ...	0x08430	4		Same as above	
TriggerSoftware	0x08434	4			
TriggerSelector = ExposureStart					
TriggerMode, ...	0x08440	4		Same as above	
TriggerSoftware	0x08444	4			

12.6 Digital IO Control

Feature Name	CXP @	Size bytes	Bit field	Description	By default
LineStatusAll	0x08460	4		Return the current status of all lines (bit0 for Line0, bit1 for Line1, bit2 for Line2)	
LineSelector	Not a register			Select which physical line of the external device connector to configure {Line0, Line1, Line2 }	Line0
LineSelector = Line0					
LineMode	0x08470	4	[31]	Define the physical line as input {Input} 0: Input 1: Output	Input
LineInverter			[30]	Define the signal inversion: 0: False 1: True	False
LineDebounceFilter			[29]	Activate debounce filter {True, False}	False
LineStatus			[28]	Return the current status of the selected : 0: False 1: True	
LineFormat			[25-24]	Select the electrical format of the selected line (line0 or line1): 0: TTL 1: LVDS 2: RS422	TTL
LineSelector = Line1					
LineMode	0x08480			Same as above	
LineInverter				Same as above	
LineDebounceFilter				Same as above	
LineStatus				Same as above	
LineFormat				Same as above	
LineSelector = Line2					
LineMode	0x08490			Same as above	
LineInverter				Same as above	
LineDebounceFilter				Same as above	
LineStatus				Same as above	
LineFormat				Same as above	

12.7 Counters

Feature Name	CXP @	Size bytes	Bit field	Description	By default
CounterSelector	Not a register			Select which counter to configure {Counter1, Counter2}	Counter1
CounterSelector = Counter1					
CounterTriggerSource	0x084B0	4	[31-27]	Select the signal that start (reset) the counter: 0: Off 9: ExposureStart 10: ExposureEnd 11: Line0 12: Line1 13: Line2 16: Counter1End 17: Counter2End 18: Timer1End 19: Timer2End	
CounterTriggerActivation			[26-24]	Select the type of activation for the trigger to start (reset) the counter : 0: RisingEdge 1: FallingEdge 2: AnyEdge, 3: LevelHigh 4: LevelLow	RisingEdge
CounterEventSource			[23-19]	Select the event that will be the source to increment the counter : 0: Off 9: ExposureStart 10: ExposureEnd 11: Line0 12: Line1 13: Line2 16: Counter1End 17: Counter2End 18: Timer1End 19: Timer2End 20: TimeStampTick 21: MissedTrigger	Off
CounterEventActivation			[18-16]	Select the type of activation for the event that increment the counter : 0: RisingEdge 1: FallingEdge 2: AnyEdge, 3: LevelHigh 4: LevelLow	RisingEdge
CounterStatus			[15-13]	Get counter status : 0: CounterIdle 1: CounterTriggerWait 2: CounterActive, 3: CounterCompleted 4: CounterOverflow	
CounterDuration	0x084B4	4	[31-0]	Set the counter duration (or number of events) before CounterEnd event is generated	100
CounterReset	0x084B8	4		Reset the selected counter	
CounterValue	0x084BC	4	[31-0]	Read the current value of the selected counter	
CounterValueAtReset	0x084C0	4	[31-0]	Read the value of the selected counter, when the counter was reset by a trigger or by an explicit CounterReset.	

ELIIXA+® 16k/8k CXP Color

Feature Name	CXP @	Size bytes	Bit field	Description	By default
CounterResetSource	0x084C4	4	[31-27]	Select the signal that reset the counter: 0: Off 1: Software 2: Line0, 3: Line1 4: Line2	
CounterResetActivation			[26-24]	Select the type of activation for the counter reset source : 0: RisingEdge 1: FallingEdge 2: AnyEdge, 3: LevelHigh 4: LevelLow	RisingEdge
CounterSelector = Counter2					
CounterTriggerSource	0x084D0	4		Same as above	
CounterTriggerActivation				Same as above	
CounterEventSource				Same as above	
CounterEventActivation				Same as above	
CounterStatus				Same as above	
CounterDuration	0x084D4	4		Same as above	
CounterReset	0x084D8	4		Same as above	
CounterValue	0x084DC	4		Same as above	
CounterValueAtReset	0x084E0	4		Same as above	
CounterResetSource	0x084E4	4		Same as above	
CounterResetActivation				Same as above	

12.8 Timers

Feature Name	CXP @	Size bytes	Bit field	Description	By default
TimerSelector	Not a register			Select which timer to configure {Timer1, Timer2}	Timer1
TimerSelector = Timer1					
TimerTriggerSource	0x08500	4	[31-27]	Select which internal signal will trigger the timer: 0: Off 9: ExposureStart 10: ExposureEnd 11: Line0 12: Line1 13: Line2 16: Counter1End 17: Counter2End 18: Timer1End 19: Timer2End	Off
TimerTriggerActivation			[26-24]	Select the type of signal that will trig the timer: 0: RisingEdge 1: FallingEdge 2: AnyEdge, 3: LevelHigh 4: LevelLow	RisingEdge
TimerDelay			[23-19]	Set the delay in μ s from the TimerTrigger to the actual Timer pulse output ((0,31/30MHz, step 1/30MHz)	0
TimerStatus			[18-17]	Get counter status 0: TimerIdle 1: TimerTriggerWait 2: TimerActive, 3: TimerCompleted	
TimerDuration	0x08504	4	[31-0]	Set the length of the ouput pulse in μ s (0,6553.5, step 0.1)	100
TimerValue	0x08508	4	[31-0]	Return the actual value of the selected timer (0,65535/30MHz, step 1/30MHz)	
TimerSelector = Timer2					
TimerTriggerSource	0x08510	4		Same as above	
TimerTriggerActivation				Same as above	
TimerDuration	0x08514	4		Same as above	
TimerDelay				Same as above	
TimerValue	0x08518	4		Same as above	

12.9 Rescaler

Feature Name	CXP @	Size bytes	Bit field	Description	By default
TriggerRescalerSource	0x08540	4	[31-30]	RescalerSize (see 6.2.3.4) Bit0: 0: line0 selected for rescaler 1: line1 selected for rescaler Bit1: Bypass Rescaler	
TriggerRescalerMultiplier			[29-18]	mult factor for rescaler function Rescaler will create "mult" pulse between input trig	
TriggerRescalerDivider			[17-6]	div factor for rescaler function Rescaler will take 1 pulse each "div" pulse	
TriggerRescalerGranularity			[5-4]	0: 1 *20 = 20 ns 1: 4 *20 = 80 ns 2: 16 *20 = 320 ns 3: 256 *20 = 5120 ns	
TriggerRescalerCountInt	0x08544		[31-16]	count_int overflow	
TriggerRescalerCountIntOverflow			[15]	count_int counter of rescaler bloc count between 2 input trig	

12.10 Gain & Offset

Feature	CXP @	Size in bytes	Description	By default
GainAbs GainSelector= AnalogAll	0x08600	4	Set pre amplifier gain to: 0: (-12dB) 1: (-6dB) 2: (0dB) (analog gain) Change balances and compensation	0
GainAbs GainSelector= gainAll	0x08604	4	Set gain from 0dB(0) to +8 dB (6193)	0
Gain Abs GainSelector=DigitalAll	0x08608	4	Set contrast expansion digital gain from 0 (0 dB) to 255 (+14 dB), step 1 (TBD dB)	0
BlackLevelRaw BlackLevelSelector=All	0x0860C	4	Set common black from -4096 to 4095, step 1	0
GainAbs GainSelector=QuarterGain<j>	0x08610 to 0x0861C	4 * 4	tap<j> digital gain from -128 to 127 by step 1 (0.0021dB). Dynamically updated on AnalogAll gain changes	0
Gain GainSelector=DigitalRed	0x08630	4	Set gain for Red color form 0 (0db) to 6193 (8dB) Used for White balance	0
Gain GainSelector=DigitalBlue	0x08634	4	Set gain for Blue color form 0 (0db) to 6193 (8dB) Used for white balance	0
Gain GainSelector=DigitalGreen(red)	0x08638	4	Set gain for Green Red color form 0 (0db) to 6193 (8dB) Used for white balance	0
Gain GainSelector=DigitalGreen(blue)	0x0863c	4	Set gain for Green Blue color form 0 (0db) to 6193 (8dB) Used for white balance	0
AutoWhiteBalance Start	0x8640	4	Auto White Balance controle 0 - Abort Auto White Balance 1 - Start Auto White Balance	-
AutoWhiteBalance Status	0x8644	4	Auto White Balance Status	-
White Balance Enable	0x8648	4	0 : disable White Balance 1: Enable White Balance	0

12.11 Flat Field Correction

Feature	CXP @	Size in bytes	Description	By default
FFCEnable	0x08800	4	0: Disable Flat Field Correction ("False") - In user/integrator mode : the factory FFC bank is written into the FPGA and the FFC stays enabled 1: Enable Flat Field Correction ("True")	0
FPNReset	0x08804	4	0: Reset FPN coefficients	
PRNUReset	0x08808	4	0: Reset PRNU coefficients	
FPNValueAll	0x10000	32K	Memory containing FPN Format: S9.1 => -256..+255.5 step ½ Size=CCDSize*2	
FPNValueSize	Xml	2	Integer providing FPN value size in byte	
PRNUValueAll	0x20000	32K	Memory containing PRNU Format: U1.13 (1+coeff/1024) => x1..x4.999877 step 1/1024 Size=CCDSize*2	
PRNUValueSize	Xml	2	Integer providing PRNU value size in byte	
FFCCalibrationCtrl	0x0880C	4	FFC calibration - In Read Mode: 0 = finished 1 = running - In Write Mode: 0 = Abort PRNU calibration by setting it to "Off" (no effect if already stopped) 1 = Launch PRNU calibration by setting it to "Once" (no effect if already launched)	0
FPNCalibrationCtrl	0x08810	4	FPN calibration - In Read Mode: 0 = finished 1 = running - In Write Mode: 0 = Abort FPN calibration by setting it to "Off" (no effect if already stopped) 1 = Launch FPN calibration by setting it to "Once" (no effect if already launched)	0
FFCAadjust	0x08814	4	0: Disable ffc adjust 1: Enable ffc adjust	0
FFCAutoTargetLevel	0x08818	4	Set FFC target adjust level, from 0 to 4095, step 1	3000
FFCGainAdjust	0x0881C	4	FFC Gain Adjust	

12.12 Save and restore User Configurations

Feature	CXP @	Size in bytes	Description	By default
UserSetLoad	0x08C00	4	Restore current UserSet from UserSet bank number <val>, from 0 to 5; <val> comes from UserSetSelector 0: Factory Bank 1,2,3,4: User Bank 5: Integrator Bank	0
UserSetSave	0x08C04	4	Save current UserSet to UserSet bank number <val>, from 1 to 5; <val> comes from UserSetSelector 1,2,3,4: User Bank 5: Integrator Bank (Not available in User Mode)	
UserSetControl	Xml		User bank selector	
RestoreLUTFromBank	0x08C08	4	Restore current LUT from LUT bank number <val>, from 1 to 4; <val> comes from LUTSetSelector 1,2,3,4: User Bank	1
SaveLUTToBank	0x08C0C	4	Save current LUT to LUT bank number <val>, from 1 to 4; <val> comes from LUTSetSelector 1,2,3,4: User Bank	
LUTSetSelector	Xml		LUT bank selector	
RestoreFFCFromBank	0x08C10	4	Restore current FFC (including FPN and FFCGain) from FFC bank number <val>, from 1 to 4; <val> comes from FFC SetSelector 1,2,3,4: User Bank	1
SaveFFCToBank	0x08C14	4	Save current FFC (including FPN and FFCGain) to FFC bank number <val>, from 1 to 4; <val> comes from FFC SetSelector 1,2,3,4: User Bank	
FFCSetSelector	Xml		FFC bank selector	

12.13 Camera Status

Feature	CXP @	Size in bytes	Description	By default
PrivilegeLevel	0x08E00	4	Get camera running privilege level - In Read Mode: 0 = Privilege Factory 1 = Privilege Advanced User 2 = Privilege User - In Write Mode: 1 = Lock camera o "Advanced User" 2 = Lock camera to "User" other values = Unlock camera privilege depending on <val> (min=256; max=2 ³² -1)	NA
DeviceTemperature	0x08E04	4	Read Main board internal temperature (format signed Q10.2 = signed 8 bits, plus 2 bits below comma. Value from -512 to +511) in °C	
DeviceTemperatureSelector	Xml		Device Temperature selector	
Standby	0x08E08	4	0 :Disable standby mode ("False") 1 :Enable standby mode ("True"), no more video available but save power and temperature	0

ELIIXA+® 16k/8k CXP Color

StatusWaitForTrigger	0x08E0C	4	Bit 0: true if camera waits for a trigger during more than 1s	
Status trigger too fast			Bit 1: true if camera trigger is too fast	
StatusSensorConnexion			Bit 2: true if sensor pattern checking has failed	
Status3V7			Bit 3: true if 3V7 failure	
Status3V3			Bit 4: true if 3V3 failure	
Status1V0			Bit 5: true if 1V0 failure	
Status1V8			Bit 6: true if 1V8 failure	
Status1V8ANA			Bit 7: true if 1V8ANA failure	
StatusWarningOverflow			Bit 8: true if a an overflow occurs during FFC calibration or Tap balance (available only for integrator/user mode)	
StatusWarningUnderflow			Bit 9: true if a an underflow occurs during FFC calibration or Tap balance (available only for integrator/user mode)	
Status2V5			Bit 10: true if 2V5 failure	
CC3 Scrolling direction			Bit 11: 0 : forward, 1: reverse	
StatusErrorHardware			Bit 16 : true if hardware error detected	

12.14 Line Profile Average

Feature	CXP @	Size in bytes	Description	By default
LineAverageProfile	0x09000	4	Camera running privilege level - In Read Mode: 0 = finished 1 = running - In Write Mode: 0 = Abort the Line Average Profile 1 = Run the Line Average Profile	0
PixelAccessLineNumer	0x09004	4	Set the number of line to accumulate - <val> : 1,256,512,1024	1
PixelValueAll	0x40000	32K	Pixel Values Size=SensorWidth * 2	
PixelRoiStart	0x09008	4	Roi start for pixel statistic computing (0 to SensorWidth -1-1)	0
PixelRoiWidth	0x0900C	4	Roi width for pixel statistic computing (1 to SensorWidth)	SensorWidth
PixelROI Mean	0x09010	4	Get ROI Mean (format U12.4)	0
PixelROI StandardDeviation	0x09014	4	Get ROI Stand deviation (format U12.4)	0
PixelROI Min	0x09018	4	Get ROI Min (format U12.4)	0
PixelROI Max	0x0901C	4	Get ROI Max (format U12.4)	0

13 APPENDIX F: Revision History

Manual Revision	Comments / Details	Firmware version
Rev A	First release	1.0.4

ELIIXA+® 16k/8k CXP Color

e2v.com/imaging

For details of our global offices please visit
e2v.com

Contact us online at:
e2v.com/contact

Issue 3 10/12



Whilst e2v has taken care to ensure the accuracy of the information contained herein it accepts no responsibility for the consequences of any use thereof and also reserves the right to change the specification of goods without notice. e2v accepts no liability beyond that set out in its standard conditions of sale in respect of infringement of third party patents arising from the use of tubes or other devices in accordance with information contained herein.