

**BRINGING
YOUR SORTING
EQUIPMENT
TO THE
NEXT LEVEL**



USER MANUAL

UNiiQA+ COLOR

[e2v.com/imaging](https://www.e2v.com/imaging)

WE PARTNER WITH OUR CUSTOMERS TO IMPROVE, SAVE AND PROTECT PEOPLE'S LIVES



Table of Contents

1	Camera Overview	5
1.1	Features	5
1.1	Key Specifications	5
1.2	Description.....	6
1.3	Typical Applications	6
1.4	Models	7
2	Camera Performances	7
2.1	Camera Characterization	7
2.2	Image Sensor	8
2.2.1	4k pixels 5x5 μ m (Full Definition)	8
2.2.2	2k, 1k or 512 pixels 10x10 μ m (True Color)	8
2.2.3	Column Interpolation	9
2.2.4	Line Interpolation	9
2.2.5	Effects of the interpolations	10
2.3	Response & QE curves	11
2.3.1	Quantum Efficiency	11
2.3.2	Spectral Response Curve	11
3	Camera Hardware and Interface	12
3.1	Mechanical Drawings.....	12
3.2	Input/output Connectors and LED	13
3.2.1	Power Connector	14
3.2.2	Consumption and Inrush Current	14
3.2.3	Status LED Behaviour.....	15
3.2.4	CameraLink Output Configuration.....	15
4	Standard Conformity	16
4.1	CE Conformity	16
4.2	FCC Conformity	16
4.3	RoHS / Chinese RoHS	16
4.4	GenICam / GenCP	16
5	Getting Started.....	17
5.1	Out of the box.....	17

5.2	Setting up in the system	17
6	Camera Software Interface	18
6.1	Control and Interface	18
6.2	Serial Protocol and Command Format	19
6.2.1	Syntax.....	19
6.2.2	Command Processing.....	19
6.2.3	GenCP Compliance	19
6.2.4	Error code table	20
7	Camera Commands	21
7.1	Device Information	21
7.2	Device Privilege, Standby, Status and Reboot.....	22
7.3	Communication and Firmware version	23
7.4	Image Format	24
7.5	Acquisition Control	28
7.6	Gains and Offsets.....	30
7.7	Color Management.....	32
7.8	Flat Field Correction	35
7.8.1	Automatic Calibration.....	36
7.8.2	Manual Flat Field Correction	40
7.9	Save & Restore FFC and Configuration User set.....	42
7.9.1	Save & Restore FFC.....	42
7.9.2	Save & Restore Settings.....	43
	APPENDIX	44
	Appendix A. Test Patterns	45
A.1	4k Pixels, 12bits	45
A.2	2k Pixels, 12bits	45
A.3	1k Pixels, 12bits	45
A.4	1k Pixels, 12bits	46
	Appendix B. Timing Diagrams	47
B.1	Synchronization Modes with Variable Exposure Time.....	47
B.2	Synchronisation Modes with Maximum Exposure Time.....	48
B.3	Timing Values	49
	Appendix C. CameraLink Data Cables.....	50
C.1	Choosing the Cable.....	50

C.2 Choosing the Data Rate	51
C.2.1 High Speed Models.....	51
C.2.2 Essential Models.....	52
Appendix D. Lens Mounts.....	53
D.1 F-Mount.....	53
D.2 C-Mount	54
Appendix E. CommCam Connection.....	55
Appendix F. Revision History	57

1 Camera Overview

1.1 Features

- CMOS Color LineScan Sensors:
 - 4096 pixels, 5x5µm
 - 2048, 1024 or 512 pixels, 10x10µm
- Interface : CameraLink® (Base or Medium)
- Line Rate :
 - Up to 40 kl/s for the Base Version
 - Up to 100 kl/s for the High-Speed Version
 - Data Rate : 42.5MHz, 60MHz and 85MHz
 - Bit Depth : 24 bits RGB
 - Flat Field Correction
 - Contrast Expansion
 - Power Supply : 10 – 15V. PoCI Compliant.
 - Low Power Consumption : < 3.5W
 - M42x1 Native and F-Mount, C-Mount adapters available
 - GenCP Compliant (xml file embedded)

1.1 Key Specifications

Note : All values in LSB are given in 8 bits format

Characteristics	Typical Value				Unit
Sensor Characteristics at Maximum Pixel Rate					
Resolution	4096	2048	1024	512	Pixels
pixel size (square)	5 x 5	10 x 10	10 x 10	10 x 10	µm
Max Line Rate (Essential Version)					
CameraLink Base (1 x RGB channel at 85MHz)	20	40	40	40	kHz
Max Line Rate (High Speed version)					
CameraLink® Base (1 x RGB channel at 85MHz)	20	40	80	80	kHz
CameraLink® Medium (2 x RGB channels at 85MHz)	40	80	100	100	kHz
Radiometric Performance at Maximum Pixel Rate and minimum camera gain					
Bit depth	24 RGB				Bits
Peak Response (B/G/R)	2.8 / 3.8 / 4.1				LSB _{8bits} /(nJ/cm ²)
Camera Gain	1.1 ^(*)				e-/LSB _{12bits}
Full Well Capacity	23,7 ^(*)				Ke-
Response non linearity (Max)	1				%
Readout Noise	7,5 ^(*)				e-
Dynamic range	56				dB
SNR Max (3/4 Sat)	39.5				dB
PRNU HF Max	3				%

^(*) Values per ADC (per color)

Functionality (Programmable via Control Interface)		
Analog Gain	Up to 12 (x4)	dB
Offset	-4096 to +4096	LSB
Trigger Mode	Timed (Free run) and triggered (Ext Trig, Ext ITC) modes	
Mechanical and Electrical Interface		
Size (w x h x l)	60 x 60 x 33.65	mm
Weight	<150	g
Lens Mount	F, C and M42x1 (on the Front Face)	-
Sensor alignment (see chapter 2.1)	±100	µm
Sensor flatness	50	µm
Power supply	Single 10 DC to 15 DC	V
Power dissipation	< 3,6 (PoCL compliant)	W
General Features		
Operating temperature	0 to 50 (front face), 70 (internal)	°C
Relative Humidity for Operation	85%	%
Storage temperature	-40 to 70	°C
Regulatory	CE, FCC , Reach, RoHS and Chinese RoHs compliant	

1.2 Description

e2v's UNiiQA+ line scan cameras family has been specifically designed to overcome the limitations of your current inspection system: make cost savings, improve your throughput, inspect larger areas or identify smaller defects.

Three UNiiQA+ product ranges are offered:

- UNiiQA+ Essential: low speed cameras for cost effective equipment or with modest speed requirement
- UNiiQA+ High-Speed: high speed cameras to help improve the performance of your system

The UNiiQA+ family has also been designed to be highly modular to enable engineers to reuse the same camera in multiple equipment, simplify logistics and reduce development cycle time. All UNiiQA+ cameras feature e2v's proprietary CMOS sensors : a single line of highly sensitive pixels of either 5µm or 10µm size.

1.3 Typical Applications

- On-line quality control
 - Raw material inspection (plastic film, glass, wood...)
 - Print and paper inspection
- Sorting
 - Food sorting (Belt sorting, Lane sorting, Free fall sorting)
 - Parcel and postal sorting
 - Barcode reading

1.4 Models

	Camera Part Number	Description	Details
UNIIQA+ Essential	EV71YC1CCL4005-BA2	Versatile Base CameraLink	4k pixels 5x5µm up to 20kHz 2k, 1k and 0,5k pixels 10x10µm up to 40kHz
	EV71YC1CCL4005-BA0	4k Pixels Base CameraLink	4k pixels 5x5µm up to 20kHz
	EV71YC1CCL2010-BA0	2k pixels Base CameraLink	2k pixels 10x10µm up to 40kHz
UNIIQA+ High Speed	EV71YC1CCL4005-BA3	Versatile Full CameraLink	4k pixels 5x5µm up to 40kHz 2k, 1k and 0,5k pixels 10x10µm up to 80kHz
	EV71YC1CCL4005-BA1	4k Pixels Full CameraLink	4k pixels 5x5µm up to 40kHz
	EV71YC1CCL2010-BA1	2k pixels Full CameraLink	2k pixels 10x10µm up to 80kHz

2 Camera Performances

2.1 Camera Characterization

	Unit	4k x 5µm		2k x 10µm		1k x 10µm		0,5k x 10µm	
		Typ.	Max	Typ.	Max	Typ.	Max	Typ.	Max
Dark Noise RMS	LSB _{8bits}	0.43	0.8	0.45	0.8	0.45	0.8	0.45	0.8
Dynamic Range	dB	56	-	55	-	55	-	55	-
Readout Noise	e-	7.5	-	7.5	-	7.5	-	7.5	-
Full Well Capacity	Ke-	23.7 ^(*)	-	23.7 ^(*)	-	23.7 ^(*)	-	23.7 ^(*)	-
SNR (3/4 Sat)	dB	39.5	-	39.5	-	39.5	-	39.5	-
Peak Response	LSB _{8bits} / (nJ/cm ²)	2.8/3.8/4.1 ^(**)	-	2.8/3.8/4.1 ^(**)	-	2.8/3.8/4.1 ^(**)	-	2.8/3.8/4.1 ^(**)	-
Non Linearity	%	-	1	-	1	-	1	-	1
Without Flat Field Correction :									
FPN rms	LSB	0.22	1	0.22	1	0.22	1	0.22	1
FPN pk-pk	LSB	0.99	2	0.99	2	0.99	2	0.99	2
PRNU hf (3/4 Sat)	%	0.13	1	0.13	1	0.13	1	0.13	1
PRNU pk-pk (3/4 Sat)	%	0.96	3	0.96	3	0.96	3	0.96	3

Test conditions and notes :

- ^(*) Values per ADC (per color)
- ^(**) Blue/Green/Red in LSB_{8bits}/(nJ/cm²)
- Figures in LSB are for a 8bits format.
- Measured at Max Exposure Time and Nominal Gain (No Gain)
- Maximum data rate
- Stabilized temperature 30/40/55 °C (Room/Front Face/Internal)
- SNR Calculated at 75% Saturation with minimum Gain.

2.2 Image Sensor

The Uniiqa+ sensor is composed of two sensitive lines of 4096 pixels of 5µm square : One composed of Green pixels only, the second one composed alternatively of Red/Blue Pixels.

Each pixel on the same column uses its own Analog to Digital Column converter (ADC Column).

This structure allows several definitions :

- 4k pixels 5x5µm (Full Definition) :
- The 2 color lines are exposed with a delay of one line in order to match the same position between the green line and the red/blue line
- 2k Pixels 10x10µm (True Color) :
- The colored pixel is composed of 2x Green pixels, one red and one blue exposed in the same time.
- Then, 1k or 0,5k 10x10µm are achieved by applying an ROI on the centre of the sensor from the 2k 10x10µm

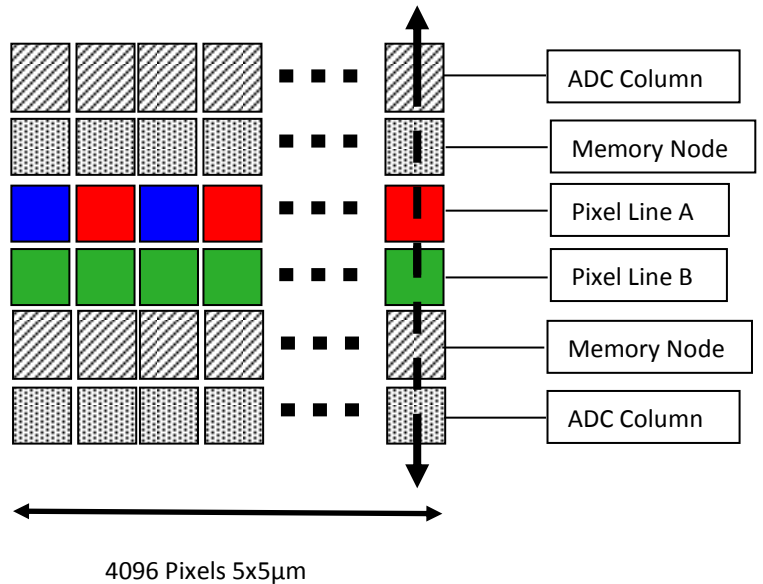

2.2.1 4k pixels 5x5µm (Full Definition)

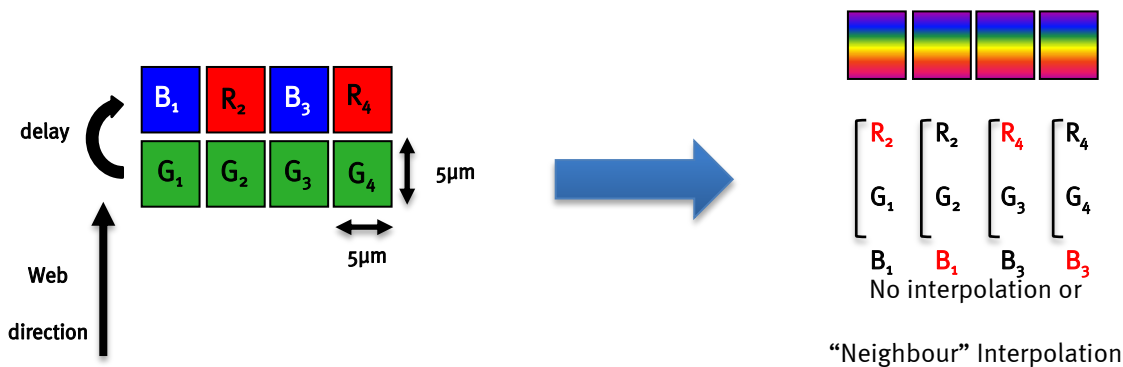

This color mode (5µm) requires the indication of "Forward/Reverse" to the camera in order to manage the delay between the two colored lines.

2.2.2 2k, 1k or 512 pixels 10x10µm (True Color)

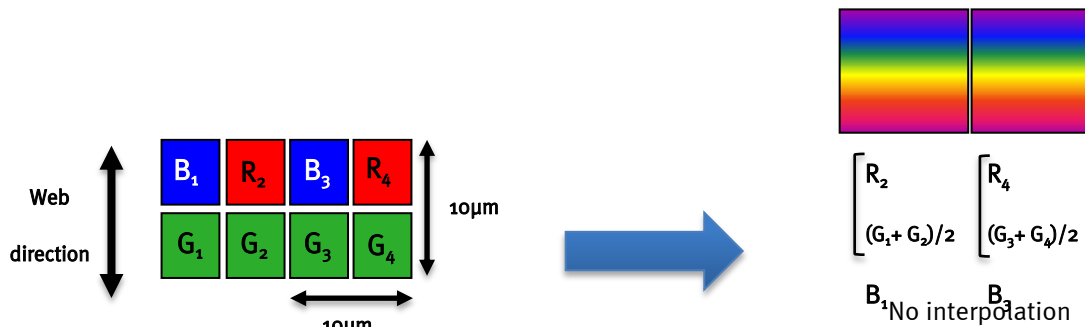

These color modes don't require any Reverse/Forward indication if no interpolation is used (or only the "column interpolation")

2.2.3 Column Interpolation

This interpolation is used to compensate the color error in the Red or the Blue in case of a vertical transition on the web : The Red of the blue value of each colored pixel is corrected if the variation between two neighbour green pixels is significant.

$B_1' = \alpha_B \times B_1$ and α_B is the blue correction, calculated with the variation $(G_1 - G_2)$

$R_2' = \alpha_R \times R_2$ and α_R is the red correction, calculated with the variation $(G_1 - G_2)$

- This interpolation is available for all pixel sizes : 5x5µm but also 10x10µm
- It can be disabled by the customer. By default, it is enabled.

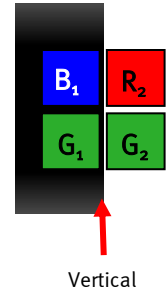

2.2.4 Line Interpolation

This interpolation is used to compensate the color error in the Red or the Blue in case of a horizontal transition on the web in the same “True Color” pixel : A line is memorized and the Red of the blue value of each colored pixel is corrected if the variation between two consecutive green values (previous to next line) is significant :

$B_1' = \alpha_B \times B_1$ and α_B is the blue correction, calculated with the variation $(G_1 - G'_1)$

$R_2' = \alpha_R \times R_2$ and α_R is the red correction, calculated with the variation $(G_2 - G'_2)$

- This interpolation is available only for pixel size 10x10µm (True Color)
- It can be enabled by the customer. By default, it is disabled
- This interpolation requires the Forward/Reverse indication sent to the camera for the memorized line.

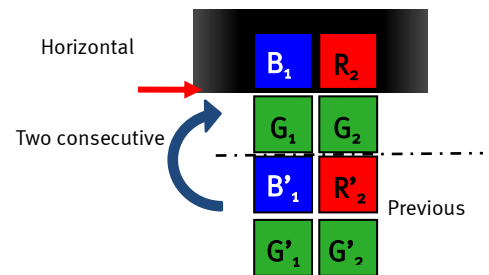

The Line Interpolation **has to be disabled** if the light is changing for each Line (typically for pulsed Light source with different spectrum) or for any reason the Green component of the light source changes significantly from one line to the next one.

2.2.5 Effects of the interpolations

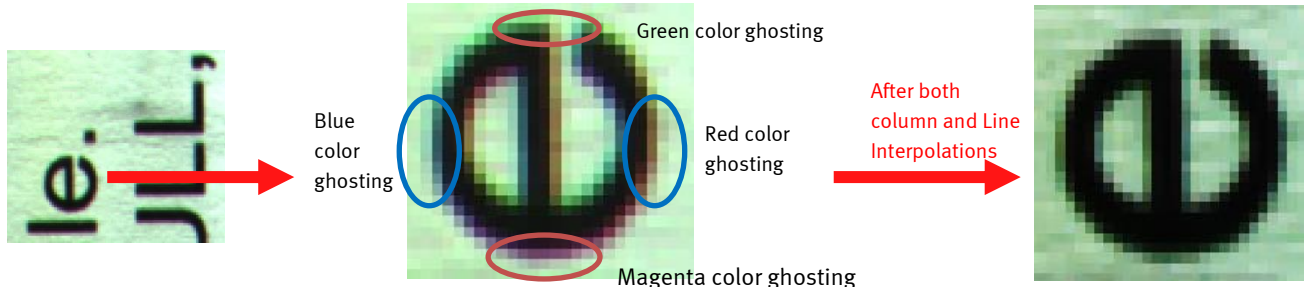

Horizontal transition effect reduced by the "Line Interpolation"



Vertical transition effect reduced by the "Column Interpolation"

2.3 Response & QE curves

2.3.1 Quantum Efficiency

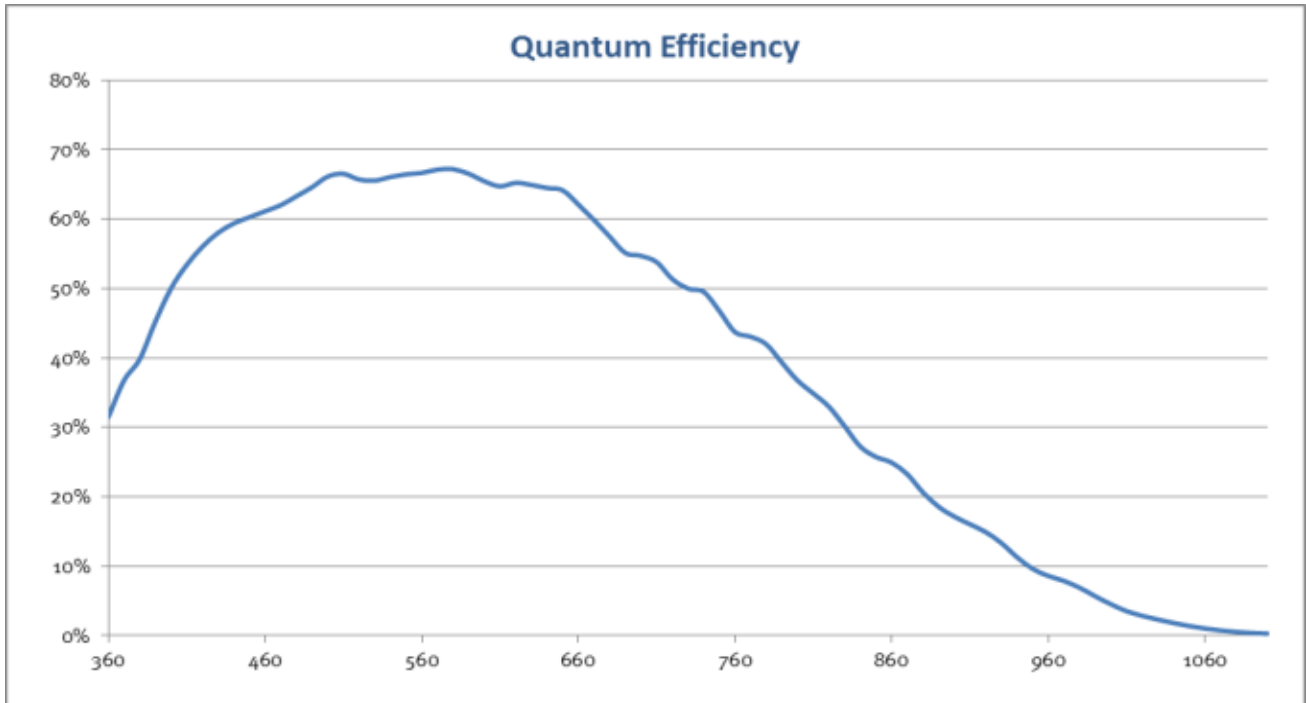

2.3.2 Spectral Response Curve

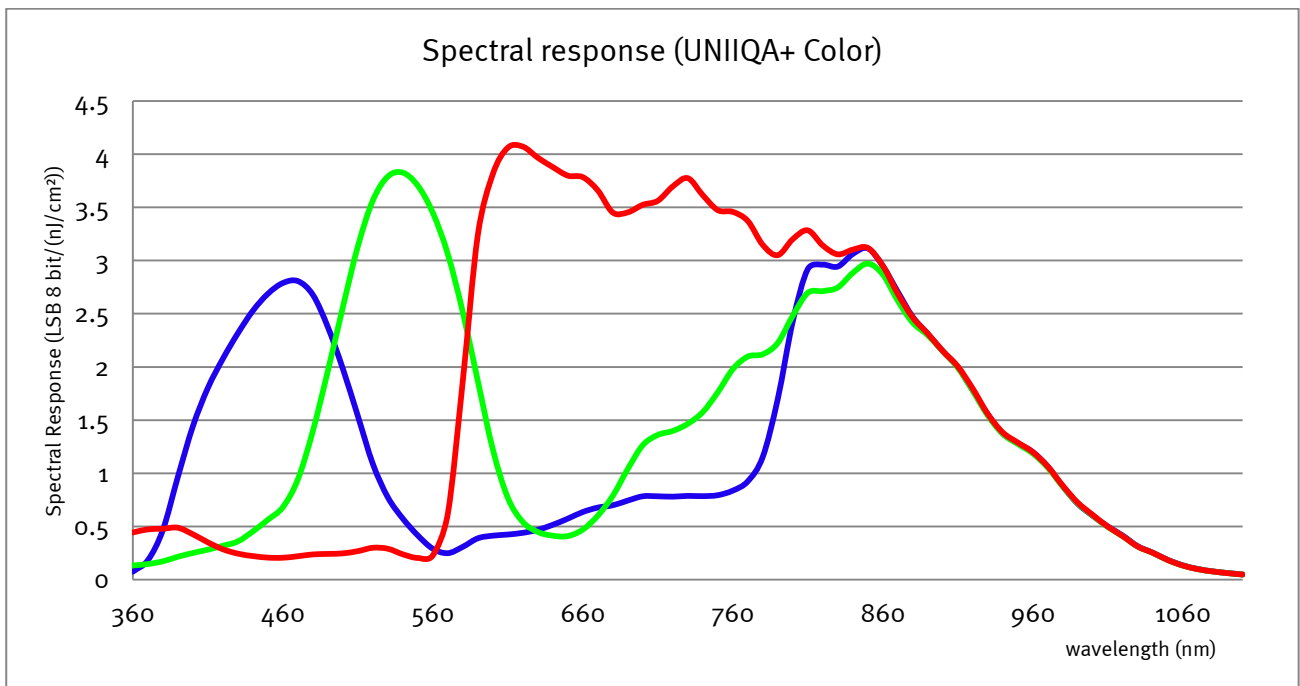

3 Camera Hardware and Interface

3.1 Mechanical Drawings

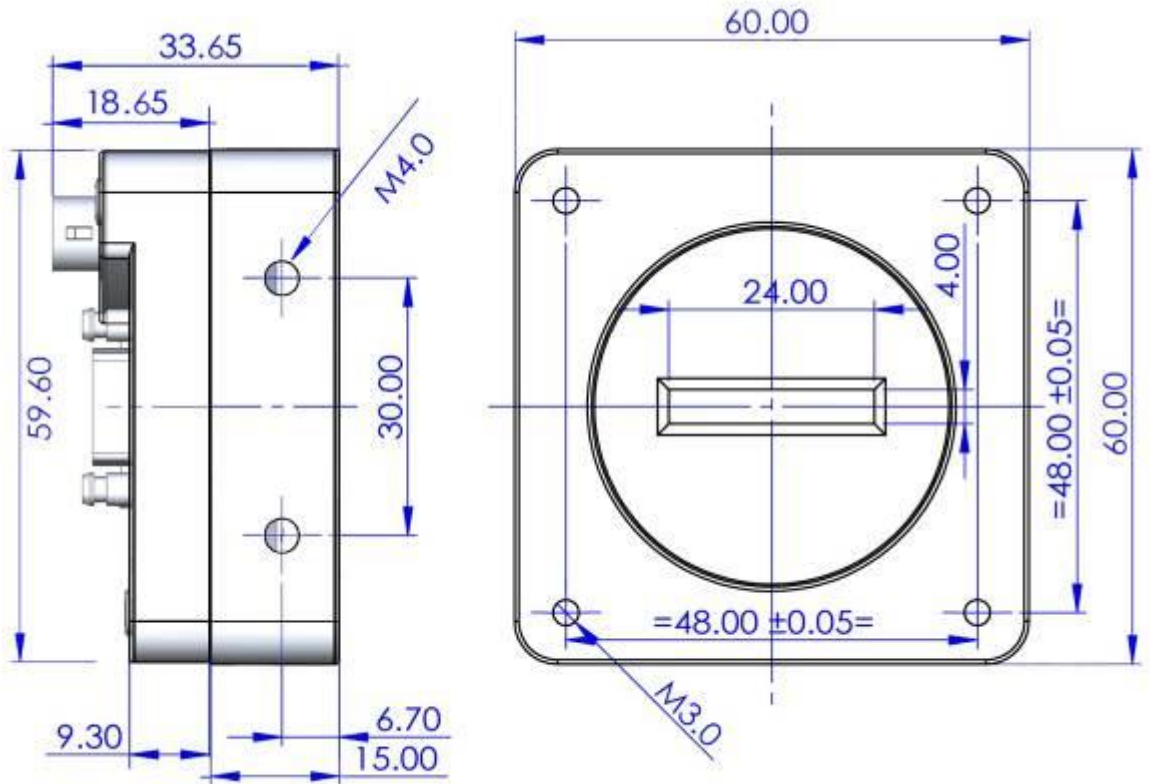

Essential Model

The Step file is available on the web : www.e2v.com/cameras

High Speed Model

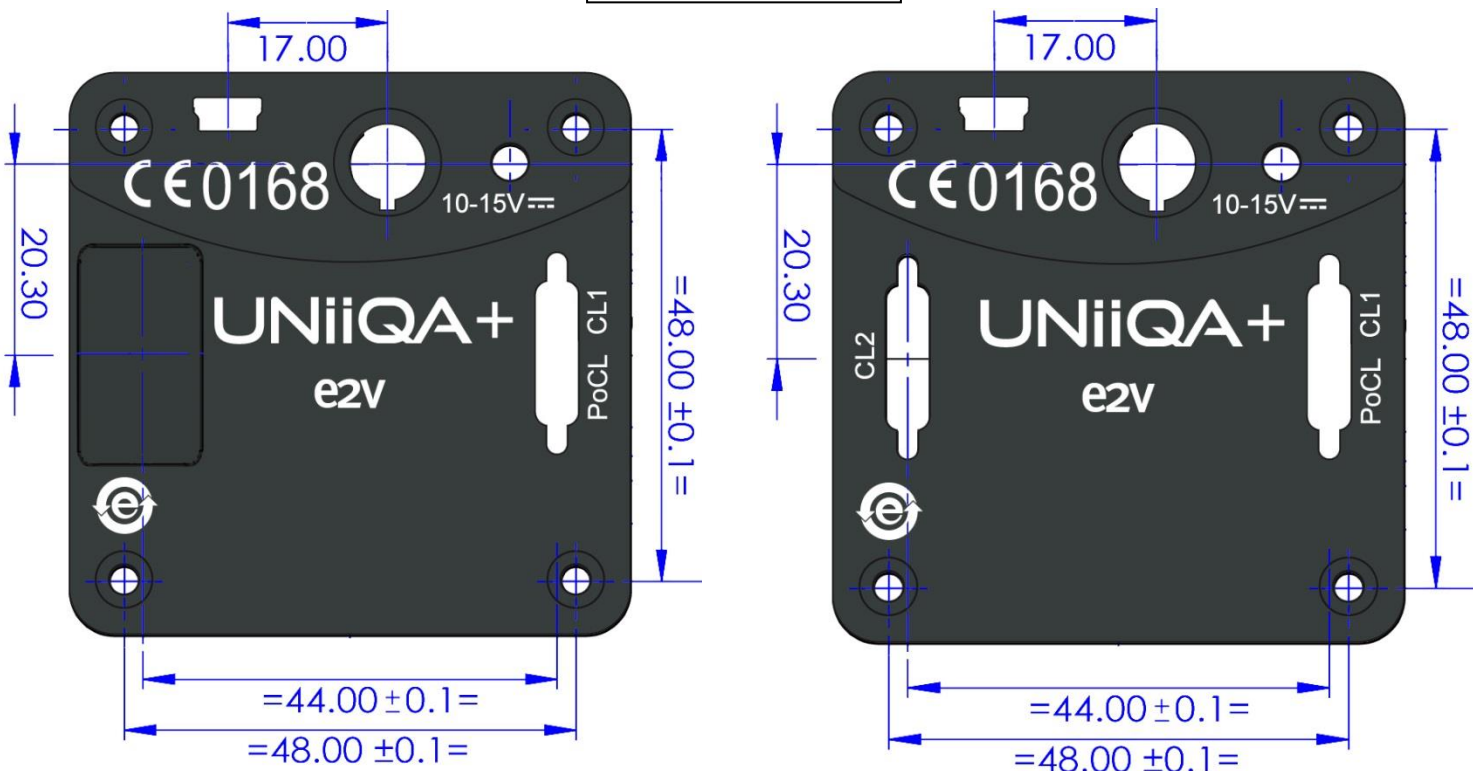

Sensor alignment	
Z = -10.3 mm	±100µm
X = 9.5 mm	±100 µm
Y = 62.5mm	±100 µm
Die flatness	50 µm
Rotation (X,Y plan)	±0.3°
Parallelism	50µm

3.2 Input/output Connectors and LED

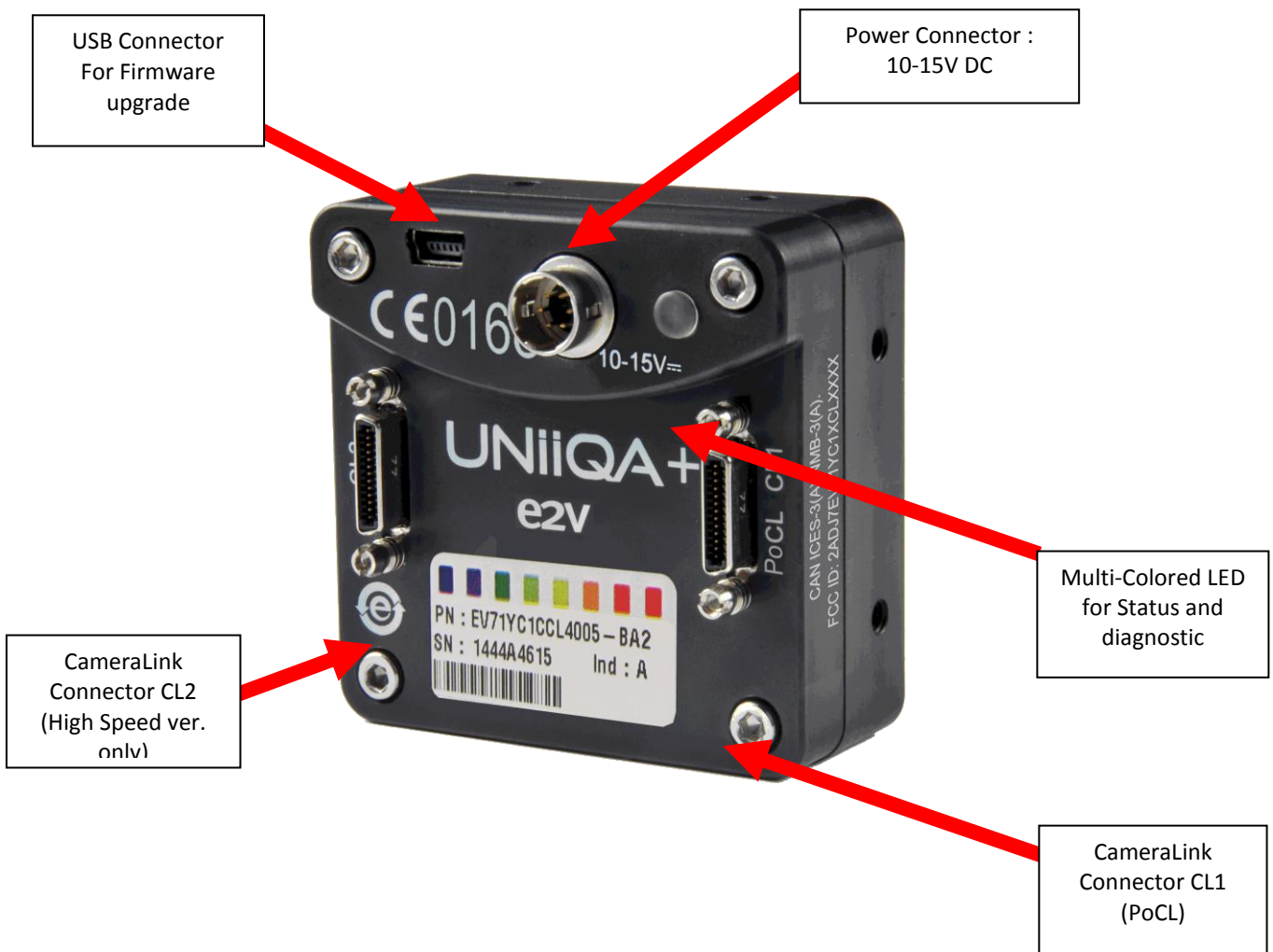

3.2.1 Power Connector

Camera connector type: Hirose HR10A-7R-6PB (male)

Cable connector type: Hirose HR10A-7P-6S (female)

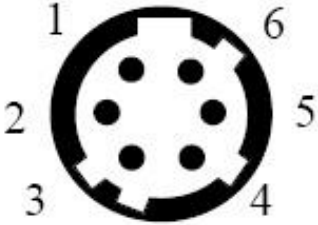
 <p>Camera side description</p>	Signal	Pin	Signal	Pin
	PWR	1	GND	4
	PWR	2	GND	5
	PWR	3	GND	6
Power supply from 10 to 15V Power 3,5W max with an typical inrush current peak of 0,32A during power up				

3.2.2 Consumption and Inrush Current

Typical current/Power during the grab (possible variation : +/- 5%)

Camera supply (Max Speed)	Supply 10V		Supply 12V		Supply 15V	
	I(mA)	P(W)	I(mA)	P(W)	I(mA)	P(W)
Essential	314	3.14W	263	3.15W	214	3.21W
High Speed	314	3.14W	263	3.15W	214	3.21W

Power Time : Max 3s (Green Light)

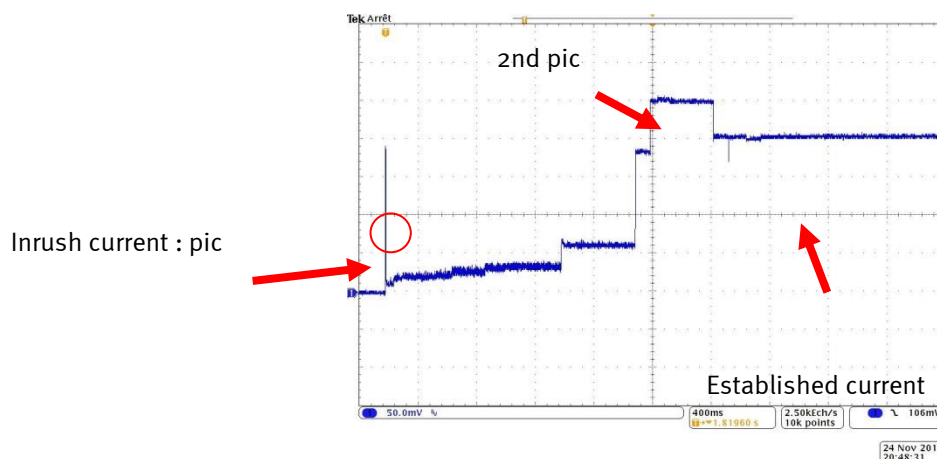

3.2.3 Status LED Behaviour

After less than 2 seconds of power establishment, the LED first lights up in ORANGE. Then after a Maximum of 3 seconds, the LED must turn in a following color :

Color and state	Meaning
Green and continuous	OK
Green and blinking slowly	Waiting for External Trigger (Trig1 and/or Trig2)
Red and continuous	Camera out of order : Internal firmware error
Orange and Continuous	Camera booting or upgrading

3.2.4 CameraLink Output Configuration

	Adjacent Channels	RGB Pixels per Channel			
Version "Essential" and "High Speed"		4k	2k	1k	0,5k
Base : 1 Channel 24 bits RGB	1 x 85MHz (60/42.5MHz)	1 x 4096	1 x 2048	1 x 1024	1 x 512
Version "High Speed" only					
Base : 2 Channels 24 bits RGB	2 x 85MHz (60/42.5MHz)	2 x 2048	2 x 1024	2 x 512	2 x 256

4 Standard Conformity

The UNIIQA+ cameras have been tested using the following equipment:

- A shielded power supply cable
- A Camera Link data transfer cable ref. 1MD26-3560-00C-500 (3M), 1SF26-L120-00C-500 (3M)
- A linear AC-DC power supply

e2v recommends using the same configuration to ensure the compliance with the following standards.

4.1 CE Conformity

The UNIIQA+ cameras comply with the requirements of the EMC (European) directive 2004/108/EC (EN 50081-2, EN 61000-6-2).

CE 0168

4.2 FCC Conformity

The UNIIQA+ cameras further comply with Part 15 of the FCC rules, which states that: Operation is subject to the following two conditions:

- This device may not cause harmful interference, and
- This device must accept any interference received, including interference that may cause undesired operation

This equipment has been tested and found to comply with the limits for Class A digital device, pursuant to part 15 of the FCC rules. These limits are designed to provide reasonable protection against harmful interference when the equipment is operated in a commercial environment. This equipment generates, uses and can radiate radio frequency energy and, if not installed and used in accordance with the instruction manual, may cause harmful interference to radio communications. Operation of this equipment in a residential area is likely to cause harmful interference

Warning: Changes or modifications to this unit not expressly approved by the party responsible for compliance could void the user's authority to operate this equipment.

4.3 RoHS / Chinese RoHS

RoHS per EU Directive 2011/65/EC and WEEE per EU Directive 2002/96/EC
China Electronic Industry Standard SJ/T11364-2006



4.4 GenICam / GenCP

GenICam/GenCP XML Description File, Superset of the GenICam™ Standard Features Naming Convention specification

V1.5, Camera Link Serial Communication : GenICam™ Generic Control Protocol (Gen CP V1.0)

GEN<i>CAM

5 Getting Started

5.1 Out of the box

The contents of the Camera box is the following :

- One Camera UNIIQA+



There is no CDROM delivered with the Camera : Both User Manual (this document) and CommCam control software have to be downloaded from the web site : This ensure you to have an up-to-date version.

Main Camera page : www.e2v.com/cameras

On the appropriate Camera Page (UNIIQA+ Monochrome) you'll find a download link first version of CommCam compliant is indicated in the last Chapter

CommCam download requires a login/password :

Login : **commcam**
Password : **chartreuse**



5.2 Setting up in the system

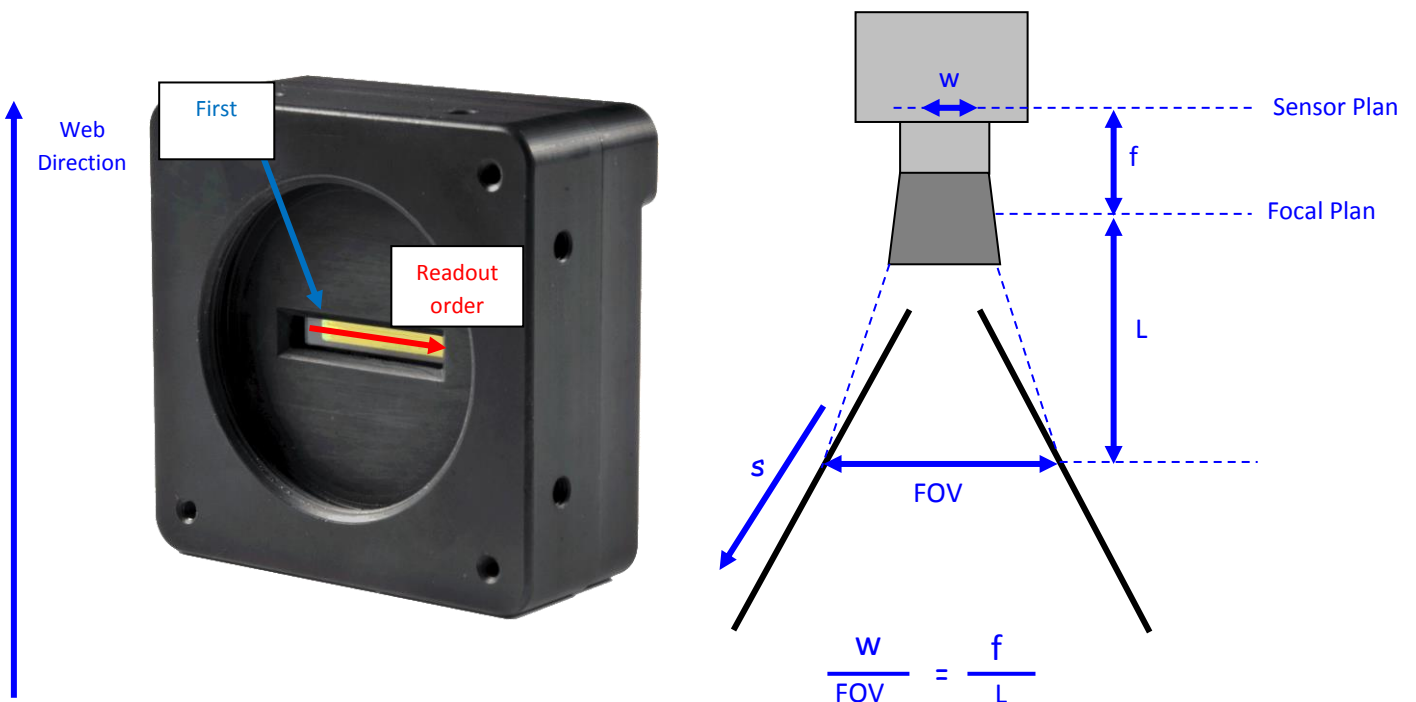

6 Camera Software Interface

6.1 Control and Interface

As all the e2v Cameras, the UNIIQA+ CL is delivered with the friendly interface control software COMMCAM.UCL (as “Ultimate Camera Link”) which is based on the GenICam standard

COMMCAM recognizes and detects automatically all the UCL Cameras connected on any transport layers (Camera Link or COM ports) of your system.

Once connected to the Camera you have an easy access to all its features. The visibility of these features can be associated to three types of users: Beginner, Expert or Guru. Then you can make life easy for simple users.

Minimum version of CommCam is **2.4.3** in order to recognize the UNIIQA+ Color Camera (all versions)

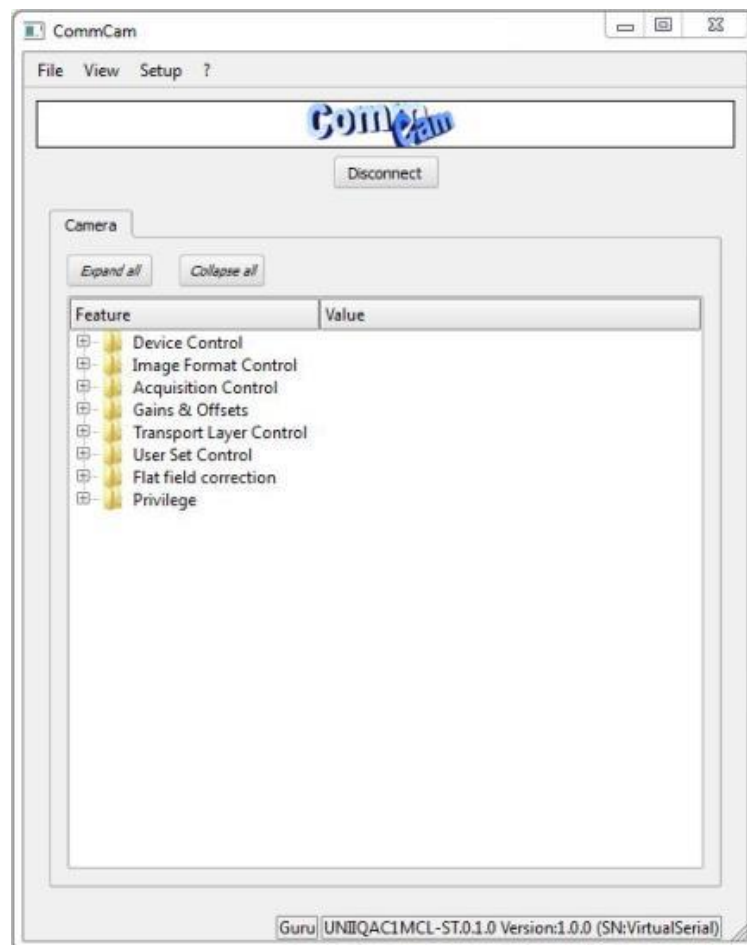

6.2 Serial Protocol and Command Format

The Camera Link interface provides two LVDS signal pairs for communication between the camera and the frame grabber. This is an asynchronous serial communication based on RS-232 protocol.

The serial line configuration is:

- Full duplex/without handshaking
- 9600 bauds (default), 8-bit data, no parity bit, 1 stop bit. The baud rate can be set up to 115200

6.2.1 Syntax

Internal camera configurations are activated by write or readout commands.

The command syntax for write operation is:

```
w <command_name> <command_parameters> <CR>
```

The command syntax for readout operation is:

```
r <command_name> <CR>
```

6.2.2 Command Processing

Each command received by the camera is processed:

- The setting is implemented (if valid)
- The camera returns “>”<return code><CR>

The camera return code has to be received before sending a new command.



The camera return code has to be received before sending a new command. Some commands are longer than the others : Waiting for the return code ensure a good treatment of all the commands without saturating the buffer of the camera.

6.2.3 GenCP Compliance

The camera is compliant with the GenCP standard. It is also still compliant with ASCII command format : Both types of commands are detailed in the next chapter.

GenCP requires a certain time for the command execution:

- Maximum Device Response Time : This register gives the max time for the execution of any command. Usually it's set at a value lower than 300ms
- If the execution time of the command is greater than 300ms, the camera sends a “pending acknowledge” command which gives the duration of this command : It can't be greater than 65536ms

6.2.4 Error code table

The error codes returned by the camera are compliant with the GenCP standard :

Status Code (Hex)	Name	Description
0x0000	GENCP_SUCCESS	Success
0x8001	GENCP_NOT_IMPLEMENTED	Command not implemented in the device.
0x8002	GENCP_INVALID_PARAMETER	At least one command parameter of CCD or SCD is invalid or out of range.
0x8003	GENCP_INVALID_ADDRESS	Attempt to access a not existing register address.
0x8004	GENCP_WRITE_PROTECT	Attempt to write to a read only register.
0x8005	GENCP_BAD_ALIGNMENT	Attempt to access registers with an address which is not aligned according to the underlying technology.
0x8006	GENCP_ACCESS_DENIED	Attempt to read a non-readable or write a non-writable register address.
0x8007	GENCP_BUSY	The command receiver is currently busy.
0x800B	GENCP_MSG_TIMEOUT	Timeout waiting for an acknowledge.
0x800E	GENCP_INVALID_HEADER	The header of the received command is invalid. This includes CCD and SCD fields but not the command payload.
0x800F	GENCP_WRONG_CONFIG	The current receiver configuration does not allow the execution of the sent command.
0x8FFF	GENCP_ERROR	Generic error.

7 Camera Commands

The Following chapter is about the camera commands. These commands are detailed in tables with both ASCII and GenCP forms. See below how to read the tables :

GenCP address	ASCII command	GenICam command	Size	R/W	Description
0x12100	tper	LinePeriod	4	RW	Line period from 1 (0.1us) to 65535 (6553,5us) step 1 (0.1us)

Register address for the GenCP Command
ASCII Command. "NA" when pure GenCP command
GenICam (SFNC) name
Register size (in Bytes)
RW : Read/Write
RO : Read Only
WO : Write Only
Command details

7.1 Device Information

These values allow to identify the Camera.

GenCP address	ASCII command	GenICam command	Size	R/W	Description
0x0000	NA	GenCPVersion	4	R	Complying GenCP specification version
0x0004	vdnm	ManufacturerName	64	R	String containing the self-describing name of the manufacturer
0x0044	mdnm	ModelName	64	R	String containing the self-describing name of the device model
0x00C4	dhvv	DeviceVersion	64	R	String containing the version of the device
0x0104	idnb	ManufacturerInfo	64	R	String containing additional manufacturer info
0x0144	deid	SerialNumber	64	R	String containing the serial number of the device
0x0184	cust	UserDefinedName	64	RW	String containing the user define name of the device
0x01C4	NA	DeviceCapability	8	R	Bit field describing the device's capabilities
0x1CC	NA	MaximunDevice ResponseTime	4	R	Maximum response time in milliseconds

- **Device User ID (*UserDefinedName*)** : Camera identifier set by the User in a 64Bytes String.
 - ⇒ Read function (ASCII): "**r cust**";
Returned by the camera : String of 64 bytes (including "/0")
 - ⇒ Write function (ASCII): "**w cust <idstr>**"

7.2 Device Privilege, Standby, Status and Reboot

GenCP address	ASCII command	GenICam command	Size	R/W	Description
0x17040	lock	PrivilegeLevel	4	RW	Read: <ul style="list-style-type: none"> ▪ 0 : Factory ▪ 1 : Advance User ▪ 2 : User Write : <ul style="list-style-type: none"> ▪ 1 : change mode from factory to AdvanceUser ▪ 2 : change mode to User ▪ Other: key to unlock the camera
0x17048	stat	Status	4	RO	Camera Status; bit set when : <ul style="list-style-type: none"> ▪ Bit0 :no trigger during more than 1s ▪ Bit1 : trigger too fast ▪ Bit2 : reserved ▪ Bit8 : overflow occurs during FFC calibration ▪ Bit9 : underflow occurs during FFC calibration ▪ Bit16 : hardware error detected
0x17050	boid	BoardID	32	R	Unique Board Identification. Written by the camera manufacturer or test bench
0x17070	bost	BoardStatus	16	R	Give the status of the board. Written by the camera manufacturer or the test bench
0x17080	boot	RebootCamera	4	WO	Reboot the camera with a command <ul style="list-style-type: none"> ▪ 1 restart the camera (like a power cycle) ▪ 2 restart only camera application (bypass upgrade application)

- **Privilege level Management ([PrivilegeLevel](#))** : Get the current Camera privilege level.
 - ⇒ Read function (ASCII): **"r lock"** : Get the current privilege
Returned by the camera : 0 to 2
 - ⇒ Write function (ASCII): **"w lock <val>"** : <val> is as follow
 - **2** : Lock the Camera in Integrator or "privilege User"
 - **<computed value>** : Unlock the Camera back in Integrator mode

There are 3 privilege levels for the camera :

- Factory (0) : Reserved for the Factory
- Integrator (1) : Reserved for system integrators
- User (2) : For all Users.

The Cameras are delivered in Integrator mode. They can be locked in User mode and a specific password is required to switch back the Camera in Integrator mode. This password can be generated with a specific tool available from the hotline (hotline-cam@e2v.com)

- **Camera status** : Get the Camera status register (32bits Integer)
 - ⇒ Read function (ASCII): “**r stat**”;
Returned by the camera : 32bits integer :
 - **Bit 0** : (*StatusWaitForTrigger*) : True if no trig received from more than 1sec
 - **Bit 1** : (*StatusTriggerTooFast*) : Missing triggers. Trig signal too fast
 - Bit 2, 3, 4, 5, 6, 7 : Reserved
 - **Bit 8** : (*StatusWarningOverflow*) : True is an overflow occurs during FFC or Tap balance processing.
 - **Bit 9** : (*StatusWarningUnderflow*) : True is an underflow occurs during FFC or Tap balance processing
 - Bits, 10, 11, 12, 13, 14, 15 : Reserved
 - **Bit 16** : (*StatusErrorHardware*) : True if hardware error detected
 - Bits, 17 to 31 : Reserved

7.3 Communication and Firmware version

GenCP address	ASCII command	GenICam command	Size	R/W	Description
0x10000	NA	SupportedBaudrate	4	R	Supported baudrate: 0x3B = mask of all the following : 0x01 : BAUDERATE_9600 0x02 : BAUDERATE_19200 0x08 : BAUDERATE_57600 0x10 : BAUDERATE_115200 0x20 : BAUDERATE_230400
0x10004	baud	<i>CurrentBaudrate</i>	4	RW	Current baudrate: 0x01 : BAUDERATE_9600 0x02 : BAUDERATE_19200 0x08 : BAUDERATE_57600 0x10 : BAUDERATE_115200 0x20 : BAUDERATE_230400
0x10008	dfwv	DeviceFirmwareVersion	16	RO	Version of the current package

- **Device Serial Port Baud Rate** (*CurrentBaudRate*): Set the Camera Baud Rate
 - ⇒ Read function (ASCII): “**r baud**”;
Returned by the camera : Value of the Baud Rate
 - ⇒ Write function (ASCII): “**w baud**” <index> with the index as follows :
 - 1 (0x01) : 9600 Bauds (default value at power up)
 - 2 (0x02): 19200 Bauds
 - 8 (0x08): 57600 Bauds
 - 18 (0x10): 115200 Bauds
 - 32(0x20) : 23040 Bauds

7.4 Image Format

GenCP address	ASCII command	GenICam command	Size	R/W	Description
0x12000	sns	SensorWidth	4	R	Pixels number (can be set for versatile model)
-	-	SensorHeight	4	R	1
-	-	WidthMax	4	R	Pixels number (can be set for versatile model)
-	-	HeightMax	4	R	1
-	-	Height	4	R	1
-	-	Width	4	R	Pixels number (can be set for versatile model)
0x12004	smod	SensorMode	4	RW	Depending the model of the camera 0 : 4096 Pixels, 5x5µm 1 : 2048 pixels 10x10µm 2 : 1024 pixels 10x10µm (<i>Versatile only</i>) 3 : 512 pixels 10x10µm (<i>Versatile only</i>)
0x12008	revr	ReverseReading	4	RW	0 : disable 1 : enable
0x1200C	mode	OutputMode	4	RW	0 : Base 1 Output 24-bit 1 : Medium 2x output 24-bit (<i>High Speed only</i>)
0x12010	clfq	OutputFrequency	4	RW	Configure the CameraLink Interface frequency 0 : 85MHz 1 : 60MHz 2 : 42.5 MHz
0x12014	srce	TestImageSelector	4	RW	0 : "Off" (Sensor image) 1 : "GreyHorizontalRamp" 2 : "whitePattern" 3 : "GrayPattern" 4 : "BlackPattern" 5 : "GreyVerticalRampMoving"
0x12018	temp	Temperature	4	RO	Read temperature value Format : Integer in degree Celsius
0x1201c	scdi	ScanDirection	4	RW	Set/Get Scan Direction (forward or reverse) 0: Forward 1: Reverse 2: Externally control by CC3 signal o CC3=0: Forward o CC3=1: Reverse

- **Sensor Mode ([SensorMode](#))** : Defines the number of pixels and their size. Only available for versatile models.
This command is available in the CommCam "Image Format Control" section :

- ⇒ Read function (ASCII): "**r smod**";
Returned by the camera : Integer from 0 to 3
- ⇒ Write function (ASCII): "**w smod**" <value> :
 - "0" : 4096 pixels, 5x5µm
 - "1" : 2048 pixels, 10x10µm
 - "2" : 1024 pixels, 10x10µm
 - "3" : 512 pixels, 10x10µm

- **Reverse Reading (X) (*ReverseReading*)** : Allows to output the line in the Reverse-X direction.
This value is available in the CommCam “Image Format Control” section :
 - ⇒ Read function : “**r revr**”;
Return by the Camera : 0 or 1 (enabled/disabled)
 - ⇒ Write function : “**w revr <value>**”;
 - “0” : Disabled.
 - “1” : Enables the reverse reading out

- **Output mode (*OutputMode*)** : Set the CameraLink Output mode.
This command is available in the CommCam “Image Format Control” section :
 - ⇒ Read function (ASCII): “**r mode**”;
Returned by the camera : Output mode from 0 to 7 (see table below).
 - ⇒ Write function (ASCII): “**w mode**” <value> :
detailed in the table below :

Modes	Connector CL1	Connector CL2	Mode value
Base 1 Channel 24 Bits	3 x 8 bits (RGB)	-	0
Medium 2 Channels 24bits (High Speed Version Only)	3 x 8 bits (RGB)	3 x 8 bits (RGB)	1

Structure of the Camera Link Channels for interfacing



- **Base Mode** : 1 RGB Channel, outputted from Left to Right

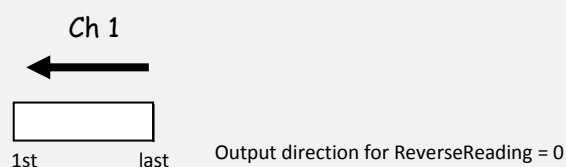

- **Medium Mode** : 2 RGB Channels separate, outputted from Left to Right



The following table details the possible combinations :

Modes	4096	2048	1024	512
Base 1 Channel 24 Bits	1 x 4096	1 x 2048	1 x 1024	1 x 512
Medium 2 Channels 24 Bits	2 x 2048	2 x 1024	2 x 512	2 x 256

The table of the [appendix 10 chapter 10.2](#) gives the max speed achievable for each of these combinations in addition with the combination of the Output Data Frequency.

- **Output Frequency (*OutputFrequency*)** : Set the CameraLink Data Output Frequency. This value is available in the CommCam “Image Format Control” section :
 - ⇒ Read function (ASCII): “**r clfq**”;
Return by the Camera : Frequency from 0 to 2
 - ⇒ Write Function (ASCII): “**w clfq <value>**”
 - “0” : 85MHz
 - “1” : 60MHz
 - “2” : 42.5MHz

- **Test Image Selector (*TestImageSelector*)** : Defines if the data comes from the Sensor or the FPGA (test Pattern). This command is available in the CommCam “Image Format” section :
 - ⇒ Read function (ASCII): “**r srce**”;
Returned by the camera : “0” if Source from the Sensor and “1 to 5” if test pattern active
 - ⇒ Write function (ASCII): “**w srce**” <value> :
 - “0” : To switch to CCD sensor image
 - “1” : Grey Horizontal Ramp (Fixed) : [See AppendixA](#)
 - “2” : White Pattern (Uniform white image : 255 in 8Bits or 4095 in 12bits)
 - “3” : Grey Pattern (Uniform middle Grey : 128 in 8bits or 2048 in 12 bits)
 - “4” : Black Pattern (Uniform black : 0 in both 8 and 12 bits)
 - “5” : Grey vertical Ramp (moving)

The test pattern is generated in the FPGA : It’s used to point out any interface problem with the Frame Grabber.
When any of the Test pattern is enabled, the whole processing chain of the FPGA is disabled.

- **Scan Direction (*ScanDirection*)** : Set the scan direction for the sensor. This value is available in the CommCam “Image Format Control” section :
 - ⇒ Read function : “**r scdi**”;
Return by the Camera : 0, 1 or 2 (Forward/reverse/external)
 - ⇒ Write function : “**w scdi <value>**”;
 - “0” : Forward.
 - “1” : Reverse
 - “2” : Externally controlled (by CC3 of the CameraLink Sync signals)

Forward/reverse information has to be set correctly For the re-ordering of the colors.

The Forward direction is defined as detailed beside :

Note : The delay for the Camera to take in account a change in the ScanDirection value is minimum **50ms**.

This information can be set dynamically by using the **CC3 Trig signal** of the CameraLink connector (change the direction “on the fly”).

In these case, the Trigger level signification is :

- “0” : Forward.
- “1” : Reverse

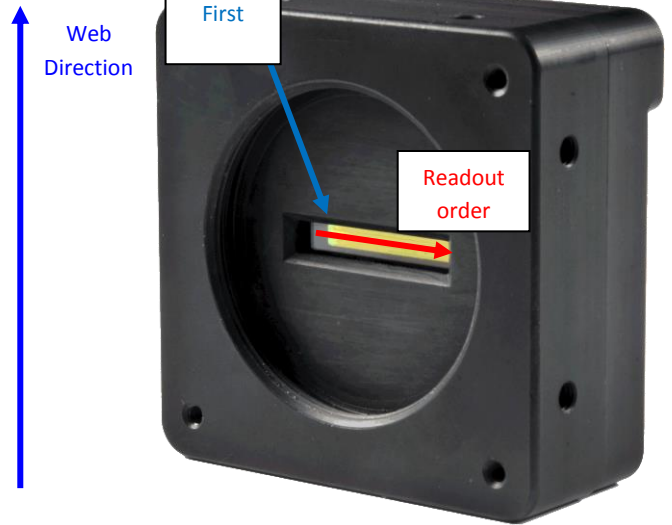

The Forward/Reverse indication is required in the following cases :

- The definition is 4k (Full definition) with a pixel of 5x5 μ m.
- The definition is 2k, 1k or 512 Pixel (True Color) with a pixel of 10x10 μ m **and** the Line Interpolation is enabled

7.5 Acquisition Control

GenCP address	ASCII command	GenICam command	Size	R/W	Description
0x12100	tper	LinePeriod	4	RW	Line period from 1 (0.1us) to 65535 (6553.5us) step 1 (0.1us)
0x12104	tpmi	LinePeriodMin	4	R	Minimum line period
-	-	AcquisitionLineRate	4	R	= 1 / Line Period in Hz
0x12108	tint	ExposureTime	4	RW	Exposure time from 15 (1.5us) to 65535 (6553.5us) step 1 (0.1us)
0x1210C	sync	TriggerPreset	4	RW	0 : Set trigger preset mode to Free run timed mode, with exposure time and line period programmable in the camera 1 : Set trigger preset mode to Triggered mode with Exposure Time Internally Controlled 2 : Set trigger preset mode to Triggered mode with maximum exposure time 3 : Set trigger preset mode to Triggered mode with exposure time controlled by one signal 4 : Set trigger preset mode to Triggered mode with exposure time controlled by two signals 5 : Set trigger preset mode to Free run mode, with max exposure time and programmable line period in the camera

- **Synchronisation Mode ([TriggerPreset](#))** : Timed or Triggered, it defines how the grabbing is synchronized. This command is available in the CommCam “Acquisition Control” section :
 - ⇒ Read function (ASCII): “**r sync**”;
 - Returned by the camera :
 - “0” : Internal Line Trigger with Exposure time Internally Controlled (Free Run).
 - “1” : External Trigger with Exposure Time Internally Controlled.
 - “2” : External Trigger with maximum Exposure time
 - “3” : One External with Exposure Time Externally Controlled. The same Trigger signal defines the line period and its low level defines the exposure time.
 - “4” : Two External Triggers with Exposure Time Externally Controlled : CC2 defines the start of the exposure (and also the start Line) and CC1 defines the Stop of the exposure.
 - “5” : Internal Line Trigger with maximum Exposure Time
 - ⇒ Write function (ASCII): “**w sync**” <value>



The Timing diagrams associated to each Synchronization mode and the Timing values associated are detailed in the [APPENDIX B](#) of this document.

- **Exposure time** (*ExposureTime*): Defines the exposure time when set in the Camera. This command is available in the CommCam “Acquisition Control” section :

- ⇒ Read function (ASCII): “**r tint**”;
Returned by the camera : Integer from 15 to 65535 (=1,5µs to 6553,5µs by step of 0,1µs)
- ⇒ Write function (ASCII): “**w tint**” <value> ;

This value of exposure time is taken in account only when the synchronisation mode is “free run” (0) or “Ext Trig with Exposure time set” (1). Otherwise it’s ignored.



Due to the limitation of the timing pixel inside the sensor, the Exposure time has to be set by taking in account the limitation detailed in the [APPENDIX B](#) of this document.

The **Minimum exposure time** which can be set is **1.5µs**

- **Line Period** (*LinePeriod*) : Defines the Line Period of the Camera in Timed mode. This command is available in the CommCam “Acquisition Control” section :

- ⇒ Read function (ASCII): “**r tper**”;
Returned by the camera : Integer from 1 to 65536 (=0.1µs to 6553.6µs by step o 100ns)
- ⇒ Write function (ASCII): “**w tper**” <value> ;

The line period is active only in modes Sync 0 and Sync 5. It’s also disabled if in Free Run (Sync 0), the Integration time is set higher than the Line Period.



The Tables of the minimum Line Period (Max Line Rate) versus the Data rate and the output mode chosen are given in [Appendix C \(Chap. 10.2\)](#) of this document.

7.6 Gains and Offsets

GenCP address	ASCII command	GenICam command	Size	R/W	Description
0x12200	pamp	GainAbs GainSelector = AnalogAll	4	RW	Pre-amplifier gain to: 0 : x1 1 : x2 2 : x4
0x12204	gain	GainAbs GainSelector = GainAll	4	RW	Digital gain from 0dB (0) to +8dB (6193) step 0.002dB
0x12208	gdig	GainAbs GainSelector = DigitalAll	4	RW	Contrast expansion (digital gain) from 0dB (0) to +14dB (255) step 0.135dB (1)
0x1220C	offs	BlackLevelRaw BlackLevelSelector =All	4	RW	Common black level from -4096 to 4095 step 1

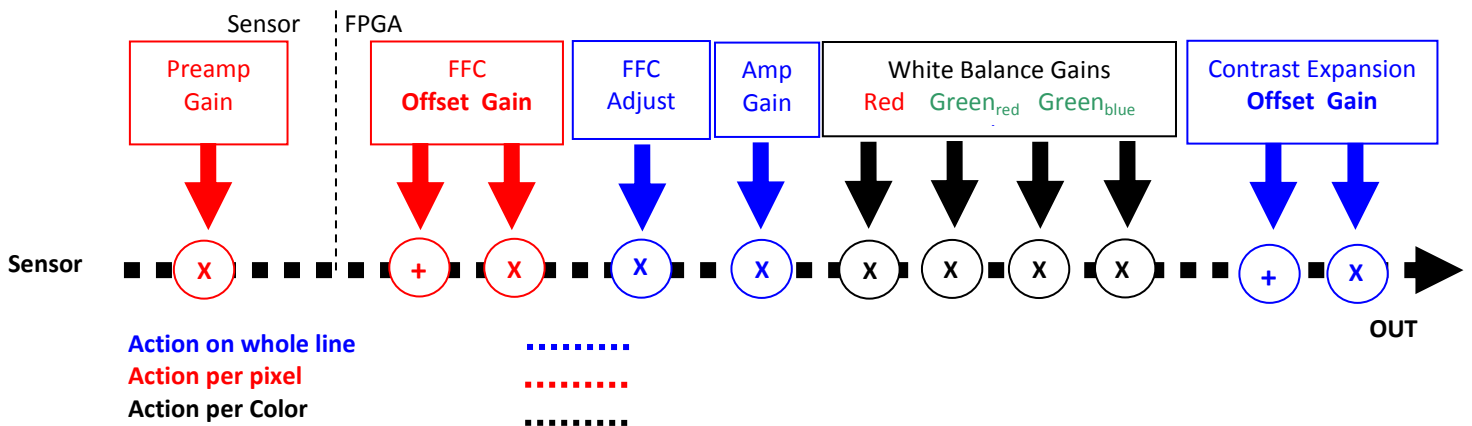

Analog Gain in the ADC



The only analog Gain available in the ELIIXA+ is located at the sensor level, in the ADC converter. This "Preamp Gain" is in fact a variation of the ramp of the comparator of the ADC. Then 3 Values are available : x1, x2 and x4. A gain x1 in a 12 bits conversion is equivalent to x4 in 10 bits.

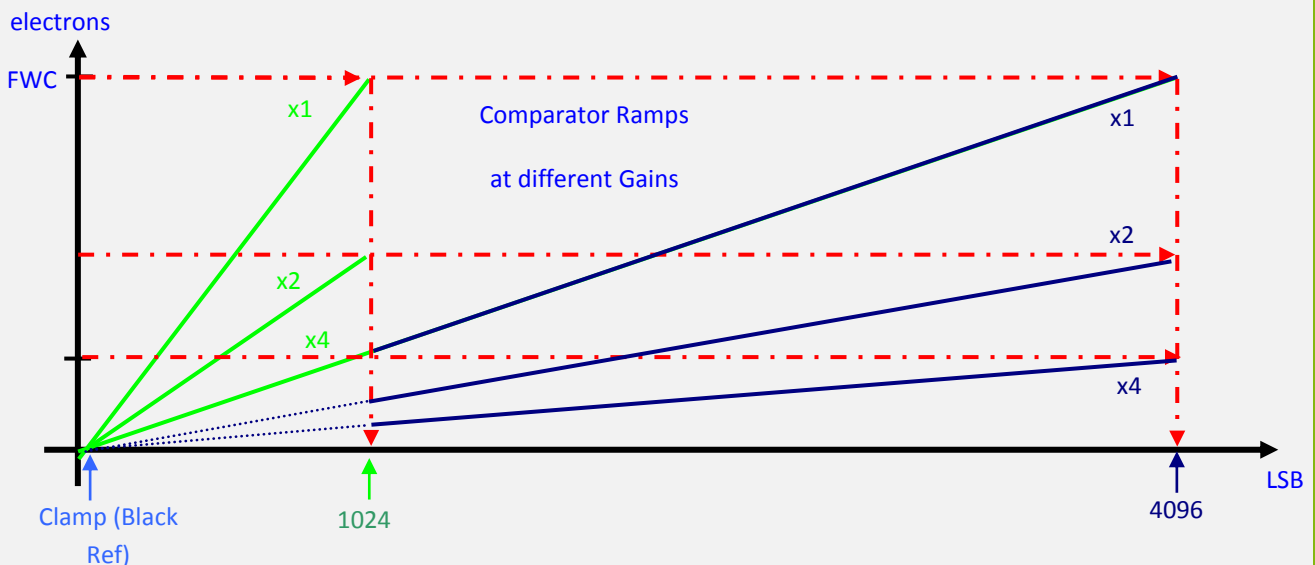

- **Preamp Gain** : (*GainAbs* with *GainSelector= AnalogAll*)
Set the Pre-amplification Gain. This command is available in the CommCam “Gain & Offset” section.
 - ⇒ Read function (ASCII): “**r pamp**”;
Returned by the camera : Integer corresponding to one of the 3 different step values :
 - 0 : x1 (0dB)
 - 1 : x2 (6dB)
 - 2 : x4 (12dB)
 - ⇒ Write function (ASCII): “**w pamp**” <int> ;

- **Gain**: (*GainAbs* with *GainSelector= GainAll*)
Set the Amplification Gain. This command is available in the CommCam “Gain & Offset” section :
 - ⇒ Read function (ASCII): “**r gain**”;
Returned by the camera : Value from 0 to 6193 corresponding to a Gain range of 0dB to +8dB calculated as following : $\text{Gain(dB)} = 20 \cdot \log(1 + \text{Gain}/4096)$.
 - ⇒ Write function (ASCII): “**w gain**” <int> ;

- **Digital Gain** (*GainAbs* with *GainSelector=DigitalAll*) : Set the global Digital Gain. This command is available in the CommCam “Gain & Offset” section :
 - ⇒ Read function (ASCII): “**r gdig**”;
Returned by the camera : Integer value from 0 to 255. The corresponding Gain is calculated as $20 \log(1 + \text{val}/64)$ in dB
 - ⇒ Write function (ASCII): “**w gdig**” <int> ;

- **Digital Offset** (*BlackLevelRaw* with *BlackLevelSelector=All*) : Set the global Digital Offset. This command is available in the CommCam “Gain & Offset” section :
 - ⇒ Read function (ASCII): “**r offs**”;
Returned by the camera : Value from -4096 to +4095 in LSB
 - ⇒ Write function (ASCII): “**w offs**” <int> ;

7.7 Color Management

GenCP address	ASCII command	GenICam command	Size	R/W	Description
0x12214	gwbr	GainAbs GainSelector = DigitalRed	4	RW	Gain for red color from 0 to 1548 (8dB) Use for white balance
0x12218	gwbb	GainAbs GainSelector = DigitalBlue	4	RW	Gain for Blue color from 0 to 1548 (8dB) Use for white balance
0x1221C	gwbg	GainAbs GainSelector = DigitalGreen(red)	4	RW	Gain for Green(Red) color from 0 to 1548 (8dB) Use for white balance
0x12220	gwbj	GainAbs GainSelector = DigitalGreenn(Blue)	4	RW	Gain for Green(Blue) color from 0 to 1548 (8dB) Use for white balance
0x12224	awbc	AutoWhiteBalanceStart	4	RW	Management of the White Balance Process Read: 0 : No Auto White balance in progress 1: Auto White Balance in progress Write: 0 : Stop Auto white balance 1: Start Auto white balance
0x12228	gwbe	WhiteBalanceEnable	4	RW	Enables the use of the White Balance Gains 0: Enable 1: Disable
0x1222c	ccit	ColumnInterpolation	4	RW	Enables the Column Interpolation 0: Enable 1: Disable
0x12230	clit	LineInterpolation	4	RW	Enables the Line Interpolation 0: Enable 1: Disable

As described in the [Chapter §2.2](#), the structure of the sensor differentiates Green pixels facing Blue or Red pixels. Then the white balance is associated with 4 color Gains :

- Red Gain
- Green_{Red} Gain
- Green_{Blue} Gain
- Blue Gain

The Color Selection or enabling (Image Format Chapter) can affect the way you're performing the white balance : For example, if you disable the Blue and the Red color, the "White Balance" will be performed only between the two Green Gains.

The dissociation of Green (blue) and Green (Red) is justified by the possible difference of response of the two types of Green because of their respective neighbor color influence and then the necessity to tune them separately.

As usual, for a perfect White balance, provide to the Camera a non-saturating white (gray) target in the center of the sensor.

The White balance has to be performed after the Flat Field Correction as each color is performing its own FFC with its own reference.

In any case, the best tuning of the Camera Gains is performed from the left to the right of the Gain Chain described above : Preamp Gain first and quarter Gains last (if required).

The Following Gains are enabled by the White balance Enable switch :

- **Digital Red Gain** (*Gain* with *GainSelector=DigitalRed*) : Set the Red Gain for the white balance. This command is available in the CommCam “Color Management” section :
 - ⇒ Read function : “**r gwbr**”;
 - Returned by the camera : Integer value from 0 to 1548. The corresponding Gain is calculated as $20.\log(1 + \text{<val>/1024})$ in dB
 - ⇒ Write function : “**w gwbr**” <val> ;
- **Digital Blue Gain** (*Gain* with *GainSelector=DigitalBlue*) : Set the Blue Gain for the white balance. This command is available in the CommCam “Color Management” section :
 - ⇒ Read function : “**r gwbb**”;
 - Returned by the camera : Integer value from 0 to 1548. The corresponding Gain is calculated as $20.\log(1 + \text{<val>/1024})$ in dB
 - ⇒ Write function : “**w gwbb**” <val> ;
- **Digital Green_{Red} Gain** (*Gain* with *GainSelector=DigitalGreenR*) : Set the Green_{Red} Gain for the white balance. This command is available in the CommCam “Color Management” section :
 - ⇒ Read function : “**r gwbg**”;
 - Returned by the camera : Integer value from 0 to 1548. The corresponding Gain is calculated as $20.\log(1 + \text{<val>/1024})$ in dB
 - ⇒ Write function : “**w gwbg**” <val> ;
- **Digital Green_{Blue} Gain** (*Gain* with *GainSelector=DigitalGreenB*) : Set the Green_{Blue} Gain for the white balance. This command is available in the CommCam “Color Management” section :
 - ⇒ Read function : “**r gwbj**”;
 - Returned by the camera : Integer value from 0 to 1548. The corresponding Gain is calculated as $20.\log(1 + \text{<val>/1024})$ in dB
 - ⇒ Write function : “**w gwbj**” <val> ;
- **White Balance Enable Switch** (*WhiteBalanceEnable*) : Enables the White Balance Gains. This command is available in the CommCam “Color Management” section :
 - ⇒ Read function : “**r gwbe**”;
 - Returns the White Balance Gain Enable Status.
 - ⇒ Write function : “**w gwbe** <val>” with <val> : 0 or 1
 - 0 : Disables the White Balance Gains
 - 1 : Enables the White Balance Gains
- **White Balance Calibration Control** (*AutoWhiteBalanceStart*) : Launch or abort of the White Balance process for the RGB Gains calculation. This command is available in the CommCam “Color Management” section :
 - ⇒ No Read Function
 - ⇒ Write function :
 - “**w awbc 1**” : Launch the White Balance Calibration Process.
 - “**w awbc 0**” : Abort the White Balance Calibration Process.

- **Column Interpolation Enable Switch (ColumnInterpolation)** : Enables the Column Interpolation. This command is available in the CommCam “Color Management” section :
 - ⇒ Read function : “r **ccit**”;
Returns the Colum Interpolation Enable Status.
 - ⇒ Write function : “w **ccit** <val>” with <val> : 0 or 1
 - 0 : Disables the Colum Interpolation
 - 1 : Enables the Colum Interpolation
- **Line Interpolation Enable Switch (ColumnInterpolation)** : Enables the Line Interpolation. This command is available in the CommCam “Color Management” section :
 - ⇒ Read function : “r **clit**”;
Returns the Line Interpolation Enable Status.
 - ⇒ Write function : “w **clit** <val>” with <val> : 0 or 1
 - 0 : Disables the Line Interpolation
 - 1 : Enables the Line Interpolation



Column and Line Interpolation.

Please, refer to [chapter §2.2](#) for a detailed explanation of these two interpolations available for the User.

7.8 Flat Field Correction

GenCP address	ASCII command	GenICam command	Size	R/W	Description
0x12300	ffcp	FFCEnable	4	RW	0 : Disable : Raw sensor 1 : Enable
0x12304	rsto	FPNReset	4	WO	Reset FPN coefficients
0x12308	rstg	PRNUReset	4	WO	Reset PRNU coefficients
0x1230C	calo	FPNCalibrationCtrl	4	RW	FPN calibration control Read : 0 : no calibration in progress 1 : Calibration in progress Write : 0 : stop calibration 1 : Start Calibration
0x12310	calg	PRNUCalibrationCtrl	4	RW	FPN calibration control Read : 0 : no calibration in progress 1 : Calibration in progress Write : 0 : stop calibration 1 : Start Calibration
0x12314	lffw	LowFilterFFCWidth	4	RW	Width of the low filter for PRNU calculation : From 0 to 63. 0 is for a disabled filter.
-	ffca	FFCAddress	4	RO	Set the FFC address to access auto incremental (after each FFC access) Address Offset : 0 to 2047 : red 2048 to 4095 : blue 4096 to 6143 : green(red) 6144 to 8191 : green (blue)
0x12400	ffco	FPNCoefficientsAccess	8192 /2	RW	Access to FPN coeff. Format S9.1: -256 (512) to -1 (1023), 0 (0) to 255.5 (511) step 0.5
0x13400	ffcg	PRNUCoefficientsAccess	8192 /2	RW	Access to PRNU coeff. Format S1.13: 1 (0) to 3.999 (4095) step 1/1024

- **FFC Activation ([FFCEnable](#))** : Enable/disable the Flat Field Correction. This command is available in the CommCam “Flat Field Correction” section :
 - ⇒ Read function (ASCII): “**r ffc**” : Returns the FFC Status (0 if disabled, 1 if enabled)
 - ⇒ Write function (ASCII):
 - “**w ffc 1**” (ASCII): Enable the FFC.
 - “**w ffc 0**” (ASCII) : Disabled the FFC

- **Low Filter FFC With (*FFCEnable*)** : Set and Enable/disable the Flat Field Correction Low Band Filter. This command is available in the CommCam “Flat Field Correction” section :
 - ⇒ Read function (ASCII): “**r lffw**” : Returns the FFC Status (0 if disabled, X>0 enabled and set at X)
 - ⇒ Write function (ASCII):
 - “**w lffw <val>**” (ASCII): set the FFC Low band Filter at <val>. If <val> is 0, then the Low Band filter is disabled



FFC Low Band Filter.

The FFC Low Band Filter allows an easier make in use of the FFC (PRNU Part) : You can use a non-moving paper and you can filter the defects of these paper before the FFC calculation in order to not take them in account.

The command “lffw” set the intervals (+/-) around each pixel for the average calculation.

Each pixel is then compared to the average on the interval around it and replaced by this average if the difference is too high. With a filter value set at “X”, the calculation interval will be [-X , +X] around the pixel position.

A large interval value allows filtering big defects on the paper but finally the setting of this interval depends also on the magnification in the system.

7.8.1 Automatic Calibration

- **FFC Low Band Filter (*FFCAutoTargetLevel*)**: set the value for the User Target.
 - ⇒ Read function (ASCII): “**r lffw**”. Returns the Filter Interval size (from 0 to 32)
 - ⇒ Write function (ASCII): “**w lffw <value>**” : Set the Interval size for the filter (0 / 1 ... 32)
 - 0 : Disables the FFC Low Band Filter
 - 1 to 32 : Set the interval size (+/- the value around the pixel) for the Low Band filter

When you can’t provide a moving Target to the Camera during the PRNU Calibration you can setup the FFC Low Band Filter in order to remove the defect from the Target before calculating the FFC parameters. The Value set in the FFC filter defined the size of the interval around each pixel : The Filter will replace each pixel value by the average on the interval.



The FFC Low band filter is just an help to make in use the FFC (PRNU part) more easily : This can be done with a non-moving white paper as its defaults will be filtered in order to not being taken in account in the PRNU Correction.

Don’t forget to reset the filter (to “0”) after usage.

- **FPN/DSNU Calibration :**

- **FPN Calibration Control** (*FPNCalibrationCtrl*) : Launch or abort of the FPN process for the Offsets calculation. These commands are available in the CommCam “Flat Field Correction / Automatic Calibration ” section :

- ⇒ Read function (ASCII): “**r calo**” : Returns the FPN Calculation Process Status (0 if finished, 1 if processing)

- ⇒ Write function (ASCII):

- “**w calo 1**” : Launch the FPN Calibration Process.
- “**w calo 0**” : Abort the FPN Calibration Process.

- **FPN Coefficient Reset** (*FPNReset*) : Reset the FPN (Offsets) coefficient in Memory. This command is available in the CommCam “Flat Field Correction / Manual Calibration ” section :

- ⇒ Write function(ASCII) : “**w rsto 0**” : Reset (set to 0) the FPN coefficients in memory. This doesn’t affect the FFC User Memory Bank but only the active coefficients in Memory.

- **PRNU Calibration :**

- **PRNU Calibration Control** (*FFCCalibrationCtrl*) : Launch or abort of the PRNU process for the Gains calculation. This command is available in the CommCam “Flat Field Correction / Automatic Calibration ” section :

- ⇒ Read function : “**r calg**” (ASCII): Returns the PRNU Calculation Process Status (0 if finished, 1 if processing)

- ⇒ Write function (ASCII):

- “**w calg 1**” : Launch the PRNU Calibration Process.
- “**w calg 0**” : Abort the PRNU Calibration Process.

- **PRNU coefficient Reset** (*PRNUReset*) : Reset the PRNU (Gains) coefficient in Memory. This command is available in the CommCam “Flat Field Correction / Manual Calibration ” section :

- ⇒ Write function : “**w rstg 0**” (ASCII): Reset (set to “x1”) the PRNU coefficients in memory. This doesn’t affect the FFC User Memory Bank but only the active coefficients in Memory.



Some Warnings can be issued from the PRNU/FPN Calibration Process as “pixel Overflow” of “Pixel Underflow” because some pixels have been detected as too high or too low in the source image to be corrected efficiently.

The Calculation result will be proposed anyway as it’s just a warning message.

The Status Register is the changed and displayed in CommCam “Status” section :

Register status is detailed [chap §7.2](#).



How is performed the Flat Field Correction ?

What is the Flat Field correction (FFC) ?

The Flat Field Correction is a digital correction on each pixel which allows :

- To correct the Pixel PRNU (Pixel Response Non Uniformity) and DSNU (Dark Signal Non Uniformity)
- To Correct the shading due to the lens
- To correct the Light source non uniformity

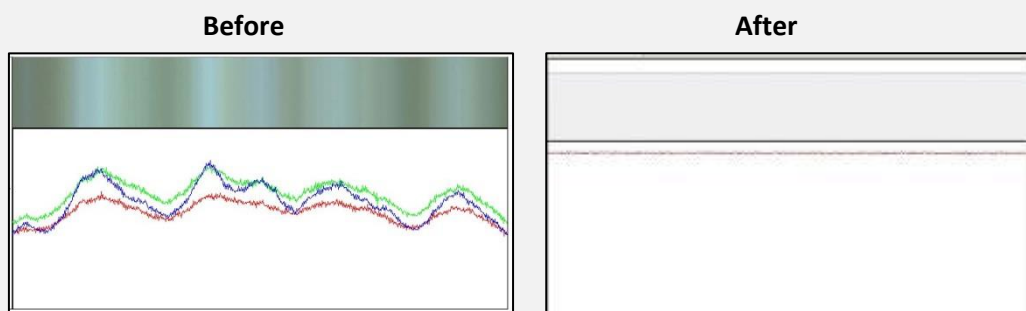

How is calculated / Applied the FFC ?

The FFC is a digital correction on the pixel level for both Gain and Offset.

Each Pixel is corrected with :

- An Offset on 10 bits (Signed Int S9.1). They cover a dynamic of ± 256 LSB in 12bits with a resolution of 1/2 LSB 12bits. Offset : the MSB is the sign, the rest of 9bits is from 0 .. 256 with precision of 1/2
- A Gain on 12 bits (Unsigned Int U1.13) with a max gain value of **x4.999**

The calculation of the new pixel value is : $P' = (P + \text{Off}) \cdot (1 + \text{Gain}/1024)$. Gain : 0 to 4095

The FFC processing can be completed with an automatic adjustment to a global target. This function is designed as “**FFC Adjust**”. This adjustment to a User target is done by an internal hidden gain which is re-calculated each time the FFC is processed while the FFC adjust function is enabled.

The FFC is always processed with the max pixel value of the line as reference. If enabled, the FFC adjust module (located at the output of the FFC module) calculates the adjustment gain to reach the target defined by the User.

When the FFC result is saved in memory, the adjust gain and target are saved in the same time in order to associate this gain value with the FFC result.

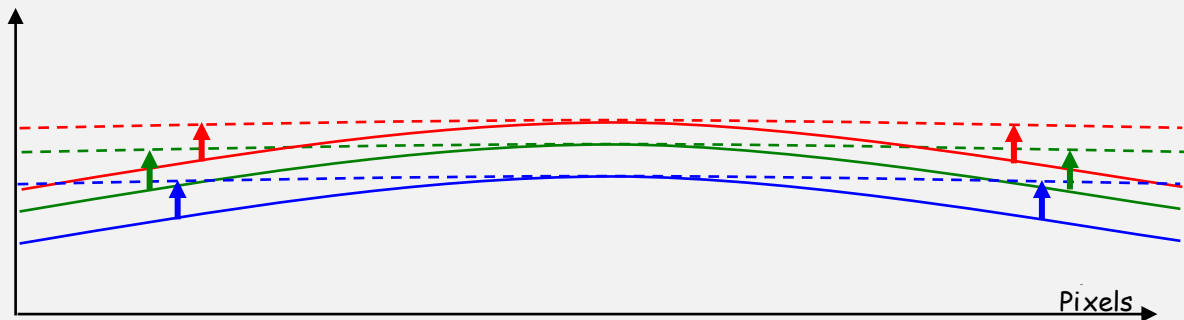

Standard FFC computed on the max of the line for each color (Green_{Blue} and Green_{Red} are treated separately). Then the White Balance will overlay the colors

How to perform the Flat Field Correction ?

FPN/DSNU Calibration

- Cover the lens
- Launch the FPN Calibration : Grab and calculation is performed in few seconds

PRNU Calibration

The User must propose a white/grey uniform target to the Camera (not a fixed paper). The Gain/Light conditions must give a non saturated image in any Line. The Camera must be set in the final conditions of Light/ Gain and in the final position in the System.

If required, set a user target for the FFC adjust and enable it.

- White uniform (moving) target. Use The FFC Low Band Filter if the Target can't move. This will remove the defects of the target itself
- Launch the FFC
- Enable the FFC
- You can save the FFC result (both FPN+PRNU in the same time) in one of the 4 x FFC User Banks.
- The user target and Gain are saved with the associated FFC in the same memory.
- Remove the FFC Low Band filter (set to 0) if used during the Process.

Advices

The UNIIQA+ Cameras have 4 x FFC Banks to save 4 x different FFC calibrations. You can use this feature if your system needs some different conditions of lightning and/or Gain because of the inspection of different objects : You can perform one FFC to be associated with one condition of Gain/setting of the Camera (4 Max) and recall one of the four global settings (Camera Configuration + FFC + Line Quarters Balance) when required.

7.8.2 Manual Flat Field Correction

The FFC Coefficients can also be processed outside of the Camera or changed manually by accessing directly their values in the Camera : This is the “Manual” FFC.

In CommCam, the User can access to a specific interface by clicking on “click for extended control” in both “Manual FFC calibration” and “Manual FPN calibration sections” :

This will allow the user to upload/download out/in the Camera the FFC coefficients in/from a binary or text file that can be processed externally.



It is recommended to setup the baud rate at the maximum value possible (230400 for example) otherwise the transfer can take a long time.

- **Set FFC Address memory access** : Set the memory address for the direct access to both PRNU/ FPN coefficients for reading or writing. After each read or write action, this address is incremented of 128
 - ⇒ Write function (ASCII):” **w ffcga <addr>** : Set the address in memory for the next read/write command of the PRNU/FPN Coefficients.
 - Start address for Offsets (FPN) : 0x12400
 - Start address for Gains (PRNU) : 0x13400
 - . **<addr>** auto increments automatically after each write command.

- **FPN coefficients modification** : Direct access to the FPN coefficients for reading or writing. The FPN coefficients are read packets of x128 coefficients :
 - ⇒ Read function (ASCII):” **r ffco**” : Read 128 consecutive FPN user coefficients starting from address set by the command **fccga**. Returned value is in hexadecimal, without space between values (2 Bytes per coefficient).
 - <addr>** auto increments automatically after each read command.
 - Write function (ASCII):” **w ffco <val>** : Write 128 consecutive FPN user coefficients starting address set by the command **fccga**. **<val>** is the concatenation of individual FPN values, without space between the values (2 Bytes per coefficient). **<addr>** auto increments automatically after each write command.

- **PRNU coefficients modification** : Direct access to the PRNU coefficients for reading or writing.
The PRNU coefficients are read packets of x128 coefficients :
 - ⇒ Read function (ASCII): “**r ffcg**” : Read 128 consecutive PRNU user coefficients starting from address set by the command **fcca**. Returned value is in hexadecimal, without space between values (2 Bytes per coefficient).
<addr> auto increments automatically after each read command.
 - ⇒ Write function (ASCII): “**w ffcg <val>**” : Write 128 consecutive PRNU user coefficients starting from address set by the command **fcca**. **<val>** is the concatenation of individual PRNU values, without space between the values (2 Bytes per coefficient).
<addr> auto increments automatically after each write command.

7.9 Save & Restore FFC and Configuration User set

GenCP address	ASCII command	GenICam command	Size	R/W	Description
0x17000	rcfg	UserSetLoad	4	RW	Restore current UserSet from UserSet bank number <val>, from 0 to 5; <val> comes from UserSetSelector.
0x17004	scfg	UserSetSave	4	WO	Save current UserSet to UserSet bank number <val>, from 1 to 4; <val> comes from UserSetSelector. 0 cannot be saved.
0x17008	rffc	RestoreFFCFromBank	4	RW	Restore current FFC (including FPN and FFCGain) from FFC bank number <val>, from 0 to 4; <val> comes from UserFFCSelector (XML feature). Bank#[0] are FFC sensor Bank#[1-4] are FFC user
0x1700C	sffc	SaveFFCToBank	4	WO	Save current FFC (including FPN and FFCGain) to FFC bank number <val>, from 1 to 4; <val> comes from FFCSelector (XML feature).

7.9.1 Save & Restore FFC

The new-processed FFC values can be saved or restored in/from 4 x User banks.

Both Gains and Offsets in the same time but also the FFC Adjust User target and associated gain.

These functions are available in the Flat Field correction/Save & Restore FFC section :

- **Restore FFC from Bank** (*RestoreFFCFromBank*) : Restore the FFC from a Bank in the current FFC.
 - ⇒ Read function : “**r rffc**” (ASCII): Get the current FFC Bank used
Returned by the camera : 0 for Factory bank or 1 to 4 for User banks
 - ⇒ Write function : “**w rffc <val>**” (ASCII): Bank <val> 1 to 4 for User banks
Note : Factory means neutral FFC (no correction).
- **Save FFC in User Bank** (*SaveFFCToBank*) : Save current FFC in User Bank
 - ⇒ Can not de read
 - ⇒ Write function : “**w sffc <val>**” (ASCII): User bank <val> if from 1 to 4.

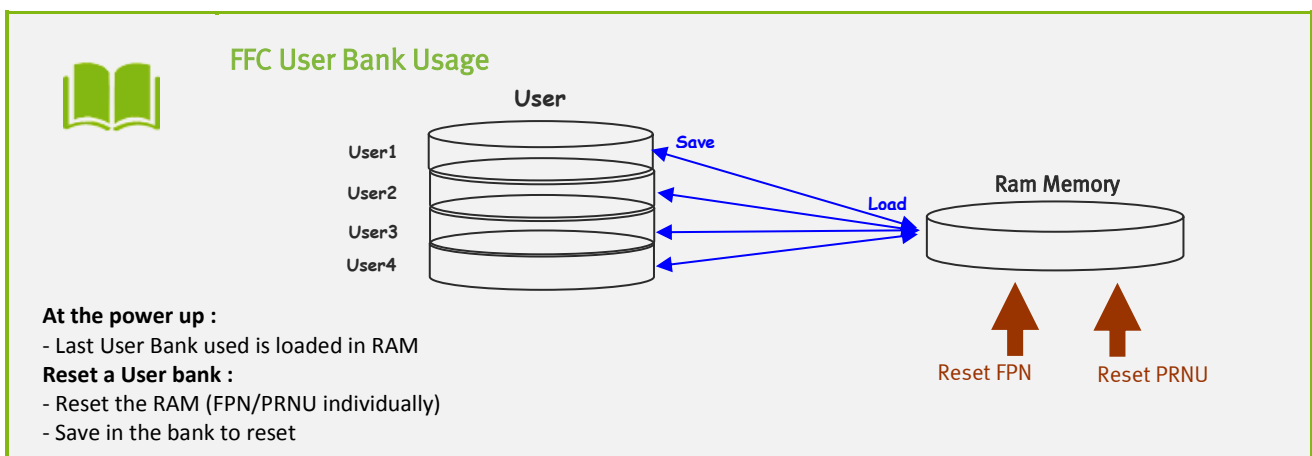

7.9.2 Save & Restore Settings

The settings (or Main configuration) of the Camera can be saved in 4 different User banks and one Integrator bank. This setting includes also the FFC and LUT enable

This function is available in the Save & Restore Settings section :

- **Load settings from Bank** : Allows to restore the Camera settings.
 - ⇒ Read function : “**r rcfg**” (ASCII): Get the current Tap Bank in use
 - ⇒ Write function : “**w rcfg <val>**” (ASCII): Load settings from bank <val> (0: Factory , 1 to 4 for Users, 5 for Integrator)
- **Save settings to Bank** : Allows to save the Camera settings in User or Integrator Bank
 - ⇒ Write function : “**w scfg <val>**” (ASCII): Save the current settings in the User bank <val> (1 to 4 for User, 5 for Integrator)



The integrator bank (User Set5) can be written only if the Camera is set in integrator mode (Privilege level = 1). This integrator bank can be used as a « Factory default » by a system integrator.



Configuration Bank Usage

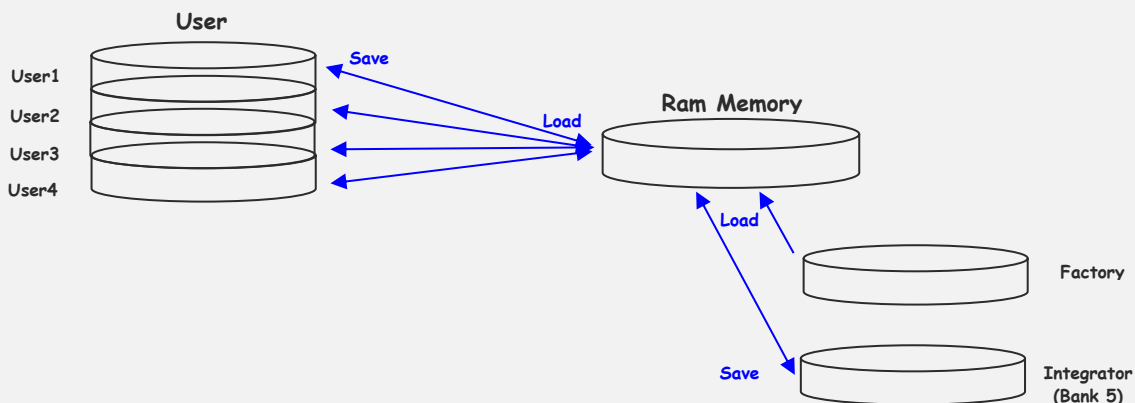

APPENDIX

Appendix A. Test Patterns

The Main test pattern is a fixed ramp (Monochrome) from first pixel (value 0) to the last one (value 4095)



A.1 4k Pixels, 12bits

Increment of 1 grey level at each pixel :

Pixel	0	1	2	3	4093	4094	4095
Value	0	1	2	3	4093	4094	4095

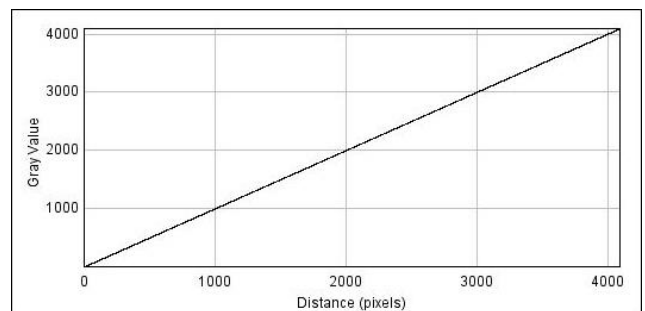

A.2 2k Pixels, 12bits

Increment of 2 grey level at each pixels :

Pixel	0	1	2	3	2045	2046	2047
Value	0	2	4	6	4090	4092	4094

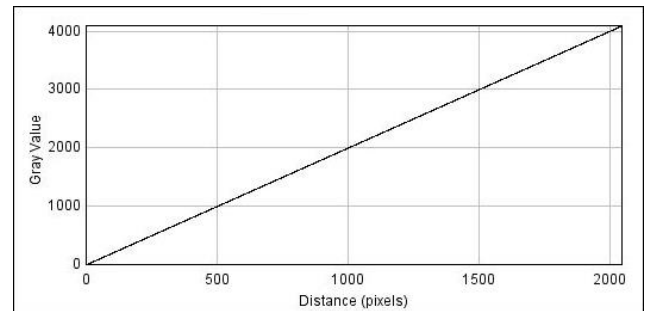

A.3 1k Pixels, 12bits

Increment of 4 grey level at each pixels :

Pixel	0	1	2	3	1020	1022	1023
Value	0	4	8	12	4084	4088	4092

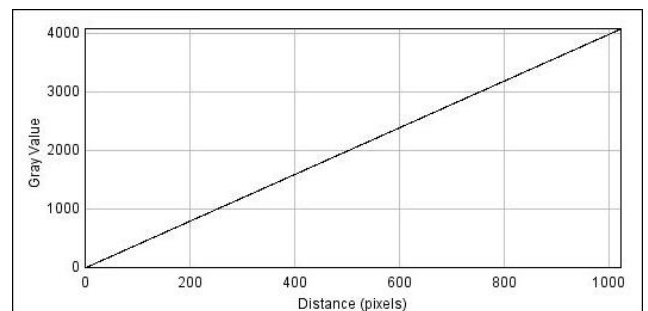

A.4 1k Pixels, 12bits

Increment of 8 grey level at each pixels :

Pixel	0	1	2	3	509	510	511
Value	0	8	16	24	4072	4080	4088

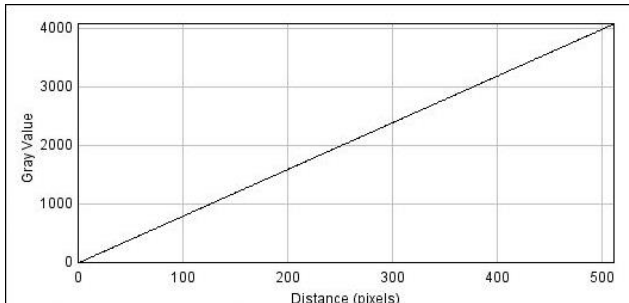

Appendix B. Timing Diagrams

B.1 Synchronization Modes with Variable Exposure Time

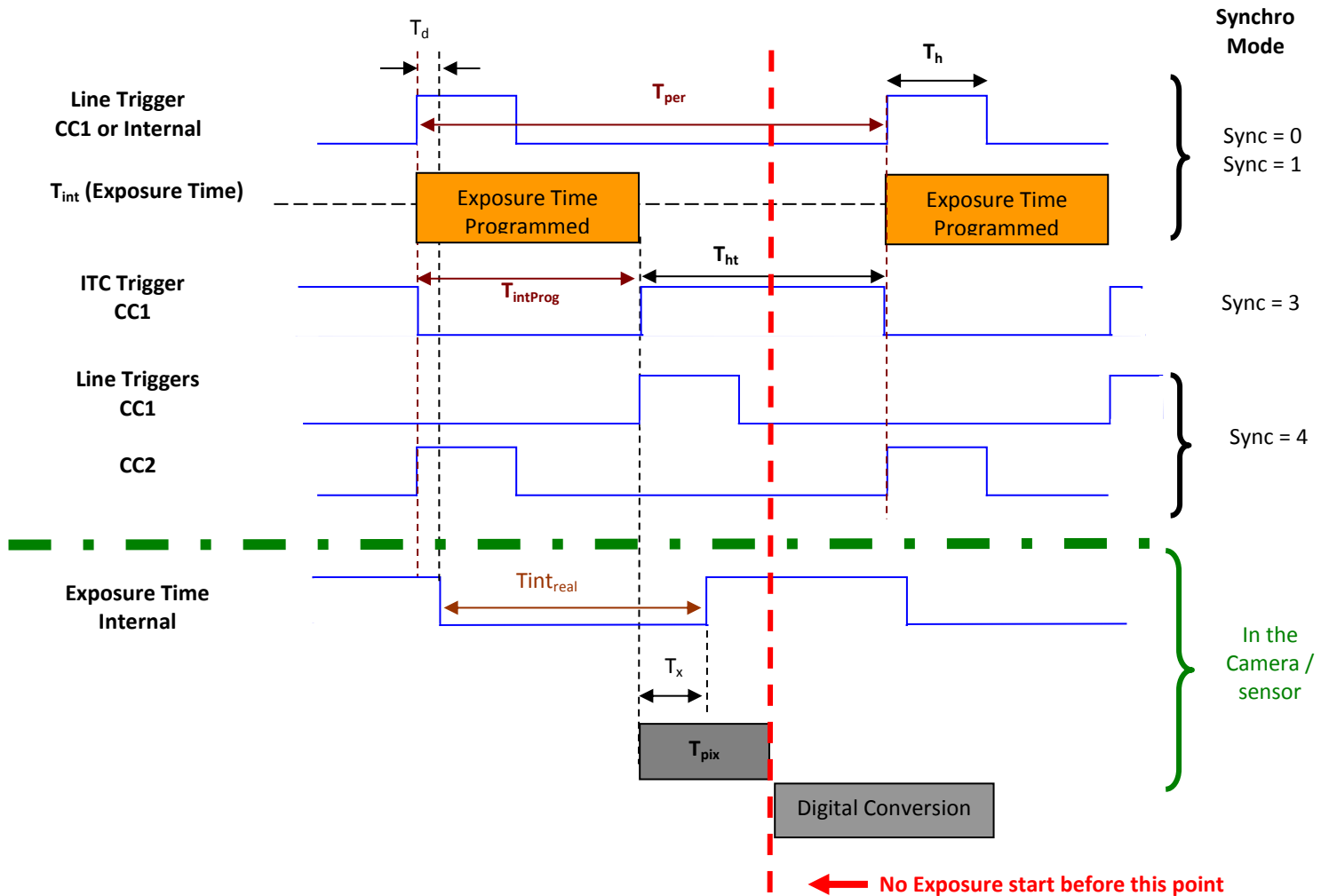

T_{pix} : Timing Pixel. During this uncompressible period, the pixel and its black reference are read out to the Digital converter. During the first half of this timing pixel (read out of the black reference), we can consider that the exposure is still active.

Digital Conversion : During the conversion, the analog Gain is applied by the gradient of the counting ramp (see next chapter : Gain & Offset). The conversion time depends on the pixel format :

- 8 or 10 bits : **6 μ s**
- 12 bits : **24 μ s**

This conversion is done in masked time, eventually during the next exposure period.

T_d : Delay between the Start exposure required and the real start of the exposure.



If T_{per} is the Line Period (internal or external coming from the Trigger line), in order to respect this line Period, the Exposure Time as to be set by respecting : $T_{int} + T_{pix} \leq T_{per}$

Then, the real exposure time is : $T_{int_{real}} = T_{int} + T_x - T_d$.

In the same way, The high level period of the Trig signal in sync=3 mode, $T_{ht} \geq T_{pix}$

For a Line Period of $LinePer$, the maximum exposure time possible without reduction of line rate

is : $T_{int_{max}} = T_{per} - T_{pix}$ (T_{pix} is defined above) but the effective Exposure Time will be about

$T_{int_{real}} = T_{int} + T_x - T_d$.

B.2 Synchronisation Modes with Maximum Exposure Time

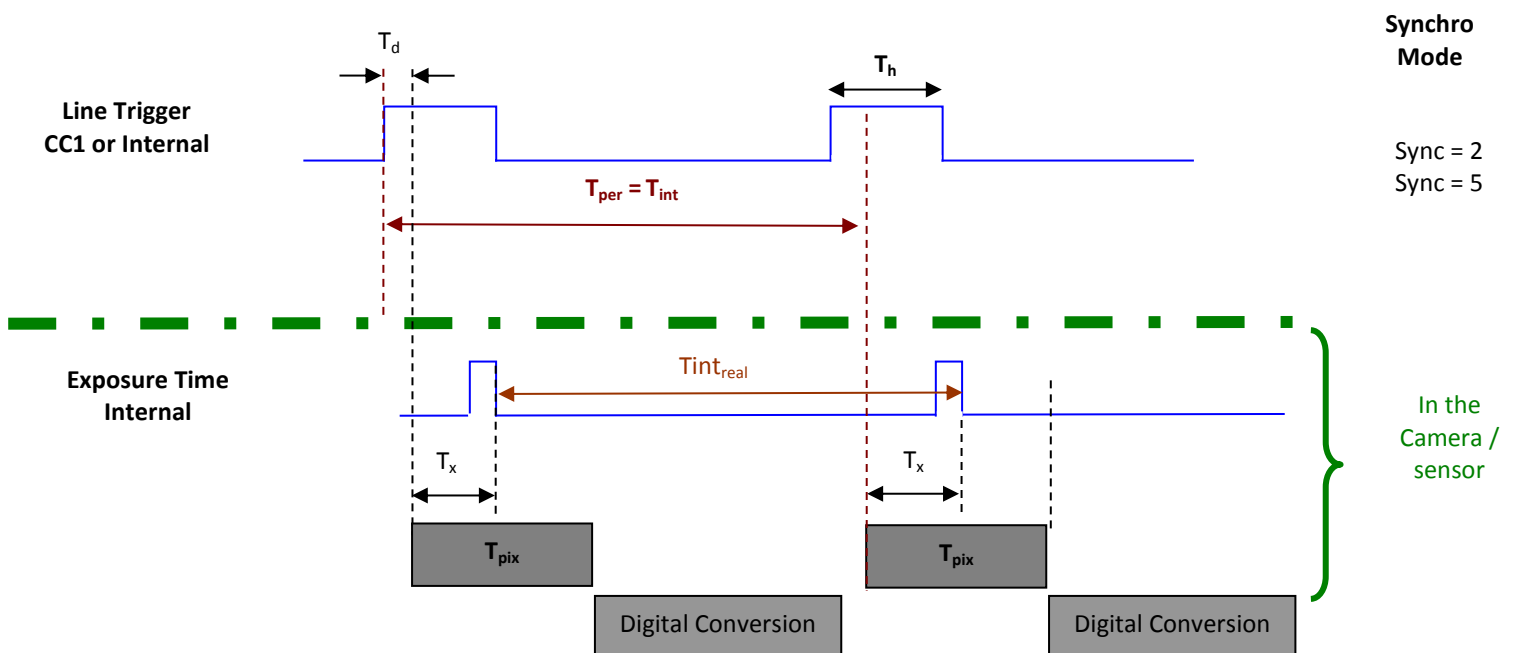

In these modes, the rising edge of the Trigger (internal or External) starts the readout process (T_{pix}) of the previous integration. The Real exposure time ($T_{int_{real}}$) is finally equal to the Line Period (T_{per}) even if it's delayed from ($T_x + T_d$) from the rising edge of the incoming Line Trigger.

B.3 Timing Values

Label	Min	Unit
T_{pix}	2.7	μs
T_x	1.26	μs
T_h	0.120	μs
T_{ht}	T_{pix}	μsec
T_d	0.7	μs

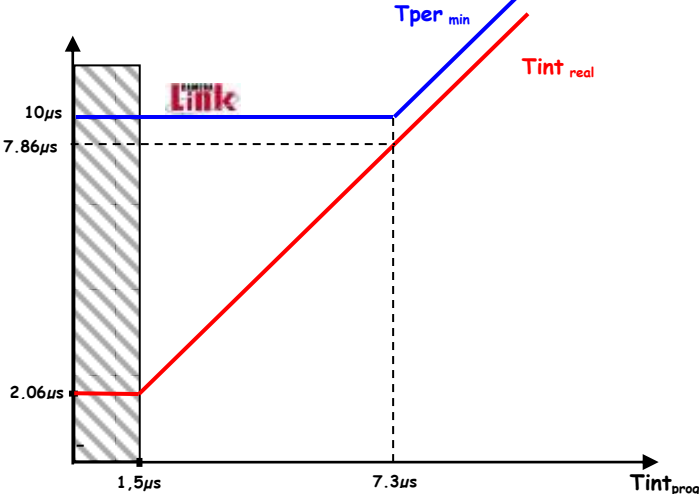

Appendix C. CameraLink Data Cables

C.1 Choosing the Cable

You may check the compliance of your CameraLink cables with the transportation of the 85MHz data rate.

The main parameter to be checked in the cable specification is the skew (in picoseconds)

This parameter is given for a dedicated maximum value per meter of cable (as max : 50ps/m)

The CameraLink Standards defines the maximum total skew possible for each data rate :

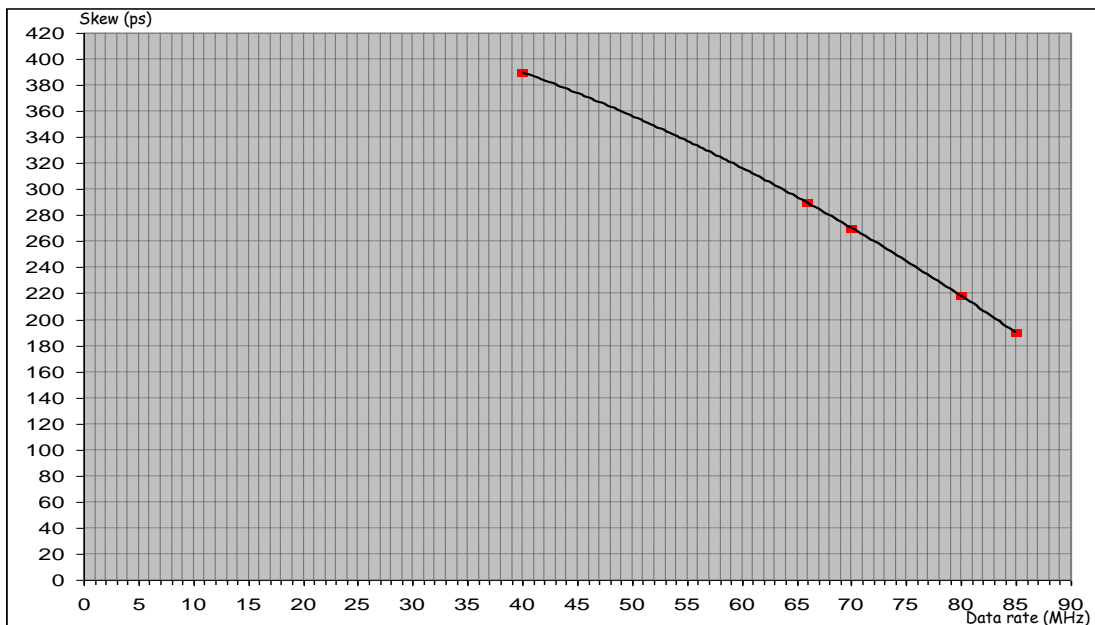

Here is a following example of cable and the cable length limitation in accordance with the standard :

Conductor Size:	28 AWG Stranded
Propagation Velocity:	1.25 ns/ft [4.1 ns/m]
Skew (within pair):	50 ps/meter maximum
Skew (channel skew per chipset):	50 ps/meter maximum

<u>DataRate</u>	<u>Skew</u>	<u>Cable Length</u>
40Mhz	390ps	7,8m
66MHz	290ps	5,8m
70MHz	270ps	5,4m
80MHz	218ps	4,36m
85MHz	190ps	3,8m

C.2 Choosing the Data Rate

Maximum Line Rates tables versus Data rate and Definition

C.2.1 High Speed Models

Data Frequency : 85MHz				
Definition	Base		Medium	
	Line Rate Max (kHz)	Tper Min (μ s)	Line Rate Max (kHz)	Tper Min (μ s)
4096 Pixels	20	50	40	25
2048 Pixels	40	25	80	12.5
1024 Pixels	80	12.5	100	10
512 Pixels	100	10	100	10

Data Frequency : 60MHz				
Definition	Base		Medium	
	Line Rate Max (kHz)	Tper Min (μ s)	Line Rate Max (kHz)	Tper Min (μ s)
4096 Pixels	13.8	72	27.7	36
2048 Pixels	27.7	36	55.5	18
1024 Pixels	55.5	18	100	10
512 Pixels	100	10	100	10

Data Frequency : 42.5MHz				
Definition	Base		Medium	
	Line Rate Max (kHz)	Tper Min (μ s)	Line Rate Max (kHz)	Tper Min (μ s)
4096 Pixels	10	100	20	50
2048 Pixels	20	50	40	25
1024 Pixels	40	25	80	12.5
512 Pixels	80	12.5	100	10

C.2.2 Essential Models

Data Frequency : 85MHz		
Definition	Base	
	Line Rate Max (kHz)	Tper Min (μs)
4096 Pixels	20	50
2048 Pixels	40	25
1024 Pixels	40	25
512 Pixels	40	25

Data Frequency : 60MHz		
Definition	Base	
	Line Rate Max (kHz)	Tper Min (μs)
4096 Pixels	13.8	72
2048 Pixels	27.7	36
1024 Pixels	40	25
512 Pixels	40	25

Data Frequency : 42.5MHz		
Definition	Base	
	Line Rate Max (kHz)	Tper Min (μs)
4096 Pixels	10	100
2048 Pixels	20	50
1024 Pixels	40	25
512 Pixels	40	25

Appendix D. Lens Mounts

D.1 F-Mount



F Mount: (Part number EV50-MOUNT-F)

Drawing for the additional part (except Nikon BR3) :

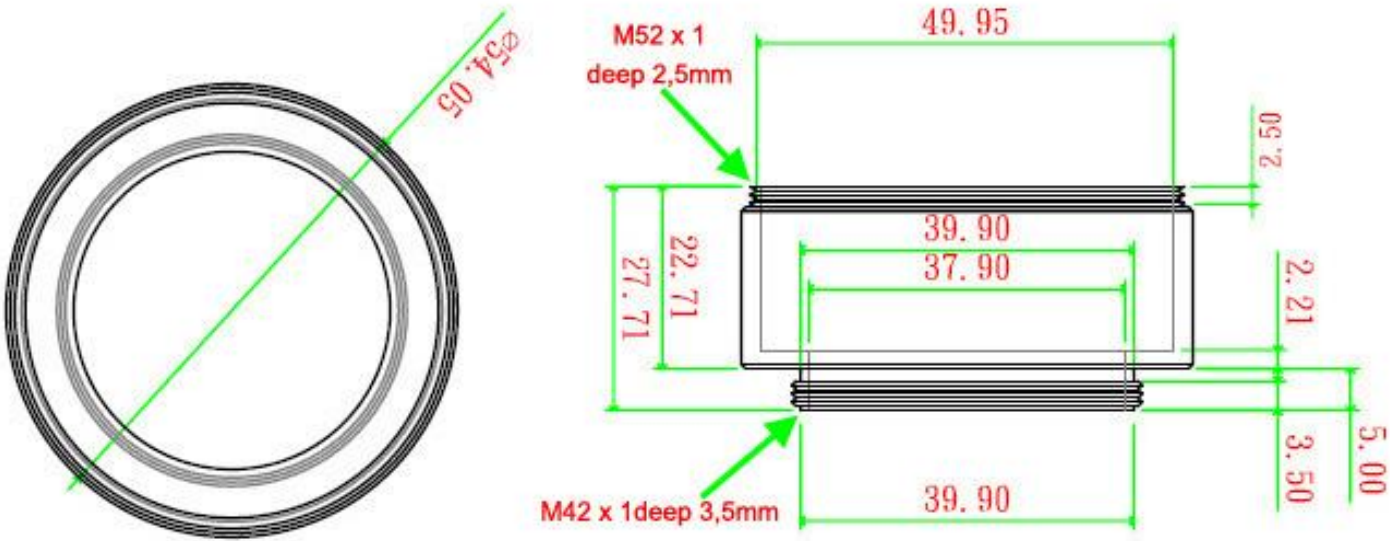

D.2 C-Mount



C Mount : (Part number EV50-MOUNT-C)

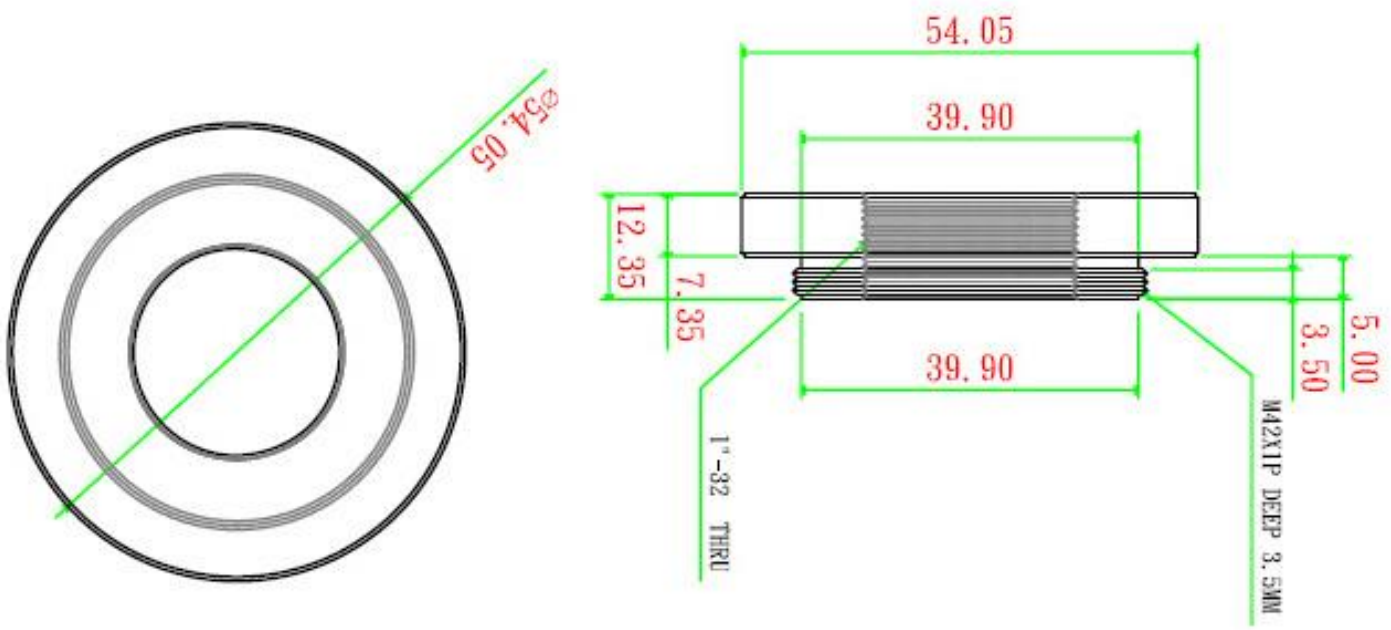

Appendix E. CommCam Connection

The Frame Grabber has to be compliant with Camera Link 1.1

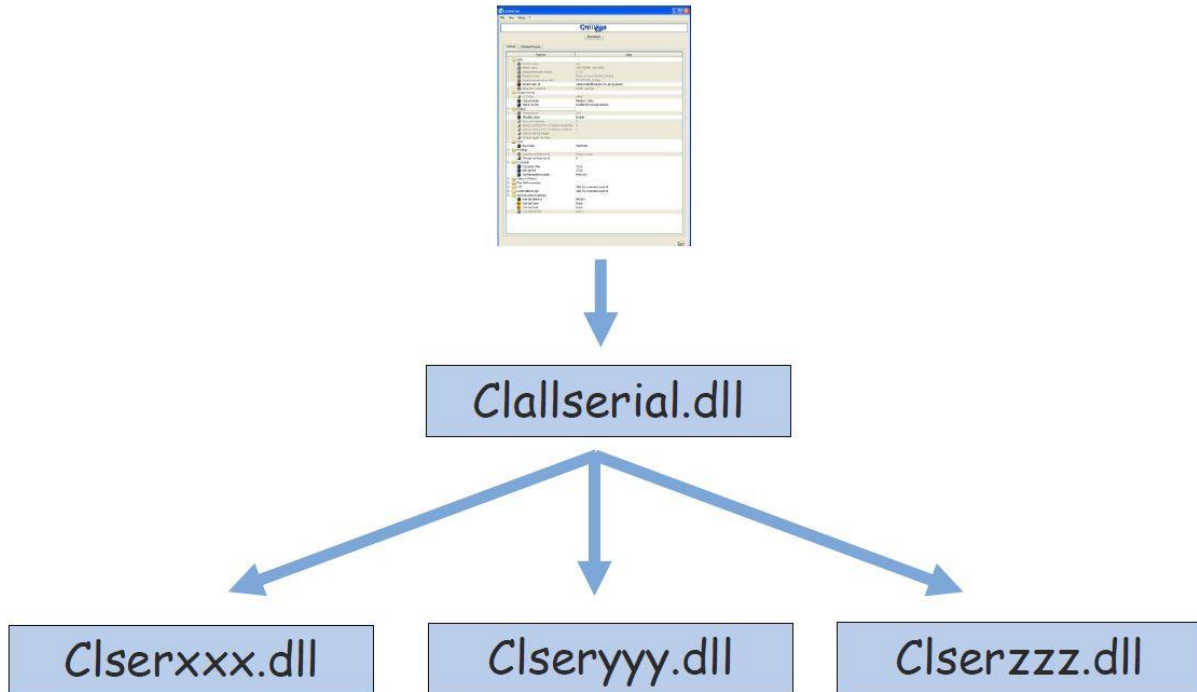



Clallserial.dll (Standard CameraLink Services Library)

- In 32bits : Must be located in : program files\CamerLink\serial and location added to PATH variable
- In 64bits : Must be located in : program files\CamerLink\serial or
 - For 32bits version : Must be located in : program files(x86)\CamerLink\serial and both locations added to PATH variable

Clserxxx.dll (FG Manufacturer dedicated CameraLink Services Library)

- **In 32bits** : in the directory defined by the Register Key :
CLSERIALPATH (REG_SZ) in HKEY_LOCAL_MACHINE\software\cameralink
The directory should be program files\CamerLink\serial or any other specified
- **In 64bits, for a 64bits version** : in the directory defined by the Register Key : CLSERIALPATH (REG_SZ) in HKEY_LOCAL_MACHINE\software\cameralink
The directory should be program files\CamerLink\serial or any other specified
- **In Windows 64bits, for a 32bits version** : in the directory defined by the Register Key : CLSERIALPATH (REG_SZ) in HKEY_LOCAL_MACHINE\Wow6432Node\software\cameralink
The directory should be program files(x86)\CamerLink\serial or any other specified

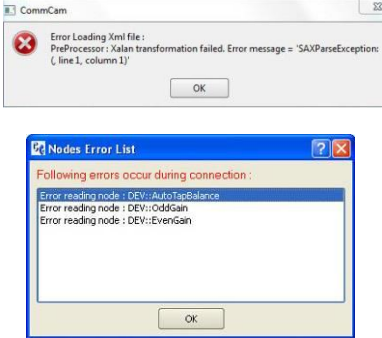
Defect	Detail	Solutions
<p><u>CommCam Can't find the Camera :</u></p> <p>After launching CommCam, the Icon of the Camera is not visible.</p>		<ul style="list-style-type: none"> ▪ The Camera is not powered up or the boot sequence is not finished. ▪ The CameraLink cable is not connected or connected on the bad connector. ▪ Check if the CameraLink libraries (clallserial.dll and clserXXX.dll) are in the same directory (either <i>system32</i> or <i>program files/cameralink/serial</i>) ▪ The Frame Grabber is compliant with CameraLink standard 1.1 <ul style="list-style-type: none"> > Contact the hotline : hotline-cam@e2v.com
<p><u>An e2v Camera is detected but not identified :</u></p> <p>A “question Mark” icon appears in place of the one of the AVIIVA2</p>		<ul style="list-style-type: none"> ▪ The version of CommCam used is too old : You have to use the version 1.2.x and after.
<p><u>Impossible to connect to the identified Camera :</u></p> <p>The message “Impossible to open device” is displayed</p>		<ul style="list-style-type: none"> ▪ There is a possible mismatch between the major version of xml file used by CommCam and the firmware version of the Camera ▪ Possible Hardware error or Camera disconnected after being listed. <ul style="list-style-type: none"> > Contact the hotline : hotline-cam@e2v.com
<p><u>Error messages is displayed just after/before the connection :</u></p>		<ul style="list-style-type: none"> ▪ There is a possible mismatch between the minor version of xml file used by CommCam and the firmware version of the Camera ▪ Default values of the Camera out of range <ul style="list-style-type: none"> > Contact the hotline : hotline-cam@e2v.com

Appendix F. Revision History

Manual Revision	Comments / Details	Firmware version	1 st CommCam compliant Version
Rev A	First release	1.1.1	2.4.3
Rev B	Changing directive EMC	1.1.1	2.4.3
Rev C	New Template for Documentation LowPass Filter Width increased New GenCP Addresses for FFC Coeff CL Frequency available in 40MHz	1.3.0	2.5.1
Rev D	Documentation correction (Max Line Rates)	1.3.0	2.6.0