

Vincent Associates 803 Linden Avenue, Rochester, NY 14625
 web www.uniblitz.com e-mail vincentassociates@uniblitz.com toll-free 800.828.6972

FEATURES

- Small form factor, a 65 mm aperture fits into a 5-inch diameter housing!
- Multi-bladed design in combination with the UNIBLITZ® actuator provide increased speed over other designs of this type.
- State of the art patented damping system for increased reliability and speed.
- Minimum exposure time exceeds that of the VS65!
- Reflective blades available for laser and non-coherent light sources, "S", "Z" and "ZM" Type.
- Can be driven with our existing VCM/VMM drive units. Special driver not required.
- Available housed or un-housed for OEM applications.
- #102 Mounting Ring available for universal mounting applications.
- Electronic Synchronization System option available.
- Exposure repetition rates from DC to 5 Hz.
- Design, accuracy, and reliability that you have come to know as with all other UNIBLITZ products!
- Can be configured normally open

The CS65 is the second release in the new UNIBLITZ® CS series. The small form factor allows a 65 mm aperture to be installed into applications not presently accessible with existing UNIBLITZ VS series shutters. As with the CS45, the CS65 has been designed to provide accurate, repeatable exposures for a wide variety of applications. The small form factor allows a 65 mm aperture to be installed into a five-inch diameter housing – about the same overall size as the existing VS35 shutter! To increase the unit's flexibility, the shutter can be supplied in an un-housed version for OEM applications or in situations inaccessible to most shutters due to spatial limitations.

The CS65, along with its state-of-the-art patented damping system, provides increased reliability over other designs of its type. In addition, the system provides the reliable actuator system found in all other UNIBLITZ shutter designs allowing it to be driven with our existing VCM/VMM drive units. As an option, the shutter can be equipped the electronic synchronization system.

When gating high intensity light sources, the CS65 can be equipped with polished stainless steel reflective blades. This option protects the shutter blades from the light source's damaging effects by reflecting the energy away from the blade surface. Look for future availability of "Z" (AlSiO) and "ZM" (AlMgF₂) coated blades in this device.

To further enhance the flexibility of the CS65; an optional #102 mounting ring is available to allow the shutter to be easily mounted in many non-specific applications. Additional information regarding the #102 mounting ring can be found in the specific data sheets entitled "MICROSCOPE, VIDEO and UNIVERSAL MOUNTING SYSTEMS" or on-line under "products", "Mounting Systems".

¹ Voltage level required across actuator coil when being held in the open position.
² Dual hold level driver system included in UNIBLITZ VMM shutter controller.
³ CONTinuous frequency rating specified at shutter's minimum exposure pulse. BURST frequency rating specified for (4) four seconds maximum with (1) one minute minimum between bursts. Frequency measurements are taken in free air, 25°C ambient, actuator coil equipped with heat sink. For additional information on maximum sustained frequencies obtainable, please contact one of our technical representatives.

ELECTRICAL

Coil Resistance	12 ohms
Pulse Voltage to Open	+70VDC
Hold Voltage ¹	+7VDC/+5VDC ²

MECHANICAL

Wgt. Un-Cased	4.0 oz (.112 kg)
Wgt. Cased	13.2 oz (.374 kg)
Operating Temp.	0°C to +80°C
Max. Opening Bounce	15%
Max. Closing Bounce	5%
Max. Frequency of Operation (CONT/BURST) ³	2 Hz / 5 Hz
Number of Blades	6

TIMING

Typical timing values (msec.) using UNIBLITZ drive equipment and measured with UNIBLITZ shutters equipped with standard TEFLON® coated shutter blades.

TIMING OF PULSE INPUT AND SYNCHRONIZATION OUTPUT RELATIVE TO SHUTTER STATE

TYPICAL PULSE INPUT TO CONTROLLER

SHUTTER STATE

TYPICAL ELECTRONIC SYNCHRONIZATION OUTPUT FROM CONTROLLER

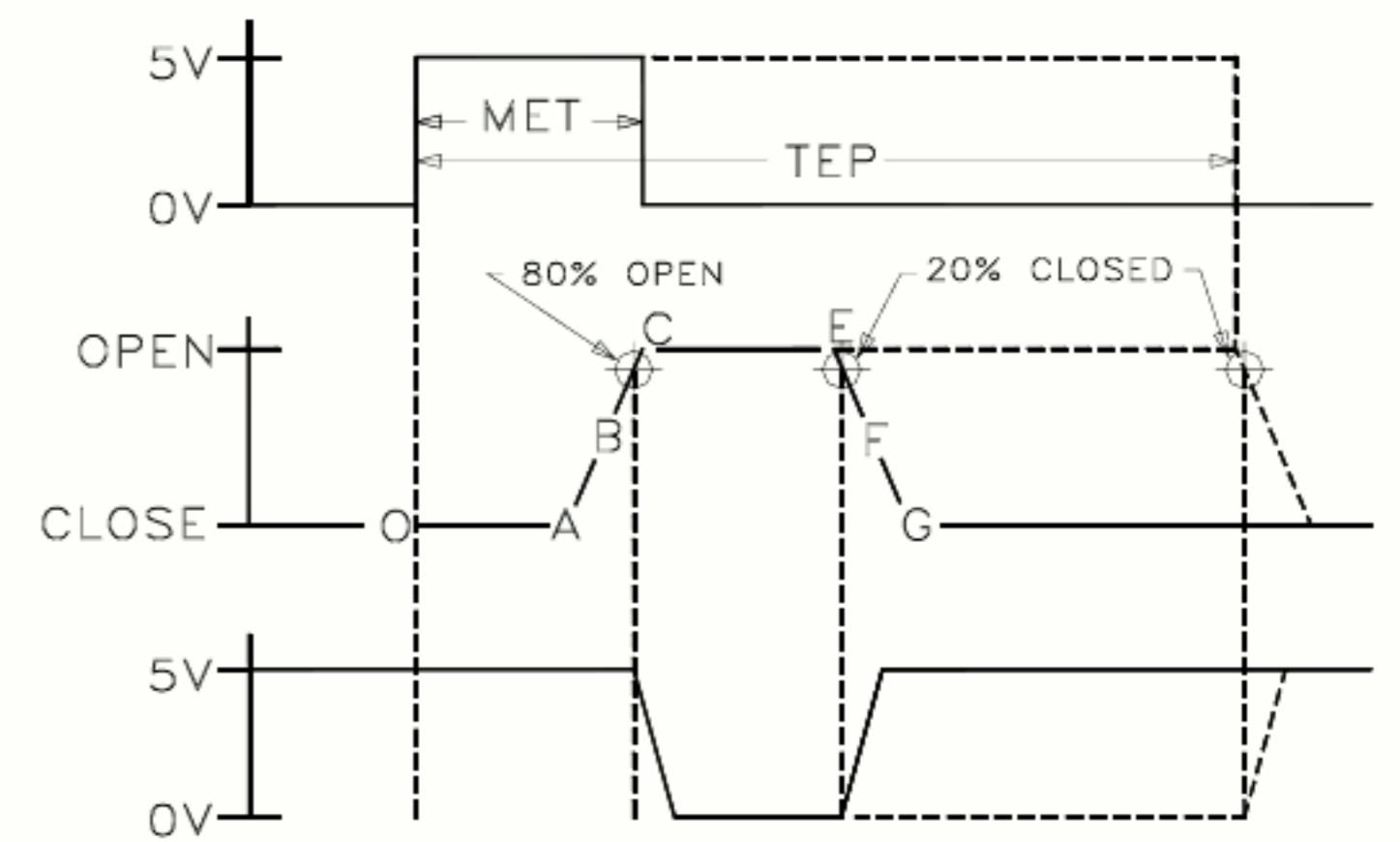

(Timing in msec.)

O-A Delay time on opening after current is applied	6.0
A-C Transfer time on opening	29.0
O-C Total opening time	35.0
B-F Min. equivalent exp. time	60.0
C-E Min. dwell time with min. input pulse	18.0
E-G Transfer time on closing	55.0
A-G Total window time	102.0

MET: Min. exposure time	40.0
TEP: Typical exposure pulse	>40.0

The question regarding enhancement of shutter speed with the application of user supplied lubricants has been repeatedly asked. It is our experience that lubricating the shutter blades will actually slow the shutter down and eventually render the shutter inoperable. UNDER NO CIRCUMSTANCES SHOULD ANY TYPE OF LUBRICANT BE APPLIED TO THE SHUTTER BLADE AREA.

PRODUCT OPTIONS

CS65S 3 T 0 R3 -102

Aperture Size	Housing	Blade Finish	Electronic Sync.	High Temp Mod	Mounting Options
CS65S - 65mm	1 - Un-housed 3 - #3 Housing	T - Teflon® Coated S.S. Blades S - Polished Stainless Steel Blades* ZM - AlMgF ₂ Coated BeCu Blades* Z - AlSiO Coated BeCu Blade	0 - Omit Sync. 1 - Electronic Sync. Included	R3 - High Temp Modification (Omit R3 Designation if Not Required)	-102 Mounting Ring

UN-CASED STYLE

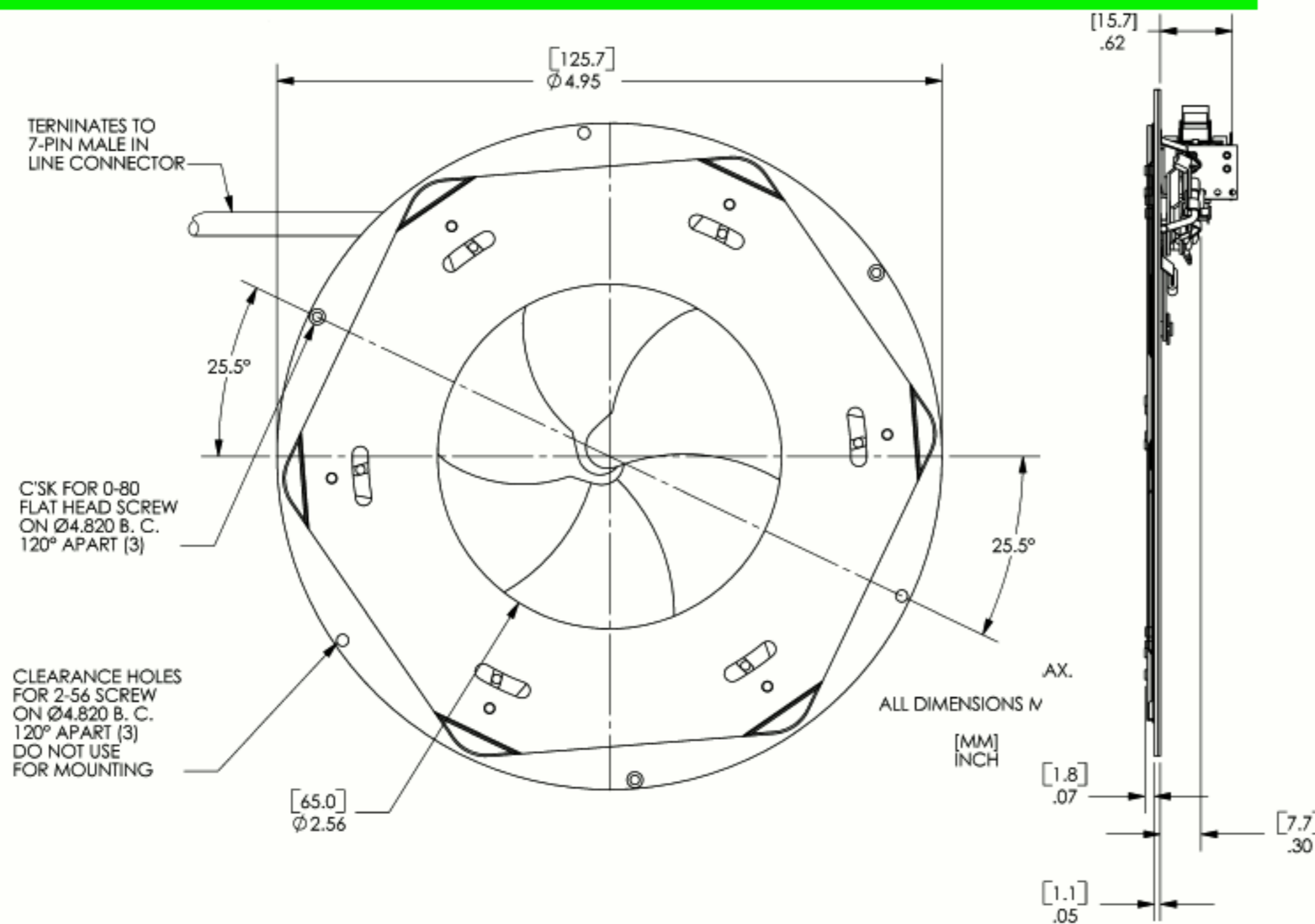

The CS65 un-housed style is the basic configuration of this device and is best suited for OEM applications. Mounting can be accomplished through three 0-80 (flat head required) clearance holes located around the unit's perimeter on a 4.820 inch diameter bolt circle. These holes, as indicated, are 120 degrees apart. Unless otherwise specified, this standard unit is terminated to a 7-pin male connector through a 7-wire six-inch cable assembly. (The three 2-56 holes are not recommended for mounting due to the potential for interference with the shutter's blades.)

CASED STYLE

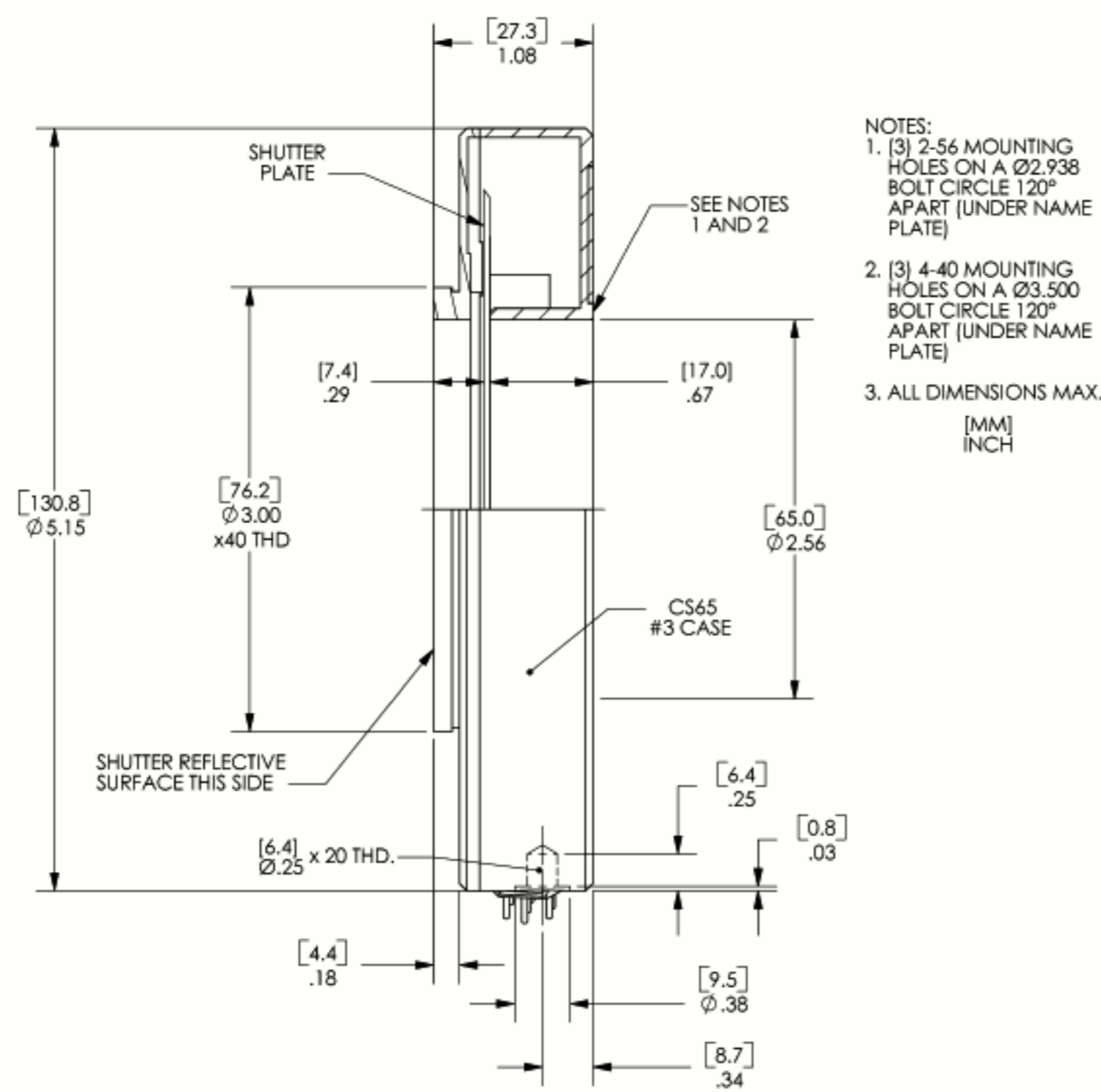

The CS65 #3 housing style allows a number of mounting configurations. A 1/4-20 threaded hole is provided for post mounting. The 3.00inch x 40TPI external thread located on the rear side, and the specific mounting holes located on the front side (see Figure #2 and Figure #3) can be interfaced directly into your application or fitted with a variety of user specific mounting options. For the CS65, the #102 Mounting Ring is presently the only mounting option available. Additional information regarding the #102 mounting ring can be found in the specific data sheet entitled "UNIVERSAL MOUNTING SYSTEMS" or on-line under "products", "Mounting Systems". The unit terminates with a 7-pin male connector as illustrated.

This drawing illustrates 7-pin connector and 1/4-20 threaded hole layout for the CS65 series #3 housed style.

HOUSING/CONNECTOR LAYOUT

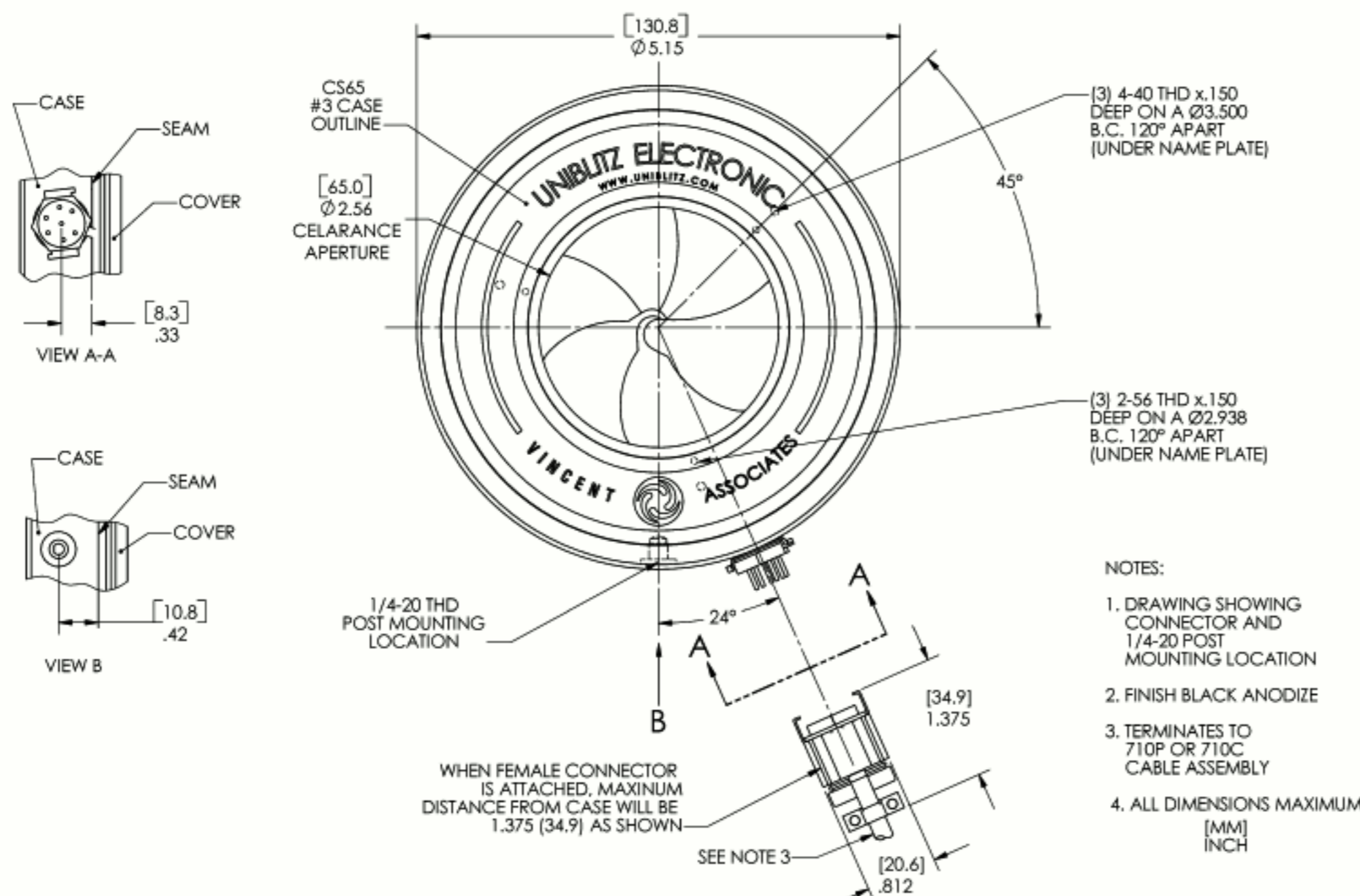

Due to our ongoing product development program, Vincent Associates reserves the right to discontinue or change specifications or designs at any time, without incurring any obligations. Teflon is a registered trade mark of E.I. Dupont U. S. Pat. No. 3,427,576; 3,595,553; 3,967,293; 6,652,165. Drawing shown for illustrative purposes only. Updated 07/2004.