

CS90 SHUTTER PRELIMINARY SPECIFICATIONS



Vincent Associates 803 Linden Avenue, Rochester, NY 14625
 web www.uniblitz.com e-mail vincentassociates@uniblitz.com toll-free 800.828.6972

FEATURES

- Small form factor, a 90 mm aperture fits into a 7-inch diameter housing!
- Six-bladed design in combination with the UNIBLITZ actuator, and a state of the art damping system provide increased reliability over other designs of this type.
- Reflective stainless steel blades available.
- Can be driven with our existing VMM/VCM drive units. Special driver not required.
- Available housed or un-housed for OEM applications.
- #103 Mounting Ring available for universal mounting applications.
- Electronic Synchronization System option available.
- Exposure repetition rates from DC to 3 Hz.
- Design, accuracy, and reliability that you have come to know as with all other UNIBLITZ products!

The CS90 is the third release in the new UNIBLITZ® CS series. The small form factor allows a 90 mm aperture to be installed into applications not presently accessible with existing UNIBLITZ VS series shutters. As with the CS45 and CS65, the CS90 has been designed to provide accurate, repeatable exposures for a wide variety of applications. The small form factor allows a 90 mm aperture to be installed into a seven-inch diameter housing. To increase the unit's flexibility, the shutter can be supplied in an un-housed version for OEM applications or in situations inaccessible to most shutters due to spatial limitations.

The device incorporates a dual actuator system. This dual actuator system incorporates the drive circuit for the auxiliary actuator onto the device, allowing the shutter to be controlled with existing UNIBLITZ drive units only. Please note that the 122-BP will not operate the CS90 at this time. (for more information regarding the use of OEM drivers – either UNIBLITZ or of your own design, please contact technical support.) As an option, the shutter can be equipped the electronic synchronization system.

When gating high intensity light sources, the CS90 can be equipped with polished stainless steel reflective blades. This option protects the shutter blades from the light source's damaging effects by reflecting the energy away from the blade surface. Look for future availability of "Z" (AlSiO) and "ZM" (AlMgF₂) coated blades in this device.

To further enhance the flexibility of the CS90; an optional #103 mounting ring is available to allow the shutter to be easily mounted in many non-specific applications. Additional information regarding the #103 mounting ring can be found in the specific data sheet entitled "MICROSCOPE & VIDEO MOUNTING SYSTEMS" or on-line under "products", "Mounting Systems".

¹Voltage level required across actuator coil when being held in the open position.
²VMM dual hold level driver system included in UNIBLITZ VMM shutter controller. Not including device drops.
³Drive system on board for auxiliary actuator. When using a UNIBLITZ drive system (i. e. VMM or VCM series) 7.0VDC is supplied. When operating this device without UNIBLITZ drive equipment, (i.e. using a driver of your own design, etc.) please request and review the CS90 Shutter Electrical Configuration Layout.
 Please note the 122-BP driver should not be used to operate the CS90 at this time. Only VMM and VCM type drivers are recommended to operate the CS90. For more information regarding the use of OEM drivers please contact technical support.
⁴CONTinuous frequency rating specified at shutter's minimum exposure pulse. BURST frequency rating specified for (4) four seconds maximum with (1) one minute minimum between bursts. Frequency measurements are taken in free air, 25°C ambient, actuator coil equipped with heat sink. For additional information on maximum sustained frequencies obtainable, please contact one of our technical representatives.

For note 5 see next page

ELECTRICAL ⁵

	Primary Actuator	Auxiliary Actuator ³
Coil Resistance	12 ohms	12 ohms
Pulse Voltage to Open	+70VDC	+7VDC
Hold Voltage ¹	+7VDC/+5VDC ²	N/A

MECHANICAL

Wgt. Un-Cased	7.96 oz (0.23 kg)
Wgt. Cased	20.04 oz (0.57 kg)
Operating Temp.	0°C to +80°C
Max. Opening Bounce	15%
Max. Closing Bounce	5%
Max. Frequency of Operation (CONT/BURST) ⁴	1 Hz / 3 Hz
Number of Blades	6

TIMING

Typical timing values (msec.) using UNIBLITZ drive equipment and measured with UNIBLITZ shutters equipped with standard TEFLON® coated shutter blades.

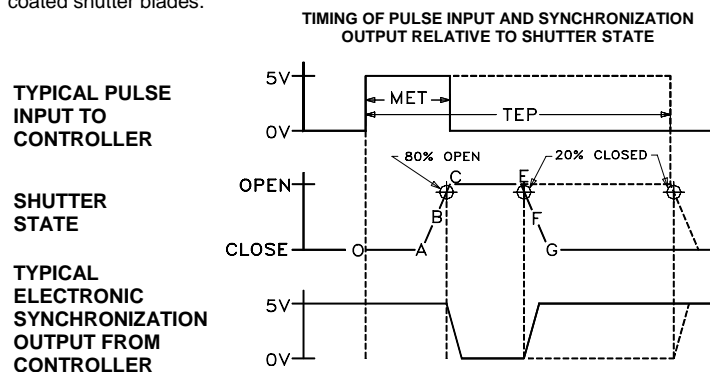

(Timing in msec.)

O-A Delay time on opening after current is applied	20.0
A-C Transfer time on opening	70.0
O-C Total opening time	90.0
B-F Min. equivalent exp. time	100.0
C-E Min. dwell time with min. input pulse	20.0
E-G Transfer time on closing	90.0
A-G Total window time	180.0

MET: Min. exposure time	100.0
TEP: Typical exposure pulse	>100.0

The question regarding enhancement of shutter speed with the application of user supplied lubricants has been repeatedly asked. It is our experience that lubricating the shutter blades will actually slow the shutter down and eventually render the shutter inoperable. UNDER NO CIRCUMSTANCES SHOULD ANY TYPE OF LUBRICANT BE APPLIED TO THE SHUTTER BLADE AREA.

PRODUCT OPTIONS

CS90S	3	T	0	-103
APERTURE SIZE	HOUSING	BLADE FINISH	SOLID STATE SYNCHRONIZATION	MOUNTING OPTIONS
CS90S - 90mm	1 - UNCASED 3- #3 CASE	T - TEFLON COATED S - POLISHED STAINLESS	0 - OMIT SYNC. 1 - SOLID STATE SYNC.	-103 MOUNTING RING

*input side only. Teflon® coating is on opposite side. Intended to protect the shutter blade surface, light source must be input to the reflective side only.

CS90 SHUTTER PRELIMINARY SPECIFICATIONS

Vincent Associates 803 Linden Avenue, Rochester, NY 14625
 web www.uniblitz.com e-mail vincentassociates@uniblitz.com toll-free 800.828.6972



UN-HOUSED STYLE

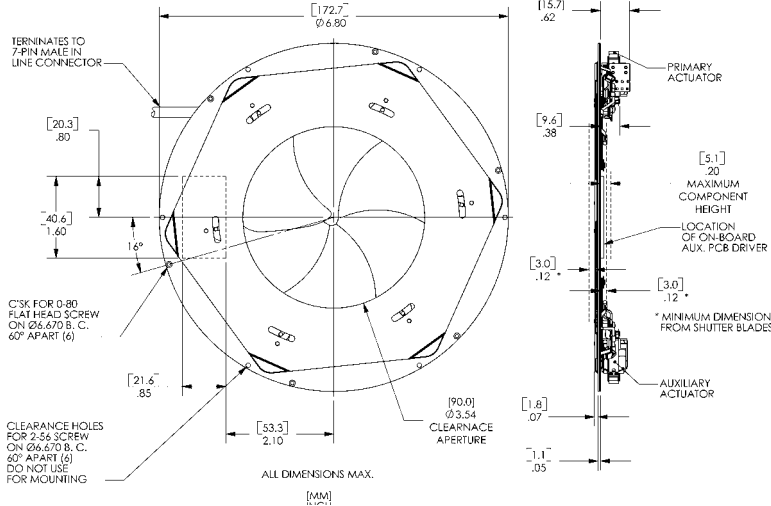

The CS90 un-housed style is the basic configuration of this device and is best suited for OEM applications. Mounting can be accomplished through six 0-80 (flat head required) clearance holes located around the unit's perimeter on a 6.670 inch diameter bolt circle. These holes, as indicated, are 60 degrees apart. Unless otherwise specified, this standard unit is terminated to a 7-pin male connector through a 7-wire six-inch cable assembly. (The six 2-56 holes are not recommended for mounting due to the potential for interference with the shutter's six blades.)

HOUSED STYLE

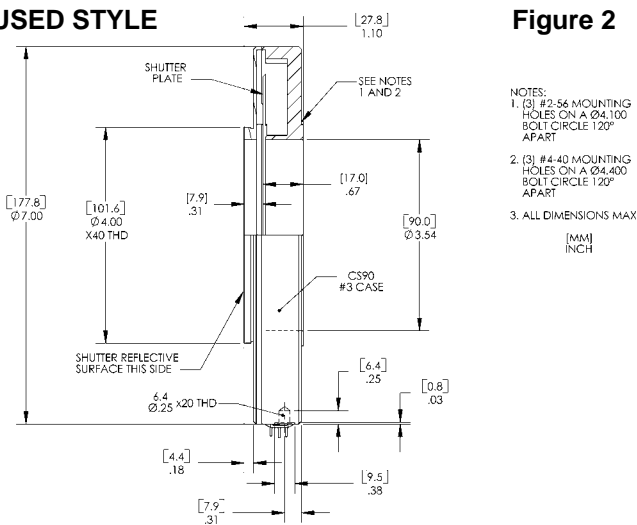

The CS90 #3 housing style allows a number of mounting configurations. A 1/4-20 threaded hole is provided for post mounting. The 4.00inch x 40TPI external thread located on the rear side, and the specific mounting holes located on the front side (see Figure #2 and Figure #3) can be interfaced directly into your application or fitted with a variety of user specific mounting options. For the CS90, the #103 Mounting Ring is a mounting option available that simplifies mounting the housed style onto a flat surface. Additional information regarding the #103 mounting ring can be found in the specific data sheet entitled "MICROSCOPE & VIDEO MOUNTING SYSTEMS" or on-line under "products", "Mounting Systems". The unit terminates with a 7-pin male connector as illustrated.

HOUSING/CONNECTOR LAYOUT

Figure 3

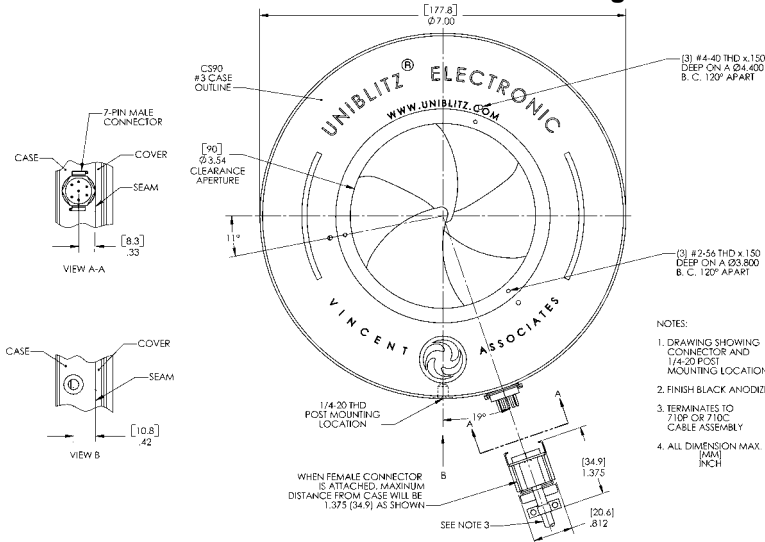

This drawing illustrates 7-pin connector and 1/4-20 threaded hole layout for the CS90 series #3 housed style.

When operating this device without UNIBLITZ drive equipment, (i.e. using a driver of your own design, etc.) please review the CS90 Shutter Electrical Configuration Layout. This can be requested from our web site and/or downloaded from our web site's resources page. Improper connections made to this device can cause irreparable damage to the unit's integrated auxiliary actuator driver board. Due to the nature of the unit's design, please exercise anti-static protocol when handling this device.

DUE TO THE ACTUATOR CONFIGURATION AND THE ON BOARD AUX DRIVER, DO NOT USE THE 122-BP CONTROLLER TO OPERATE THE CS90. PLEASE CONTACT OUR TECHNICAL SUPPORT STAFF WHEN USING ANY OEM DRIVER DESIGN.