



# Manual EXO series

**exo174\*CL, exo249\*CL, exo250\*CL, exo252\*CL, exo267\*CL,  
exo304\*CL, exo4000\*CL, exo5000\*CL**

## Company Information

SVS-VISTEK GMBH

Mühlbachstr. 20  
82229 Seefeld  
Germany

Tel.: +49 (0) 81 52 9985-0  
Fax: +49 (0) 81 52 9985-79  
Mail: [info@svs-vistek.com](mailto:info@svs-vistek.com)  
Web: <http://www.svs-vistek.com>

This Operation Manual is based on the following standards:

DIN EN 62079  
DIN EN ISO 12100  
ISO Guide 37  
DIN ISO 3864-2  
DIN ISO 3864-4

This Operation Manual contains important instructions for safe and efficient handling of SVCam Cameras (hereinafter referred to as „camera“). This Operating Manual is part of the camera and must be kept accessible in the immediate vicinity of the camera for any person working on or with this camera.

Read carefully and make sure you understand this Operation Manual prior to starting any work with this camera. The basic prerequisite for safe work is compliant with all specified safety and handling instructions.

Accident prevention guidelines and general safety regulations should be applied.

Illustrations in this Operation Manual are provided for basic understanding and can vary from the actual model of this camera. No claims can be derived from the illustrations in this Operation Manual.

The camera in your possession has been produced with great care and has been thoroughly tested. Nonetheless, should you have reasons for complaint, then please contact your local SVS-VISTEK distributor. You will find a list of distributors in your area under: <http://www.svs-vistek.com/company/distributors/distributors.php>

## Copyright Protection Statement

(as per DIN ISO 16016:2002-5)

Forwarding and duplicating of this document, as well as using or revealing its contents are prohibited without written approval. All rights reserved with regard to patent claims or submission of design or utility patent.

# Contents

1	Safety Messages .....	5
2	Legal Information.....	6
3	The EXO.....	7
3.1	Building blocks simplify design-in.....	7
3.1.1	Exclusive body architecture .....	7
3.1.2	Form follows requirements.....	7
3.2	4IO adds Light and Functionality.....	8
3.2.1	Camera Link Features .....	8
4	Getting Started .....	9
4.1	Contents of Camera Set.....	9
4.2	Power supply.....	9
4.3	Camera Link Flashing LED Codes.....	9
4.4	Software.....	10
4.4.1	Installation of ConvCam5.....	10
4.4.2	Connecting the camera .....	12
4.4.3	ConvCam5 .....	12
4.4.4	Viewer Software .....	12
4.5	Driver Circuit Schematics .....	15
5	Connectors .....	16
5.1	Camera Link™ .....	16
5.1.1	Connectors Camera Link™.....	16
5.1.2	Pinout Diagram .....	18
5.1.3	Camera Link timing.....	19
5.2	Input / output connectors.....	20
6	Dimensions .....	22
6.1	exo174*CL, exo249*CL.....	23
6.2	exo250*CL, exo252*CL.....	27
6.3	exo267*CL, exo304*CL.....	30
6.4	exo4000*CL .....	33
6.5	exo5000*CL.....	37
6.6	C & CS Mount .....	41
7	Feature-Set .....	42
7.1	Basic Understanding.....	42
7.1.1	Basic Understanding of CMOS Technology.....	42
7.1.2	Global Shutter / Progressive Scan .....	45
7.1.3	Frames per Second .....	46

7.1.4	Acquisition and Processing Time .....	46
7.1.5	Exposure .....	47
7.1.6	Auto Luminance.....	47
7.1.7	Bit-Depth .....	48
7.1.8	Color.....	50
7.1.9	<b>Resolution – active &amp; effective .....</b>	<b>51</b>
7.1.10	Gain.....	52
7.1.11	Image Flip.....	53
<b>7.2</b>	<b>Camera Features.....</b>	<b>54</b>
7.2.1	System Clock Frequency .....	54
7.2.2	Temperature Sensor .....	54
7.2.3	Basic Capture Modes .....	55
7.2.4	LookUp Table.....	58
7.2.5	ROI / AOI.....	60
<b>7.3</b>	<b>I/O Features .....</b>	<b>60</b>
7.3.1	Assigning I/O Lines – IOMUX .....	60
7.3.2	Strobe Control.....	67
7.3.3	Sequencer.....	74
7.3.4	PWM .....	76
7.3.5	Optical Input.....	77
7.3.6	PLC/Logical Operation on Inputs .....	79
7.3.7	Serial data interfaces.....	80
7.3.8	Trigger-Edge Sensitivity.....	83
7.3.9	Debouncing Trigger Signals .....	83
7.3.10	Prescale .....	85
7.3.11	IR Cut Filter .....	86
<b>8</b>	<b>Specifications .....</b>	<b>88</b>
1.1	EXO174*CL.....	89
8.1	EXO249*CL.....	92
1.1	EXO250*CL.....	95
8.1	EXO267*CL.....	98
8.1	EXO304*CL.....	101
8.1	EXO4000*CL.....	104
8.1	EXO5000*CL.....	107
<b>9</b>	<b>Terms of warranty .....</b>	<b>110</b>
<b>10</b>	<b>Troubleshooting.....</b>	<b>112</b>
10.1	FAQ .....	112
10.2	Support Request Form / Check List .....	113
<b>11</b>	<b>IP protection classes .....</b>	<b>115</b>
<b>12</b>	<b>Glossary of Terms .....</b>	<b>117</b>
<b>13</b>	<b>Index of figures .....</b>	<b>120</b>
<b>14</b>	<b>Index.....</b>	<b>122</b>

# 1 Safety Messages

The classification of hazards is made pursuant to ISO 3864-2 and ANSI Y535.6 with the help of key words.

This Operating Manual uses the following Safety Messages:









Risk of death or serious injury		<b>DANGER!</b> Danger indicates a hazard with a high level of risk which, if not avoided will result in death or serious injury.
		<b>WARNING!</b> Warning indicates a hazard with a medium level of risk which, if not avoided will result in death or serious injury.
		<b>CAUTION!</b> Caution indicates a hazard with a low level of risk which, if not avoided will result in death or serious injury.
Risk of damage		<b>PROHIBITION!</b> A black graphical symbol inside a red circular band with a red diagonal bar defines a safety sign that indicates that an action shall not be taken or shall be stopped.
		<b>CAUTION!</b> A black graphical symbol inside a yellow triangle defines a safety sign that indicates a hazard.
		<b>MANDATORY ACTION!</b> A white graphical symbol inside a blue circle defines a safety sign that indicates that an action shall be taken to avoid a hazard.
Cross-reference 		<b>NOTICE</b> Provides references and tips

FIGURE 1: TABLE OF SAFETY MESSAGES

---

## 2 Legal Information

Information given within the manual accurate as to: February 22, 2017, errors and omissions excepted.

These products are designed for industrial applications only. Cameras from SVS-Vistek are not designed for life support systems where malfunction of the products might result in any risk of personal harm or injury. Customers, integrators and end users of SVS-Vistek products might sell these products and agree to do so at their own risk, as SVS-Vistek will not take any liability for any damage from improper use or sale.



### Europe

This camera is CE tested, rules of EN 55022:2010+AC2011 and EN61000-6-2:2005 apply.

All SVS-VISTEK cameras comply with the recommendation of the European Union concerning RoHS Rules

### USA and Canada

This device complies with part 15 of the FCC Rules. Operation is subject to the following conditions: (1) This device may not cause harmful interference, and (2) this device must accept any interference received, including interference that may cause undesired operation.

Note: This equipment has been tested and found to comply with the limits for a Class A digital device, pursuant to part 15 of the FCC Rules. These limits are designed to provide reasonable protection against harmful interference when the equipment is operated in a commercial environment. This equipment generates, uses, and can radiate radio frequency energy and, if not installed and used in accordance with the instruction manual, may cause harmful interference to radio communications. Operation of this equipment in a residential area is likely to cause harmful interference in which case the user will be required to correct the interference at its own expense.

It is necessary to use a shielded power supply cable. You can then use the "shield contact" on the connector which has GND contact to the camera housing. This is essential for any use. If not done and camera is destroyed due to Radio Magnetic Interference (RMI) **WARRANTY is void!**

- **Power:** US/UK and European line adapter can be delivered. Otherwise use filtered and stabilized DC power supply.
- Shock & Vibration Resistance is tested: For detailed Specifications refer to Specification.

---

## 3 The EXO

The EXO series features a perfect match with its sophisticated, rugged unibody housing and rich camera feature set, combined with industry standard interfaces such as GigE Vision, Camera Link and USB3 Vision. A smart solution for virtually any application, allowing smooth and effortless up- or downscaling of machine vision applications. The EXO is easy to integrate and comes with a full package of useful hardware features.

The EXO series features a perfect match with its sophisticated, rugged unibody housing and rich camera feature set, combined with industry standard interfaces such as GigE Vision, Camera Link and USB3 Vision. A smart solution for virtually any application, allowing smooth and effortless up- or downscaling of machine vision applications. The EXO is easy to integrate and comes with a full package of useful hardware features.

### 3.1 Building blocks simplifies design-in

#### 3.1.1 Exclusive body architecture

The EXO-Series comes in a new 50 x 50 mm aluminum body. The elaborate, high precision machined unibody housing ensures perfect temperature distribution even for the most demanding sensors. The electric circuitry of the EXO is optimized for low power dissipation, helped by the excellent temperature performance of the housing. The EXO features the latest global shutter CMOS and CCD sensors from SONY, CMOSIS and ON Semi.

#### 3.1.2 Form follows requirements

A uniform form factor and identical standard interface connectors with identical pinout facilitate interchangeability, allowing system integrators to adapt applications with varying conditions and requirements very quickly with minimum design effort. The massive lens mount is designed to keep any kind of lens in its proper position.

### 3.2 4IO adds Light and Functionality

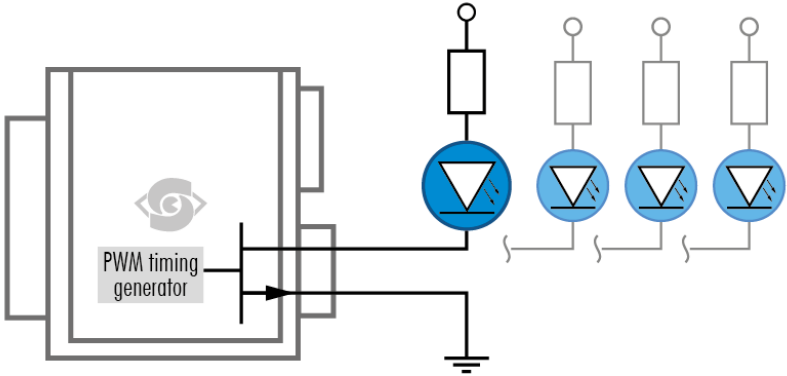

Figure 2: Illustration of 4IO concept of switching LEDs

Your SVS-Vistek camera is

equipped with the innovative 4IO-interface allowing full light control, replacing external strobe controllers. Each of the 4 outputs can be individually configured and managed using pulse-width modulation. With its high current output, the camera is able to drive LED lights directly without external light controller.

If you attach any light to the camera, make sure the power supply has enough power not to fail when the camera is putting light ON.

The integrated sequencer allows multiple exposures with settings to be programmed, creating new and cost effective options. Logical functions like AND / OR are supported.

- > 4 x open drain high power OUT
- > 4 x high voltage IN – TTL up to 25 Volts
- > Power MOSFET transistors
- > PWM strobe control
- > Sequencer for various configurations
- > PLC functionality with AND, OR and timers
- > Safe Trigger (debouncer, prescaler, high low trigger)

### 3.3 Camera Link Features

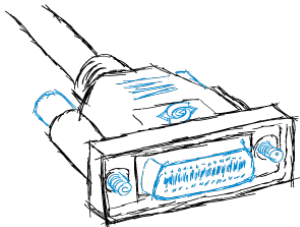

Camera Link is the most direct serial connection to the sensor and preferred by integrators with high demands on bandwidth and integration in existing systems.

Note: The EXO\*CL cameras are supporting 1x3\_1y tap configuration. If your framegrabber is supporting this as well, you might get framerates up to 50% higher than shown in the datasheet.



---

## 4 Getting Started

### 4.1 Contents of Camera Set

- > Camera
- > Power supply (if ordered/option)
- > Quick guide
- > User Manual
- > Software installer – ConvCam
- > Euresys camera file (optional)

### 4.2 Power supply

Connect the power supply.



**CAUTION!** – This camera does not support hotplugging

1. First, connect the data cable.
2. Then connect power supply.

When using your own power supply (e.g. 10 -25 V DC) see also Hirose 12-pin for a detailed pin layout of the power connector. For power input specifications refer to specifications.

### 4.3 Camera Link Flashing LED Codes

On power up, the camera will indicate its current status with a flashing LED on its back. The LED will change color and rhythm.

The meaning of the blinking codes translates as follows:



Flashing	Description
 Yellow quickly ( $\approx 8$ Hz )	booting
 Yellow permanent	ready
 Red slow ( $\approx 1$ Hz )	error

Table 1 table of flashing LED codes

## 4.4 Software

Further information, documentations, release notes, latest software and application manuals can be downloaded in the download area on: <https://www.svs-vistek.com/en/login/svs-loginarea-login.php>

Depending on the type of camera you bought, several software packages apply.

### 4.4.1 Installation of ConvCam5

**CAUTION!**  
Make sure you have the latest ConvCam5. At time of printing, this is version 1.0.13

Your SVCam combined software installer including:

- > SVConvCam  
(a controller app for SVCam Camera Link cameras)
- > TL\_Driver  
(GenlCam drivers and transport layer DDLs)

- 1<sup>st</sup> Expand ZIP
  - > Extract the zip archive to your local hard drive.
- 2<sup>st</sup> Install
  - > Run the executable file.1\*
  - > Click “Install”
  - > Click “Next”

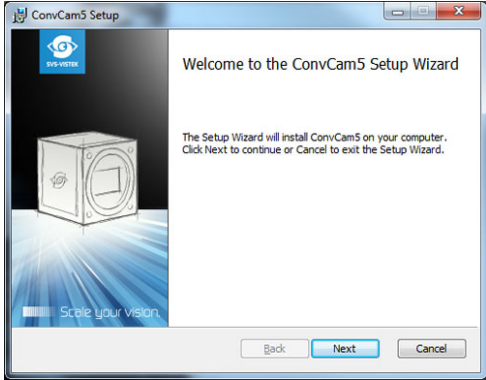
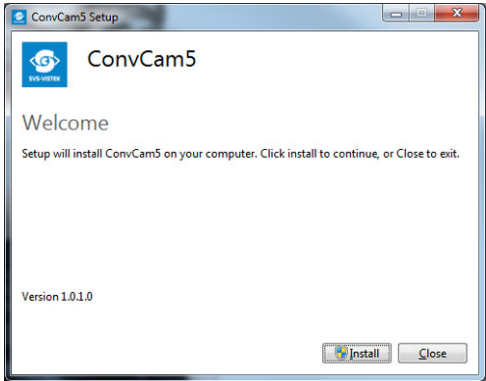

> Read and accept terms of License Agreement

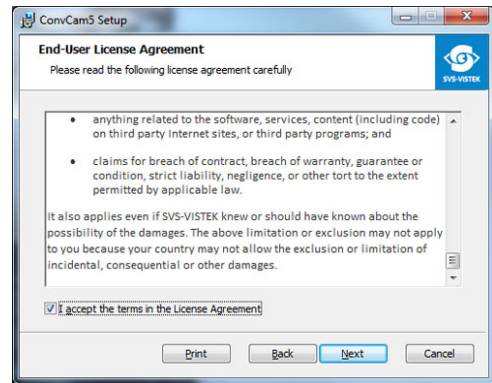

> Choose Options 2\* and Location to install

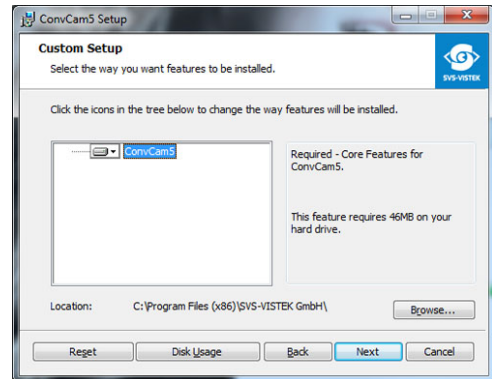

> Click "Finish"

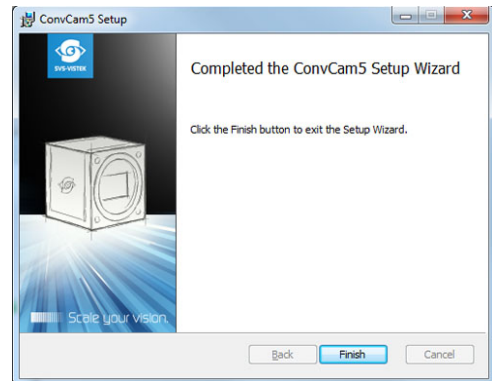

- 1 x64 for 64 bit operating systems
- \* x86 for 32 bit operating systems
- 2 It is recommended to install all applications included to the installation package.
- \*

#### 4.4.2 Connecting the camera

1. Connect the camera with a Camera Link cable to your frame grabber
2. Connect power source to the camera

Run the camera controller tool: ConvCam

Select your frame grabber.

#### INFORMATION NEEDED BY YOUR FRAMEGRABBER:

- > Tap configuration
- > Trigger mode
- > Pixel width and height

#### 4.4.3 ConvCam5

Set values as needed

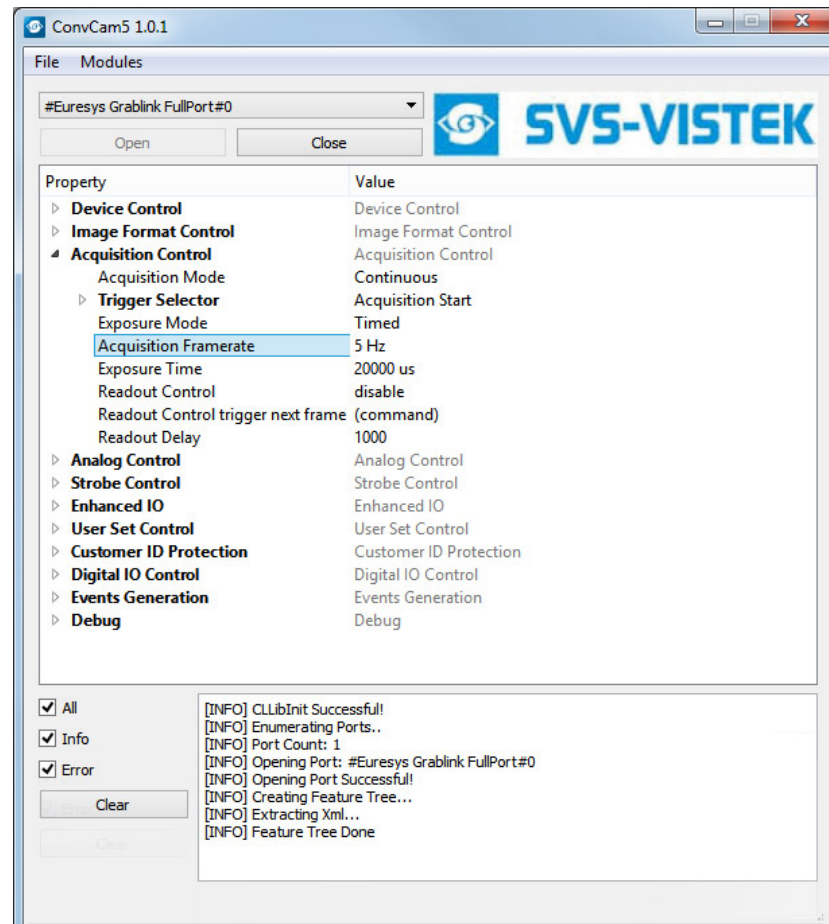

#### 4.4.4 Viewer Software

The final image will be shown or processed by your own valued software package. After camera configuration an image will be directed to the software connected to your frame grabber.

E.g. Multicam by Euresys

While using a Euresys frame grabber the first impression imaging tool "Multicam" is available to the hardware.

Run Multicam Studio.

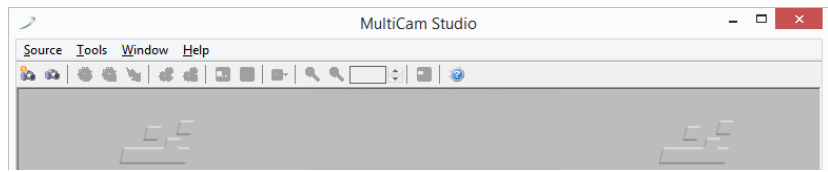

- > Add a new "source" to the application
- > Choose "Camera Link industrial Camera..."
- > Click "next"
- > In the list of camera vendors choose "SVS-VISTEK" and the camera you want to view.
- > Select frame grabber and connector

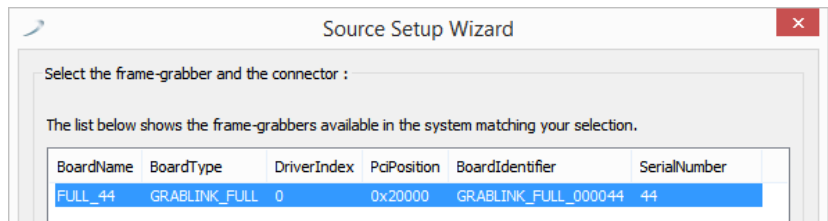

- > For "Topology" values refer to the Euresys documentation. At first: stay with "Mono" for topology.

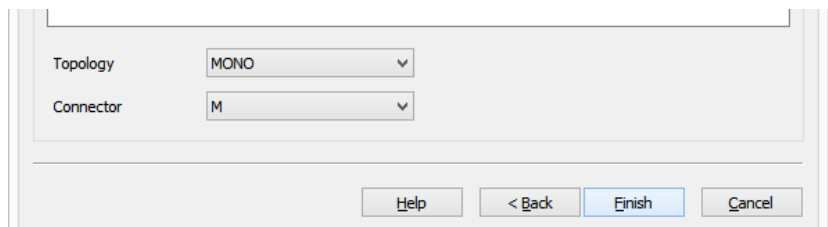

- > Choose your connector configuration
- > click "Finish"

Now an image should appear, according to your setup configurations made with ConvCam

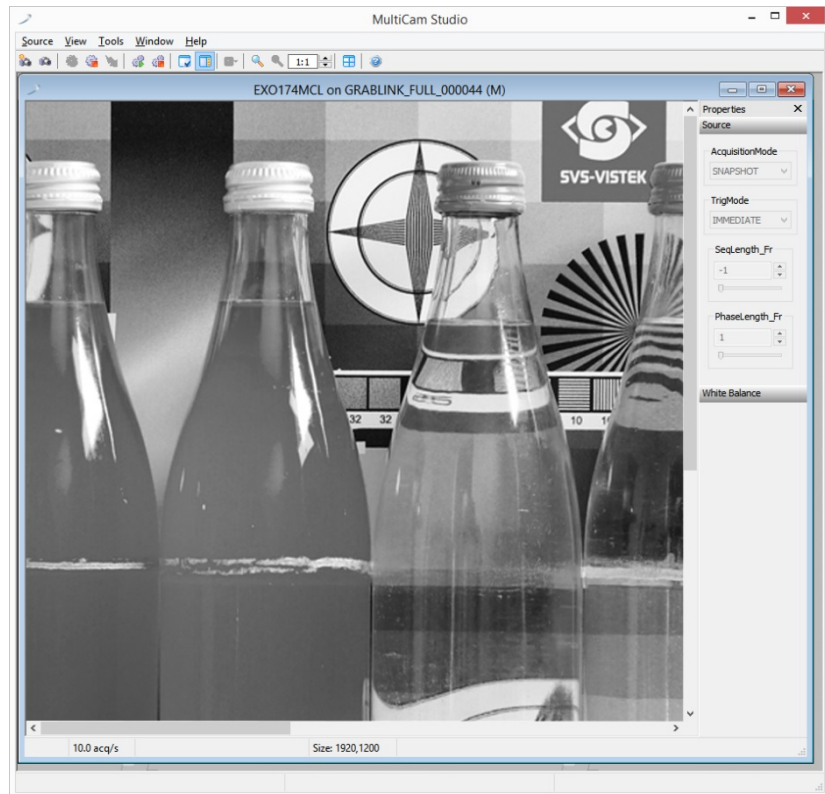

For further information on Euresys Multicam Studio refer to the documentation from Euresys.

## 4.5 Driver Circuit Schematics

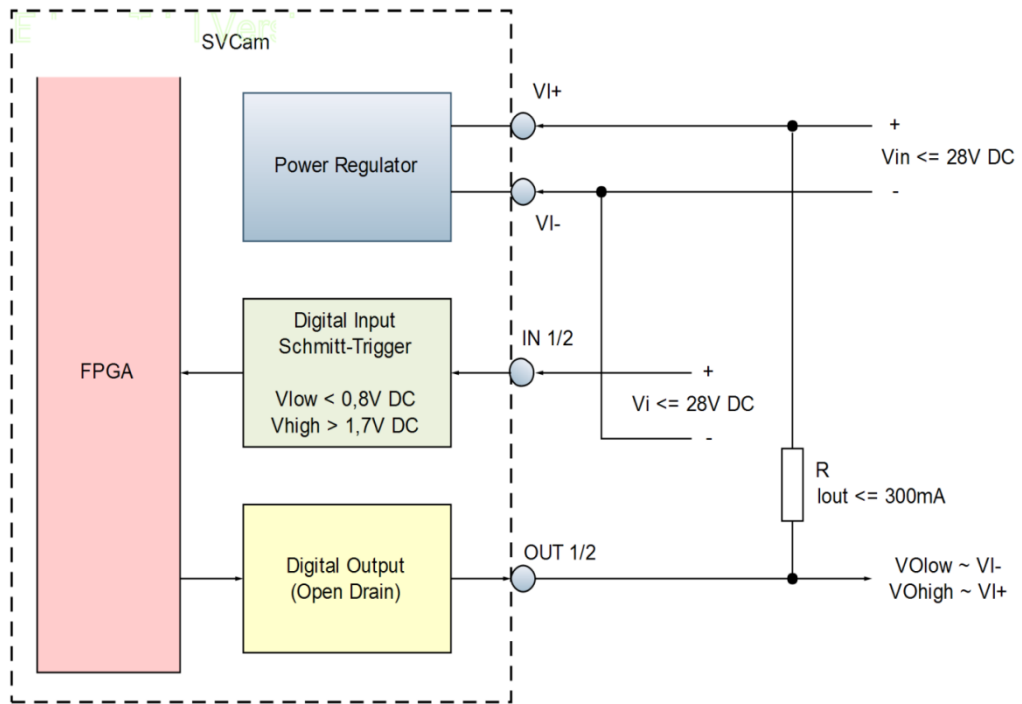
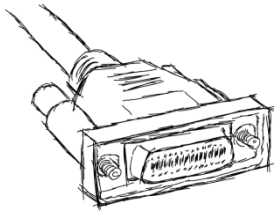

Figure 3: basic Illustration of driver circuit

---

## 5 Connectors



### 5.1 Camera Link™

To use Camera Link a frame grabber is needed.  
Frame grabbers can be purchased at [SVS-VISTEK](#), too.

#### 5.1.1 Connectors Camera Link™

---

Specification	
Type	26 Pin connector MDR female
Mating Connector	3M
Part-Nr. connector	10126-6000EL
Part-Nr. hood	10326-A200-00
Operating Mode	Camera Link™ with RS 232 communication





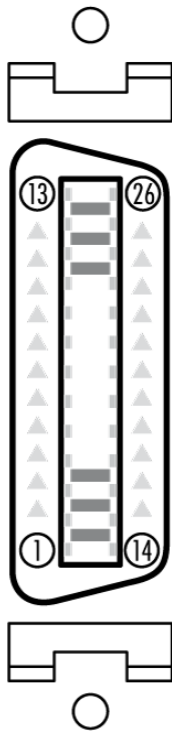

Pinout Pin	Signal Name	Direction	Signal Description
- 1 -	GND / 12 V	-	Shield 1 / 12 V power*
- 2 -	X0-	Camera to FG	Data
- 3 -	X1-	Camera to FG	Data
- 4 -	X2-	Camera to FG	Data
- 5 -	Xclk-	Camera to FG	Transmitter Clock / PVAL
- 6 -	X3-	Camera to FG	Data
- 7 -	SerTC+	FG to Camera	Camera Control (RS232)
- 8 -	SerTFG-	Camera to FG	Camera Control (RS232)
- 9 -	CC1-	FG to Camera	ExSync
- 10 -	CC2+	FG to Camera	Prin (not used)
- 11 -	CC3-	FG to Camera	External Camera Clock
- 12 -	CC4+	FG to Camera	nc
- 13 -	GND	-	Shield 3 / power return*
- 14 -	GND	-	Shield 2 / power return*
- 15 -	X0+	Camera to FG	Data
- 16 -	X1+	Camera to FG	Data
- 17 -	X2+	Camera to FG	Data
- 18 -	Xclk+	Camera to FG	Transmitter Clock
- 19 -	X3+	Camera to FG	Data
- 20 -	SerTC-	FG to Camera	Camera Control (RS232)
- 21 -	SerTFG+	Camera to FG	Camera Control (RS232)
- 22 -	CC1+	FG to Camera	Exsync
- 23 -	CC2-	FG to Camera	Prin (not used)
- 24 -	CC3+	FG to Camera	External Camera Clock
- 25 -	CC4 -	FG to Camera	nc
- 26 -	GND / 12 V	-	Shield 4 / 12 V power *

Figure 4: Table of Camera Link pin-out / \*PoCL

### 5.1.2 Pinout Diagram

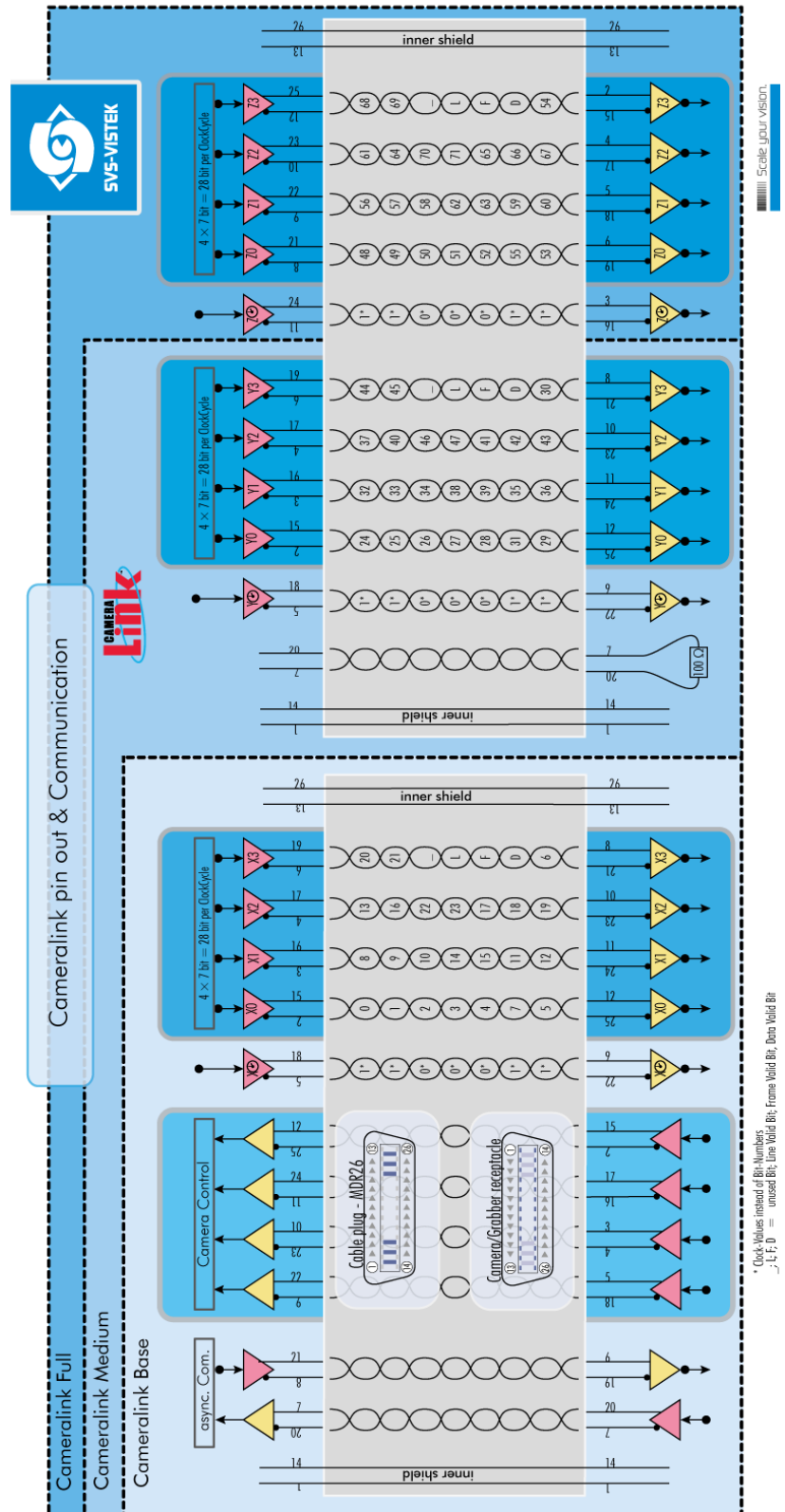

Figure 5: Illustration of Camera Link pin-out

### 5.1.3 Camera Link timing

It might be interesting to know when “valid data” can be expected exactly.

$px_h$  = pixel horizontal [count]

$px_v$  = pixel vertical [count]

#### LVAL – $t_{Lvd}$

Every line has periods with no valid data. The Duration of None Valid Data between two lines ( $t_{nvd}$ ) is three time the Camera Link clock (clk). Delay before every first line is 2 times clk.

$$t_{Lvd} = \frac{px_h}{CL\_geometry\_X} \times \frac{1}{CL\_clock}$$

CL\_clock = 85 MHz

#### FVAL – $t_{Fvd}$

Frames are not sent permanently. Between two frames will be a gap – even at highest frame rates. Minimum duration between two valid frame signals is the duration of one line.

$$t_{Fvd} = 2 \times \frac{1}{CL\_clock} + (t_{Lvd} + t_{nvd}) \times \frac{px_v}{CL\_geometry\_Y}$$

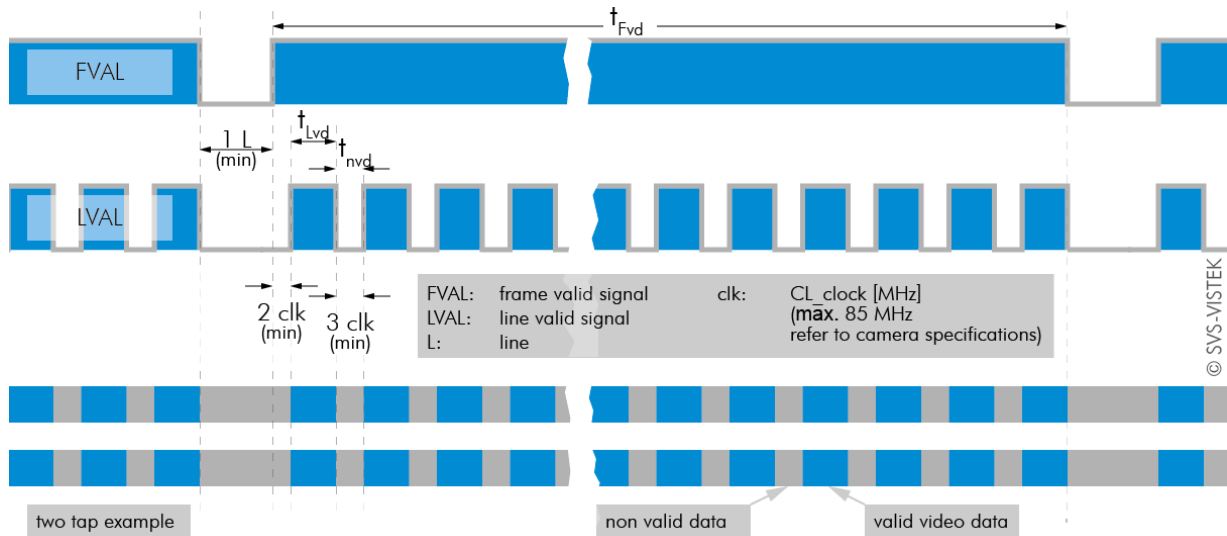

Figure 6: overview of FVAL and LVAL signal timing on Camera Link

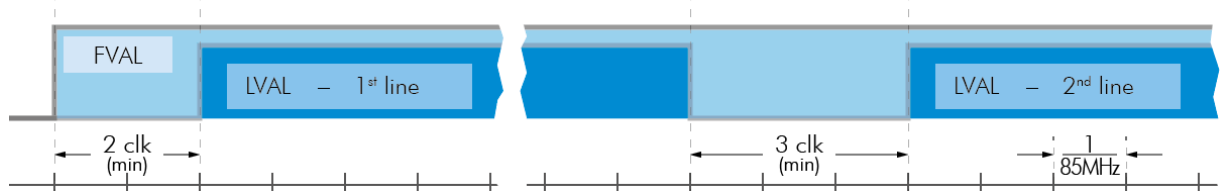

Figure 7: more detailed view of LVAL signal timing on Camera Link

Example calculation		on exo174*CL	
>	$t_{Lvd} = \frac{(1920 / 2)}{\text{px in line / sent at once}} \times \frac{(1/85\text{MHz})}{\text{CL\_clock}}$ $= \frac{960}{1} \times (1/85e^6) \text{ s} \approx 11,29 \mu\text{s}$		
>	$t_{nvd} = \frac{3 \times (1/85\text{MHz})}{\text{time between two valid line data packages}} = (3/85e^6) \text{ s} \approx 35,3 \text{ ns}$		
>	$t_{Fvd} = \frac{2 \times (1/85\text{MHz})}{\text{delay before first line}} + ( t_{Lvd} + t_{nvd} ) \times \frac{1200}{\text{lines [count]}}$ $= \frac{(2/85e^6) \text{ s}}{1} + ( 11,29 \mu\text{s} + 35,3 \text{ ns} ) \times 1200$ $= 23,5 \text{ ns} + ( 11,29 \mu\text{s} + 35,3 \text{ ns} ) \times 1200$ $= \frac{(2 + (960 + 3) \times 1200) \text{ s}}{85e^6} \approx 13,6 \text{ ms}$		

Camera Link architecture exo174\*CL: 1X2\_1Y count = 2  
 pixelh = 1920 pixelv = 1200 CL\_clock = 85 MHz

Figure 8: example calculation of Camera Link timing on a exo174\*CL

## 5.2 Input / output connectors

For further information using the **breakout box** and simplifying I/O connection refer to **SVCam Sensor Actor** manual (with Murr and Phoenix breakout boxes). To be found separate within



the USP manuals.

---

### Hirose™ 12Pin

---

For detailed information about switching lights from inside the camera, refer to strobe control.

---

#### Specification

Type	HR10A-10R-12S
Mating Connector	HR10A-10R-12P

---

### Hirose 12 Pin

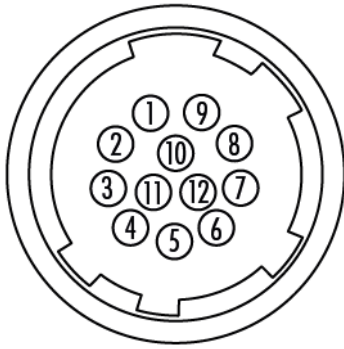

1	VIN –	(GND)
2	VIN +	(10V to 25V DC)
3	IN4	(RXD RS232)
4	OUT4	(TXD RS232)
5	IN1	(0-24V)
6	IN2	(0-24V)
7	OUT1	(open drain)
8	OUT2	(open drain)
9	IN3 +	(opto In +)
10	IN3 –	(opto In –)
11	OUT3	(open drain)
12	OUT0	(open drain)

Figure 9: Illustration of Hirose 12 Pin & pin-out (HR10A-10R-12PB)

---

## 6 Dimensions

All length units in mm. CAD step files available on DVD or [SVS-VISTEK.com](http://SVS-VISTEK.com)

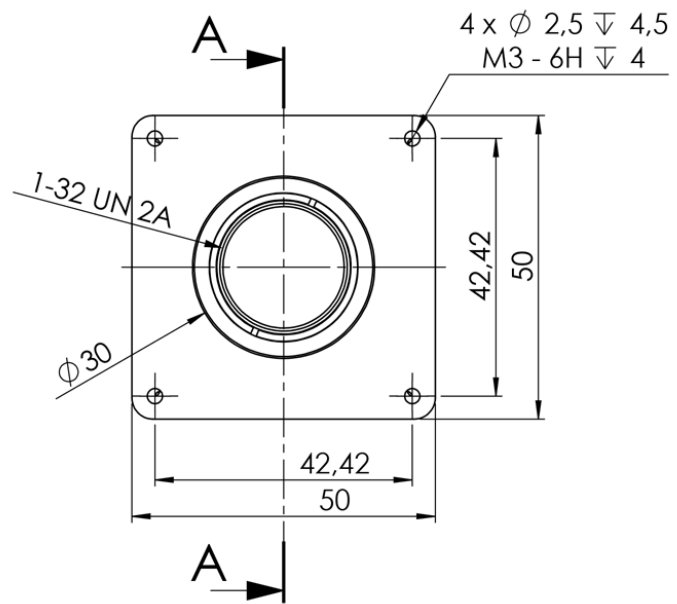
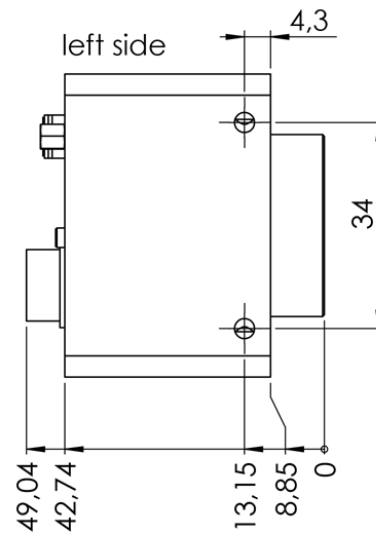
**6.1 exo174\*CL, exo249\*CL****front****side Left**

Side Right

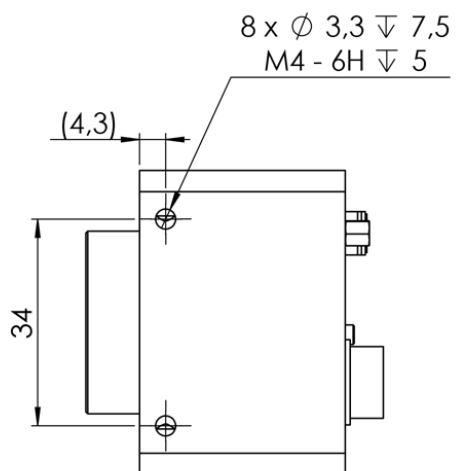

Top

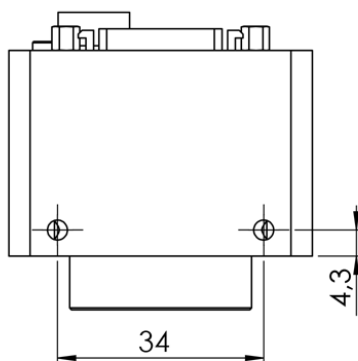



**Bottom**

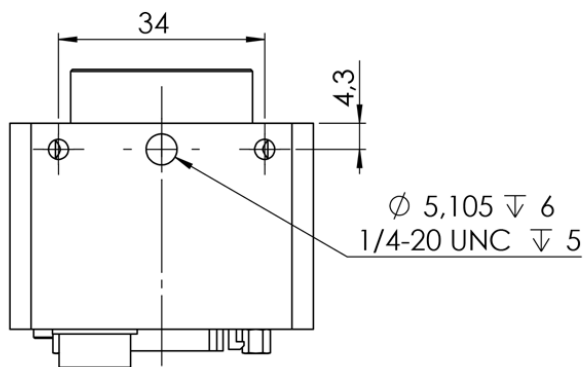

**Back**

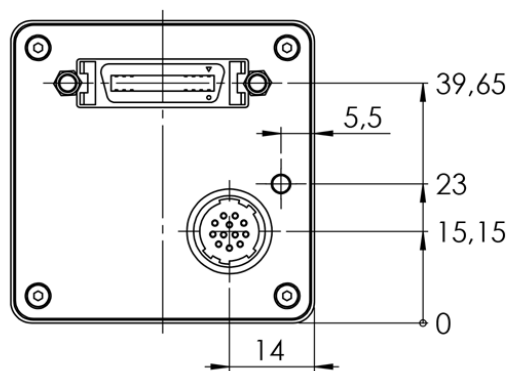

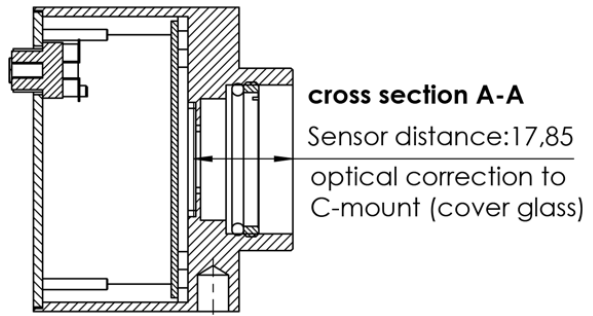
**Cross Section**

## 6.2 exo250\*CL, exo252\*CL

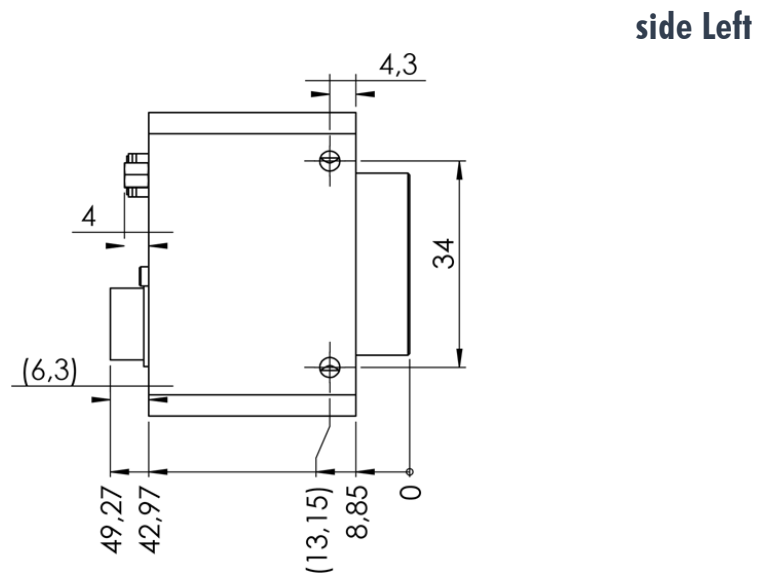
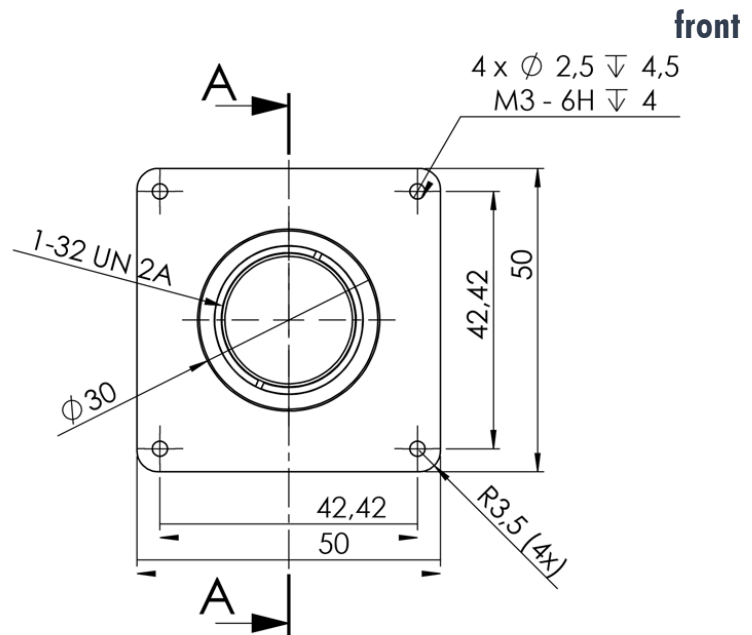

Side Right

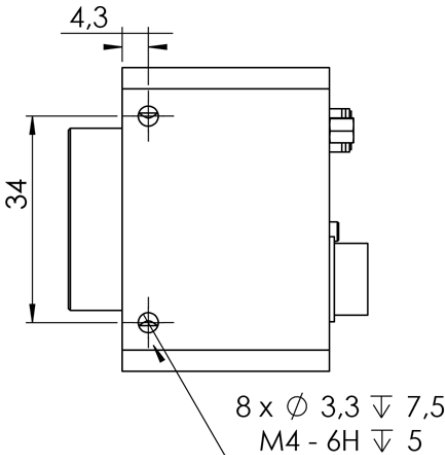

Top

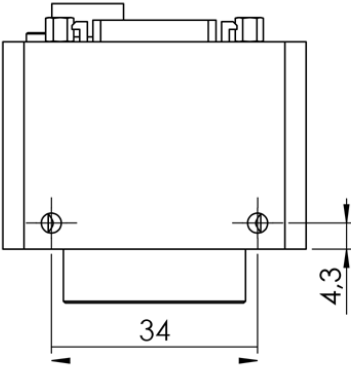

**Bottom**

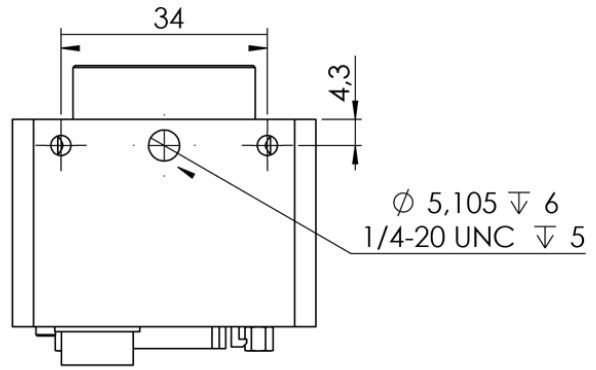

**Back**

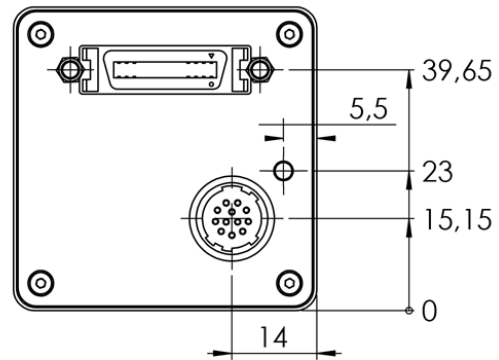

**Cross Section**

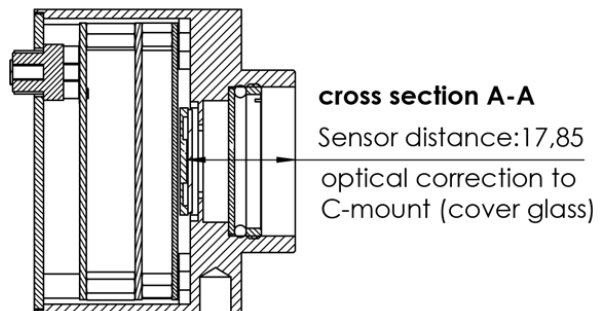

## 6.3 exo267\*CL, exo304\*CL

1"-32 UN 2A

front view

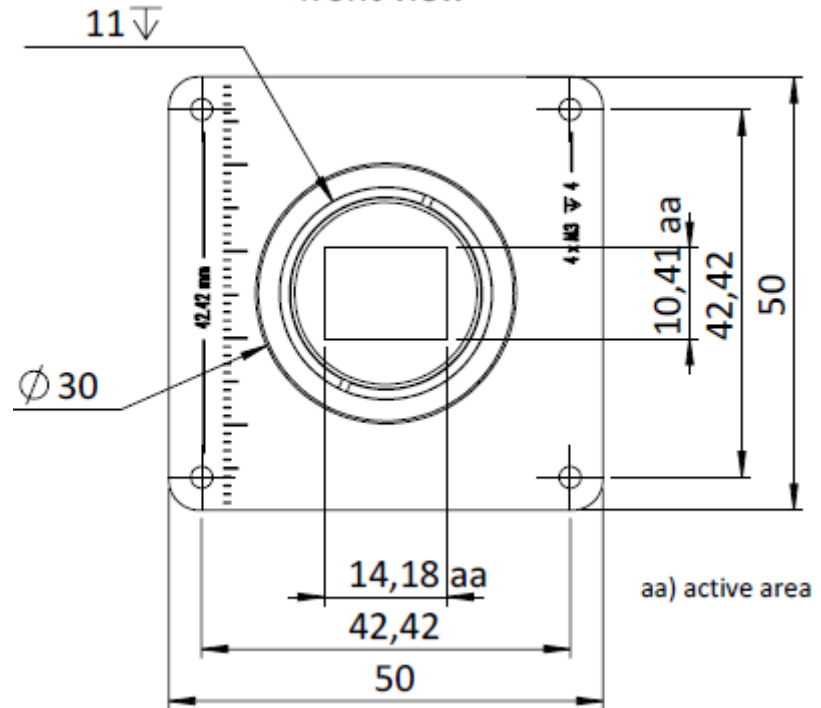

back view

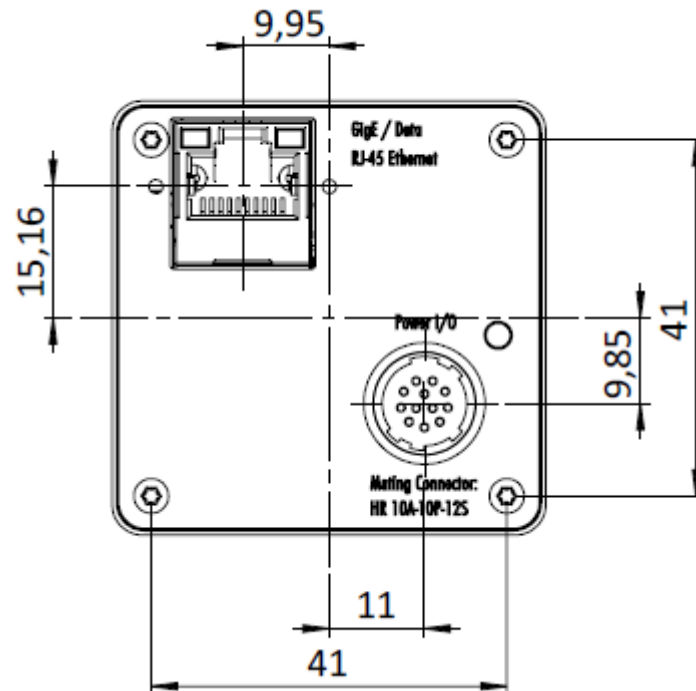

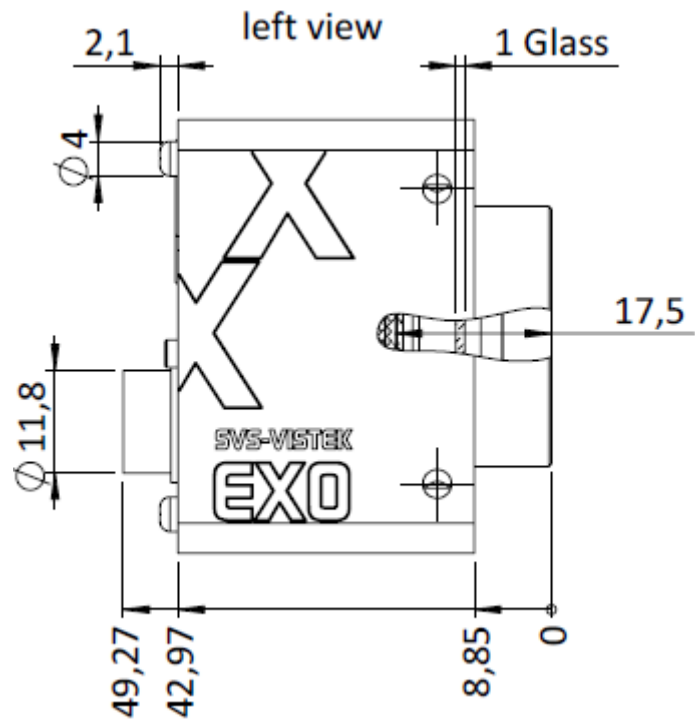

right view

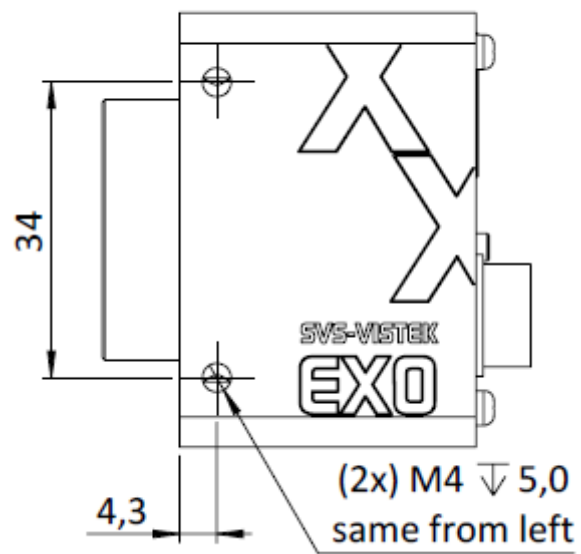

bottom view

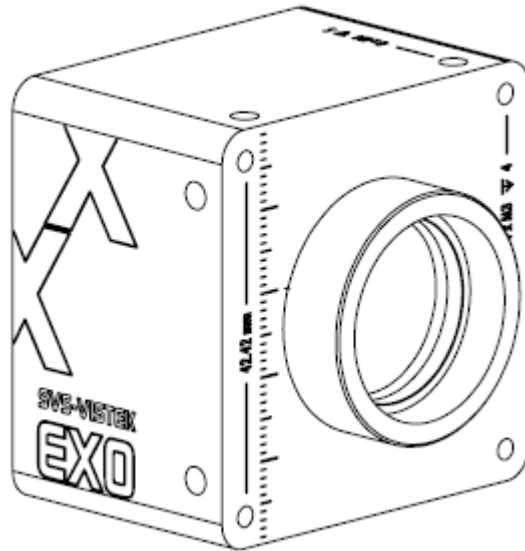
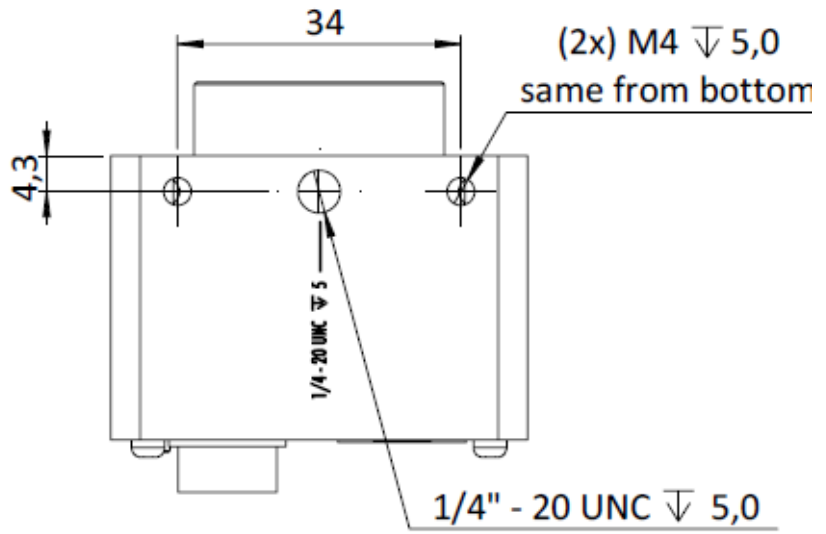

top view

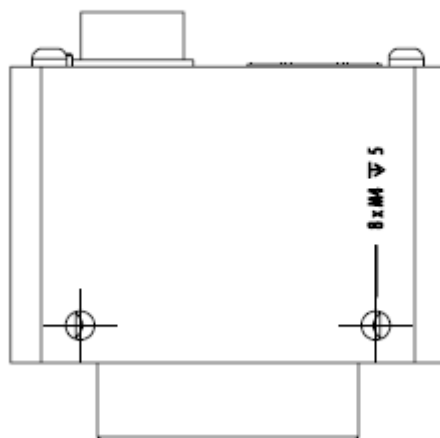

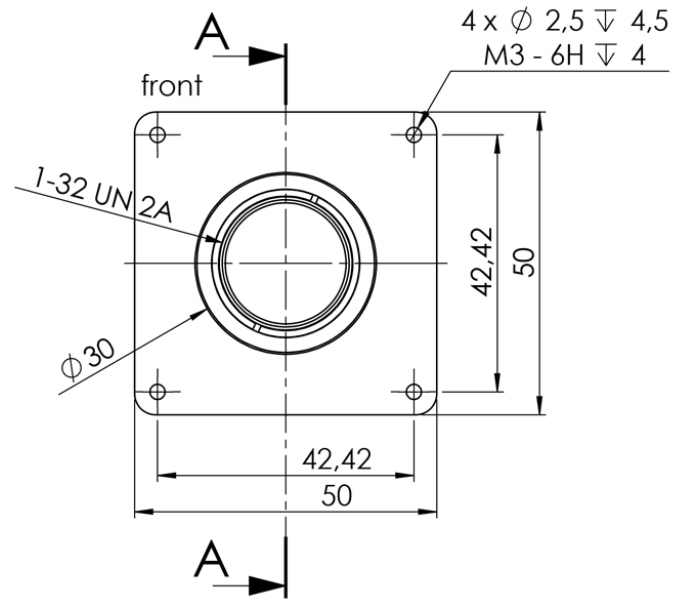
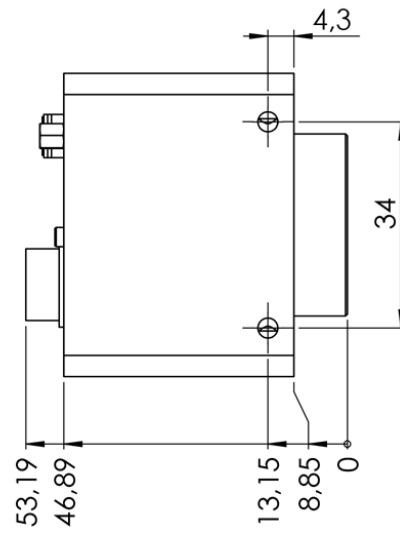

**6.4 exo4000\*CL****front****side Left**

Side Right

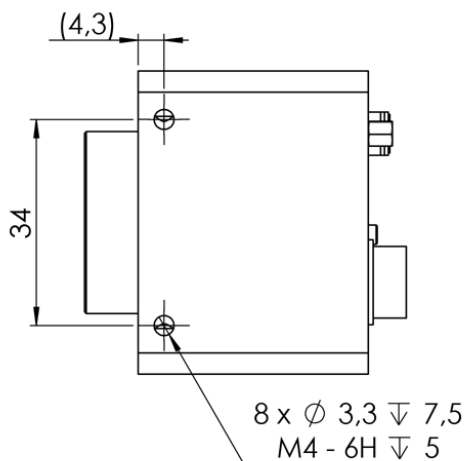

Top

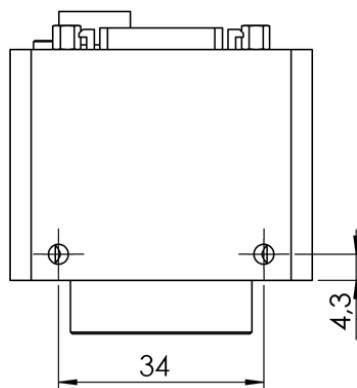

**Bottom**

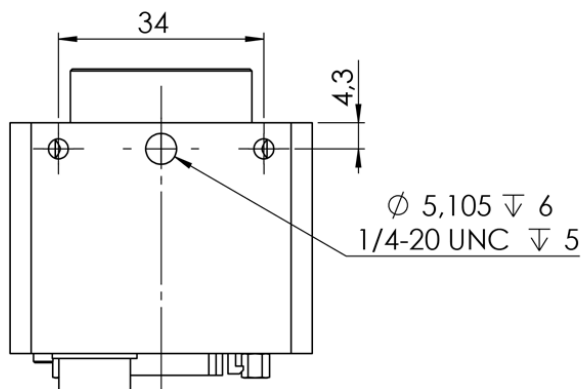

**Back**

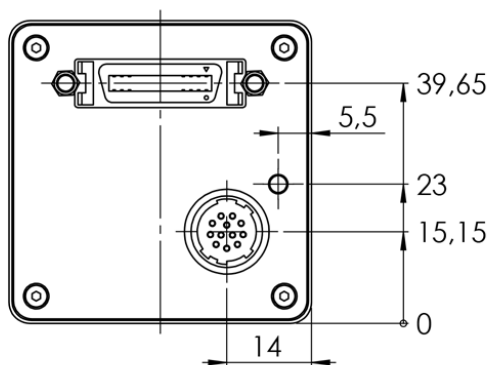

### Cross Section

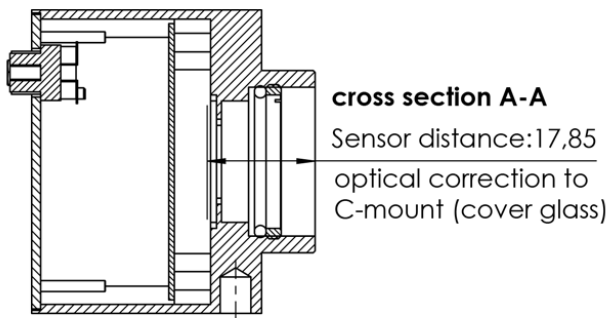

6.5 exo5000\*CL

front

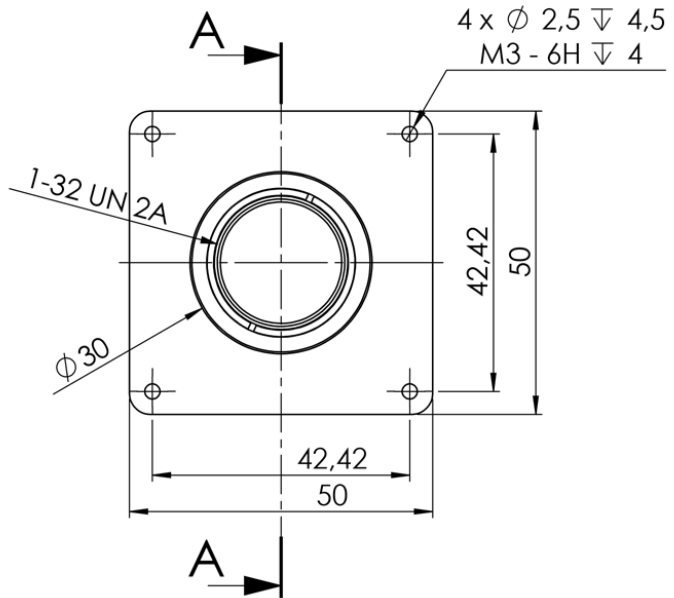

side Left

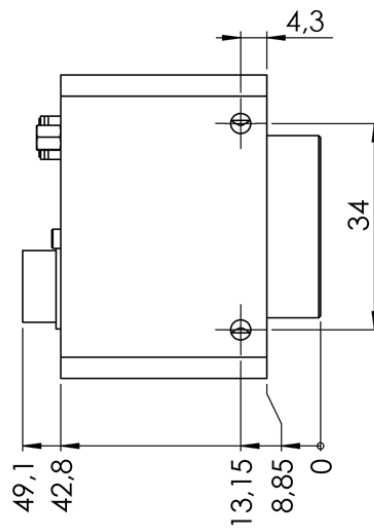

**Side Right**

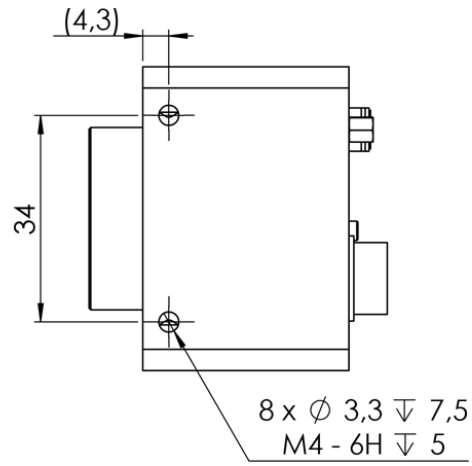

**Top**

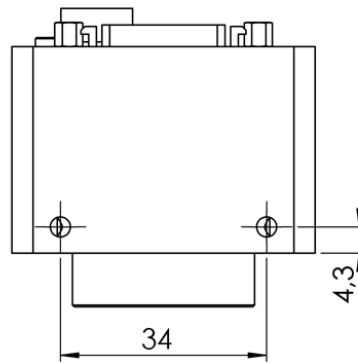

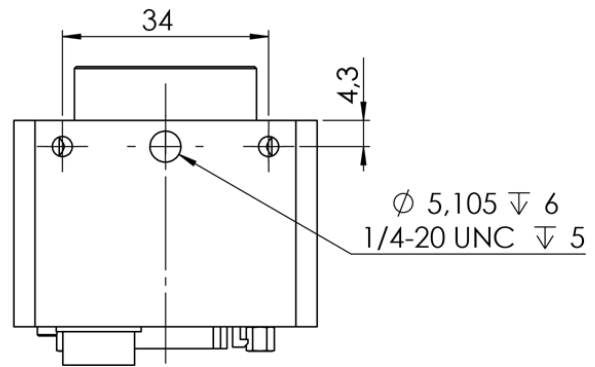
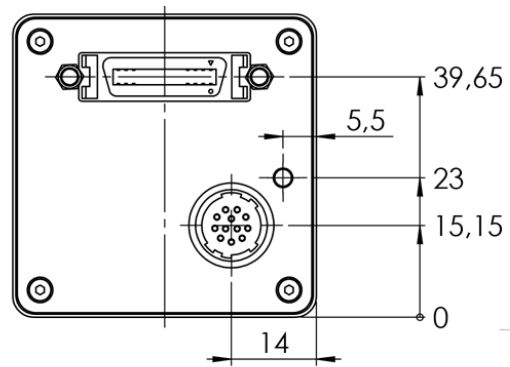
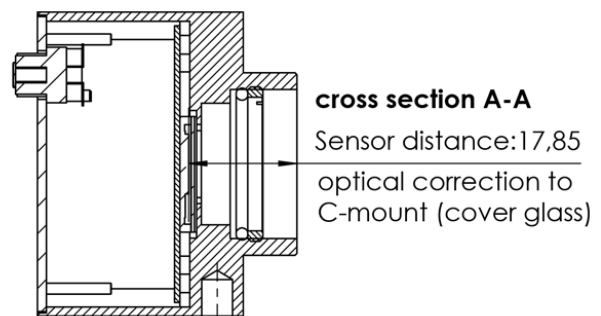
**Bottom****Back****Cross Section**





## 6.6 C & CS Mount

Different back-focus distances from sensor to lens.

- > C-Mount: 17,526 mm
- > CS-Mount: 12,526 mm
- > Diameter: 1 Inch
- > Screw Thread: 1/32 Inch

CS-Mount Cameras accept both types of lenses. C-Mount lenses require a 5mm adapter ring to be fitted. (Also available at SVS-VISTEK)

C-Mount Cameras only accept C mount lenses as the flange to sensor distance does not allow a CS mount lens close enough to the Sensor to achieve a focused image.

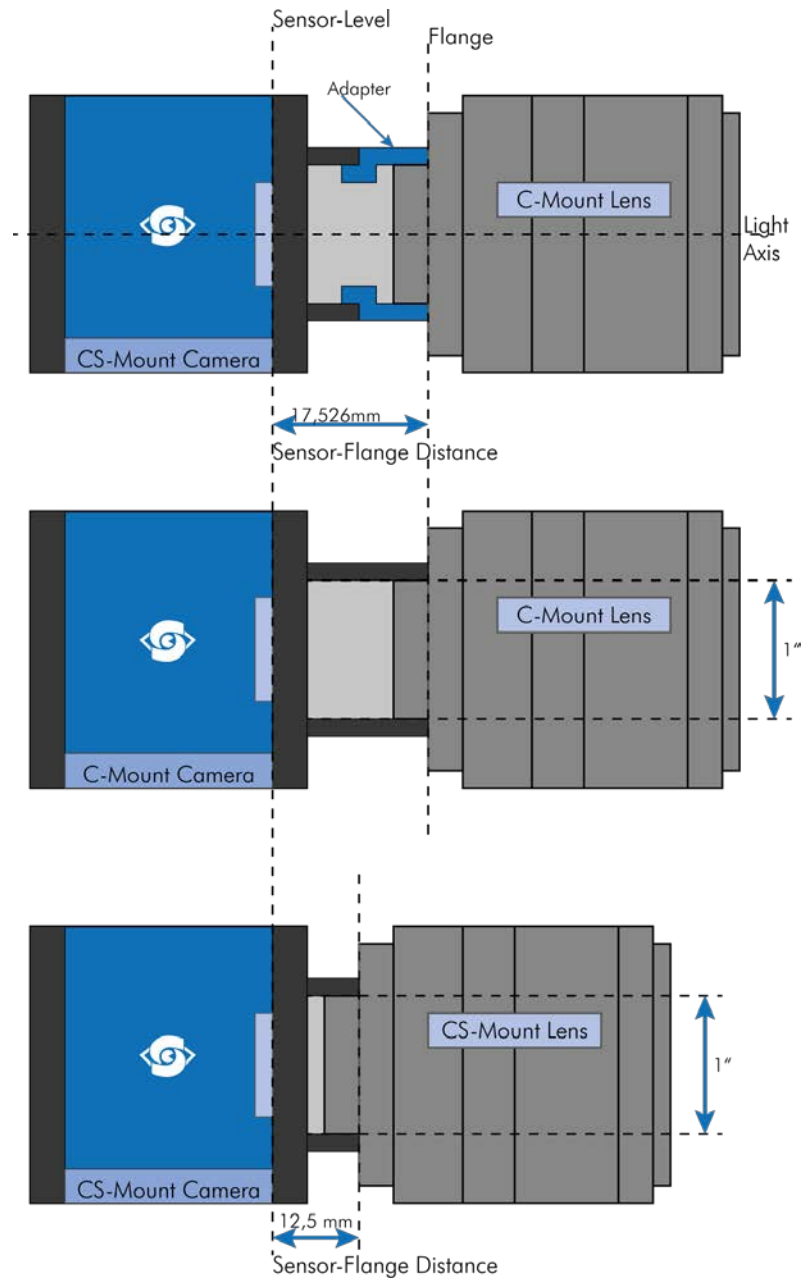

Figure 10: Illustration of C- & CS-Mount differences

---

## 7 Feature-Set

### 7.1 Basic Understanding

#### 7.1.1 Basic Understanding of CMOS Technology

Complementary Metal–Oxide–Semiconductor

Light sensitive semiconductor elements arranged as rows and columns.

Compared to the CCD sensor CMOS doesn't need additional vertical or horizontal readout registers. Every light sensitive element is directly addressed. In-stead of a charge, a voltage is sampled and converted by the ADC.

#### Conventional CMOS sensor front-illuminated

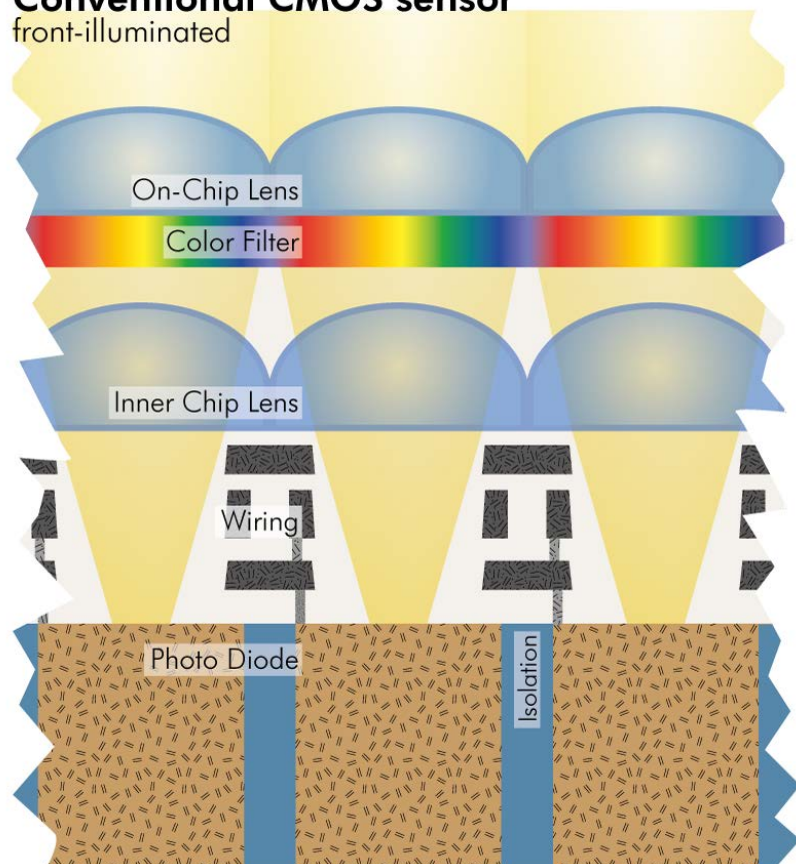

Figure 11: Illustration of conventional CMOS sensor technique

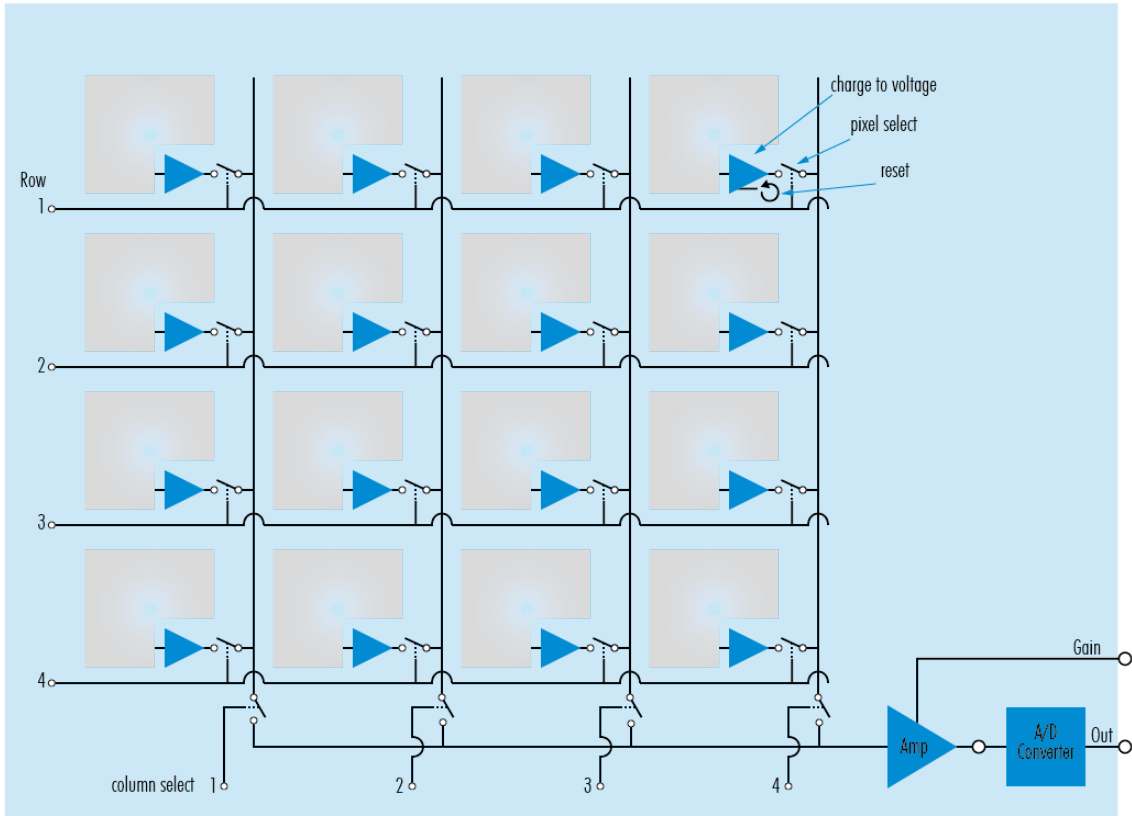

Figure 12: Illustration of CMOS on chip processing

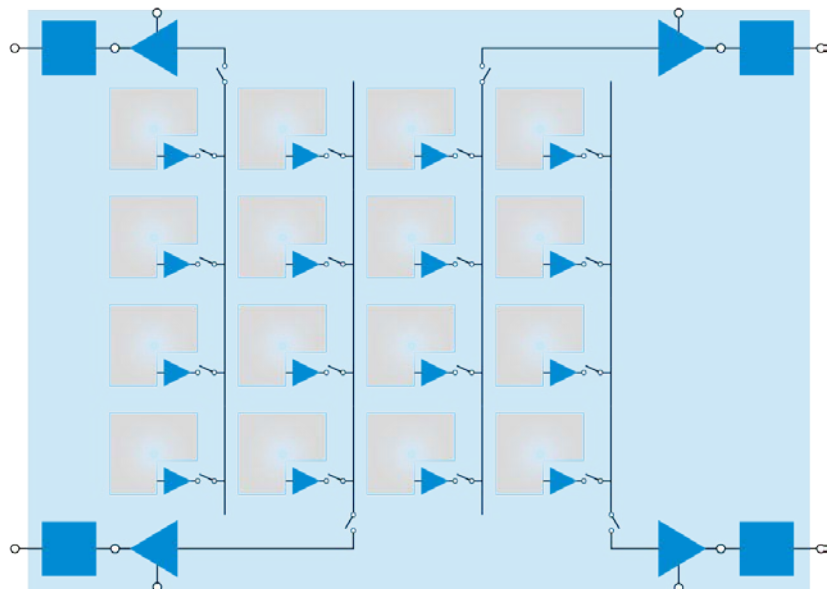

Figure 13: Illustration of CMOS four channel output  
Actual readout order differs from sensor to sensor.

### Sony IMX readout technology

IMX technology from Sony is based on their experiences in CCD technology. Using an architecture based on an interline transfer sensor the vertical shift register is used as an analog memory.

By shifting the electrons into the on pixel memory more time can be spend on 'counting' the electrons. So a **correlated double sampling** can be done twice. Once on the pixel and secondly during the A/D conversion. This is why the IMX series is recommended as one of the best signal-to-noise-ratio sensors in the world.

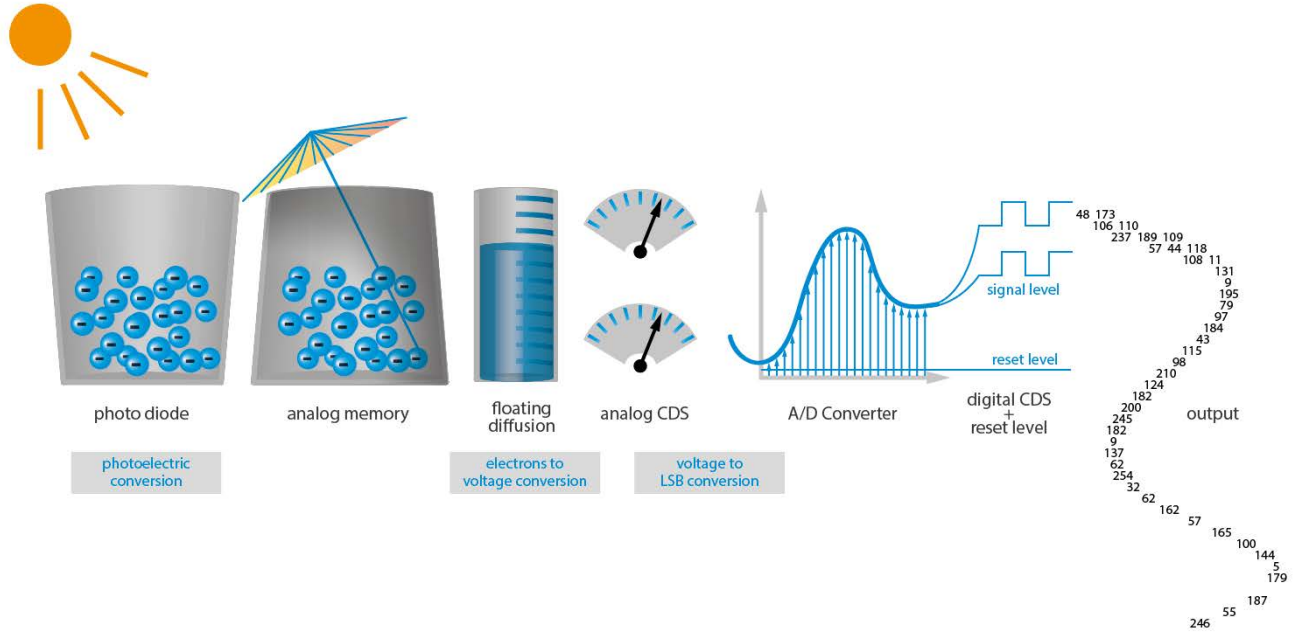



Figure 14: Rolling shutter with fast moving object details

### 7.1.2 Global Shutter / Progressive Scan

Unlike rolling shutter or interlaced scan modes all pixels are exposed at the same time. Fast moving objects will be captured without showing movement distortion.



Figure 15: motion blur



Figure 16: rolling shutter with moving objects



Figure 17: interlaced effect

### 7.1.3 Frames per Second

Frames per second, or frame rate describes the number of frames output per second. The inverse (1/ frame rate) defines the frame time.

frame per second	frame time (Exposure)	applicable standard
0,25	4 s	
1	1s	
2	500ms	
20	50 ms	
24	41,6 ms	Cinema
25	40 ms	PAL progressive
29,97	33,366700033... ms	NTSC
30	33,33 ms	NTSC
50	20 ms	PAL interlaced
75	13,33 ms	
100	10 ms	

Virtually any value within the specification can be chosen.

Maximum frame rate depends on:

- > Pixel clock
- > Image size
- > Tap structure
- > Data transport limitation
- > Processing time

### 7.1.4 Acquisition and Processing Time

The whole period of time a picture is exposed, transferred and processed can differ and takes longer.

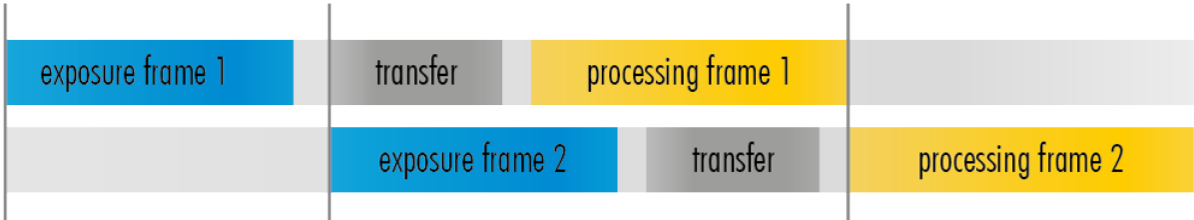

### 7.1.5 Exposure

See various exposure and timing modes in chapter: [Basic capture modes](#).

Combine various exposure timings with PWM LED illumination, refer to [sequencer](#).

### Setting Exposure time

Exposure time can be set by width of the external or internal triggers or programmed by a given value.

### 7.1.6 Auto Luminance

Auto Luminance automatically calculates and adjusts exposure time and gain, frame-by-frame.

The auto exposure or automatic luminance control of the camera signal is a combination of an automatic adjustment of the camera exposure time (electronic shutter) and the gain.

The first priority is to adjust the exposure time and if the exposure time range is not sufficient, gain adjustment is applied. It is possibility to pre-define the range (min. / max. -values) of exposure time and of gain.

The condition to use this function is to set a targeted averaged brightness of the camera image. The algorithm computes a gain and exposure for each image to reach this target brightness in the next image (control loop). Enabling this functionality uses always both – gain and exposure time.

#### Limitation

As this feature is based on a control loop, the result is only useful in an averaged, continuous stream of images. Strong variations in brightness from one image to next image will result in a swing of the control loop. Therefore it is not recommended to use the auto-luminance function in such cases.

### 7.1.7 Bit-Depth

Values of brightness are internally represented by numbers. Numbers are represented by bytes, consisting out of single bits. The number of bits for brightness representation is limiting the number of brightness values or colour values that can be represented. Bit depth defines how many unique colors or grey levels are available in an image after digitization. The number of bits used to quantify limits the number of levels to be used.

e.g.: 4 bits limits the quantification levels to  $2^4 = 16$ .

Each pixel can represent 16 grey levels

8 bits	to	$2^8$	=	256 values per pixel
12 bits	to	$2^{12}$	=	4096 values per pixel
16 bit	to	$2^{16}$	=	65536 values per pixel

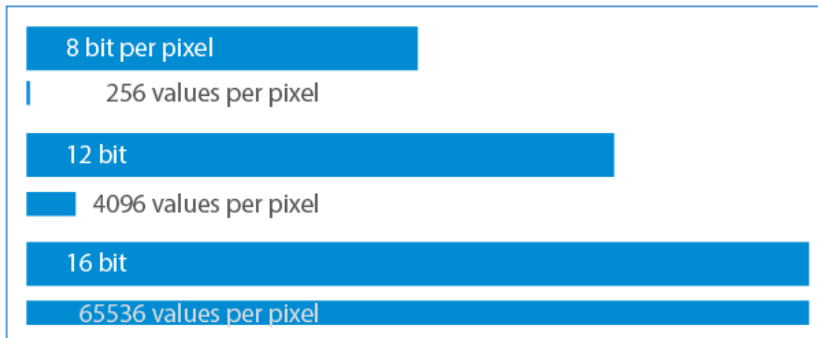

Figure 18: illustration of rising amount of values/gray scales by increasing the bit format

Every additional bit doubles the number for quantification.

SVCam output is 8, 12 or 16 bit, depending on your camera model and the way you read the values from the camera.

Be aware that increasing the bit format from 8 to 12 bit also increases the total amount of data. According to the interface framerates can be limited with higher bit

depth values.

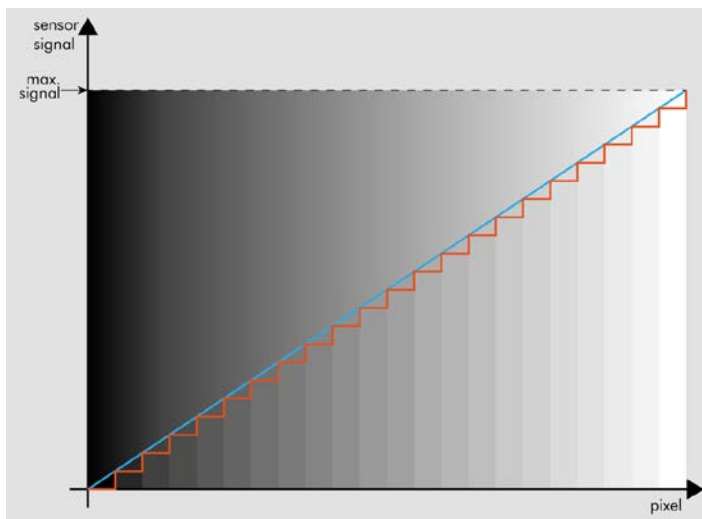

Figure 19: Simplified illustration of a quantification graph screen or in print.

As SVCam's export pure RAW-format only, color will be created on the host computer in accordance with the known Bayer-pattern by computing the brightness values into colour values..



Figure 20: illustration of shade difference in 8 bit format

As shown in figure 21 differences in shades of gray are hardly visible on





Figure 22: Figure of original picture - black & white



Figure 23: Figure of quantification with 6 shades of gray (reduced colour depth)

### 7.1.8 Color

Color cameras are identical to the monochrome versions. The color pixels are transferred in sequence from the camera, in the same manner as the monochrome, but considered as “raw”-format.

The camera sensor has a color mosaic filter called “Bayer” filter pattern named after the person who invented it. The pattern alternates as follows:

E.g.: First line: GRGRGR... and so on. (R=red, B=blue, G=green)  
Second line: BGBGBG... and so on. Please note that about half of the pixels are green, a quarter red and a quarter blue. This is due to the maximum sensitivity of the human eye at about 550 nm (green).

Using color information from the neighboring pixels the RG and B values of each pixel is interpolated by software. E.g. the red pixel does not have information of green and blue components. The performance of the image depends on the software used.

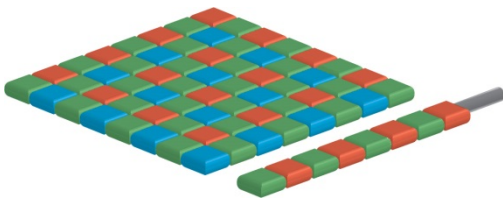

Figure 24: CCD with Bayer Pattern



#### NOTICE

It is recommended to use a IR cut filter for color applications!

### White Balance

The human eye adapts to the definition of white depending on the lighting conditions. The human brain will define a surface as white, e.g. a sheet of paper, even when it is illuminated with a bluish light.

White balance of a camera does the same. It defines white or removes influences of a color tint in the image.

Influences normally depend on the light source used. These tints are measured in Kelvin (K) to indicate the color temperature of the illumination.

Light sources and their typical temperatures:

	Temperature	Common Light Source
	10.000 – 15.000 K	Clear Blue Sky
	6.500 – 8.000 K	Cloudy Sky / Shade
	5.500 – 6500 K	Noon Sunlight
	5.000 – 5.500 K	Average Daylight
	4.000 – 5.000 K	Electronic Flash
	4.000 – 5.000 K	Fluorescent Light
	3.000 – 4.000 K	Early AM / Late PM
	2.500 – 3.000 K	Domestic Lightning
	1.000 – 2.000 K	Candle Flame

Figure 25: Table of color temperatures

### 7.1.9 Resolution – active & effective

As mentions in the specifications, there is a difference between the active and the effective resolution of almost every sensor. Some pixels towards the borders of the sensor will be used only to calibrate the sensor values.

These pixels are totally darkened. The amount of dark current in these areas is used to adjust the offset.

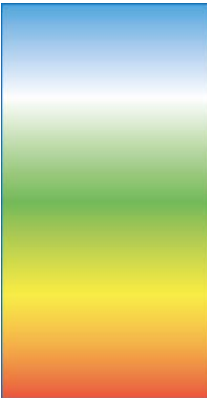
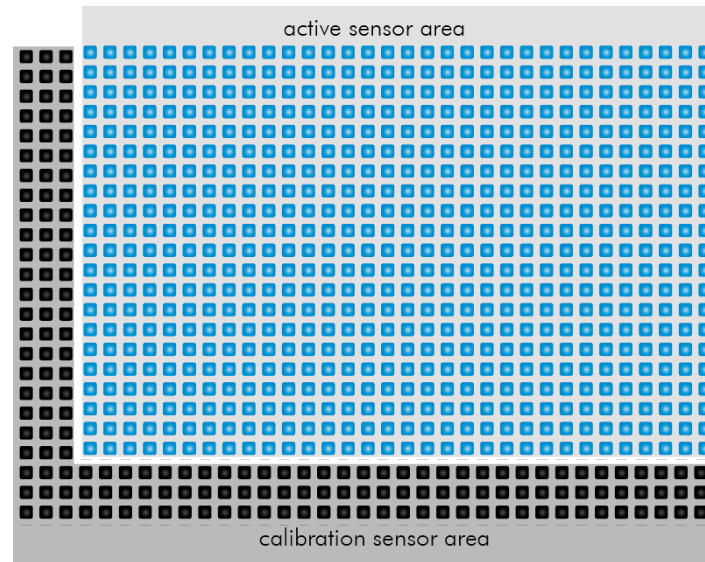

Figure 26: Illustration of active and effective sensor pixels

### 7.1.10 Gain

Setting gain above 0 dB (default) is another way to boost the signal coming from the sensor. Especially useful for low light conditions.

Setting Gain amplifies the signal of individual or binned pixels before the ADC.

Referring to Photography adding gain corresponds to increasing ISO.

add 6 dB	double ISO value
6 dB	400 ISO
12 dB	800 ISO
18 dB	1600 ISO
24 dB	3200 ISO

Figure 27: Table of dB and corresponding ISO



#### NOTICE

Gain also amplifies the sensor's noise. Therefore, gain should be last choice for increasing image brightness. Modifying gain will not change the camera's dynamic range.

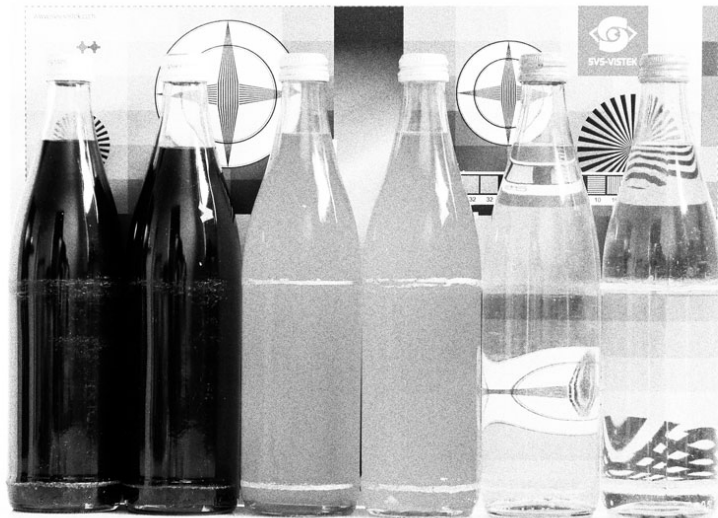

Figure 28: noise caused by increasing gain excessively

### Auto Gain

For automatically adjusting Gain please refer to [Auto Luminance](#).

### 7.1.11 Image Flip

Images can be mirrored horizontally or vertically. Image flip is done inside the memory of the camera, therefore not increasing the CPU load of the PC.



Figure 29: Figure of original image



Figure 30: Figure of image horizontally flipped



Figure 31: Figure of image vertically flipped

## 7.2 Camera Features

### Tap Reconstruction on Camera Link

Due to the sequence of arriving pixel information the frame grabber has to “reconstruct” the pixel information in order to display the image correctly.

#### 7.2.1 System Clock Frequency

Default system clock frequency in almost every SVCam is set to 66.6 MHz. To validate your system frequency: refer to: [specifications](#).

Using the system clock as reference of time, time settings can only be made in multiples of 15 ns.

$$t = \frac{1}{66.6 \text{ MHz}} = \frac{1}{66\,666\,666.6 \frac{1}{s}} = 15 \cdot 10^{-9} \text{ s} = 15 \text{ ns}$$



#### NOTICE

Use multiples of 15 ns to write durations into camera memory

#### 7.2.2 Temperature Sensor

A temperature sensor is installed on the mainboard of the camera.

To avoid overheating, the temperature is constantly monitored and read. Besides software monitoring, the camera indicates high temperature by a red flashing LED. (See flashing LED codes)

### 7.2.3 Basic Capture Modes

#### Free Running

Free running (fixed frequency) with programmable exposure time. Frames are readout continuously and valid data is indicated by LVAL for each line and FVAL for the entire frame.

Mode 0: Free Running with Programmable Exposure Time

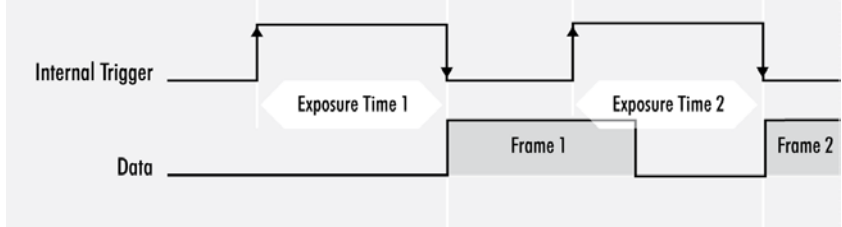

There is no need to trigger the camera in order to get data. Exposure time is programmable via serial interface and calculated by the internal logic of the camera.



#### NOTICE

The fundamental signals are:  
Line Valid: LVAL, Frame Valid: FVAL,  
And in case of triggered modes: trigger input.

#### Triggered Mode (pulse width)

External trigger and pulse-width controlled exposure time. In this mode the camera is waiting for an external trigger, which starts integration and readout. Exposure time can be varied using the length of the trigger pulse (rising edge starts integration time, falling edge terminates the integration time and starts frame read out). This mode is useful in applications where the light level of the scene changes during operation. Change of exposure time is possible from one frame to the next.

Mode 1: External Trigger with Pulse Width Exposure Control (overlap)

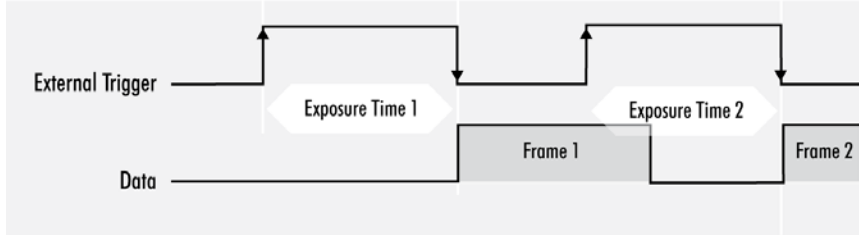

Exposure time of the next image can overlap with the frame readout of the current image (rising edge of trigger pulse occurs when FVAL is high). When this happens: the start of exposure time is synchronized to the falling edge of the LVAL signal.

Mode 1: External Trigger with Pulse Width Exposure Control (non overlap)

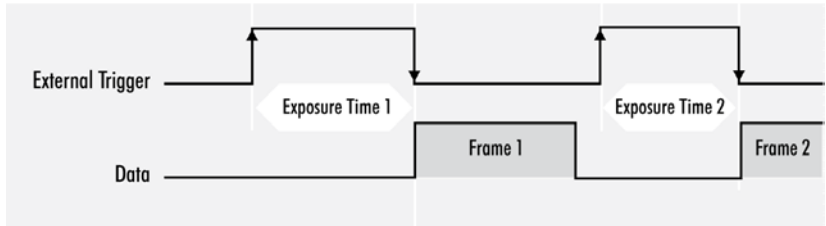

When the rising edge of trigger signal occurs after frame readout has ended (FVAL is low) the start of exposure time is not synchronized to LVAL and exposure time starts after a short and persistent delay.

The falling edge of the trigger signal must always occur after readout of the previous frame has ended (FVAL is low).

### External Trigger (Exposure Time)

External trigger with programmable exposure time. In this mode the camera is waiting for an external trigger pulse that starts integration, whereas exposure time is programmable via the serial interface and calculated by the internal microcontroller of the camera.

At the rising edge of the trigger the camera will initiate the exposure.

The software provided by SVS-Vistek allows the user to set exposure time e.g. from 60  $\mu$ s 60 Sec (camera type dependent).

Exposure time of the next image can overlap with the frame readout of the current image (trigger pulse occurs when FVAL is high). When this happens, the start of exposure time is synchronized to the negative edge of the LVAL signal (see figure)

Mode 2: External Trigger with Programmable Exposure Time (overlap)

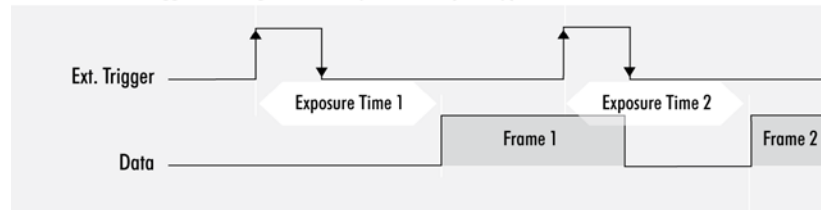

When the rising edge of trigger signal occurs after frame readout has ended (FVAL is low), the start of exposure time is not synchronized to LVAL and exposure time starts after a short and persistent delay.

Mode 2: External Trigger with Programmable Exposure Time (non overlap)

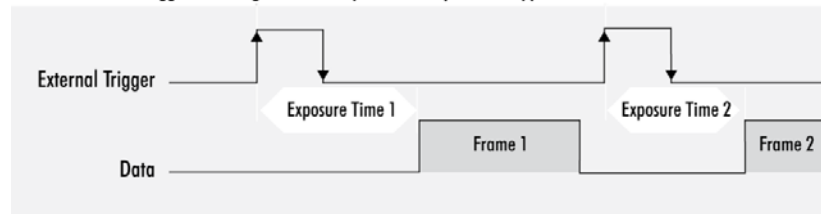

Exposure time can be changed during operation. No frame is distorted during switching time. If the configuration is saved to the EEPROM, the set exposure time will remain also when power is removed.

### Detailed Info of External Trigger Mode

Diagrams below are equivalent for CCD and CMOS technique.

Mode 1: External Trigger with Pulse Width Exposure Control (non overlap)

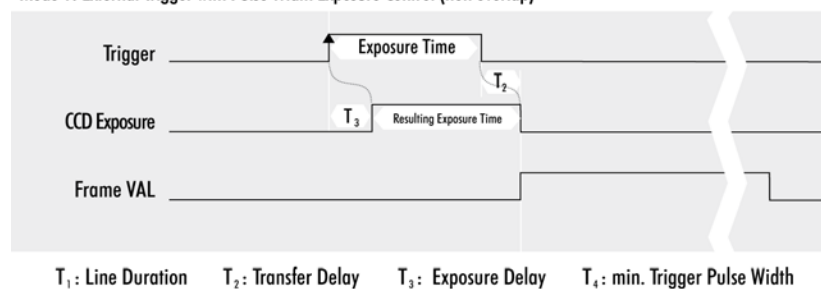



Mode 1: External Trigger with Pulse Width Exposure Control (overlap)

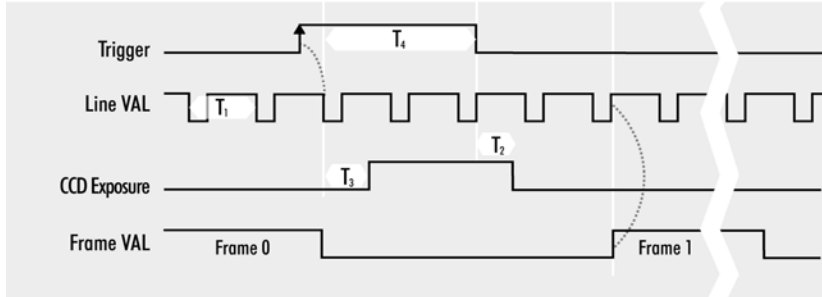

$T_1$ : Line Duration     $T_2$ : Transfer Delay     $T_3$ : Exposure Delay     $T_4$ : min. Trigger Pulse Width

Mode 2: External Trigger with Programmable Exposure Time (non overlap)

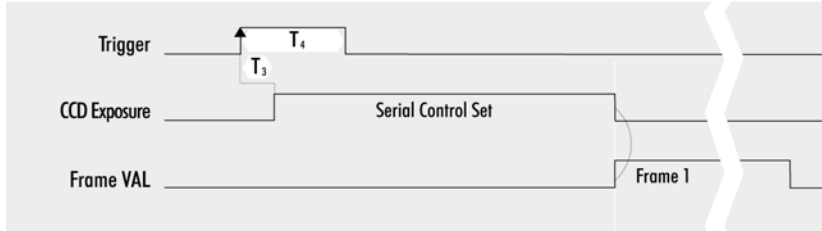

$T_1$ : Line Duration     $T_2$ : Transfer Delay     $T_3$ : Exposure Delay     $T_4$ : min. Trigger Pulse Width

Mode 2: External Trigger with Programmable Exposure Time (overlap)

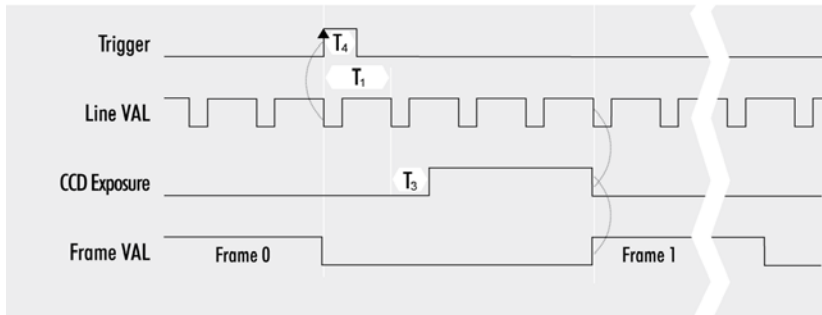

$T_1$ : Line Duration     $T_2$ : Transfer Delay     $T_3$ : Exposure Delay     $T_4$ : min. Trigger

## Software Trigger

Trigger can also be initiated by software (serial interface).



### NOTICE

Software trigger can be influenced by jitter. Avoid Software trigger at time sensitive applications

### 7.2.4 LookUp Table

The LookUp Table Feature (LUT) lets the user define certain values to every bit value that comes from the ADC.

To visualize a LUT a curve diagram can be used, similar to the diagrams used in photo editing software.

The shown custom curve indicates a contrast increase by applying an S-shaped curve. The maximum resolution is shifted to the mid-range. Contrasts in this illumination range is increased while black values will be interpreted more black and more of the bright pixels will be displayed as 100 % white...

For further Information about curves and their impact on the image refer to our homepage: [Knowledge Base – LUT](#)

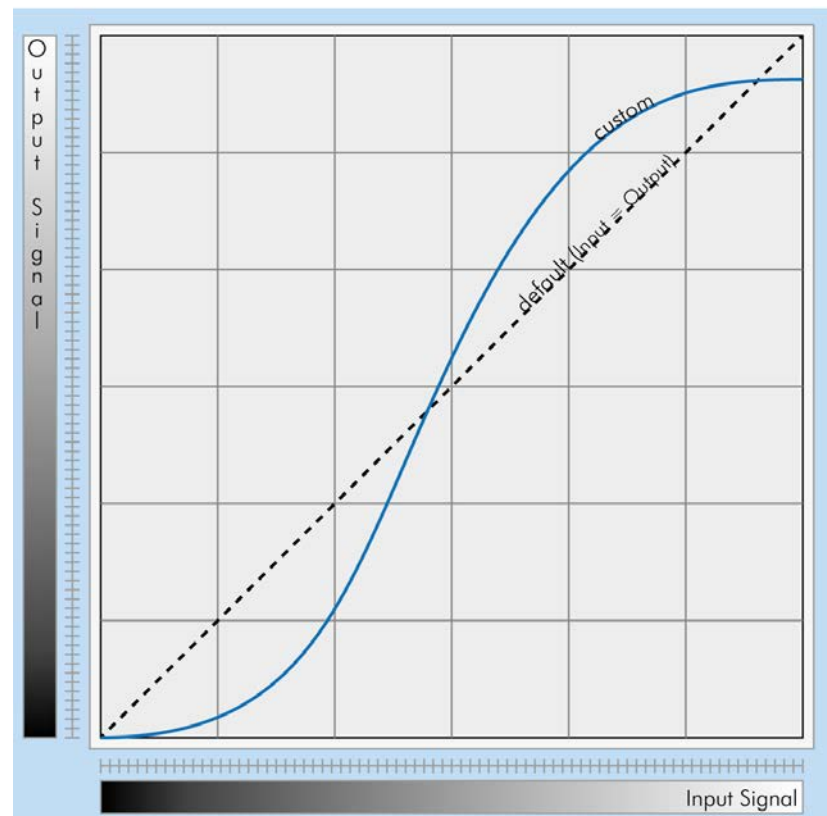

Figure 32: illustration of a custom LUT adding contrast to the midtones



#### NOTICE

LUT implementation reduces bit depth from 12 bit to 8 bit on the output.

## Gamma Correction

Using the LookUp Table makes it also possible to implement a logarithmic correction. Commonly called Gamma Correction.

Historically Gamma Correction was used to correct the illumination behavior of CRT displays, by compensating brightness-to-voltage with a Gamma value between 1,8 up to 2,55.

The Gamma algorithms for correction can simplify resolution shifting as shown seen above.

Input & Output signal range from 0 to 1

$$\text{Output-Signal} = \text{Input-Signal}^{\text{Gamma}}$$

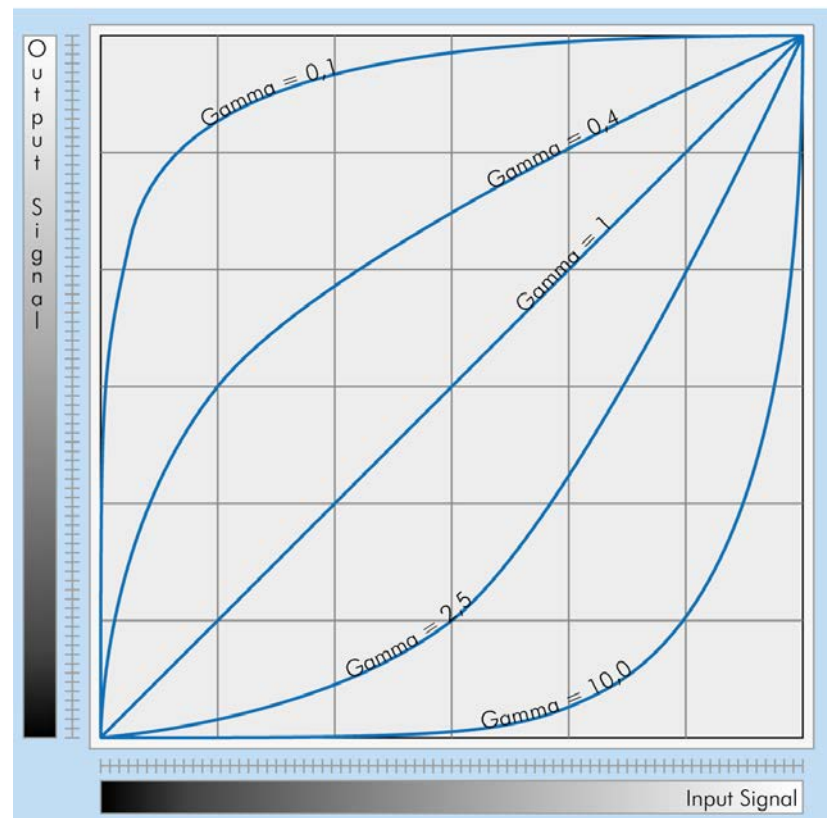

Figure 33: illustration of several gamma curves comparable to a LUT

Gamma values less than 1.0 map darker image values into a wider range.

Gamma values greater than 1.0 do the same for brighter values.



### NOTICE

Gamma Algorithm is just a way to generate a LUT. It is not implemented in the camera directly..

### 7.2.5 ROI / AOI

In Partial Scan or Area-Of-Interest or Region-Of-Interest (ROI) -mode only a certain region will be read.

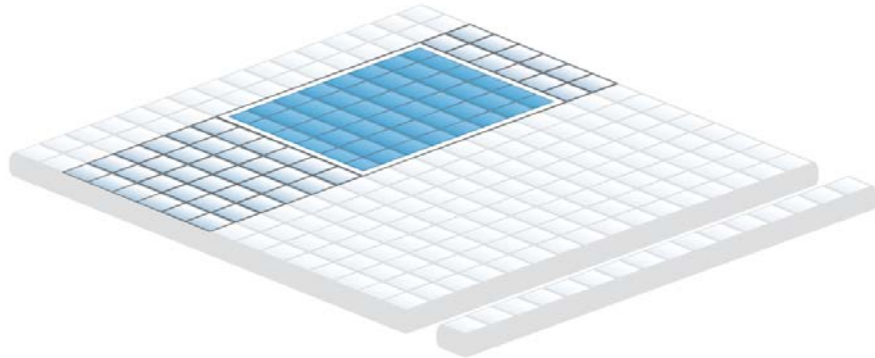

Figure 34: Illustration of AOI limitation on a CCD sensor

Selecting an AOI will reduce the number of horizontal lines being read. This will reduce the amount of data to be transferred, thus increasing the maximum speed in term of frames per second.

With CCD sensors, setting an AOI on the left or right side does not affect the frame rate, as lines must be read out completely.

In CMOS Sensors, AOI can be chosen, too.

## 7.3 I/O Features

### 7.3.1 Assigning I/O Lines – IOMUX

The IOMUX is best described as a switch matrix. It connects inputs, and outputs with the various functions of SVCam I/O. It also allows combining inputs with Boolean arguments.

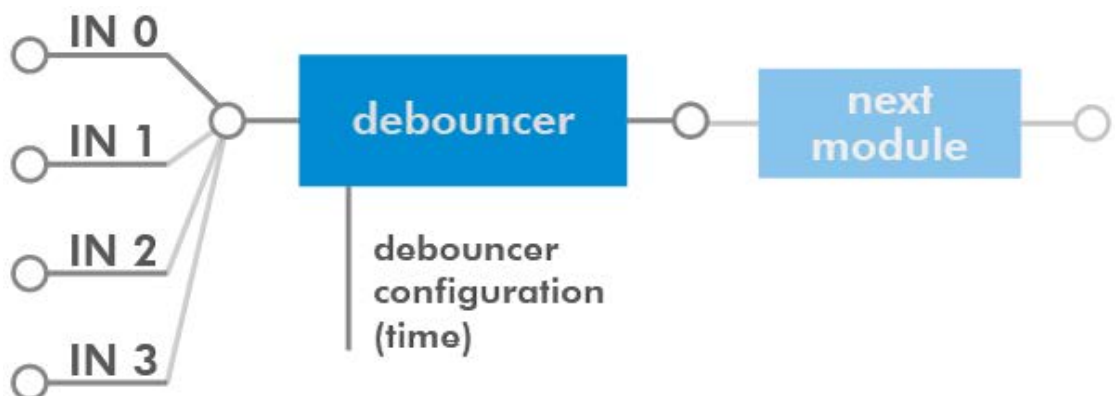

Figure 35: "IN0" connected to "debouncer"

LineSelector translation

Line0	Output0
Line1	Output1
Line2	Output2
Line3	Output3
Line3	Output4
Line5	Uart In
Line6	Trigger
Line7	Sequencer
Line8	Debouncer
Line9	Prescaler
Line10	Input0
Line11	Input1
Line12	Input2
Line13	Input3
Line14	Input4
Line15	LogicA
Line16	LogicB
Line17	LensTXD
Line18	Pulse0
Line19	Pulse1
Line20	Pulse2
Line21	Pulse3
Line22	Uart2 In

The input and output lines for Strobe and Trigger impulses can be arbitrarily assigned to actual [data lines](#). Individual assignments can be stored persistently to the EPROM. Default setting can be restored from within the Camera.

Note:

If you connect the camera with a non-SVS-Vistek GigEVision client, you might not see the clearnames of the lines, but only line numbers. In this case, use this list of line names

Refer to pinout in [input / output connectors](#) when physically wiring.

Also the IOMUX can be illustrated as a three dimensional dice. Long address spaces indicate which signals are routed to witch module within the camera.

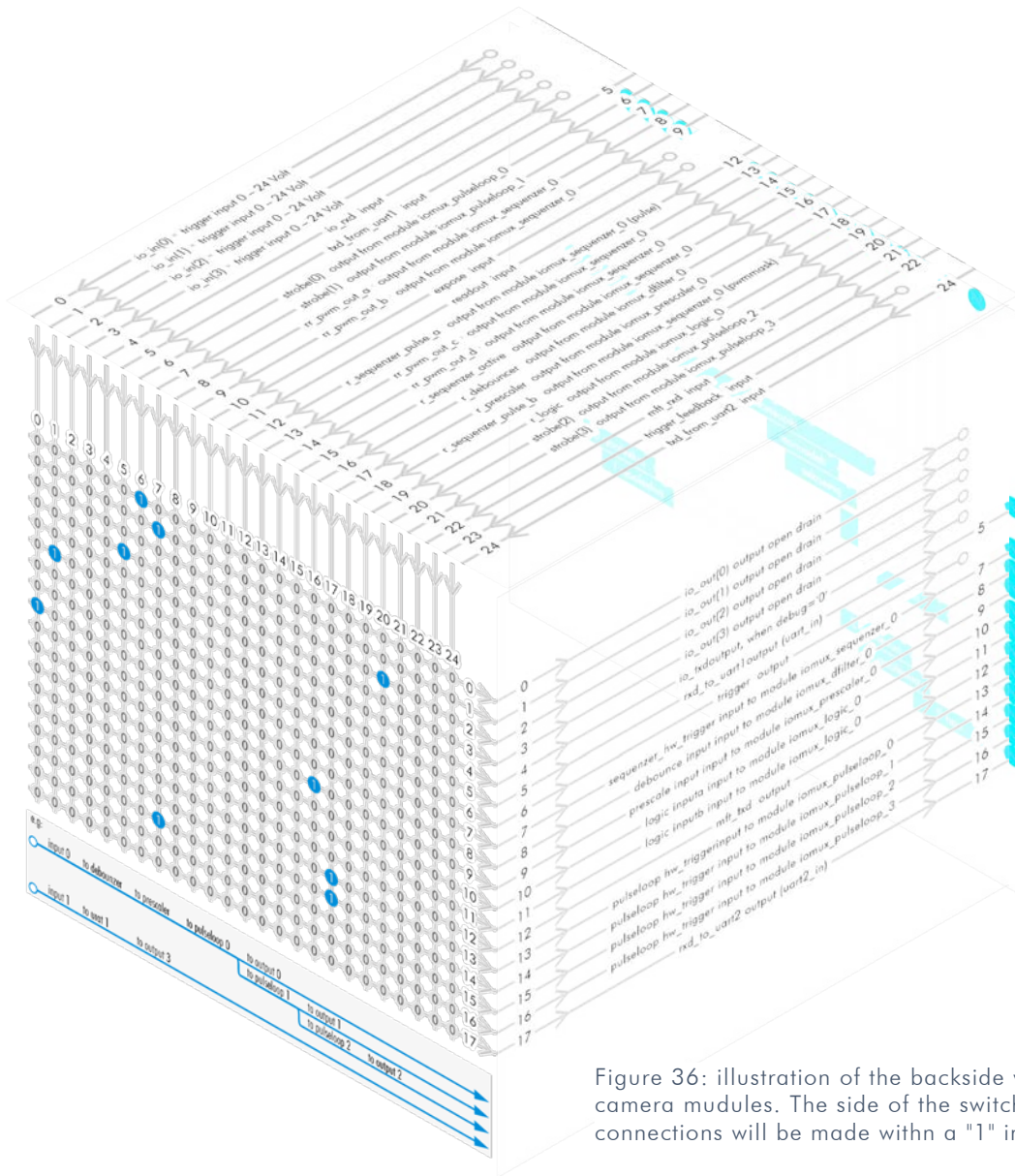
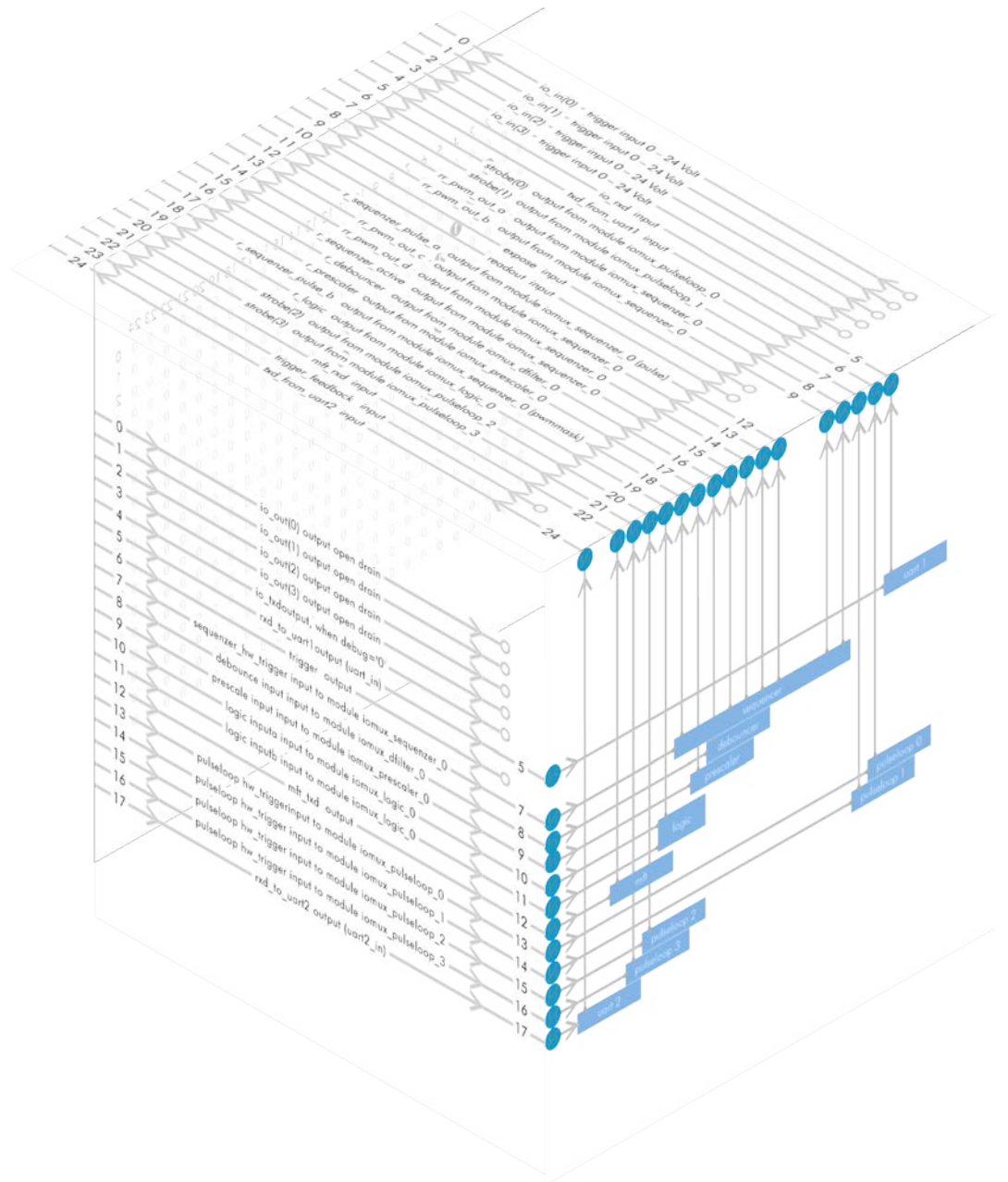

Figure 36: illustration of the backside view of the camera modules. The side of the switch matrix. connections will be made with a "1" instead of a "0"

Figure 37: illustration of frontside view to the camera modules.

Lines with open end indicate physical in- and outputs



### input vector to switch matrix

nr.	name	description
0	io_in(0)	trigger input 0 – 24 Volt / RS-232 / opto *
1	io_in(1)	trigger input 0 – 24 Volt / RS-232 / opto *
2	io_in(2)	trigger input 0 – 24 Volt / RS-232 / opto *
3	io_in(3)	trigger input 0 – 24 Volt / RS-232 / opto *
4	io_rxd input	
5	txd_from_uart1	input
6	strobe(0)	output from module iomux_pulseloop_0
7	strobe(1)	output from module iomux_pulseloop_1
8	rr_pwm_out_a	output from module iomux_sequenzer_0
9	rr_pwm_out_b	output from module iomux_sequenzer_0
10	expose input	
11	readout input	
12	r_sequenzer_pulse_a	output from module iomux_sequenzer_0 (pulse)
13	rr_pwm_out_c	output from module iomux_sequenzer_0
14	rr_pwm_out_d	output from module iomux_sequenzer_0
15	r_sequenzer_active	output from module iomux_sequenzer_0
16	r_debouncer	output from module iomux_dfilter_0
17	r_prescaler	output from module iomux_prescaler_0
18	r_sequenzer_pulse_b	output from module iomux_sequenzer_0 (pwmmask)
19	r_logic	output from module iomux_logic_0
20	strobe(2)	output from module iomux_pulseloop_2
21	strobe(3)	output from module iomux_pulseloop_3
22	mft_rxd input	
23	trigger_feedback	input
24	txd_from_uart2	input

\* refer to pinout or [specifications](#)



### output vector from switch matrix

nr.	name / register	description
0	io_out(0)	output open drain
1	io_out(1)	output open drain
2	io_out(2)	output open drain *
3	io_out(3)	output open drain *
4	io_txd	output, when debug='0'
5	rxd_to_uart1	output (uart_in)
6	trigger	output
7	sequenzer_hw_trigger	input to module iomux_sequenzer_0
8	debounce input	input to module iomux_dfilter_0
9	prescale input	input to module iomux_prescaler_0
10	logic inputa	input to module iomux_logic_0
11	logic inputb	input to module iomux_logic_0
12	mft_txd	output
13	pulseloop_hw_trigger	input to module iomux_pulseloop_0
14	pulseloop_hw_trigger	input to module iomux_pulseloop_1
15	pulseloop_hw_trigger	input to module iomux_pulseloop_2
16	pulseloop_hw_trigger	input to module iomux_pulseloop_3
17	rxd_to_uart2	output (uart2_in)

\* for physical number of open drain outputs refer to pinout or [specifications](#)

## Example of an IOMUX configuration

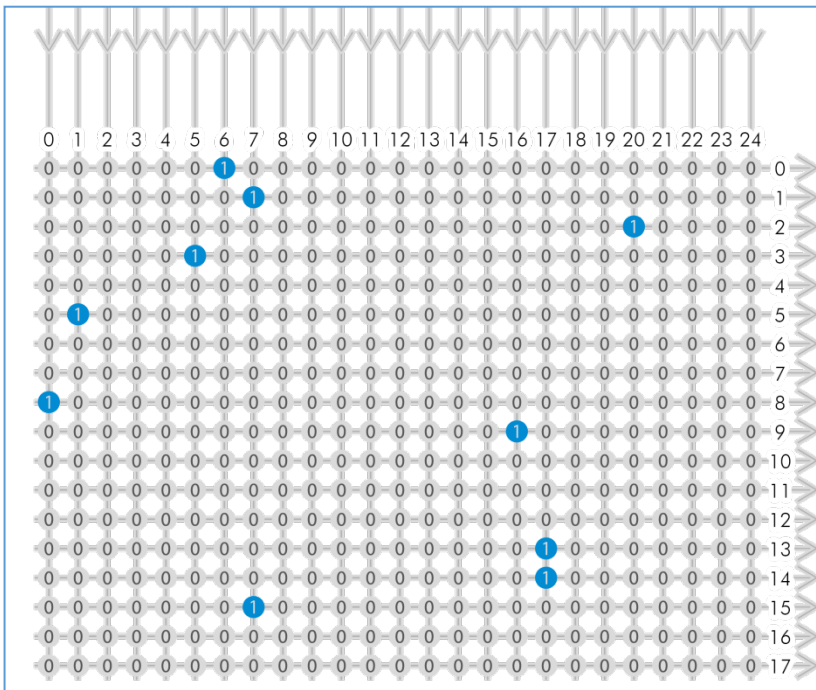

- > The trigger signal comes in on line 0
- > Debounce it.  
connect line 0 to 8:  
10000000000000000000000000000000  
signal appears again on line 15 –  
debouncer out
- > Use the prescaler to act only on every second pulse.  
connect line 16 to 9.  
000000000000000000001000000000  
signal appears again on line 17 –  
debouncer out
- > Configure a strobe illumination with pulseloop module 0  
connect line 17 to 13  
signal from pulse loop module 0  
appears on line 6
- > connect line 6 to 0 (output 0)
- > Set an exposure signal with pulseloop module 1.  
connect line 17 to 6

- > Tell another component that the camera is exposing the sensor.  
connect line 17 to 14  
signal from pulse loop module 1 appears on line 7  
connect line 7 to 1 (output 1)
- > Turn of a light that was ON during the time between two pictures.  
connect line 17 to 15  
invert signal from pulse loop module 2  
it appears on line 20  
connect line 20 to 2 (output 2)

## Inverter & Set-to-1

Inverter and “set to 1” is part of every input and every output of the modules included in the IOMUX.

### INVERTER

The inverter enabled at a certain line provides the reverse signal to or from a module.

### SET TO “1”

With set to “1” enabled in a certain line, this line will provide a high signal no matter what signal was connected to the line before.

### SET TO “1” – INVERS

The inverse of a set to “1” line will occur as a low signal, regardless of the actual signal that came to the inverter module.



### 7.3.2 Strobe Control

Drive LED lights from within your camera. Control them via ethernet.

- > SVCam cameras provide a flash controller integrated into the camera, saving money and hassle
- > Maximum current of up to 3 Amperes @ 40ms
- > High frequency pulse width modulation (PWM) for no flickering
- > Less cables
- > Setting of pulse and duty cycle is controlled via the SVCam program or SVCam library
- > Only one programming interface for camera and flash
- > LED-lights can be controlled over 4 different channels that can be used simultaneously or independent from each other
- > According to the I/O specification of your camera two or four channels can be used as open drain. Refer to [specifications](#).



Figure 1: use the breakout box to simplify your wiring

### 4 IO high voltage drain

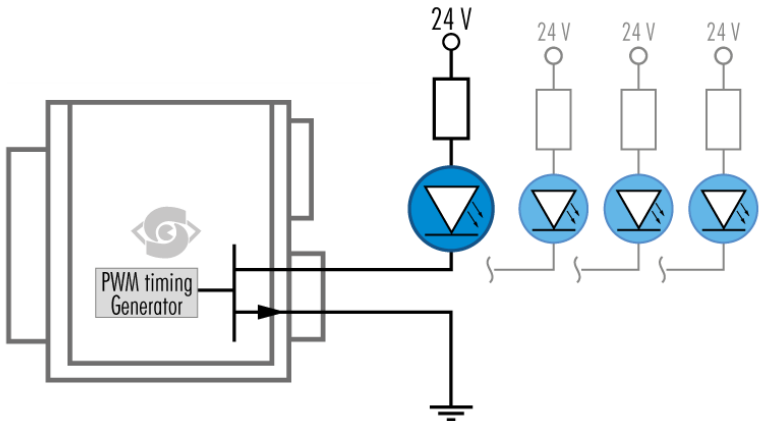

Figure 38: Illustration of four LEDs switched internal by the camera

For detailed connector pin out refer to [Connectors](#).

For further information using the **breakout box** and simplifying OIs refer **SVCam Connectivity** manual. To be found separate within the USP manuals.

**USE RIGHT DIMENSION OF RESISTOR!**

Protect your display from damage by selecting the appropriate resistor dimension. The PWM output will put full operational voltage to the LED display!

**schematic electrical circuit - conventional system single channel**

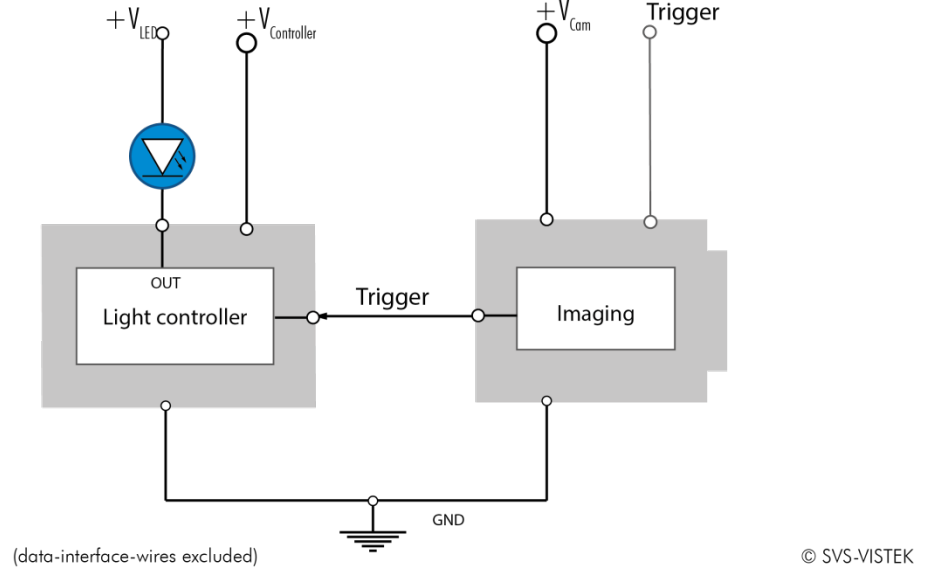

Figure 39: Illustration of conventional schematic electric circuit

**schematic electrical circuit - 4IO single channel**

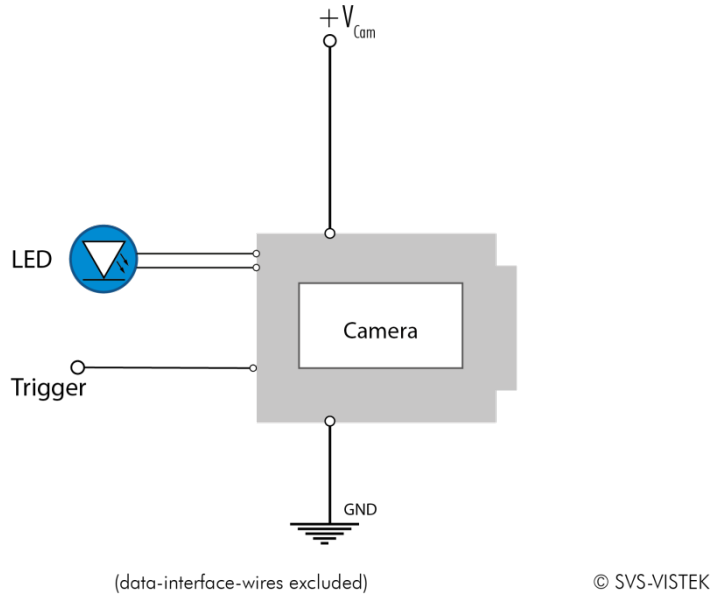

Figure 2: 4IO simplifies light control

### schematic wiring - SVS-VISTEK 4IO with breakout box

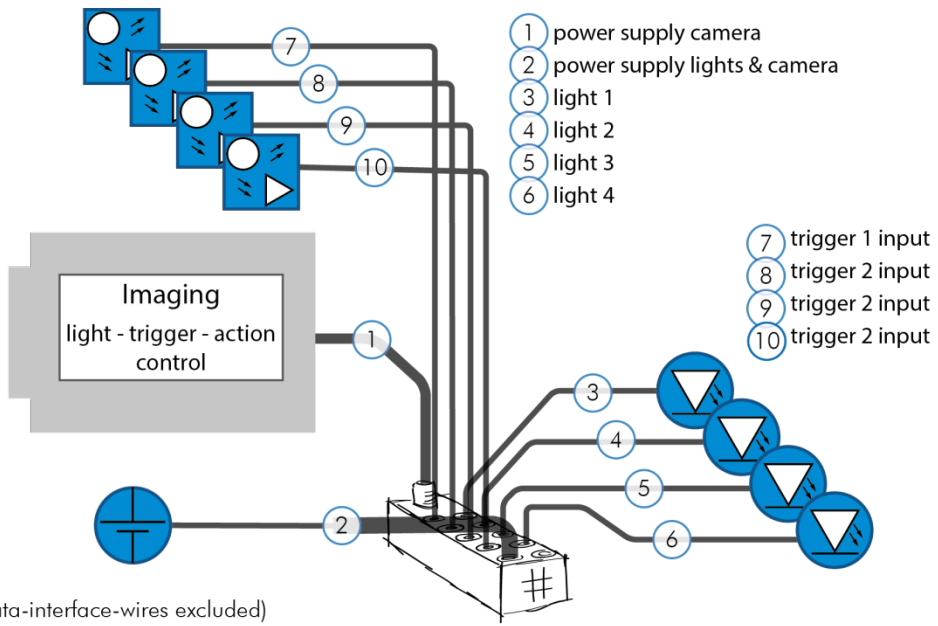

Figure 3: Illustration of schematic wiring with 4IO model using the break out box (matrix)

### The pulseloop module

A fully programmable timer/counter function with four individual pulse generators (pulseloop0 - 3) that can be combined with all SVCam I/O functions, as well as physical inputs and outputs. All timing settings are programmable in 15ns intervals.

#### PROGRAMMABLE PARAMETERS:

- > Trigger source (hardware or software)
- > Edge or level trigger (HW trigger)
- > Pulse output starting on low or high level
- > Pre and post duration time
- > Number of loops

#### EXAMPLE APPLICATIONS

Initiated by an external trigger, the camera drives an LED illumination directly from the open drain output and initiates the camera exposure after a pre-defined delay.

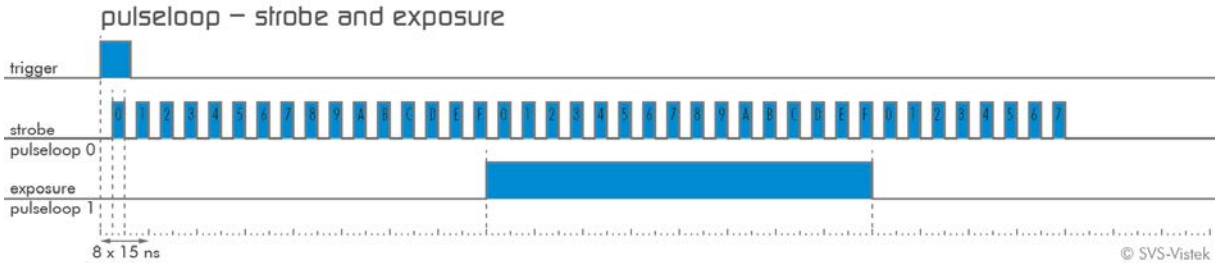

Figure 40: pulseloop for strobe and exposure

#### CAMERA CASCADE

Three cameras are triggered in cascade where the first camera is the master receiving the external trigger, and the master subsequently triggers the two slave cameras.

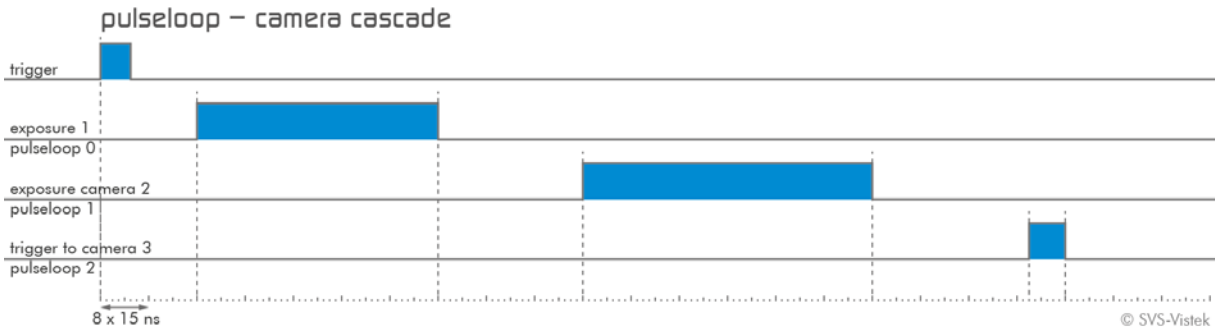
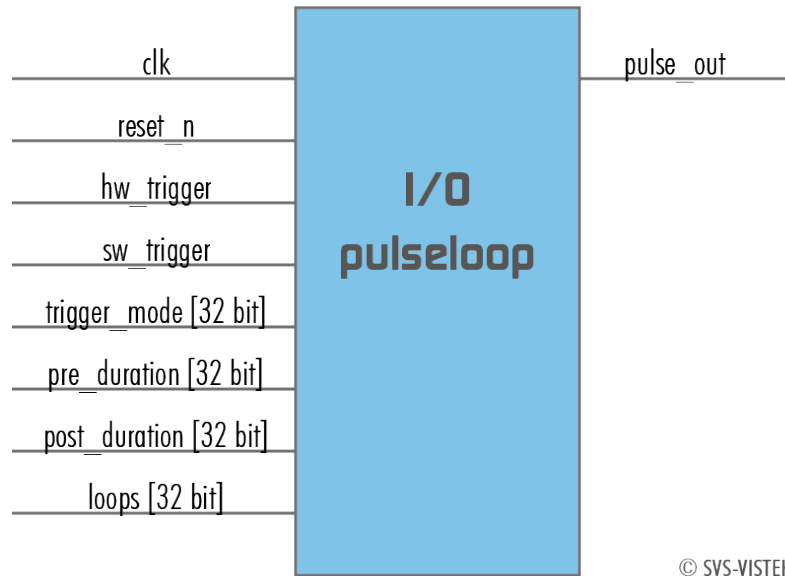

Figure 41: pulseloop – activating three cameras

#### MODULE PULSELOOP



## LEDs in Continuous Mode

## Example Calculation "No Flash" (CW Mode)

Voltage drop at 5 LEDs, 2,2 V per LED (see spec. of LED)	11 V
Max. continuous current (see spec. of LED)	250 mA
Voltage Supply	24 V
Voltage drop at Resistor (24 V – 11 V)	13 V
Pull up Resistor $R = \frac{13 V}{250 mA}$	52 $\Omega$

Total Power ( $P = U \times I$ )	6 W
Power at LEDs (11 V × 250 mA)	2,75 W
Power Loss at Resistor ( 13 V × 250 mA )	3,25 W

**USE RIGHT DIMENSION OF RESISTOR!**

Protect your display from damage by selecting the appropriate resistor dimension. The PWM output will put full operational voltage to the LED display!

## LEDs in Flash Mode

Most LEDs can be operated with much higher currents than spec in flash mode. This will result in more light. Please refer to the specification of your LED panel.

The MOS FETs at "OUT1" and "OUT2" are used like a "switch". By controlling "on time" and "off time" (duty cycle) the intensity of light and current can be controlled.

Current	"time ON" within a 1 Sec	PWM %
0,75 A	500 ms	50 %
1 A	300 ms	33,3 %
2 A	70 ms	7 %
3 A	40 ms	4 %

Example: If pulse is 1.5 A the max. "on" time is 150 mSec. This means the "off" time is 850 mSec. The sum of "time on" and "time off" is 1000 mSec = 1 Sec.



### NOTICE

The shorter the „time on“ – the higher current can be used –the longer LEDs will work.

## Strobe Timing

### 7.3.2.1.1 Exposure Delay

A value, representing the time between the (logical) positive edge of trigger pulse and start of integration time. Unit is 1  $\mu$ s. Default is 0  $\mu$ s.

### 7.3.2.1.2 Strobe Polarity

Positive or negative polarity of the hardware strobe output can be selected.

### 7.3.2.1.3 Strobe Duration

The exposure time of LED lights can be set in  $\mu$ sec. The min duration is 1  $\mu$ sec. The longest time is 1 second.

### 7.3.2.1.4 Strobe Delay

The delay between the (logical) positive edge of trigger pulse and strobe pulse output can be set in  $\mu$ sec. Unit is 1  $\mu$ s. Default is 0  $\mu$ s.



## Strobe Control Example Setup

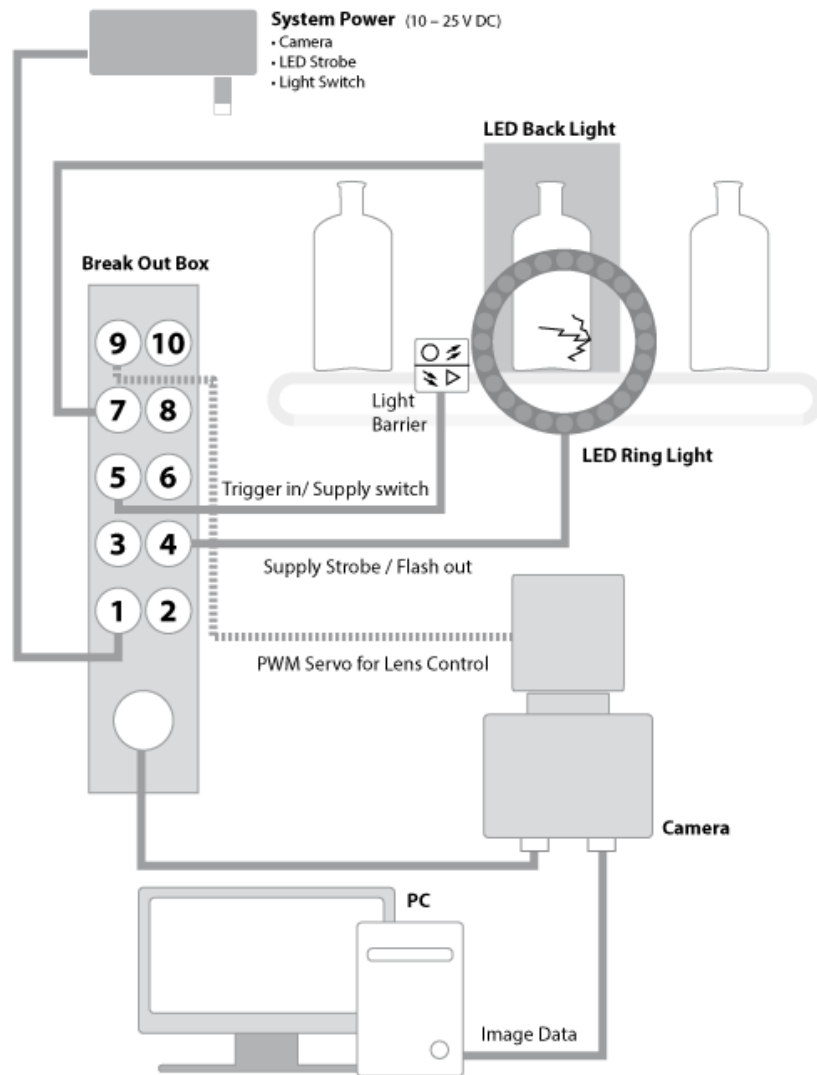

Figure 42: Illustration of an application using the 4IO

### 7.3.3 Sequencer

The sequencer is used when different exposure settings and illuminations are needed in a row.

E.g. the scenario to be captured may occur in three different versions and should therefore be recorded with three different light source settings. Each scenario/interval needs different illumination and exposure time.

The Sequencer allows not only detecting which scenario just appeared. Depending on the scenario there will be one optimal image for further analyzes.

Values to set	Unit	Description
Sequencer Interval	$\mu s$	Duration of the Interval
Exposure Start	$\mu s$	Exposure delay after Interval start
Exposure Stop	$\mu s$	Exposure Stop related to Interval Start
Strobe Start	$\mu s$	Strobe delay after Interval start
Strobe Stop	$\mu s$	Strobe Stop related to Interval Start
PWM Frequency	T	Basic duty cycle ( 1 / Hz ) for PWM
PWM Line 1	%	Demodulation Result
PWM Line 2	%	Demodulation Result
PWM Line 3	%	Demodulation Result
PWM Line 4	%	Demodulation Result

**Values can be set for every scenario/interval**

When setting "Exposure Start" and "Stop" consider 'read-out-time'. It has to be within the Sequencer Interval.

- > Trigger Input can be set with the 4IO feature set
- > For physical trigger input refer to pinout or [specifications](#)
- > After trigger signal all programmed Interval will start.
- > Up to 16 Intervals can be programmed.

Sequencer settings can be saved to EPROM or to desktop

**Example:**

Values to set	Interval 0	Interval 1	Interval 2
Sequencer Interval	1.000.000 $\mu\text{s}$ (1s)	1.000.000 $\mu\text{s}$ (1s)	1.000.000 $\mu\text{s}$ (1s)
Exposure Start	220.000 $\mu\text{s}$	875.000 $\mu\text{s}$	190.000 $\mu\text{s}$
Exposure Stop	700.000 $\mu\text{s}$	125.000 $\mu\text{s}$	720.000 $\mu\text{s}$
Strobe Start	110.000 $\mu\text{s}$	125.000 $\mu\text{s}$	350.000 $\mu\text{s}$
Strobe Stop	875.000 $\mu\text{s}$	875.000 $\mu\text{s}$	875.000 $\mu\text{s}$
PWM			
Frequency	4 Hz	4 Hz	4 Hz
PWM Line 0	100	0	80
PWM Line 1	20	50	0
PWM Line 2	0	100	30
PWM Line 3	-	-	-
Trigger set to negative slope		Use higher frequencies	

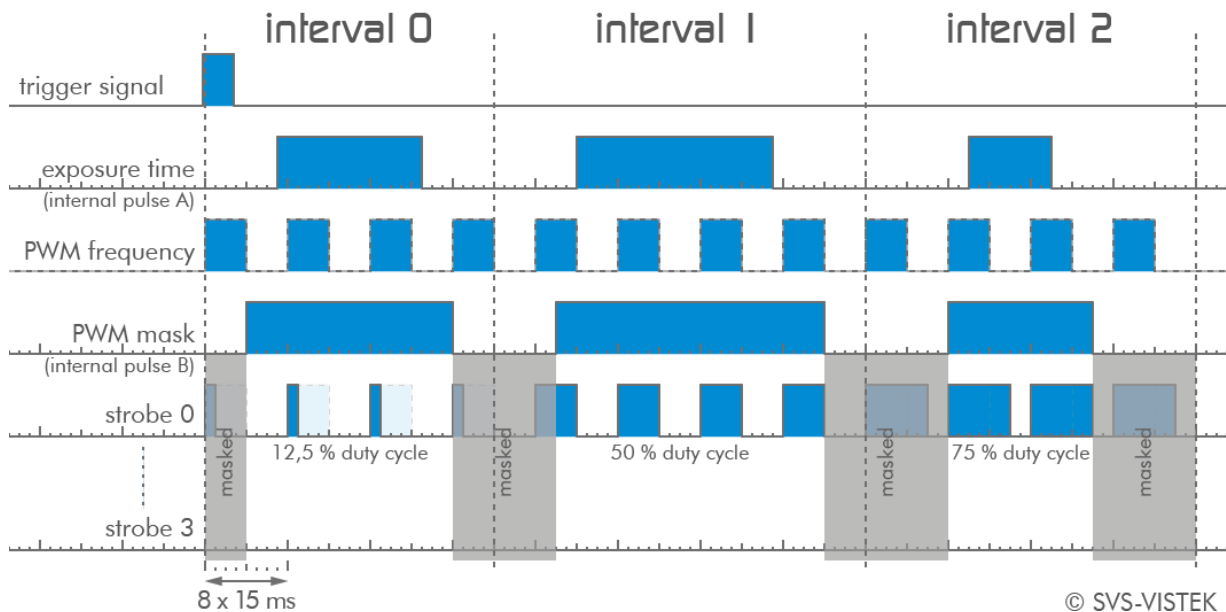

Figure 43: illustration of three sequencer intervals

### 7.3.4 PWM

Pulse width modulation

Description of the function used within the sequencer or implemented by the pulseloop module

During Pulse Width Modulation, a duty cycle is modulated by a fixed frequency square wave. This describes the ratio of ON to OFF as duty factor or duty ratio.

#### Why PWM?

Many electrical components must be provided with a defined voltage. Whether it's because they do not work otherwise or because they have the best performance at a certain voltage range (such as diodes or LEDs).

#### Diode characteristic

Since LEDs have a bounded workspace, the PWM ensures a variable intensity of illumination at a constant voltage on the diodes.

In addition, the lifetime of a diode increases. The internal resistance is ideal in this area. The diode gets time to cool down when operated with a PWM in its workspace.

#### Implementation of PWM

Modulation frequency:

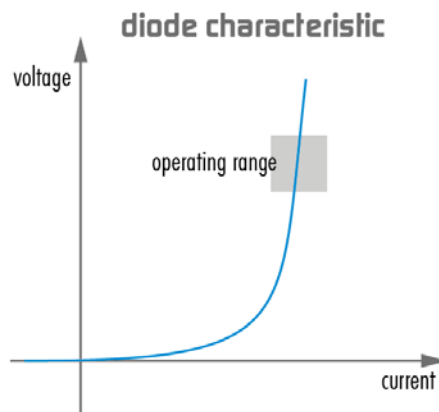

The basic frequency of the modulation is defined by the cycle duration "T".

$$T_{PWM} = \frac{1}{f_{PWM}}$$

Cycle duration "T" is written into the registry by multiple of the inverse of camera frequency. (15 ns steps) Refer to: [Time unit of the camera](#).

$$\begin{aligned} T_{PWM} &= \frac{1}{66,6MHz} \cdot PWMMax[SeqSelector] \\ &= 15 \text{ ns} \\ &\quad \cdot PWMMax[SeqSelector] \end{aligned}$$

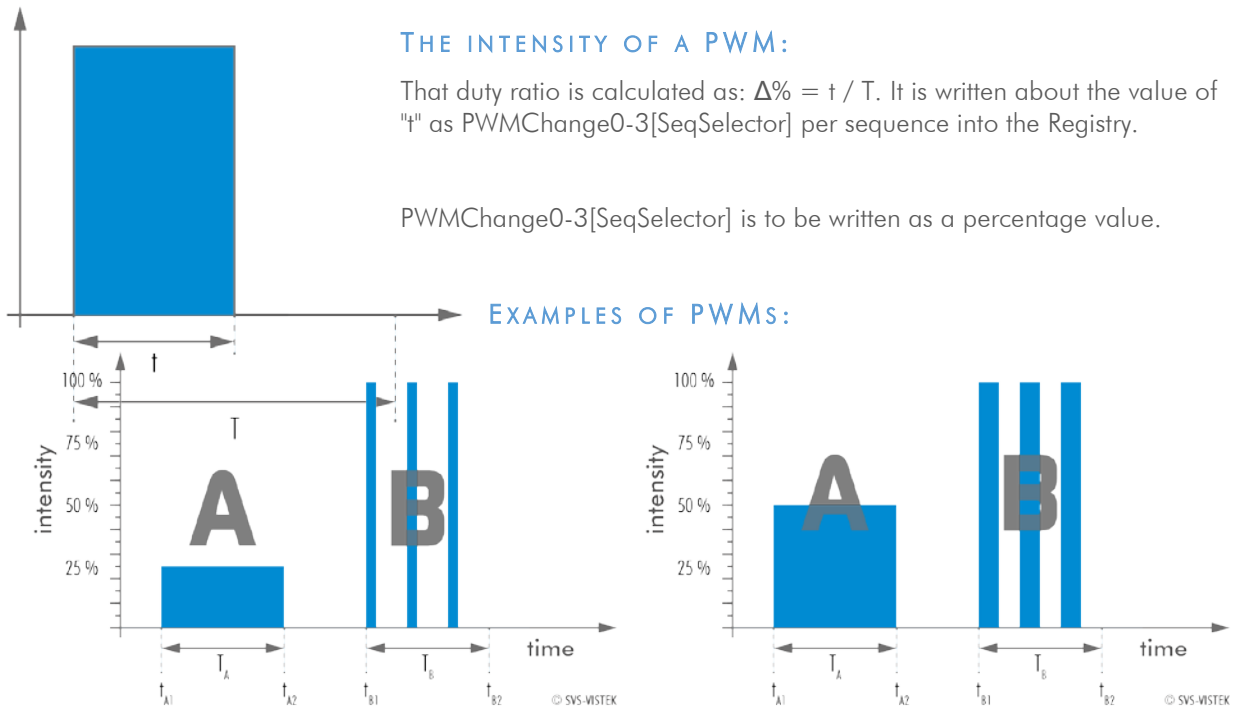

Figure 44: 25 % intensity

Figure 45: 50 % intensity

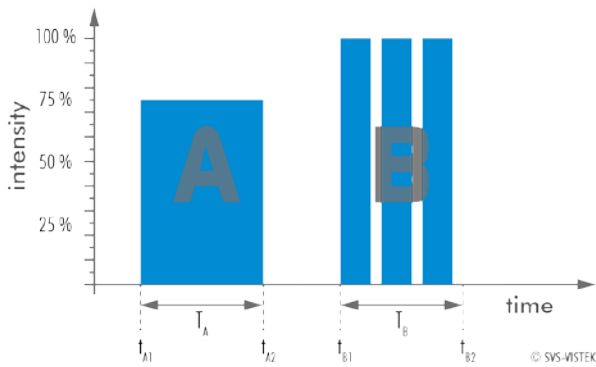

Figure 46: 75 % intensity

The integrals over both periods  $T_A$  and  $T_B$  are equal.

$$\int_{t_{A1}}^{t_{A2}} A = \int_{t_{B1}}^{t_{B2}} B$$

An equal amount of Photons will be emitted. The intensity of light is the same.

$$t_{A2} - t_{A1} = t_{B2} - t_{B1}$$

The periods  $T_A$  and  $T_B$  are equal in length.

**THE PWM MODULE:**

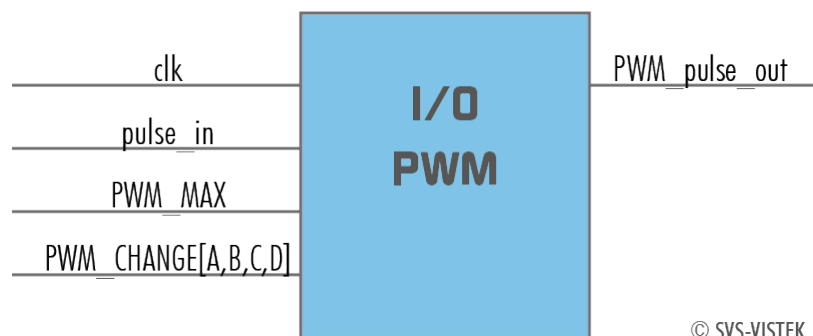

© SVS-VISTEK

**7.3.5 Optical Input**

An optical input is designed for galvanic separation of camera and triggering device. Noise, transients and voltage spikes might damage your components. Also trigger signal interpretation can be difficult with unclear voltage potentials within a system. The benefit of an optical input is to avoid all

these kinds of interaction from power sources or switches. The disadvantage of an optical input is that it is slower in terms of signal transmission than a direct electrical connection.

An optical input needs some current for operation. The SVS-Vistek optical input is specified to 5-24V, 8mA.

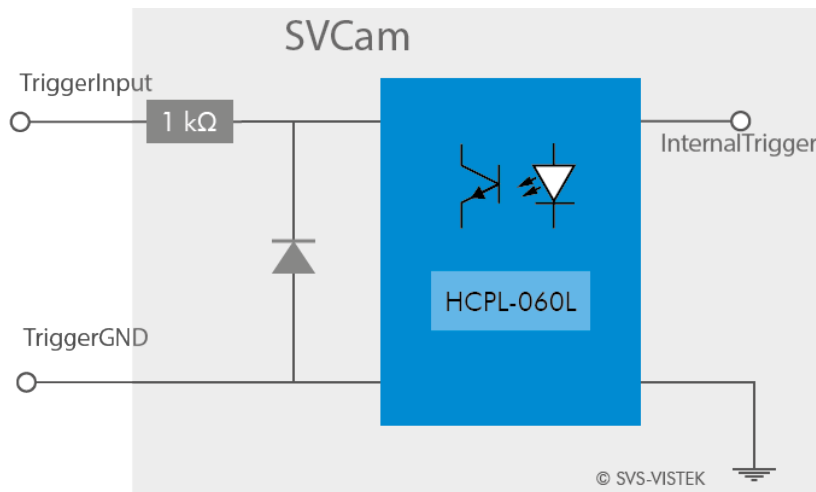

The opto coupler galvanically divides electrical circuits by emitting light on one side and interpreting light in the other. There is no direct electric interaction between both electrical circuits.

Figure 4 Optical input schematics

### 7.3.6 PLC/Logical Operation on Inputs

The logic input combines trigger signals with Boolean algorithms. The camera provides AND, NAND, OR, NOR as below. You might connect 2 signals on the logic input. The result can be connected to a camera trigger signal or it may be source for the next logical operation with another input. It is possible to connect it to an OUT line as well.

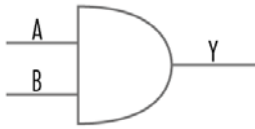

#### AND

Both trigger inputs have to be true.

A	B	$Y = A \wedge B$
0	0	0
0	1	0
1	0	0
1	1	1

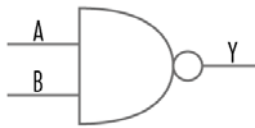
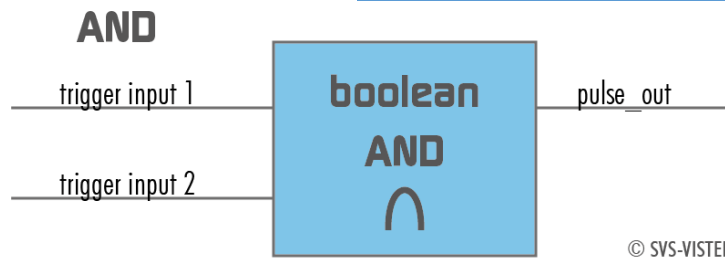

#### NAND

The **NEGATIVE-AND** is true only if its inputs are false.

Invert the output of the AND module.

A	B	$Y = A \text{ NAND } B$
0	0	1
0	1	1
1	0	1
1	1	0

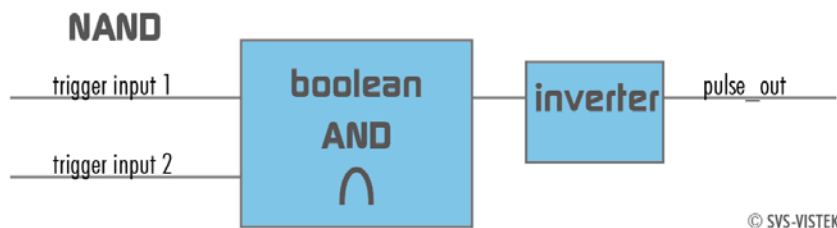



**OR**

If neither input is high, a low pulse\_out (0) results.

Combine trigger input one and two.

A	B	$Y = A \vee B$
0	0	0
0	1	1
1	0	1
1	1	1

**OR**



© SVS-VISTEK



**NOR**

No trigger input – one nor two – results in a high or a low level pulse\_out.

Invert both trigger inputs. By inverting the resulting pulse\_out you will get the NOR i pulse

A	B	$Y = A \bar{\vee} B$	NOR	$Y = A \vee B$	NOR i
0	0	1		0	
0	1	0		1	
1	0	0		1	
1	1	0		1	

**NOR**

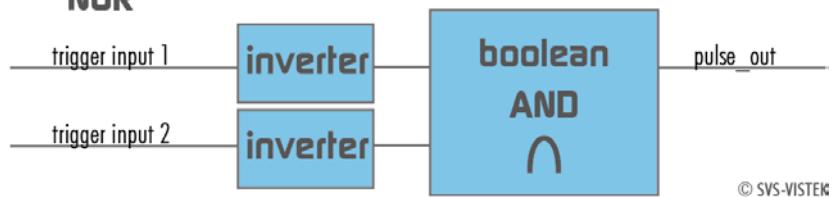

© SVS-VISTEK

**NOR i**

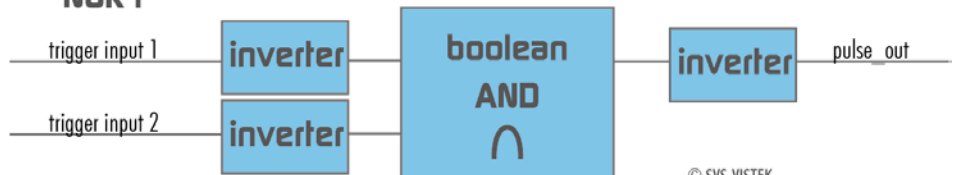

© SVS-VISTEK

**7.3.7 Serial data interfaces**

(ANSI EIA/) TIA-232-F

RS-232 and RS-422 (from EIA, read as Radio Sector or commonly as Recommended Standard) are technical standards to specify electrical characteristics of digital signaling circuits.



In the SVCam's these signals are used to send low-power data signals to control light or lenses (MFT).

Serial interface Parameter	RS-232	RS-422
Maximum open-circuit voltage	$\pm 25$ V	$\pm 6$ V
Max Differential Voltage	25 V	10 V
Min. Signal Range	$\pm 3$ V	2 V
Max. Signal Range	$\pm 15$ V	10 V

Table 2: serial interface parameter – RS-232 and RS-422

### RS-232

It is splitted into 2 lines receiving and transferring Data.

RXD     receive data  
TXD     transmit data

Signal voltage values are:

low:    -3 ... -15 V

high:   +3 ... +15 V

With restrictions: refer to Table: serial interface parameter above.

Data transport is asynchronous. Synchronization is implemented by first and last bit of a package. Therefore the last bit can be longer, e.g. 1.5 or 2 times the bit duration). Data rate (bits per second) must be defined before transmission.

## UART

Packaging Data into containers (adding start and stop bits) is implemented by the UART (Universal Asynchronous Receiver Transmitter)

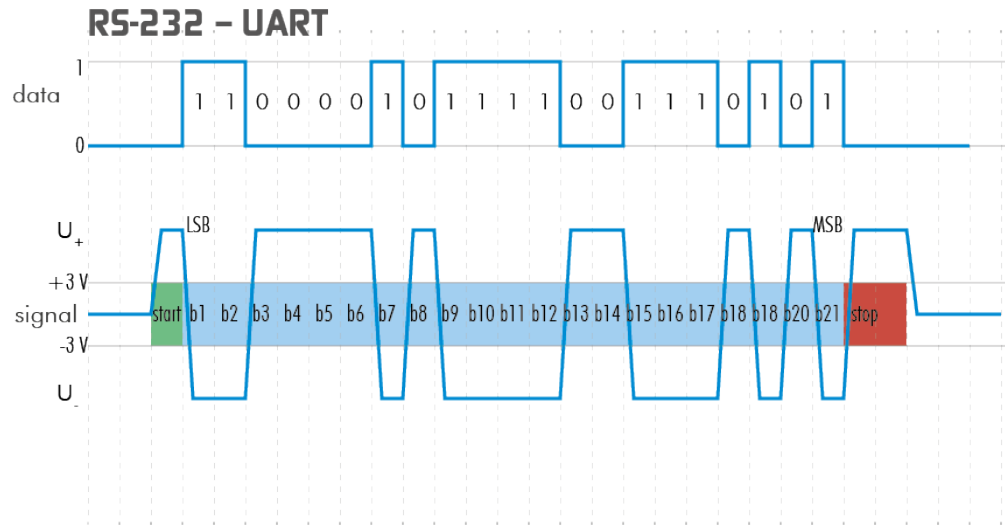

Figure 47: UART encoding of a data stream

## RS-422

RS-422 is a differential low voltage communication standard.

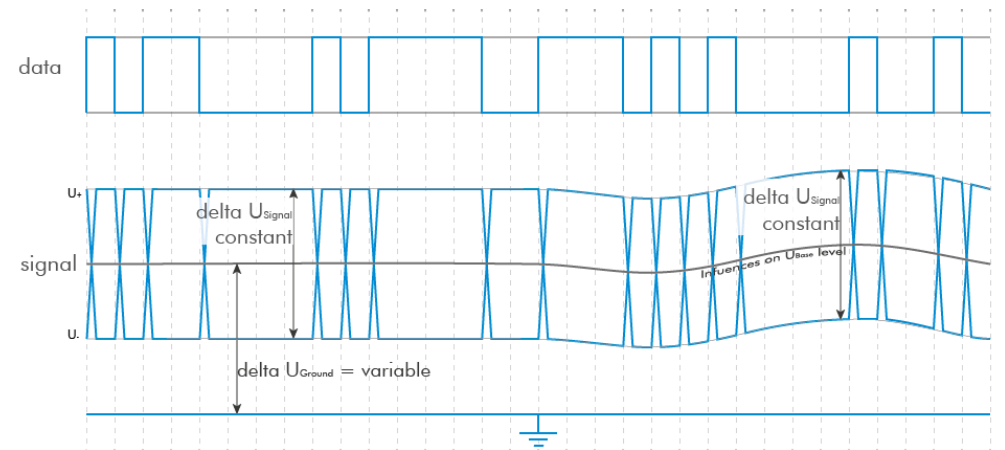

Figure 48: LVDS signal – no return to zero volt

Refer to [specifications](#) to see if RS-422 is implemented in your camera.

### 7.3.8 Trigger-Edge Sensitivity

Trigger-Edge Sensitivity is implemented by a “schmitt trigger”. Instead of triggering to a certain value Schmitt trigger provides a threshold.

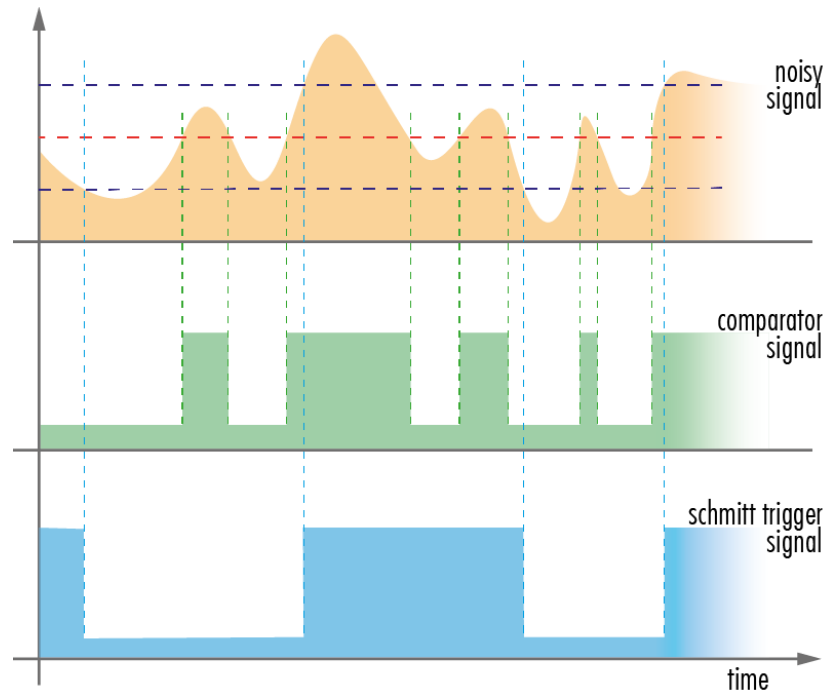

Figure 49: illustration of schmitt trigger noise suspension - high to low | low to high

### 7.3.9 Debouncing Trigger Signals

Bounces or glitches caused by a switch can be avoided by software within the SVCam.

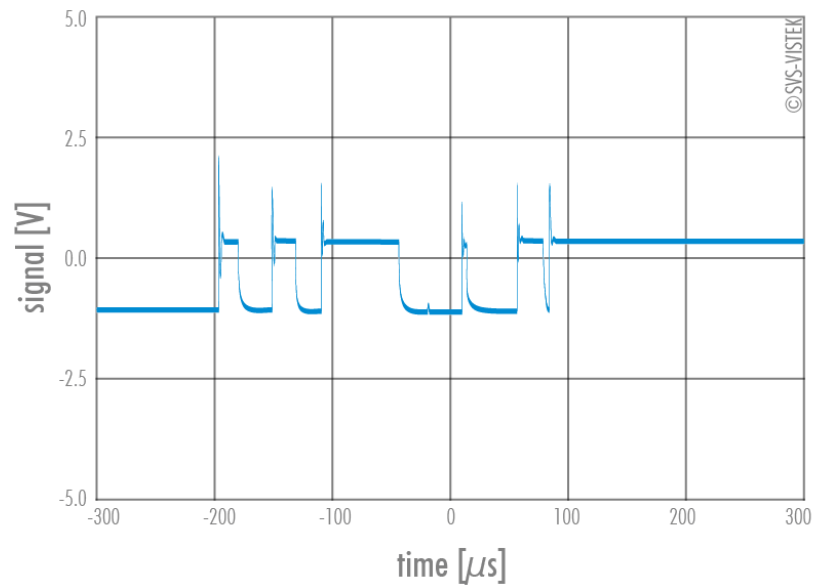

Figure 50: bounces or glitches caused by a switch during 300  $\mu$ s

Therefore the signal will not be accepted till it lasts at least a certain time.

Use the IO Assignment tool to place and enable the debouncer module in between the "trigger" (schmitt trigger) and the input source (e.g.: line 1).

DebounceDuration register can be set in multiples of 15ns (implement of system clock). E.g.  $66\ 666 \approx 1\ \text{ms}$

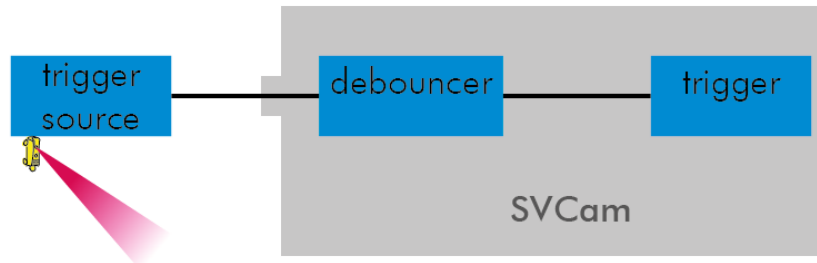
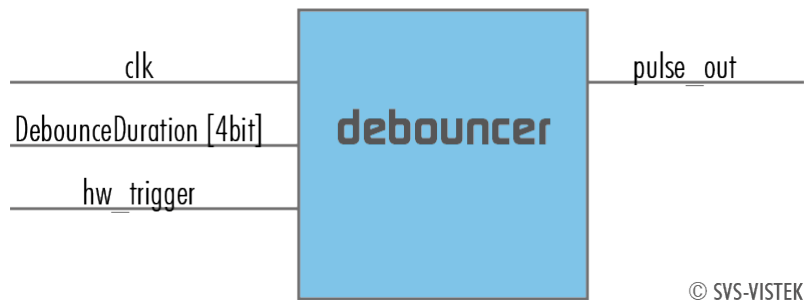

Figure 51: block diagram – debouncer in between the trigger source and the trigger

### The Debouncer module



© SVS-VISTEK

Figure 52: Illustration of the debouncer module

### 7.3.10 Prescale

The Prescaler function can be used for masking off input pulses by applying a divisor with a 4-bit word, resulting in 16 unique settings.

- > Reducing count of interpreted trigger signal
- > Use the prescaler to ignore a certain count of trigger signals.
- > Divide the amount of trigger signals by setting a divisor.
- > Maximum value for prescale divisor: is 16 (4 bit)

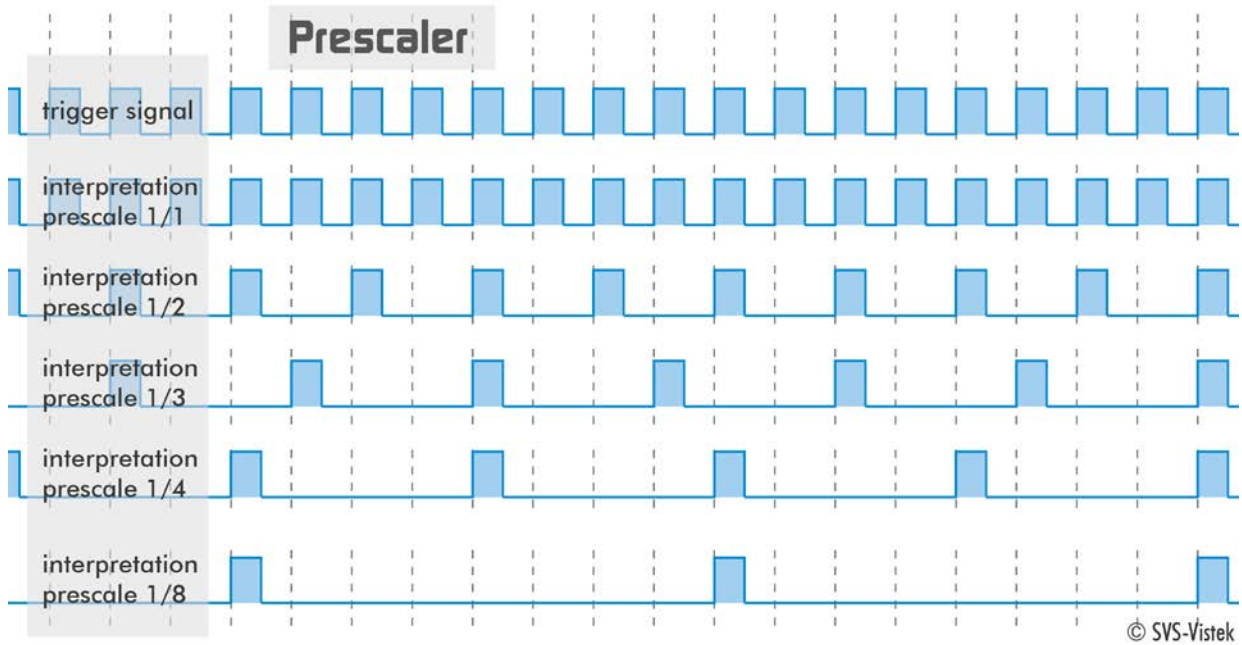

Figure 53: illustration of prescale values

### The prescale module

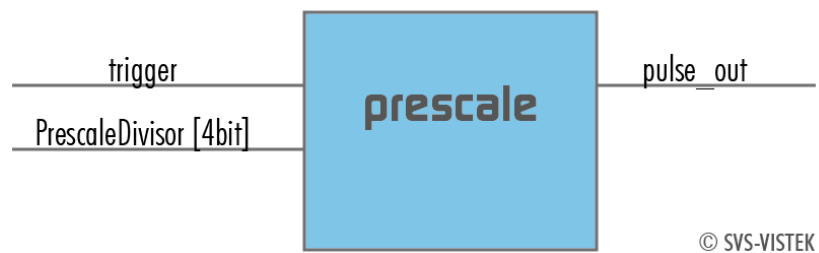

Figure 54: Illustration of the prescale module

### 7.3.11 IR Cut Filter

- > The EXO monochrome comes by default with an AR-Filter (anti reflex)
- > The EXO color version comes by default with an IR-cut-filter

To avoid influences of infrared light to your image, cameras are equipped with an IR cut filter or an anti-reflection coated glass (AR filter).

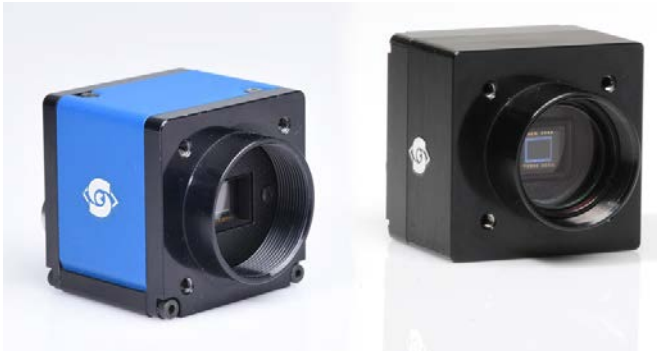
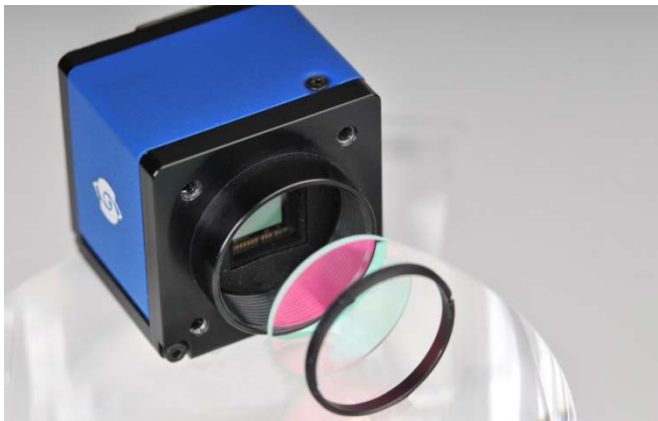

Figure 55: ECO standard & ECO Blackline with IR cut filter

In addition filters raise the protection class of the camera by protecting the sensor and camera internals from environmental influences. IP67 models do have an IR cut filter by default.

Please refer to your camera order to see if a filter is built in. Alternatively take a close look on the sensor. Build-in IR-filters are screwed within the lens mount. (See figure below)



All kinds of filter can be ordered and placed in front of the sensors. Please refer to your local distributor.



#### NOTICE

As the sensor is very sensitive to smallest particles, avoid dust when removing the lens or the protection cap

## Image Impact of IR Cut Filter

As a reason of chromatic aberration limiting the spectral bandwidth of the light always results in sharper images.

Without an IR cut filter:

- > Monochrome sensor images get muddy.
- > Chroma sensor images get influenced by a greater amount of red than you would see with your eyes. White balance gets much more difficult. Contrasts get lost because of IR light influencing also blue and green pixels.

SVS-VISTEK recommends IR cut filter for high demands on color or sharpness whether monochrome or color sensors.

## Spectral Impact of IR Cut Filters

IR cut filter do influence the spectral sensitivity of the sensor. The spectral graph below shows the wavelength relative impact of the SVS-VISTEK standard filter.

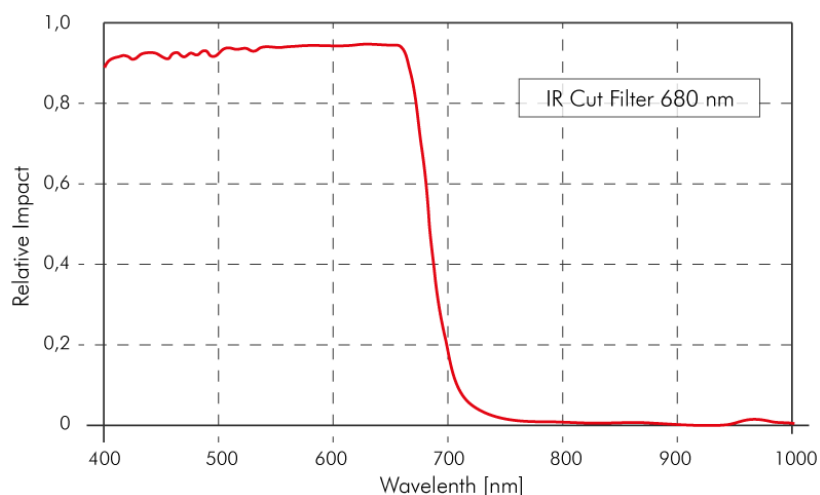

Figure 56: Diagram of light transmission – IR cut filter

## Focal Impact of Filters

As an IR cut filter mainly consist of a small layer of glass (1 mm thick) there is an impact on the flange focal distance. Refraction within the layer cause shortening this distance.

When ordering a standard camera with an extra IR cut filter you might have to compensate the focal length with an extra ring. Please refer to your local distributor for more detailed information on your camera behaving on C-Mount integrated filters.

As BlackLine models have an IR cut filter by default, the focal distance is compensated by default too.



### NOTICE

Removing the IR cut filter lengthen the focal distance and will invalidate the warranty of your camera.

---

## 8 Specifications

The following pages will give an overview of the core features of EXO Camera Link cameras.

Note: The EXO\*CL cameras are supporting 1x3\_1y tap configuration. If your framegrabber is supporting this as well, you might get framerates up to 50% higher than shown in the datasheet.



## 8.1 EXO174\*CL

<b>Model</b>	<b>exo174MCL</b>	<b>exo174CCL</b>
family	EXO	EXO
active pixel w x h	1920 x 1200	1920 x 1200
max. frame rate	70 fps	70 fps
chroma	mono	color
interface	Camera Link Base	Camera Link Base
sensor name	IMX174LLJ	IMX174LQJ
sensor manufacturer	Sony	Sony
sensor architecture	Area CMOS	Area CMOS
shutter type	global	global
equivalent format	1/1.2"	1/1.2"
diagonal	13,4 mm	13,4 mm
pixel w x h	5,86x5,86 $\mu\text{m}$	5,86x5,86 $\mu\text{m}$
optic sensor w x h	11,34x7,13 mm	11,34x7,13 mm
exposure time	20 $\mu\text{s}$ / 1s	20 $\mu\text{s}$ / 1s
max. gain	18 dB	18 dB
dynamic range	72 dB	72 dB
S/N Ratio	44	44
frame buffer	256 MB	256 MB
CL_geometry	1x2-1y;1x3-1y	1x2-1y;1x3-1y
frequency select	-	-
camera pixel clock	50 MHz	50 MHz
exp. time adjustment	manual;auto;external	manual;auto;external
px format 8 / 12 / 16	x / x / -	x / x / -
packed readout	-	-
max binning h / v	2 / 2	2 / 2
LUT	12to8(1)	12to8(1)
ROI	1	1
white balancing	-	auto;manual
tap balancing	-	-
gain	auto;manual	auto;manual
black level	manual	manual
PIV mode	-	-
readout control	-	-
flat field correction	-	-
shading correction	-	-
defect pixel correction	-	-
image flip	horizontal;vertical	horizontal;vertical

trigger modes	internal;software;external	internal;software;external
trigger edge high / low	x / x	x / x
sequencer	x	x
PWM power out	x	x
trigger IN TTL-24 V	2	2
outputs open drain	4	4
optical in / out	1 / -	1 / -
RS-232 in / out	1 / 1	1 / 1
RS-422 in / out	- / -	- / -
power supply	10...25 V	10...25 V

lens mount	C-Mount	C-Mount
dynamic lens control	-	-
size w / h / d (1)	50x50x33,89 mm	50x50x33,89 mm
weight	138 g	138 g
protection class	IP40	IP40
power consumption	4,0 W	4,0 W
ambient temperature		
housing temperature	-10... 60°C	-10... 60°C
status	production	production

(1) please refer to model drawings

© SVS-VISTEK

February 22, 2017

February 22, 2017

## Spectral sensitivity characteristics

*Color*

Figure 57: IMX174LQJ

*Mono*

Figure 58: IMX174LLJ

## 8.2 EXO249\*CL

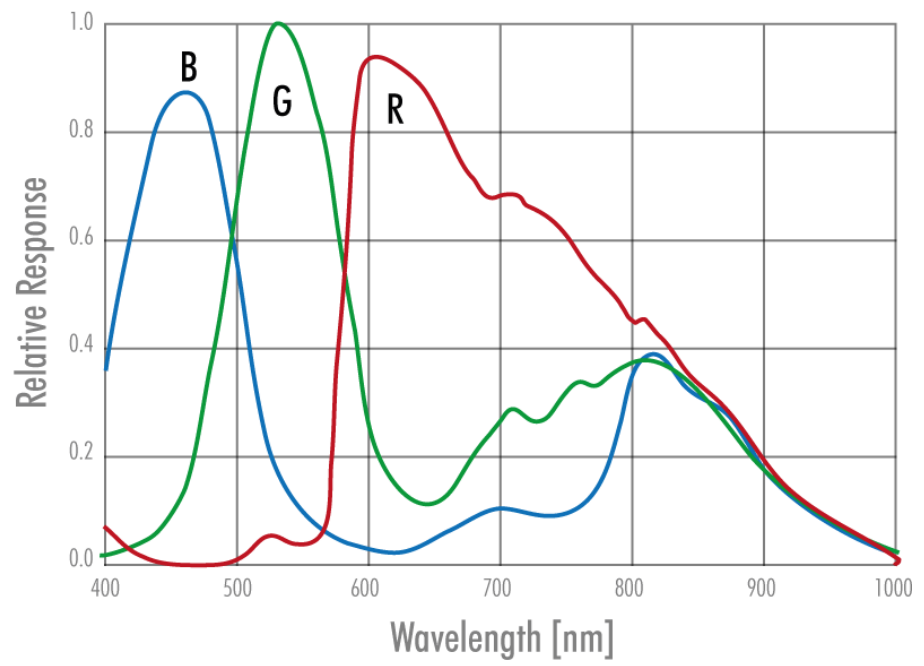
Model	exo249CCL	exo249MCL
family	EXO	EXO
active pixel w x h	1920 x 1200	1920 x 1200
max. frame rate	31 fps	31 fps
chroma	color	mono
interface	Camera Link Base	Camera Link Base
sensor name	IMX249LQJ	IMX249LLJ
sensor manufacturer	Sony	Sony
sensor architecture	Area CMOS	Area CMOS
shutter type	global	global
equivalent format	1/1.2"	1/1.2"
diagonal	13,4 mm	13,4 mm
pixel w x h	5,86x5,86 $\mu\text{m}$	5,86x5,86 $\mu\text{m}$
optic sensor w x h	11,34x7,13 mm	11,34x7,13 mm
exposure time	38 $\mu\text{s}$ / 1s	38 $\mu\text{s}$ / 1s
max. gain	18 dB	18 dB
dynamic range	72 dB	72 dB
S/N Ratio	44	44
frame buffer	256 MB	256 MB
CL_geometry	1x2-1y;1x3-1y	1x2-1y;1x3-1y
frequency select	-	-
camera pixel clock	50 MHz	50 MHz
exp. time adjustment	manual;auto;external	manual;auto;external
px format 8 / 12 / 16	x / x / -	x / x / -
packed readout	-	-
max binning h / v	2 / 2	2 / 2
LUT	12to8(1)	12to8(1)
ROI	1	1
white balancing	-	auto;manual
tap balancing	-	-
gain	auto;manual	auto;manual
black level	manual	manual
PIV mode	-	-
readout control	-	-
flat field correction	-	-
shading correction	-	-
defect pixel correction	-	-
image flip	horizontal;vertical	horizontal;vertical

trigger modes	internal;software;external	internal;software;external
trigger edge high / low	x / x	x / x
sequencer	x	x
PWM power out	x	x
trigger IN TTL-24 V	2	2
outputs open drain	4	4
optical in / out	1 / -	1 / -
RS-232 in / out	1 / 1	1 / 1
RS-422 in / out	- / -	- / -
power supply	10...25 V	10...25 V

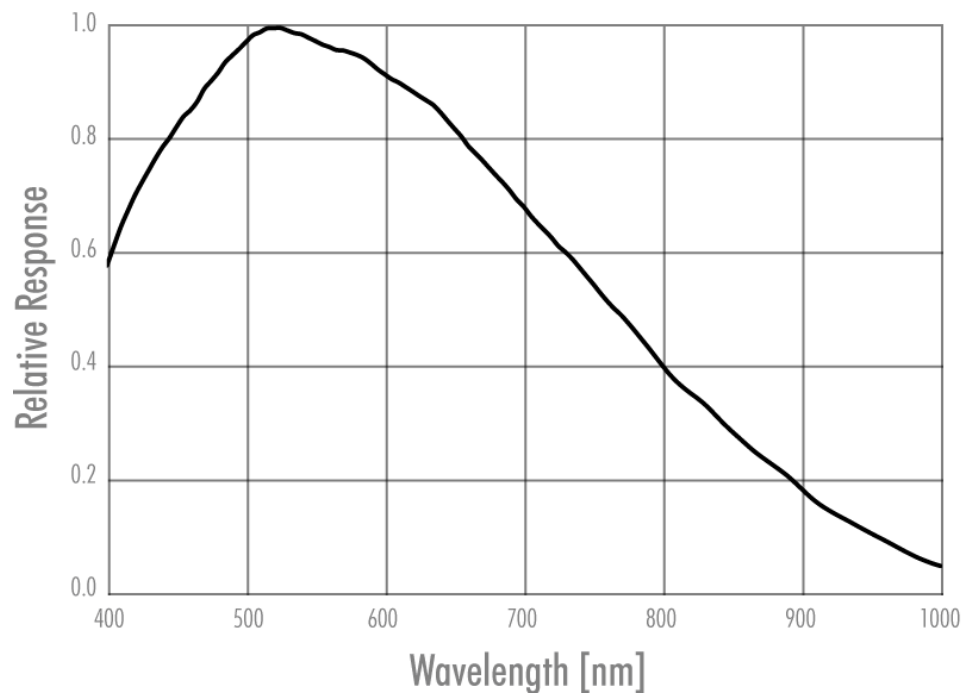
lens mount	C-Mount	C-Mount
dynamic lens control	-	-
size w / h / d (1)	50x50x33,89 mm	50x50x33,89 mm
weight	138 g	138 g
protection class	IP40	IP40
power consumption	4,0 W	4,0 W
ambient temperature	-10...45°C	-10...45°C
housing temperature		
status	replaced	replaced

(1) please refer to model drawings

© SVS-VISTEK

February 22, 2017

February 22, 2017

## Spectral sensitivity characteristics

*Color*

Figure 59: IMX249LQJ

*Mono*

Figure 60: IMX249LLJ

### 8.3 EXO250\*CL

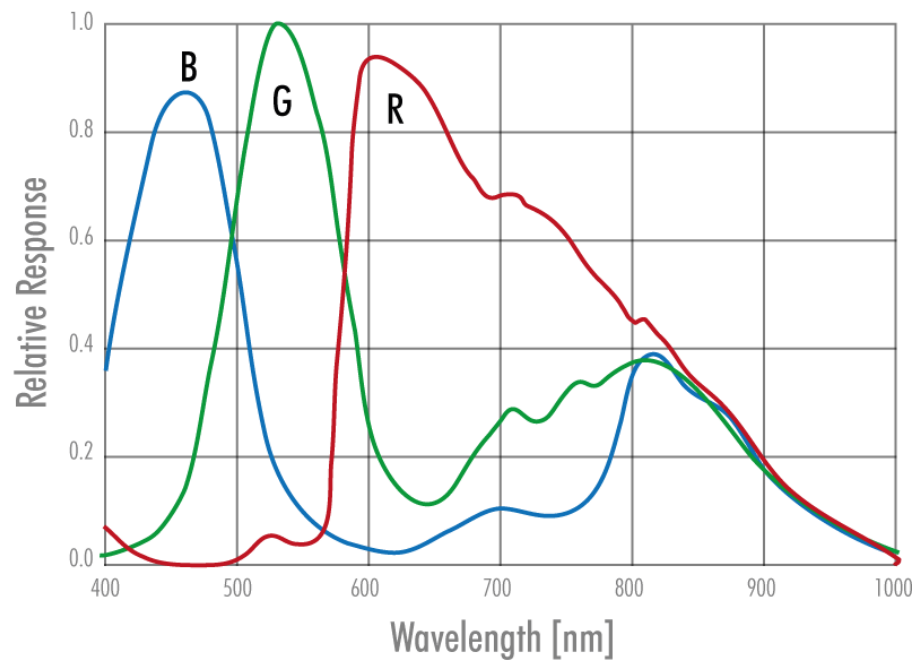
Model	exo250MCL	exo250CCL
family	EXO	EXO
active pixel w x h	2448 x 2048	2448 x 2048
max. frame rate	32 fps	32 fps
chroma	mono	color
interface	Camera Link Base	Camera Link Base
sensor name	IMX250LLR	IMX250LQR
sensor manufacturer	Sony	Sony
sensor architecture	Area CMOS	Area CMOS
shutter type	global	global
equivalent format	2/3"	2/3"
diagonal	11,1 mm	11,1 mm
pixel w x h	3,45x3,45 $\mu\text{m}$	3,45x3,45 $\mu\text{m}$
optic sensor w x h	8,5x7,09 mm	8,5x7,09 mm
exposure time	20 $\mu\text{s}$ / 1s	20 $\mu\text{s}$ / 1s
max. gain	18 dB	18 dB
dynamic range	72 dB	72 dB
S/N Ratio	40	40
frame buffer	256 MB	256 MB
CL_geometry	1x2-1y;1x3-1y	1x2-1y;1x3-1y
frequency select	-	-
camera pixel clock	50 MHz	50 MHz
exp. time adjustment	manual;auto;external	manual;auto;external
px format 8 / 12 / 16	x / x / -	x / x / -
packed readout	-	-
max binning h / v	2 / 2	2 / 2
LUT	12to8(1)	12to8(1)
ROI	1	1
white balancing	-	auto;manual
tap balancing	-	-
gain	auto;manual	auto;manual
black level	manual	manual
PIV mode	-	-
readout control	-	-
flat field correction	-	-
shading correction	-	-
defect pixel correction	-	-
image flip	horizontal;vertical	horizontal;vertical

trigger modes	internal;software;external	internal;software;external
trigger edge high / low	x / x	x / x
sequencer	x	x
PWM power out	x	x
trigger IN TTL-24 V	2	2
outputs open drain	4	4
optical in / out	1 / -	1 / -
RS-232 in / out	1 / 1	1 / 1
RS-422 in / out	- / -	- / -
power supply	10...25 V	10...25 V

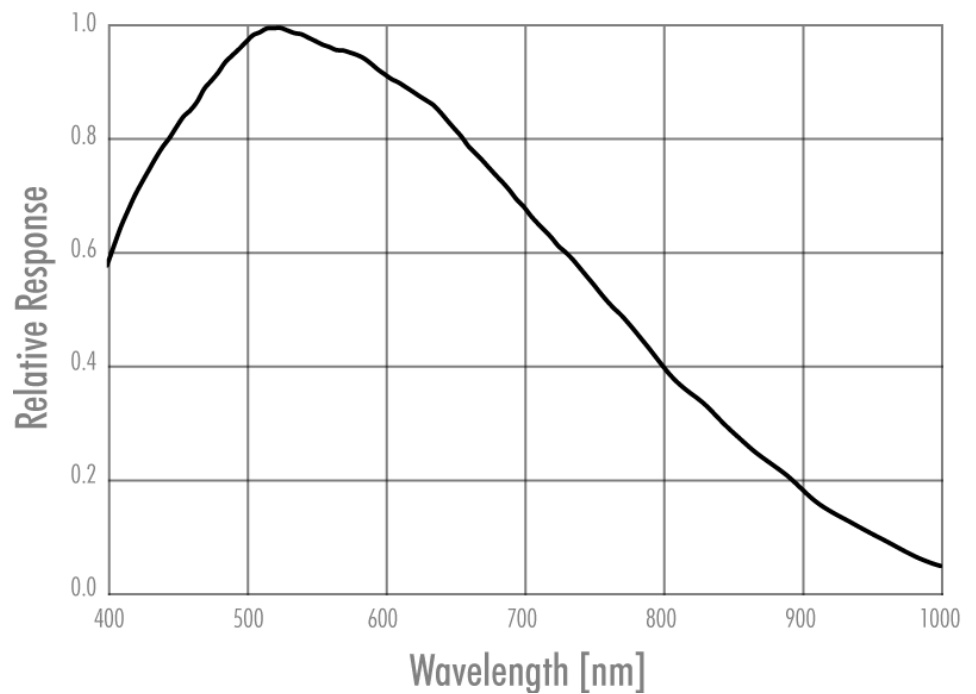
lens mount	C-Mount	C-Mount
dynamic lens control	-	-
size w / h / d (1)	50x50x34,12 mm	50x50x34,12 mm
weight	138 g	138 g
protection class	IP40	IP40
power consumption	4,0 W	4,0 W
ambient temperature		
housing temperature	-10... 60°C	-10... 60°C
status	production	production

(1) please refer to model drawings

© SVS-VISTEK

February 22, 2017

February 22, 2017

## Spectral sensitivity characteristics



*Color*

Figure 61: IMX250LQJR

*Mono*

Figure 62: IMX250LLR

## 8.4 EXO267\*CL

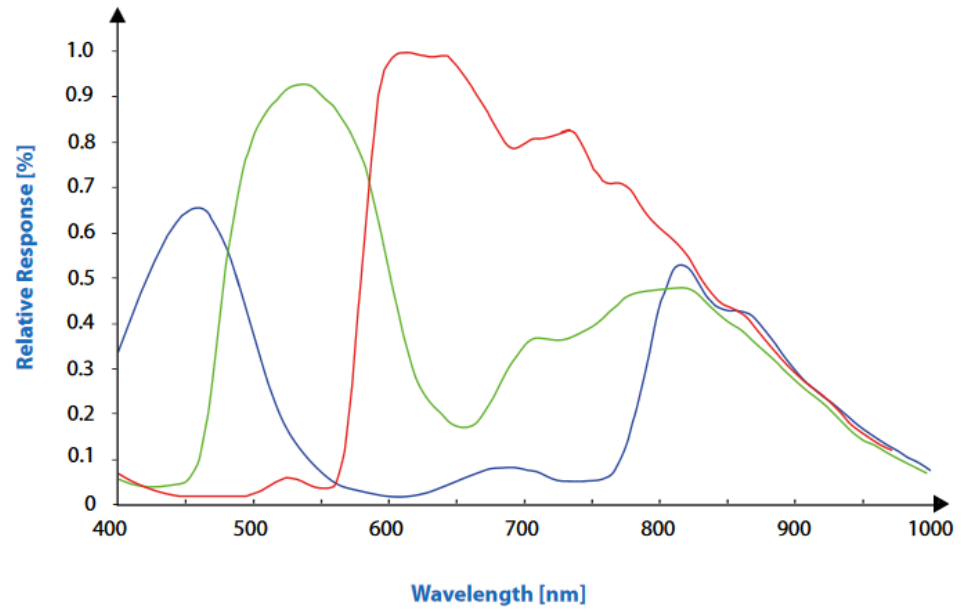
Model	exo267MCL	exo267CCL
family	EXO	EXO
active pixel w x h	4096 x 2160	4096 x 2160
max. frame rate	18 fps	18 fps
chroma	mono	color
interface	Camera Link Base	Camera Link Base
sensor name	IMX267LLR	IMX267LQR
sensor manufacturer	Sony	Sony
sensor architecture	Area CMOS	Area CMOS
shutter type	global	global
equivalent format	1"	1"
diagonal	16,0 mm	16,0 mm
pixel w x h	3,45x3,45 $\mu\text{m}$	3,45x3,45 $\mu\text{m}$
optic sensor w x h	8,5x7,09 mm	8,5x7,09 mm
exposure time	29 $\mu\text{s}$ / 1s	29 $\mu\text{s}$ / 1s
max. gain	18 dB	18 dB
dynamic range	72 dB	72 dB
S/N Ratio	39	39
frame buffer	256 MB	256 MB
CL_geometry	1x2-1y;1x3-1y	1x2-1y;1x3-1y
frequency select	-	-
camera pixel clock	50 MHz	50 MHz
exp. time adjustment	manual;auto;external	manual;auto;external
px format 8 / 12 / 16	x / x / -	x / x / -
packed readout	-	-
max binning h / v	2 / 2	2 / 2
LUT	12to12(1)	12to12(1)
ROI	-	-
white balancing	-	-
tap balancing	-	-
gain	auto;manual	auto;manual
black level	manual	manual
PIV mode	-	-
readout control	-	-
flat field correction	x	x
shading correction	external	external
defect pixel correction	true	true
image flip	horizontal;vertical	horizontal;vertical

trigger modes	internal;software;external	internal;software;external
trigger edge high / low	x / x	x / x
sequencer	x	x
PWM power out	x	x
trigger IN TTL-24 V	2	2
outputs open drain	4	4
optical in / out	1 / -	1 / -
RS-232 in / out	1 / 1	1 / 1
RS-422 in / out	- / -	- / -
power supply	10...25 V	10...25 V

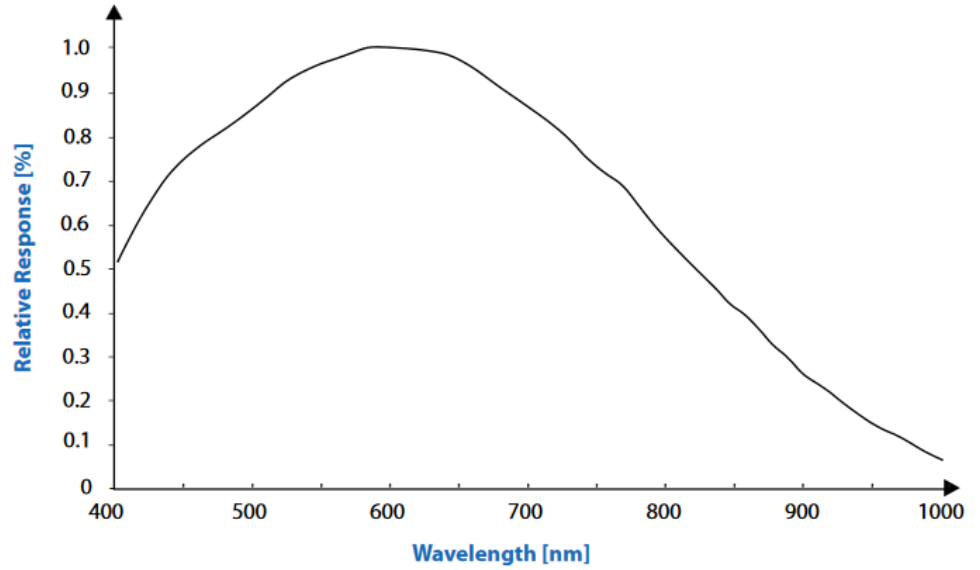
lens mount	C-Mount	C-Mount
dynamic lens control	-	-
size w / h / d (1)	50x50x34,12 mm	50x50x34,12 mm
weight	140 g	140 g
protection class	IP40	IP40
power consumption	4,0 W	4,0 W
ambient temperature		
housing temperature	-10... 60°C	-10... 60°C
status	production	production

(1) please refer to model drawings

© SVS-VISTEK

February 22, 2017

February 22, 2017

*Color*

**Spectral sensitivity characteristics**

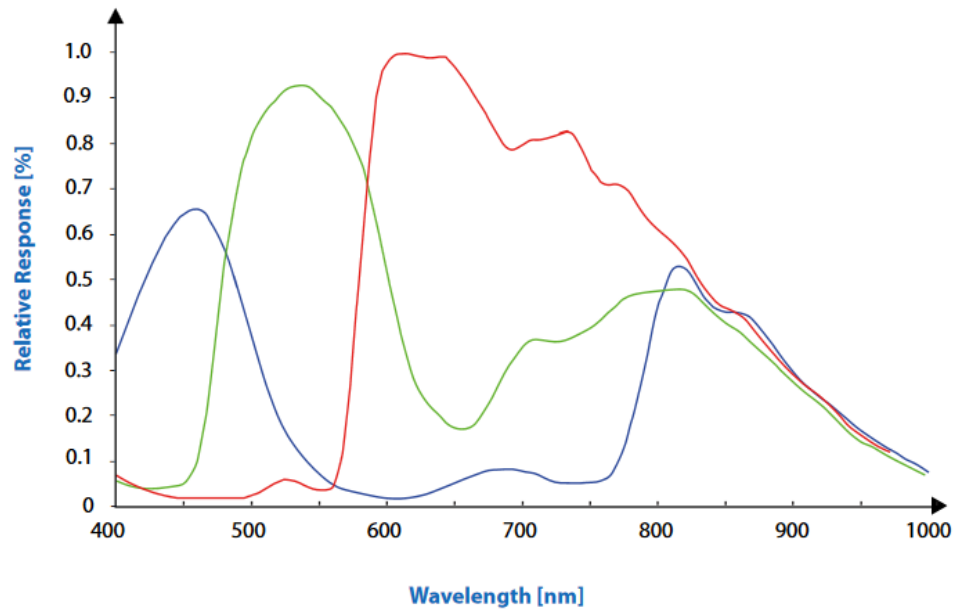

Figure 63: IMX267LQR

*Mono*

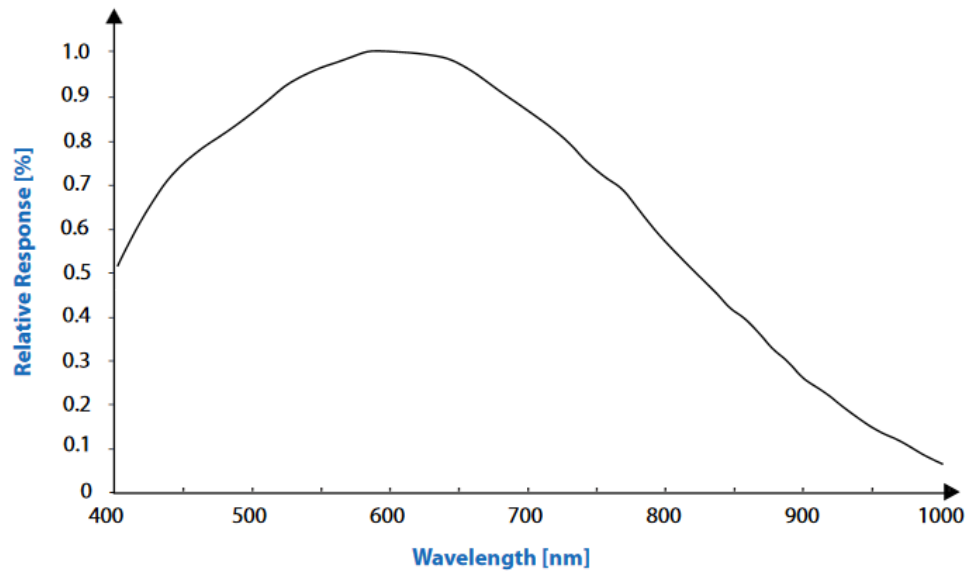

Figure 64: IMX267LLR

## 8.5 EXO304\*CL

Model	exo304MCL	exo304CCL
family	EXO	EXO
active pixel w x h	4096 x 3000	4096 x 3000
max. frame rate	13 fps	13 fps
chroma	mono	color
interface	Camera Link Base	Camera Link Base
sensor name	IMX304LLR	IMX304LQR
sensor manufacturer	Sony	Sony
sensor architecture	Area CMOS	Area CMOS
shutter type	global	global
equivalent format	1.1"	1.1"
diagonal	17,6 mm	17,6 mm
pixel w x h	3,45x3,45 $\mu\text{m}$	3,45x3,45 $\mu\text{m}$
optic sensor w x h	8,5x7,09 mm	8,5x7,09 mm
exposure time	29 $\mu\text{s}$ / 1s	29 $\mu\text{s}$ / 1s
max. gain	18 dB	18 dB
dynamic range	72 dB	72 dB
S/N Ratio	39.5	39.5
frame buffer	256 MB	256 MB
CL_geometry	1x2-1y;1x3-1y	1x2-1y;1x3-1y
frequency select	-	-
camera pixel clock	50 MHz	50 MHz
exp. time adjustment	manual;auto;external	manual;auto;external
px format 8 / 12 / 16	x / x / -	x / x / -
packed readout	-	-
max binning h / v	2 / 2	2 / 2
LUT	12to8(1)	12to8(1)
ROI	1	1
white balancing	-	auto;manual
tap balancing	-	-
gain	auto;manual	auto;manual
black level	manual	manual
PIV mode	-	-
readout control	-	-
flat field correction	-	-
shading correction	-	-
defect pixel correction	-	-
image flip	horizontal;vertical	horizontal;vertical

trigger modes	internal;software;external	internal;software;external
trigger edge high / low	x / x	x / x
sequencer	x	x
PWM power out	x	x
trigger IN TTL-24 V	2	2
outputs open drain	4	4
optical in / out	1 / -	1 / -
RS-232 in / out	1 / 1	1 / 1
RS-422 in / out	- / -	- / -
power supply	10...25 V	10...25 V

lens mount	C-Mount	C-Mount
dynamic lens control	-	-
size w / h / d (1)	50x50x34,12 mm	50x50x34,12 mm
weight	140 g	140 g
protection class	IP40	IP40
power consumption	4,0 W	4,0 W
ambient temperature		
housing temperature	-10... 60°C	-10... 60°C
status	production	production

(1) please refer to model drawings

© SVS-VISTEK

February 22, 2017

February 22, 2017

## Spectral sensitivity characteristics

*Color*

Figure 65: IMX304LQR

*Mono*

Figure 66: IMX304LLR

## 8.6 EXO4000\*CL

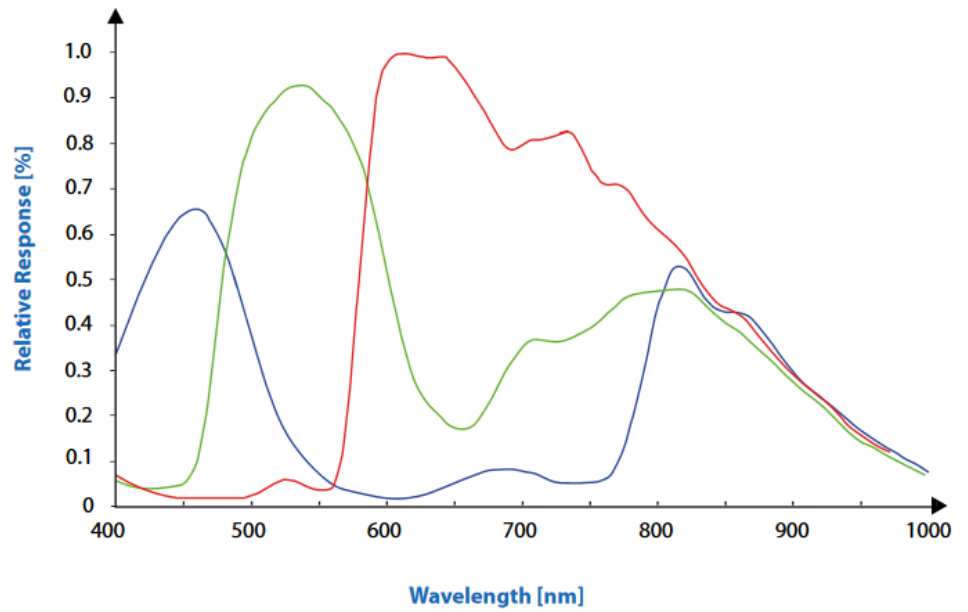
Model	exo4000MCL	exo4000CCL
family	EXO	EXO
active pixel w x h	2048 x 2048	2048 x 2048
max. frame rate	40 fps	40 fps
chroma	mono	color
interface	Camera Link Base	Camera Link Base
sensor name	CMV4000-3E5M1PP	CMV4000-3E5C1PP
sensor manufacturer	CMOSIS	CMOSIS
sensor architecture	Area CMOS	Area CMOS
shutter type	global	global
equivalent format	1"	1"
diagonal	15,9 mm	15,9 mm
pixel w x h	5,5x5,5 $\mu\text{m}$	5,5x5,5 $\mu\text{m}$
optic sensor w x h	11,26x11,26 mm	11,26x11,26 mm
exposure time	26 $\mu\text{s}$ / 1s	26 $\mu\text{s}$ / 1s
max. gain	18 dB	18 dB
dynamic range	52 dB	52 dB
S/N Ratio	38	38
frame buffer	256 MB	256 MB
CL_geometry	1x2-1y;1x3-1y	1x2-1y;1x3-1y
frequency select	-	-
camera pixel clock	50 MHz	50 MHz
exp. time adjustment	manual;auto;external	manual;auto;external
px format 8 / 12 / 16	x / x / -	x / x / -
packed readout	-	-
max binning h / v	2 / 2	2 / 2
LUT	12to8(1)	12to8(1)
ROI	1	1
white balancing	-	auto;manual
tap balancing	-	-
gain	auto;manual	auto;manual
black level	manual	manual
PIV mode	-	-
readout control	-	-
flat field correction	-	-
shading correction	-	-
defect pixel correction	-	-
image flip	horizontal;vertical	horizontal;vertical

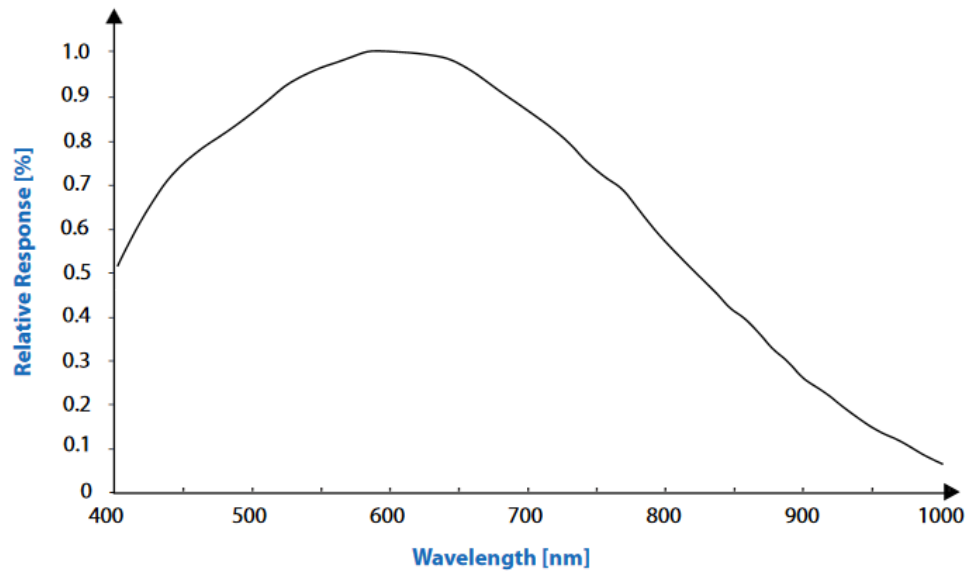

trigger modes	internal;software;external	internal;software;external
trigger edge high / low	x / x	x / x
sequencer	x	x
PWM power out	x	x
trigger IN TTL-24 V	2	2
outputs open drain	4	4
optical in / out	1 / -	1 / -
RS-232 in / out	1 / 1	1 / 1
RS-422 in / out	- / -	- / -
power supply	10...25 V	10...25 V

lens mount	C-Mount	C-Mount
dynamic lens control	-	-
size w / h / d (1)	50x50x38,04 mm	50x50x38,04 mm
weight	138 g	138 g
protection class	IP40	IP40
power consumption	4,5 W	4,5 W
ambient temperature	-10...45°C	-10...45°C
housing temperature		
status	production	production

(1) please refer to model drawings

© SVS-VISTEK

February 22, 2017

February 22, 2017

Color

Spectral sensitivity characteristics

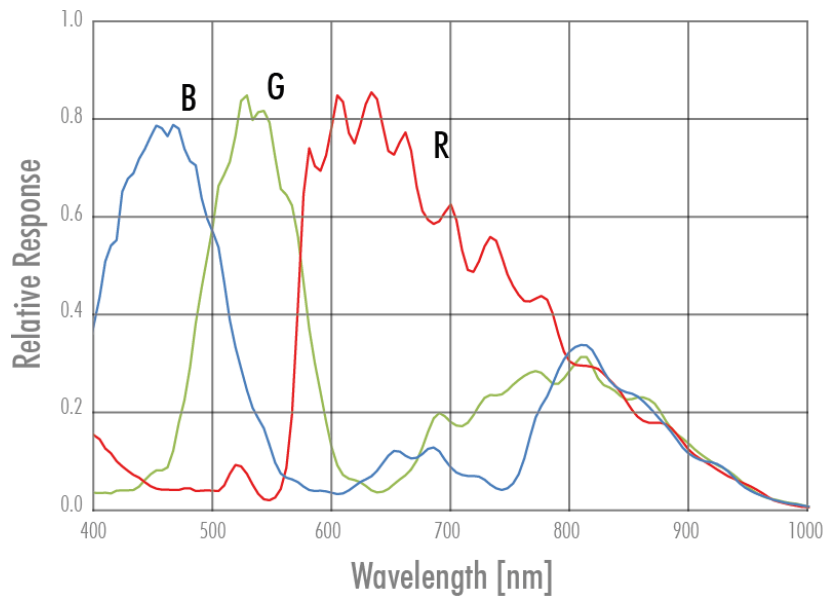

Figure 67: CMV4000-3E5C1PP

Mono

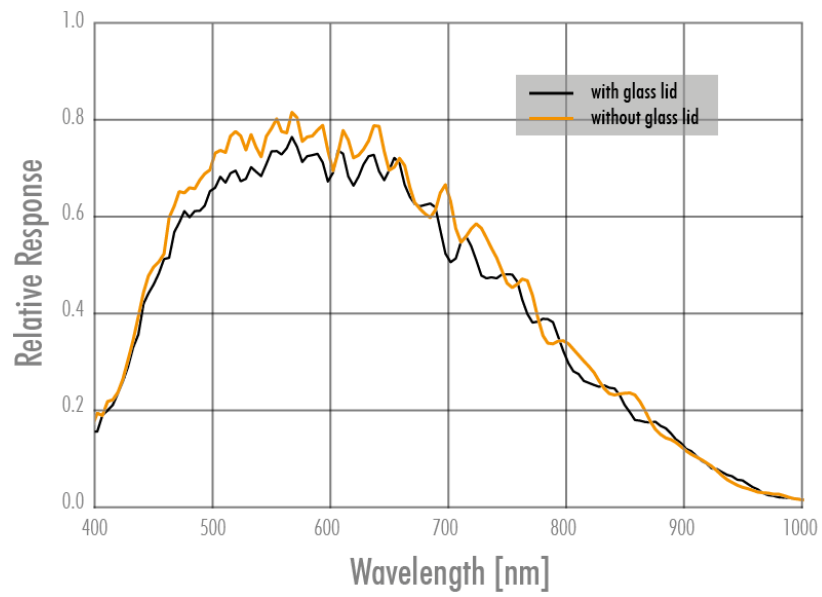

Figure 68: CMV4000-3E5M1PP

## 8.7 EXO5000\*CL

<b>Model</b>	<b>exo5000MCL</b>	<b>exo5000CCL</b>
family	EXO	EXO
active pixel w x h	2592 x 2048	2592 x 2048
max. frame rate	34 fps	34 fps
chroma	mono	color
interface	Camera Link Base	Camera Link Base
sensor name	NOIP1SN5000A	NOIP1SE5000A
sensor manufacturer	ON Semiconductor	ON Semiconductor
sensor architecture	Area CMOS	Area CMOS
shutter type	global	global
equivalent format	2/3"	2/3"
diagonal	11,4 mm	11,4 mm
pixel w x h	4,8x4,8 $\mu$ m	4,8x4,8 $\mu$ m
optic sensor w x h	8,94x7,06 mm	8,94x7,06 mm
exposure time	40 $\mu$ s / 1s	40 $\mu$ s / 1s
max. gain	18 dB	18 dB
dynamic range	58 dB	58 dB
S/N Ratio		
frame buffer	256 MB	256 MB
CL_geometry	1x2-1y;1x3-1y	1x2-1y;1x3-1y
frequency select	-	-
camera pixel clock	72 MHz	72 MHz
exp. time adjustment	manual;auto;external	manual;auto;external
px format 8 / 12 / 16	x / x / -	x / x / -
packed readout	-	-
max binning h / v	2 / 2	2 / 2
LUT	12to8(1)	12to8(1)
ROI	1	1
white balancing	-	auto;manual
tap balancing	-	-
gain	auto;manual	auto;manual
black level	manual	manual
PIV mode	-	-
readout control	-	-
flat field correction	-	-
shading correction	-	-
defect pixel correction	-	-
image flip	horizontal;vertical	horizontal;vertical

trigger modes	internal;software;external	internal;software;external
trigger edge high / low	x / x	x / x
sequencer	x	x
PWM power out	x	x
trigger IN TTL-24 V	2	2
outputs open drain	4	4
optical in / out	1 / -	1 / -
RS-232 in / out	1 / 1	1 / 1
RS-422 in / out	- / -	- / -
power supply	10...25 V	10...25 V

lens mount	C-Mount	C-Mount
dynamic lens control	-	-
size w / h / d (1)	50x50x34,13 mm	50x50x34,13 mm
weight	138 g	138 g
protection class	IP40	IP40
power consumption	4,5 W	4,5 W
ambient temperature	-10...45°C	-10...45°C
housing temperature		
status	production	production

(1) please refer to model drawings

© SVS-VISTEK

February 22, 2017

February 22, 2017

Color

Spectral sensitivity characteristics

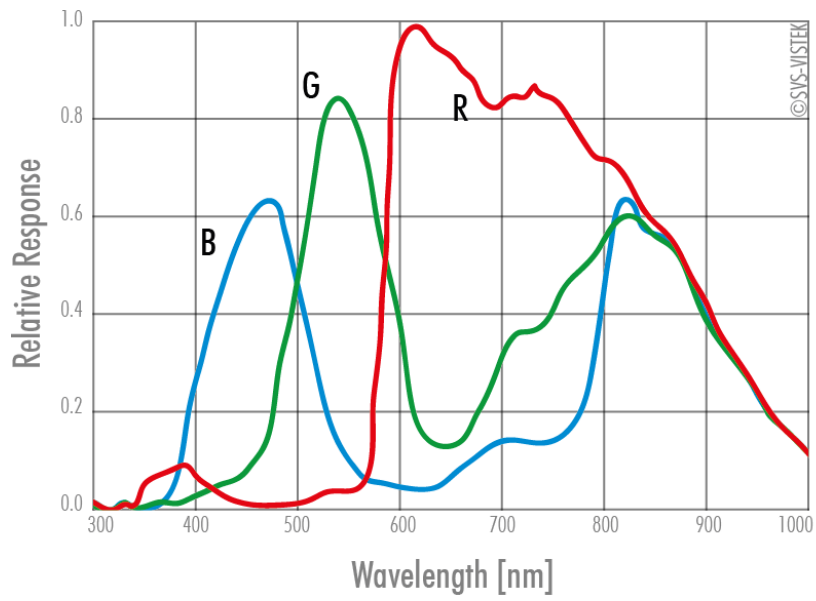

Figure 69: NOIP1SE5000A

Mono

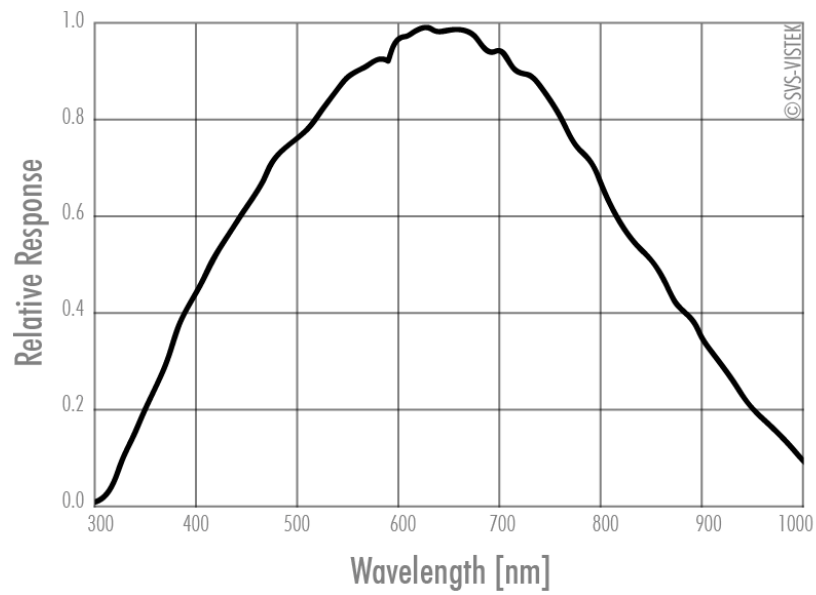

Figure 70: NOIP1SN5000A

---

## 9 Terms of warranty

Standard Products Warranty and Adjustment	Seller warrants that the article to be delivered under this order will be free from defects in material and workmanship under normal use and service for a period of 2 years from date of shipment. The liability of Seller under this warranty is limited solely to replacing or repairing or issuing credit (at the discretion of Seller) for such products that become defective during the warranty period. In order to permit Seller to properly administer this warranty, Buyer shall notify Seller promptly in writing of any claims,; provide Seller with an opportunity to inspect and test the products claimed to be defective. Such inspection may be on customer's premises or Seller may request return of such products at customer's expense. Such expense will subsequently be reimbursed to customer if the product is found to be defective and Buyer shall not return any product without prior return authorization from Seller. If a returned product is found to be out of warranty or found to be within the applicable specification, Buyer will have to pay an evaluation and handling charge, independent of possible repair and/or replacement costs. Seller will notify Buyer of the amount of said evaluation and handling charges at the time the return authorization is issued. Seller will inform Buyer of related repair and/or replacement costs and request authorization before incurring such costs. Buyer shall identify all returned material with Sellers invoice number, under which material has been received. If more than one invoice applies, material has to be clearly segregated and identified by applicable invoice numbers. Adjustment is contingent upon Sellers examination of product, disclosing that apparent defects have not been caused by misuse, abuse, improper installation of application, repair, alteration, accident or negligence in use, storage, transportation or handling. In no event shall Seller be liable to Buyer for loss of profits, loss of use, or damages of any kind based upon a claim for breach of warranty.
Development Product Warranty	Developmental products of Seller are warranted to be free from defects in materials and workmanship and to meet the applicable preliminary specification only at the time of receipt by Buyer and for no longer period of time in all other respects the warranties made above apply to development products. The aforementioned provisions do not extend the original warranty period of any article which has been repaired or replaced by Seller.
Do not break Warranty Label	If warranty label of camera is broken warranty is void. Seller makes no other warranties express or implied, and specifically, seller makes no warranty of merchantability of fitness for particular purpose.
What to do in case of Malfunction	Please contact your local distributor first.

---



---

## 10 Troubleshooting

### 10.1 FAQ

Problem	Solution
Camera does not respond to light.	<p>Check if camera is set to "Mode 0". I.e. free running with programmed exposure ctrl. When done, check with the program "Convenient Cam" if you can read back any data from the camera, such as "Mode", "type" of CCD, exposure time settings, etc..</p> <p>If "Mode 0" works properly, check the signals of the camera in the desired operation mode like "Mode 1" or "Mode 2". In these modes, check if the ExSync signal is present. Please note that a TTL signal must be fed to the trigger connector if it is not provided by the frame grabber (LVDS type). The typical signal swing must be around 5 V. Lower levels will not be detected by the camera... If you use a TTL level signal fed to the "TB 5 connector" check the quality and swing. If these signals are not present or don't have the proper quality, the camera cannot read out any frame (Mode 1 and 2). Beware of spikes on the signal.</p>
Image is present but distorted.	<p>Check the camera configuration file of your frame grabber. Check number of "front- and back porch" pixel. Wrong numbers in configuration file can cause sync problems. Check if your frame grabber can work with the data rate of the camera.</p>
Image of a color version camera looks strange or false colors appear.	<p>If the raw image looks OK, check the camera file to see if the pixels need to be shifted by either one pixel or one line. The image depends on the algorithm used. If the algorithm is starting with the wrong pixel such effects appear.</p>
Colors rendition of a color versions not as expected – especially when using halogen light.	<p>Halogen light contains strong portions of IR radiation. Use cut-off filters at around 730 nm like "Schott KG 3" to prevent IR radiation reaching the CCD.</p>
No serial communication is possible between the camera and the PC.	<p>Use "load camera DLL" and try again.</p>



Please fax this form to your local distributor. The right Fax number you can find on our homepage: <http://www.svs-vistek.com>

## 10.2 Support Request Form / Check List

Dear valued customer,

In order to help you with your camera and any interfacing problems we request that you fill in a description of your problems when you use the camera. Please fax or email this form to the dealer/distributor from which you purchased the product.

**SENDER:**

---

**FIRM:**

---

**TEL:**

---

**MAIL:**

---

Which Camera are you using?	Operating System (E.g. Win 7, XP): <hr/> Type (e.g.: sv3625MTHCPC): <hr/> <hr/> <hr/> <hr/> Serial Number: <hr/>
Which Accessories are you using?	Power Supply: <hr/> Cable: <hr/> <hr/> Lens Type and Focal Length: <hr/>
Firmware	No. of Version: <hr/> Operation Mode: <hr/> Please send a screenshot of "ConvCam" screen or log file. <hr/>
In case of EURESYS Grabber:	Brand and Type: <hr/> Driver Version: <hr/> If Patch please specify: <hr/> Camera file used: <hr/>
Short Description of Problem	(E.g. missing lines, noisy image, missing bits etc.): <hr/> <hr/> <hr/> <hr/> <hr/>

**Space for further descriptions, screenshots and log-files**

## 11 IP protection classes

There is a classification system regarding the kind of environment influences which might do harm to your product. These are called IP Protection Classes and consist of the letters „IP“ followed by two numbers.

First Digit	Second Digit	Brief description	Definition
0		Not protected	-
1		Protected against solid foreign objects, 50 mm and larger	A probing object, a ball of 50mm in diameter, must not enter or penetrate the enclosure
2		Protected against solid foreign objects, 12.5 mm and larger	A probing object, a ball of 12.5mm in diameter, must not enter or penetrate the enclosure
3		Protected against solid foreign objects, 2.5 mm and larger	A probing object, a ball of 2.5mm in diameter, must not penetrate at all
4		Protected against solid foreign objects, 1.0 mm and larger	A probing object, a ball of 1mm in diameter, must not penetrate at all
5		Protected against dust	The ingress of dust is not completely prevented. The quantity of dust that enters not impair the safety or satisfactory operation of the equipment
6		Dustproof	No ingress of dust
	0	Not protected against liquids	-
	1	Protected against water droplets	Vertically falling droplets must not have any harmful effect when the enclosure is at an angle of 15° either side of the vertical
	2	Protected against water droplets	Droplets falling vertically must not have any harmful effect with enclosure at an angle of 15° either side of the vertical
	3	Protected against spray water	Water sprayed at any angle of up to 60° either side of the vertical must not have any harmful effect
	4	Protected against water splashes	Water splashing against the enclosure from any angle must not have any harmful effect
	5	Protected against water jets	Water jets directed at the enclosure from any angle must not have any harmful effect
	6	Protected against powerful water jets	Powerful water jets directed against the enclosure from any angle must not have any harmful effect
	7	Protected against the effect of brief submersion in water	Water must not enter the equipment in amounts that can have a harmful effect if the enclosure is briefly submerged in water under standardised pressure and time conditions
	8	Protected against the effect of continuous submersion in water	Water must not enter the equipment in amounts that can have a harmful effect if the enclosure is continuously submerged in water. The conditions must be agreed between the manufacturer and the user. The conditions must, however, be more severe than code 7
	9K	Protected against water from high- pressure and steam jet cleaning	Water directed at the enclosure from any angle under high pressure must not have any harmful effect



---

## 12 Glossary of Terms

Aberration	Spherical aberration occurs when light rays enter near the edge of the lens; Chromatic aberration is caused by different refractive indexes of different wavelengths of the light. (Blue is more refractive than red)
ADC	Analogue-to-Digital Converter, also known as A/D converter
Aperture	In optics, Aperture defines a hole or an opening through which light travels. In optical system the Aperture determines the cone angle of a bundle of rays that come to a focus in the image plane. The Aperture can be limited by an iris, but it is not solely reliant on the iris. The diameter of the lens has a larger influence on the capability of the optical system.
Bayer Pattern	A Bayer filter mosaic or pattern is a color filter array (CFA) deposited onto the surface of a CCD or CMOS sensor for capturing RGB color images. The filter mosaic has a defined sequence of red, green and blue pixels such that the captured image can be transported as a monochrome image to the host (using less bandwidth); where after the RGB information is recombined in a computer algorithm.
Binning	Binning combines the charge from two (or more) pixels to achieve higher dynamics while sacrificing resolution.
Bit-Depth	Bit-depth is the number of digital bits available at the output of the Analog-to-Digital Converter (ADC) indicating the distribution of the darkest to the brightest value of a single pixel.
Camera Link	Camera Link is a multiple-pair serial communication protocol standard [1] designed for computer vision applications based on the National Semiconductor interface Channel-link. It was designed for the purpose of standardizing scientific and industrial video products including cameras, cables and frame grabbers.
CCD	Charge Coupled Device. Commonly used technology used for camera sensors used to detect & quantify light, i.e. for capturing images in an electronic manner. CCDs were first introduced in the early 70ies.
CMOS	Complementary Metal–Oxide–Semiconductor. A more recently adopted technology used for camera sensors with in-pixel amplifiers used to detect & quantify light, i.e. capturing images in an electronic manner.
CPU	Central Processing Unit of a computer. Also referred to as the processor chip.
dB	Decibel (dB) is a logarithmic unit used to express the ratio between two values of a physical quantity.
Decimation	For reducing width or height of an image, decimation can be used (CMOS sensors only). Columns or rows can be ignored. Image readout time is thereby reduced.
Defect map	Identifies the location of defect pixels unique for every sensor. A factory generated defect map is delivered and implemented with each camera.
EPROM	Erasable Programmable Read Only Memory is a type of memory chip that retains its data when its power supply is switched off.
External Trigger	Erasable Programmable Read Only Memory is a type of memory chip that retains its data when its power supply is switched off.
fixed frequency	or programmed exposure time. Frames are read out continuously.
Gain	In electronics, gain is a measure of the ability of a two-port circuit (often an amplifier) to increase the power or amplitude of a signal from the input to the output port by adding energy to the signal.

Gamma	Gamma correction is a nonlinear operation used to code and decode luminance values in video or still image systems.
GenICam	Provides a generic programming interface for all kinds of cameras and devices. Regardless what interface technology is used (GigE Vision, USB3 Vision, CoaXPress, Camera Link, etc.) or which features are implemented, the application programming interface (API) will always be the same.
GigE Vision	GigE Vision is an interface standard introduced in 2006 for high-performance industrial cameras. It provides a framework for transmitting high-speed video and related control data over Gigabit Ethernet networks.
GPU	Graphics Processing Unit of a computer.
Hirose	Cable connectors commonly used for power, triggers, I/Os and strobe lights
ISO	see Gain.
Jumbo Frames	In computer networking, jumbo frames are Ethernet frames with more than 1500 bytes of payload. Conventionally, jumbo frames can carry up to 9000 bytes of payload. Some Gigabit Ethernet switches and Gigabit Ethernet network interface cards do not support jumbo frames.
Mount	Mechanical interface/connection for attaching lenses to the camera.
Multicast	Multicast (one-to-many or many-to-many distribution) is an ethernet group communication where information is addressed to a group of destination computers simultaneously. Multicast should not be confused with physical layer point-to-multipoint communication.
PWM	Pulse width modulation. Keeping voltage at the same level while limiting current flow by switching on an off at a very high frequency.
Partial Scan	A method for reading out fewer lines from the sensor, but “skipping” lines above and below the desired area. Typically applied to CCD sensors. In most CMOS image sensors an AOI (area of interest) or ROI (region of interest) can be defined by selecting the area to be read. This leads to increased frame rate.
Pixel clock	The base clock (beat) that operates the sensor chip is. It is typically also the clock with which pixels are presented at the output node of the image sensor.
RAW	A camera RAW image file contains minimally processed data from the image sensor. It is referred as raw in its meaning. SVS-VISTEK plays out RAW only.
Read-Out-Control	Read-Out control defines a delay between exposure and image readout. It allows the user to program a delay value (time) for the readout from the sensor. It is useful for preventing CPU overload when handling very large images or managing several cameras on a limited Ethernet connection.
Shading	Shading manifests itself a decreasing brightness towards the edges of the image or a brightness variation from one side of the image to the other. Shading can be caused by non-uniform illumination, non-uniform camera sensitivity, vignetting of the lens, or even dirt and dust on glass surfaces (lens).
Shading correction	An in-camera algorithm for real time correction of shading. It typically permits user configuration. By pointing at a known uniform evenly illuminated surface it allows the microprocessor in the camera to create a correction definition, subsequently applied to the image during readout.
Shutter	Shutter is a device or technique that allows light to pass for a determined period of time, exposing photographic film or a light-sensitive electronic sensor to light in order to capture a permanent image of a scene.

<b>Strobe light</b>	<p>A bright light source with a very short light pulse. Ideal for use with industrial cameras, e.g. for “freezing” the image capture of fast moving objects. Can often be a substitute for the electronic shutter of the image sensor. Certain industrial cameras have dedicated in-camera output drivers for precisely controlling one or more strobe lights.</p>
<b>Tap</b>	<p>CCD sensors can occur divided into two, four or more regions to double/quadruple the read out time.</p>
<b>TCP/IP</b>	<p>TCP/IP provides end-to-end connectivity specifying how data should be packetized, addressed, transmitted, routed and received at the destination.</p>
<b>USB3 Vision</b>	<p>The USB3 Vision interface is based on the standard USB 3.0 interface and uses USB 3.0 ports. Components from different manufacturers will easily communicate with each other.</p>
<b>Trigger modes</b>	<p>Cameras for industrial use usually provide a set of different trigger modes with which they can be operated.</p> <p>The most common trigger modes are: (1) Programmable shutter trigger mode. Each image is captured with a pre-defined shutter time; (2) Pulse-Width Control trigger. The image capture is initiated by the leading edge of the trigger pulse and the shutter time is governed by the width of the pulse; (3) Internal trigger or Free-Running mode. The camera captures images at the fastest possible frame rate permitted by the readout time.</p>
<b>XML Files</b>	<p>Extensible Markup Language (XML) is a markup language that defines a set of rules for encoding documents in a format which is both human-readable and machine-readable</p>

---

## 13 Index of figures

FIGURE 1: TABLE OF SAFETY MESSAGES .....	5
Figure 1: Illustration of 4IO concept of switching LEDs.....	8
Figure 3: basic Illustration of driver circuit.....	15
Figure 4: Table of Camera Link pin-out / *PoCL.....	17
Figure 5: Illustration of Camera Link pin-out .....	18
Figure 6: overview of FVAL and LVAL signal timing on Camera Link .....	20
Figure 7: more detailed view of LVAL signal timing on Camera Link .....	20
Figure 8: example calculation of Camera Link timing on a exo174*CL.	20
Figure 9: Illustration of Hirose 12 Pin & pin-out (HR10A-10R-12PB).....	21
Figure 10: Illustration of C- & CS-Mount differences.....	41
Figure 11: Illustration of conventional CMOS sensor technique .....	42
Figure 12: Illustration of CMOS on chip processing.....	43
Figure 13: Illustration of CMOS four channel output .....	43
Figure 1: Rolling shutter with fast moving object details .....	45
Figure 15: motion blur .....	45
Figure 16 rolling shutter with moving objects.....	45
Figure 17: interlaced effect .....	45
Figure 1: illustration of rising amount of values/gray scales by increasing the bit format .....	48
Figure 3: Simplified illustration of a quantification graph .....	48
Figure 20: illustration of shade difference in 8 bit format.....	48
As shown in figure 21 differences in shades of gray are hardly visible on screen or in print. ....	48
Figure 22: Figure of original picture - black & white .....	49
Figure 23: Figure of quantification with 6 shades of gray (reduced colour depth).....	49
Figure 1: CCD with Bayer Pattern.....	50
Figure 25: Table of color temperatures.....	50
Figure 26: Illustration of active and effective sensor pixels .....	51
Figure 27: Table of dB and corresponding ISO .....	52
Figure 28: noise caused by increasing gain excessively .....	52
Figure 29: Figure of original image.....	53
Figure 30: Figure of image horizontally flipped .....	53
Figure 31: Figure of image vertically flipped .....	53
Figure 32: illustration of a custom LUT adding contrast to the midtones	58
Figure 33: illustration of several gamma curves comparable to a LUT ..	59
Figure 34: Illustration of AOI limitation on a CCD sensor .....	60
Figure 35: "IN0" connected to "debouncer" .....	60



Figure 4: illustration of the backside view of the camera modules. The side of the switch matrix. connections will be made with a "1" instead of a "0" .....	62
Figure 5: illustration of frontside view to the camera modules. ....	63
Figure 38: Illustration of four LEDs switched internal by the camera.....	67
Figure 39: Illustration of conventional schematic electric circuit .....	68
Figure 40: pulseloop for strobe and exposure .....	70
Figure 41: pulseloop – activating three cameras .....	70
Figure 9: Illustration of an application using the 4IO .....	73
Figure 43: illustration of three sequencer intervals .....	75
Figure 44: 25 % intensity .....	77
Figure 45: 50 % intensity .....	77
Figure 46: 75 % intensity.....	77
Figure 47: UART encoding of a data stream .....	82
Figure 48: LVDS signal – no return to zero volt.....	82
Figure 49: illustration of schmitt trigger noise suspension - high to low   low to high.....	83
Figure 50: bounces or glitches caused by a switch during 300 $\mu$ s .....	83
Figure 51: block diagram – debouncer in between the trigger source and the trigger .....	84
Figure 52: Illustration of the debouncer module .....	84
Figure 53: illustration of prescale values .....	85
Figure 54: Illustration of the prescale module.....	85
Figure 1: ECO standard & ECO Blackline with IR cut filter .....	86
Figure 56: Diagram of light transmission – IR cut filter .....	87
Figure 57: IMX174LQJ .....	91
Figure 58: IMX174LLJ .....	91
Figure 59: IMX249LQJ .....	94
Figure 60: IMX249LLJ .....	94
Figure 61: IMX250LQJR.....	97
Figure 62: IMX250LLR .....	97
Figure 63: IMX267LQR.....	100
Figure 64: IMX267LLR .....	100
Figure 65: IMX304LQR.....	103
Figure 66: IMX304LLR .....	103
Figure 67: CMV4000-3E5C1PP .....	106
Figure 68: CMV4000-3E5M1PP.....	106
Figure 69: NOIP1SE5000A.....	109
Figure 70: NOIP1SN5000A.....	109

---

## 14 Index

- 4 IO high voltage drain 67
- 4IO adds Light and Functionality 8
- Acquisition and Processing Time 46
- ADC 52
- AND 79
- AOI 60
- AR filter 86
- Assigning I/O Lines – IOMUX 60
- Auto Gain 52
- Auto Luminance 47
- Back 25, 35
- Basic Capture Modes 55
- Basic Understanding 42
- Basic Understanding of CMOS Technology 42
- Bit-Depth 48
- Boolean 79
- Bottom 25, 35
- Bounces 83
- Building blocks simplify design-in 7
- C & CS Mount 41
- Camera Features 54
- Camera Link timing 19
- Camera Link Features 8
- Camera Link Flashing LED Codes 9
- Camera Link™ 16
- CCD 60
- Clock 54
- CMOS 42, 60
- Color 50
- Connecting the camera 12
- Connectors 16
- Connectors Camera Link™ 16
- Contents of Camera Set 9
- ConvCam 113
- ConvCam5 10, 12
- Cross Section 26, 36
- Cycle duration 76
- dB 52
- debouncer 60, 84
- Debouncing 83
- Debouncing Trigger Signals 83
- Detailed Info of External Trigger Mode 56
- differential low voltage 82
- Dimensions 22
- Diode characteristic 76
- Driver Circuit Schematics 15
- duty cycle 76
- duty ratio 76
- EPROM 60
- Europe 6
- Example of an IOMUX configuration 66
- Example: 75
- Exclusive body architecture 7
- exo174\*CL, exo249\*CL 23
- exo250\*CL, exo252\*CL 27
- exo267\*CL, exo304\*CL 30
- exo4000\*CL 33
- exo5000\*CL 37
- Exposure 47, 55, 74
- Exposure Delay 72
- External Trigger (Exposure Time) 56
- FAQ 112
- Feature-Set 42
- Filter 86
- fixed frequency 55, 76
- Flip 53

- Focal Impact of Filters 87
- Frames per Second 46
- Free Running 55
- front 23, 33
- FVAL 55
- FVAL – tFvd 19
- Gain 52
- galvanical 77
- Gamma 59
- Gamma Correction 59
- Getting Started 9
- Global Shutter / Progressive Scan 45
- Glossary of Terms 117
- I/O 60
- I/O Features 60
- illumination 76
- Image Flip 53
- Image Impact of IR Cut Filter 87
- Implementation of PWM 76
- Index of figures 120
- Input / output connectors 20
- input vector to switch matrix 64
- Installation of ConvCam5 10
- interval 74
- Inverter 66
- Inverter & Set-to-1 66
- IO Assignment 83
- IP protection classes 115
- IR cut filter 50, 86
- ISO 52
- Kelvin 50
- LED 54
- LED Codes 9
- LEDs 76
- LEDs in Flash Mode 72
- Legal Information 6
- Light sources 50
- light transmission 87
- Limitation 47
- log file 113
- LookUp Table 58
- Luminance 47
- LUT 58
- LVAL 55
- LVAL – tLvd 19
- LVDS 82
- MHz 54
- Modulation frequency 76
- NAND 79
- no return to zero volt 82
- NOR 80
- of IR Cut Filter 87
- Optical Input 77
- OR 80
- output vector from switch matrix 65
- Pinout Diagram 18
- PLC/Logical Operation on Inputs 79
- Power supply 9
- Prescale 85
- pulse width modulation 67, 76
- pulseloop 76
- PWM 76
- raw 50
- readout 55
- reference of time 54
- Resolution 51
- Resolution – active & effective 51
- ROI 60
- ROI / AOI 60
- RS-232 80, 81
- RS-422 80, 82
- RXD 81
- Safety Messages 5
- schmitt trigger 83

- Sequencer 74, 76
- Serial data interfaces 80
- Setting Exposure time 47
- settings 74
- Set-to-1 66
- Shock & Vibration Resistance 6
- side Left 23, 33
- Side Right 24, 34
- Software 10
- Software Trigger 57
- Sony IMX readout technology 43
- Space for further descriptions, screenshots and log-files 114
- Specifications 88
- Spectral Impact of IR Cut Filters 87
- Strobe 60
- Strobe Control 67
- Strobe Control Example Setup 73
- Strobe Delay 72
- Strobe Duration 72
- Strobe Polarity 72
- Strobe Timing 72
- Support Request Form 113
- Support Request Form / Check List 113
- System Clock Frequency 54
- Tap Reconstruction on Camera Link 54
- temperature 54
- Temperature Sensor 54
- temperatures 50
- Terms of warranty 110
- The Debouncer module 84
- The EXO 7
- The prescale module 85
- The pulseloop module 70
- Top 24, 34
- trigger 55, 56, 57, 60, 83
- Triggered Mode (pulse width) 55
- Trigger-Edge Sensitivity 83
- Troubleshooting 112
- TXD 81
- UART 82
- USA and Canada 6
- Viewer Software 12
- Warranty 110
- WARRANTY 6, 110
- White Balance 50
- Why PWM? 76